



Seismic Internal Stability Analysis of Modular Block Reinforced Earth Retaining Wall

Anand M. Hulagabali¹ · C. H. Solanki² · G. R. Dodagoudar³ · Nayak Anitha¹

Received: 9 March 2023 / Accepted: 19 May 2023
© The Author(s), under exclusive licence to Springer Nature Switzerland AG 2023

Abstract

In India, Mechanically Stabilized Earth (MSE) walls are used extensively for flyovers in highways, slope protection works, and railway and airport projects. Recently, many failures of MSE walls have been reported and these wall failures resulted in excessive deformations or collapsed altogether. The primary causes could be insufficient or improper design and construction. In particular, a focus on stability analysis and design is needed. This study focuses on detailed static and seismic stability analysis taking into consideration the effect of various vital parameters. This study mainly aims at numerical modeling using FEM and analytical calculations as per the guidelines of AASHTO, BS8006, and China railway code TB10025. Parametric analysis has been carried out using a numerical tool GEO5, considering the effect of soil type, wall-fascia inclination, the vertical spacing between reinforcements, soil reinforcement interaction, the tensile strength of reinforcement, and surcharge magnitude. Internal stability results of Modular Block Reinforced earth retaining wall (MBW) obtained from AASHTO, BS 8006, and China Railway code TB 10025 design guidelines, show that safety factors against pullout and rupture are in close range. Backfill soil with well-graded gravel (GW), well-graded sand (SW), and poorly graded gravel (GP) has yielded good results for internal stability. The Factor of Safety (FS) against pullout failure is reduced by 15–50%, as the inclination angle increases from 50° to 90°. FS values against pullout, rupture and slip are higher for a greater number of reinforcements. FS values against pullout, rupture and slip are higher for a greater number of reinforcements. Pullout and slip resistance in the reinforcement is independent of the tensile strength of the reinforcement. For lesser magnitudes of surcharge, FS against pullout, slip, and rupture is maximum. The conclusions derived from the results of this study give a better idea of understanding the behavior of the MSE wall associated with geotechnical materials.

Keywords Modular block wall · Internal stability · Static analysis · Seismic analysis · GEO5

Introduction

Mechanically Stabilized Earth (MSE) walls are retaining walls that can restrain lateral forces by providing alternative layers of reinforcement behind the facing wall, which is compacted with soil to form an integral part to prevent deformation. The shear stress developed on reinforcement produces tension in reinforcement, which leads to

confinement to the soil and results in a decrease in soil deformation and an increase in the shear strength of the soil [1]. MSE walls help in resisting horizontal and lateral deflections. In addition, these are relatively tolerable structures for earthquakes [2]. Reinforced Earth Retaining walls are used extensively because of their cost-effectiveness and ability to withstand much larger differential settlements than conventional reinforced concrete retaining walls. These walls are composed of backfill, reinforcing elements, and facings. The most common non-metallic reinforcements are geogrids, explicitly designed to provide soil reinforcement. Some of the advantages of MSE walls with geogrid reinforcement are their durability, simplicity, and rapidity of construction [3]. Failure of an MSE wall can be attributed to poor backfill, insufficient length and strength of the reinforcement, inadequate provision of drainage, sudden drawdown of the water table, and weak foundation soil [4]. The common

✉ Anand M. Hulagabali
anandmh@nie.ac.in

¹ Department of Civil Engineering, The National Institute of Engineering, Mysuru 570008, India

² Department of Civil Engineering, Sardar Vallabhbhai National Institute of Technology, Surat, Gujrat 395007, India

³ Department of Civil Engineering, Indian Institute of Technology, Madras, Chennai 600036, India

and general methods of stability analysis are an analytical method, limit equilibrium method, and numerical method in which the limit equilibrium method considers the soil as a perfectly plastic and rigid material [5].

Since the early 1970s, many MSE walls have been constructed worldwide. Recently, however, many failures of MSE walls are being reported in most of the literature. Wall failures mentioned in the literature resulted in excessive deformations or collapsed completely. The primary causes may be insufficient or improper design and construction. In particular, a focus on stability analysis and design is needed. In MSE walls, reinforcements retained and reinforced fill soil, facing panels, and leveling pads play a vital role in stability analysis. Most of the failures are due to these parameters. Forensic engineers specializing in failures of MSE walls suggest that 1–3% failed out of 2,00,000 walls worldwide [6]. Thus, approximately 4000 walls have problems as per data presented in [6]. Proper internal and external stability analysis checks should be carried out to avoid these failures. Yang et al. [7] carried out a seismic internal stability study of GRESs under two-dimensional idealized conditions. The appropriate strength and length of reinforcement of three-dimensional GRESs are determined taking into account the pseudo-static seismic loads in this analysis. The findings are contrasted with ideal two-dimensional solutions and presented in the form of stability charts for illustrative and simple implementation purposes. Konnur et al. [8]

discussed the stability and wall movement of the new MSE wall built on a main state highway in Central Texas using the GEO5 2016 finite element (FE) analysis and slope stability limit equilibrium analysis (LE). Internal and external stability checks are being carried out from the finite element and limit equilibrium analysis with critical failure surfaces and movement of the MSE wall.

The safety factors arising from both analyzes are compared. Hulagabali et al. [9] compared the FEM results with the analytical results of the MSE wall. The finite element computer program, GEO5 FEM is used for numerical model development and the GEO5 MSE (as per AASHTO) is used for the analytical method. For horizontal and vertical deformations, the MSE walls are evaluated with the length of reinforcement. Geogrid reinforcements are tested for safety factors in terms of pullout failure and rupture and for three different backfill soils against the height of the wall. The global safety factors obtained from the FEM and AASHTO method are compared to each other for three different soils with different lengths of reinforcement. The main objective of this research paper is to study the effect of different parameters such as., fill soil, wall fascia inclination, vertical spacing between reinforcements, soil-reinforcement interaction, tensile strength of reinforcement and surcharge magnitude on the internal stability of MBW under the static and seismic loading conditions. The detailed flow chart for the present study is shown in Fig. 1.

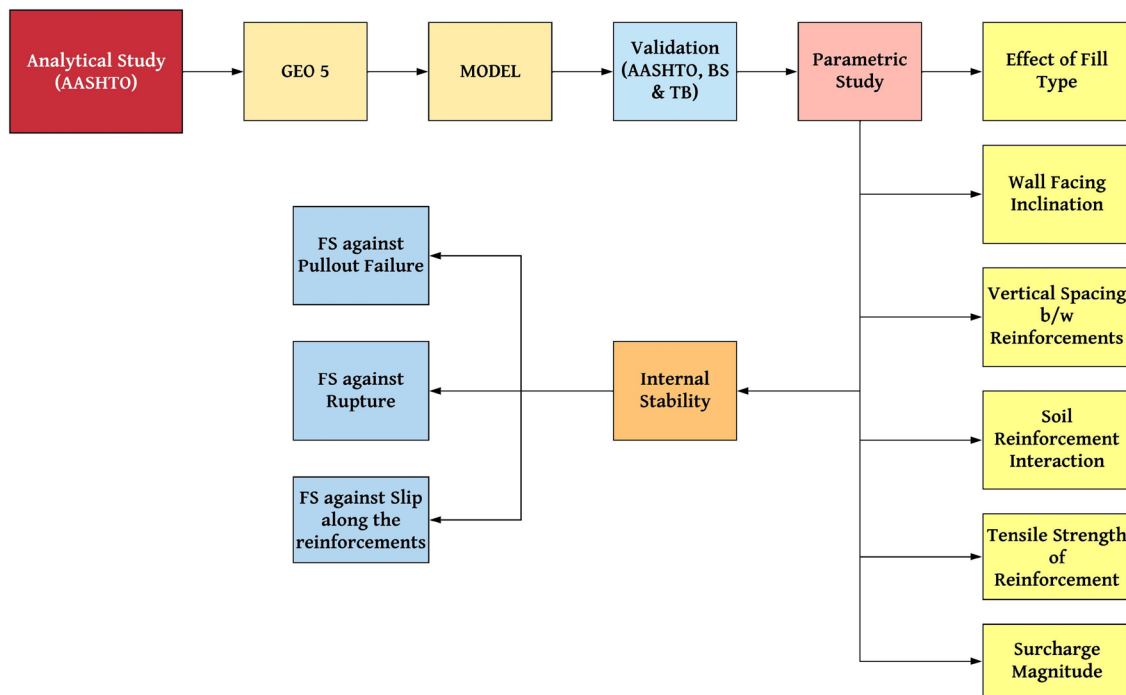

Fig. 1 Flow chart for the present study

Modeling of MBWs using GEO5

In these walls, modular blocks are used one over the other as facing panels. In this study, MBW is modeled using GEO5 software to analyze internal stability for different scenarios. Various significant parameters are considered to analyze the wall. GEO5 is a powerful tool, which allows users to analyze the wall in two and three-dimensional planes. It has also a user-friendly graphical user interface, which helps designers and researchers to solve complicated wall geometry in a short duration of time and with maximum accuracy. Active earth pressure calculations are being carried out using Coulomb's analysis. It enables the user to select appropriate wall geometry and different types of terrain to suit field conditions. Different soil types classified as per USCS are predefined in the software and user-defined soil properties can be included in the modeling. Surcharges in terms of variable, accidental, and static can be used. Wall can also be analyzed by applying external forces and moments. Pore water pressures may be introduced in the analysis by the inclusion of a water table in the backfill. Seismic analysis is carried out by adopting the coefficient of horizontal and vertical acceleration as 0.1 and 0.5. Seismic active earth pressure is based on the Mononobe-Okabe method.

Internal stability analysis is carried out using AASHTO [10] (Extensible-Straight Slip Surface), BS 8006 [11], and TB 10025-2006 Railway China code [14] recommendations. For internal stability analysis, each reinforcement in the reinforced block of the wall is checked against slip, pull-out, and rupture. Parametric analysis is carried to study the effect of various significant factors on the performance of the wall. The following flow chart explains the research design method adopted for the analytical study.

Geometry of Wall

For the analysis, a 20 m height modular block wall is considered. Details of wall geometry are given in Table 1. The foundation or leveling pad used in the modeling is 1 m in height, 5 m in width, and has an offset of 1 m. Backfill is assumed to be horizontal. Detailed components of reinforced earth wall and the geometry of the modular block wall are shown in Fig. 2a, b, respectively.

Reinforcement Details

In this analysis, reinforcements of different tensile strength are considered. In the parametric analysis, reinforcements of varying tensile strength are considered to know their effect on the wall behaviour. Reduction factors are considered to incorporate creep, durability and installation damage.

Table 1 Details of MBW components used for analysis

Parameters	Value	Unit
Wall height	20	Meters
Block height	0.25	Meters
Block width	0.5	Meters
Number of blocks	80	–
Block offset (Wall facing inclination)	0	Meters
Foundation height	1	Meters
Foundation width	5	Meters
Foundation offset	1	Meters
Backfill inclination with the horizontal plane	0	Degrees

Ultimate strength (T_{ult}) of reinforcement is reduced by applying reduction factors to obtain long-term design strength (T_{LTDS}) of reinforcement. Details of reinforcement are given in Table 2.

Details of Backfill and Reinforced Soils

Backfill and reinforced soil properties are selected based on the recommendations of AASHTO, FHWA and NCMA [13]. Six types of soils are considered which possess good angles of internal friction and unit weight as shown in Table 3. In the analysis of the wall, soil selected for both backfill and reinforced block are the same. MSE wall require high-quality backfill for durability, good drainage, compactability and high shear transfer from the reinforcement. Cohesionless materials are used and soils with high clay content are eliminated. FHWA (1998) recommends the gradation limits for backfill in the reinforcement zone as shown in Table 4 and Table 5. Also, NCMA, 2012 recommends the selection of backfill material as shown in Table 6. Particle size distribution curves for the considered backfills are shown in Fig. 3.

Modular Block Facing

Facings of MSE walls are covered with modular blocks with plain concrete of unit weight of 23 kN/m³. 80 blocks are used which are arranged vertically one over the other. Vertical thickness of each block is 250 mm and the width is 500 mm. In the initial analysis, the offset of the block is kept zero. Later, to know the effect of block offset on wall performance, it is varied as 0.05, 0.10, 0.15 and 0.20 m. For every change in block offset there is a change in wall-facing inclination. Effect of offset and wall fascia inclination on the internal stability of the wall is discussed in detail in Sect. "Effect of the Wall-Facing Inclination".

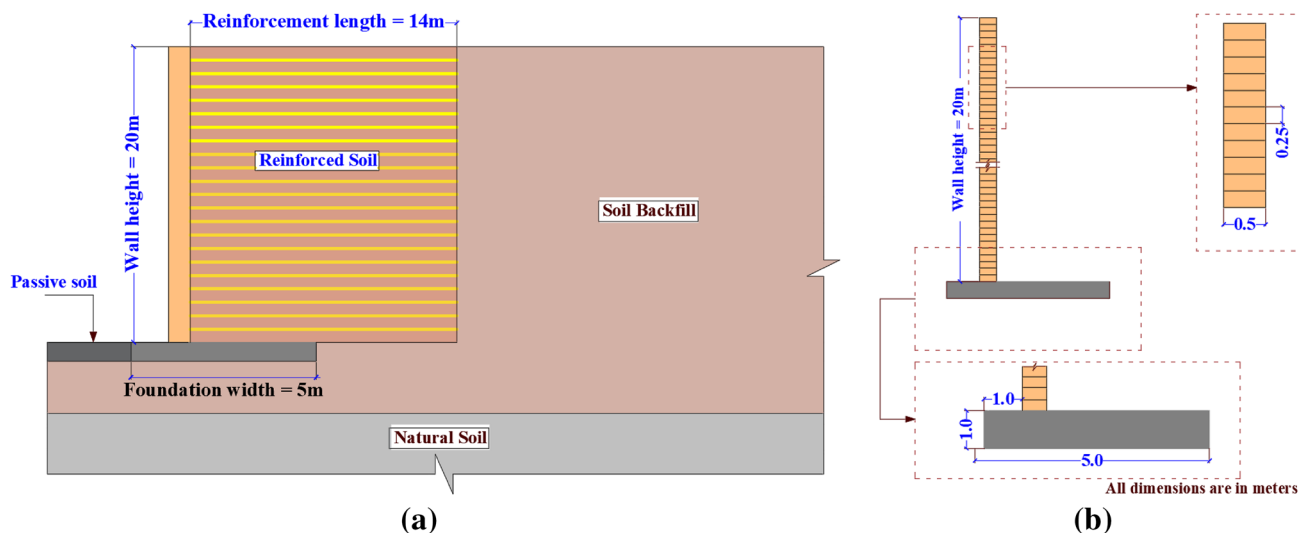

Fig. 2 a Components of Reinforced Earth Wall. b Geometry of MBW used for analysis

Table 2 Description of different reinforcements used for analysis

Type of Reinforcement	T_{ult} (kN/m)	RF_{CR}	RF_D	RF_{ID}	FS_{UNC}	T_{LTDS} (kN/m)
Extensible	63.8	1.72	1.1	1.25	1.5	18
	92.1	1.72	1.1	1.25	1.5	26
	138.1	1.72	1.1	1.25	1.5	39
	184.1	1.72	1.1	1.25	1.5	52

Table 3 Properties of backfill soils used in the analysis

Soil Properties	Units	Soil Types as per Unified Soil Classification System (USCS)					
		SM ^a	SP ^b	SW ^c	GM ^d	GP ^e	GW ^f
Unit weight (γ)	kN/m ³	18	18	20	19	20	21
Angle of internal friction (ϕ)	Degrees	29	33	36	34	38	40
Cohesion (C)	kN/m ²	5	5	Zero	4	Zero	Zero
Poisson's ratio (μ)	–	0.3	0.28	0.28	0.30	0.20	0.20
Deformation modulus (E_{def})	MPa	10	25	37	70	145	320
Design bearing capacity	kPa	B < 0.5 m					
		175	160	195	250	260	325
		B < 1 m					
		225	225	325	300	420	520
B < 3 m							
300	390	520	400	550	650		

^aSM Silty Sand

^bSP Poorly Graded Sand

^cSW Well Graded Sand

^dGM Silty Gravel

^eGP Poorly Graded Gravel

^fGW Well Graded Gravel

Table 4 Gradation requirements (FHWA 1998) [12]

US Sieve size	Percent passing (%)
4 inches (102 mm)	100
No. 40 (0.425 mm)	0–60
No. 200 (0.075 mm)	0–15

Static and Seismic Analyses

Wall analysis is carried out for both static and seismic analysis. Wall may be built in earthquake-prone areas, where the magnitude of the earthquake may be very high. To incorporate the effect of least to high magnitude seismic effects, pseudo-dynamic analysis with varying horizontal and vertical coefficient of earthquakes are considered for analysis. Seismic

Table 5 Other backfill properties requirements

Property	Requirement
Angle of friction (AASHTO T 236)	> 34°
Plasticity Index, PI (AASHTO T 90)	PI < 6%
Soundness (AASHTO T 104)	The material shall be substantially free of shale or other soft, poor durability particles. The material shall have a magnesium sulphate soundness loss of less than 30% after four cycles

Table 6 Selection of backfill material as per NCMA recommendations (NCMA, 2012)

Unified Soil Classification	Effective angle of shearing resistance (°)	Shear strength when compacted and saturated	Frost-heave potential	Comments
GW, GP	37–42	Excellent to good	Low	Recommended for backfill
GM, SW, SP	33–40	Excellent to good	Moderate	Recommended for backfill
GC, SM, SC, ML, CL	25–32	Good to fair	Moderate to High	Recommended for backfill with additional criteria
MH, CH, OH, OL	N/A	Poor	High	Generally, not Recommended for backfill
Pt	N/A	Poor	High	Not Recommended for backfill

Fig. 3 Particle size distribution curves of backfill soils considered in the analysis

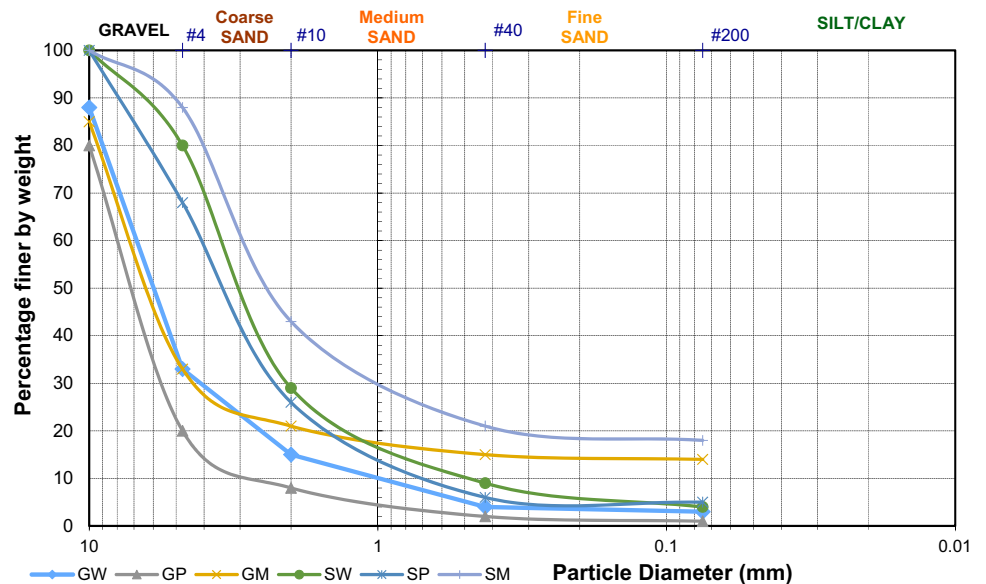

coefficients considered for the analysis are 0.1 to 0.5. Seismic coefficients may be defined for the horizontal and/or vertical directions. The seismic coefficients are dimensionless coefficients that represent the (maximum) earthquake acceleration as a fraction of the acceleration due to gravity. If seismic coefficients are defined, a seismic force will be applied to the reinforced block as follows:

$$\text{Seismic force} = \text{Seismic coefficient} \times \text{block weight} = \text{seismic coefficient} \times \text{area of block} \times \text{unit weight of the block.}$$

The horizontal seismic coefficient is always positive. The vertical seismic coefficient may be either positive or negative. A positive vertical seismic coefficient represents a vertical seismic force directed downwards. A negative vertical seismic coefficient represents a vertical seismic force directed upwards. The effect of a vertical seismic force is less obvious. A vertical seismic coefficient may either decrease or increase the safety factor since the vertical seismic force affects the normal stress, and hence the shear strength.

Internal Stability Analyses as per AASHTO, BS 8006 and TB 10025

MBW is analyzed for internal stability using three significant recommendations given by AASHTO, BS 8006 and China Railway code TB 10025. This study is carried out for the purpose of validation, such that further parametric analysis can be carried out using any of the above methods. Location of failure surface in the above recommendations varies according to the assumptions made. In AASHTO guidelines, failure surface pattern for extensible (Geotextile or Geogrid) and inextensible (Steel) reinforcements are different. For extensible reinforcement assumed failure pattern is shown in Fig. 4a BS 8006, which considers a two-part wedge analysis for internal stability calculations as shown in Fig. 4b. Failure wedge recommended by China railway code TB 10025 is shown in Fig. 4c. In AASHTO guidelines, the failure surface is inclined at an angle $\psi = 45^\circ + \phi/2$ with the horizontal. Failure surface divides the reinforced block into active and passive zones. AASHTO method is also called as tie-back wedge methods, where the failure surface linearly increases from the bottom to the top of the wall. surcharge with magnitude 100 kPa is considered. AASHTO guidelines work on the principle of straight slip surface, whereas, BS 8006 and TB 10025 works on coherent method and its modified form. FS against pullout failure as shown in Fig. 5 and rupture as shown in Fig. 6 are calculated for both static and seismic analysis.

FS Against Pullout Failure

In the middle portion of the wall (from height 5 m to 15 m), percentage difference in pullout safety factors is around 5

to 10%. For, this analysis, the vertical spacing of reinforcements of 0.05H (20 reinforcement layers) is considered. It is observed from Fig. 5, that pullout resistance in the top reinforcement layers is less compared to the bottom layers.

Results obtained for the three guidelines are in good agreement except for slight changes for the middle portion of the wall, as the failure pattern assumed are different. Maxi-

imum safety factor for pullout resistance for static analysis is observed to be 138. For seismic analysis, the coefficients of the earthquake are considered as 0.1 and 0.5. It is observed that FS obtained with a seismic coefficient 0.1 are almost the same as static analysis. Whereas pullout safety factors w.r.t seismic coefficient of 0.5 are less. From Fig. 5b, it is seen that safety factors for pullout failure with a seismic coefficient of 0.1 are 30.30, 31.92 and 26.42 for AASHTO, BS 8006 and TB 10025 respectively for the 10th layer. For a seismic coefficient of 0.5, safety factors obtained are 12.23, 12.88 and 10.66 for AASHTO, BS 8006 and TB 10025, respectively.

FS Against Rupture

It is understood that, from AASHTO guidelines, the failure wedge pattern varies linearly from the bottom to the top of the wall. Because of this assumed pattern, FS for rupture is also varying linearly, except for some minor variations in the topmost and bottom layer as shown in Fig. 6.

This variation may be due to lesser and very high overburden pressure at the top and bottom layer respectively. Also, it is observed that safety factors from the three guidelines for rupture are in good agreement except in the top portion of the wall. It may be due to assumed failure patterns in these recommendations. Ultimate tensile strength of reinforcement is taken as 184.1 kN/m. Wall with more reinforcements gives better safety factors against rupture compared to lesser reinforcements. From the Fig. 5, it is observed that the tensile safety factor as per BS 8006 and TB 10025 codes, has taken slight deviation from the AASHTO guidelines at the top 25% of the wall. It is also observed that there is a sudden increase in FS against rupture at the bottom layer as shown in Fig. 6. This deviation is due to the restraint at the bottom layer.

Observations and Discussions

Results obtained from the most widely used design guidelines for the internal stability of MBW show that safety factors against pullout and rupture are in close range.

Fig. 4 Failure surface location for internal stability as per **a** AASHTO **b** BS 8006 and **c** China Railway code TB 10025

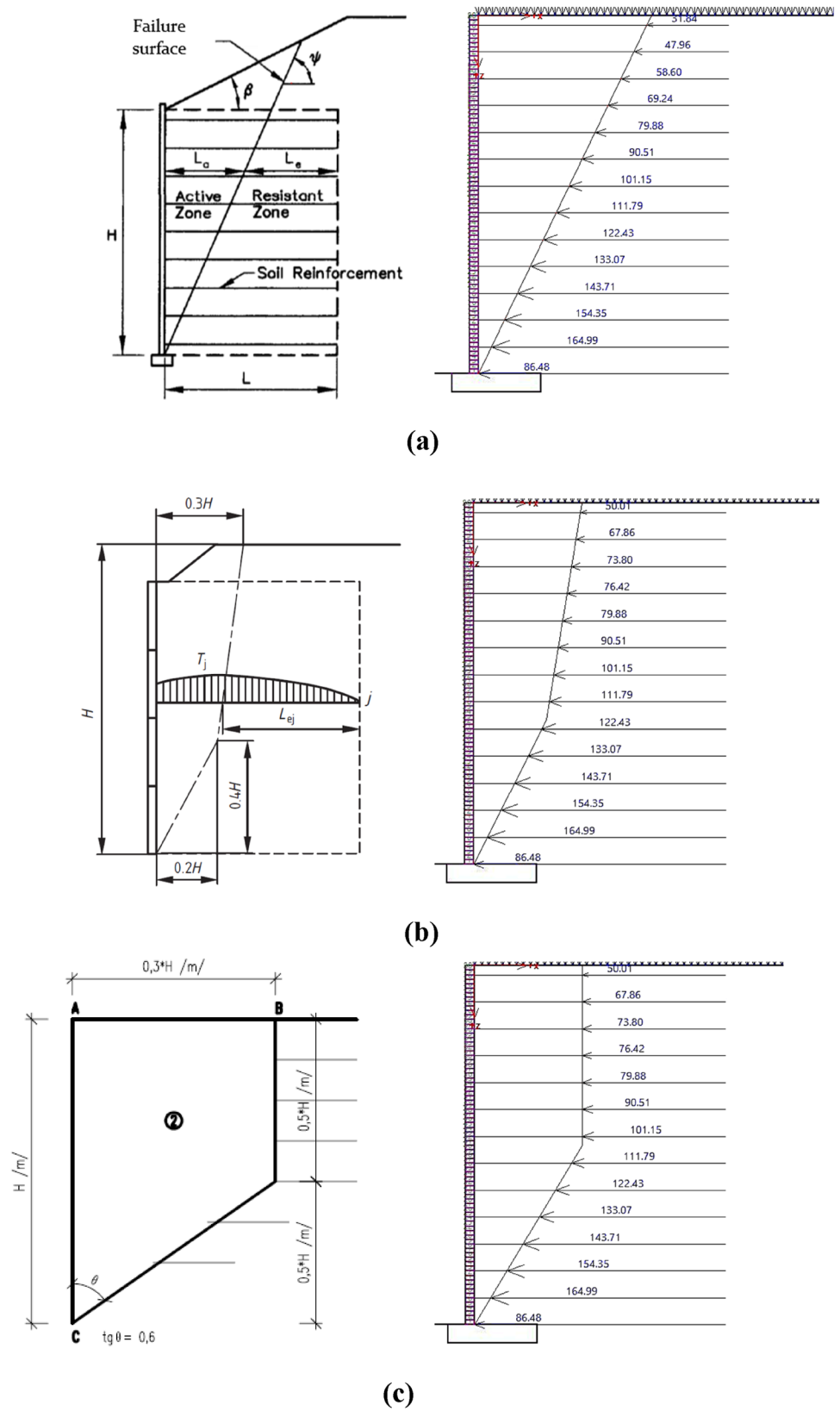

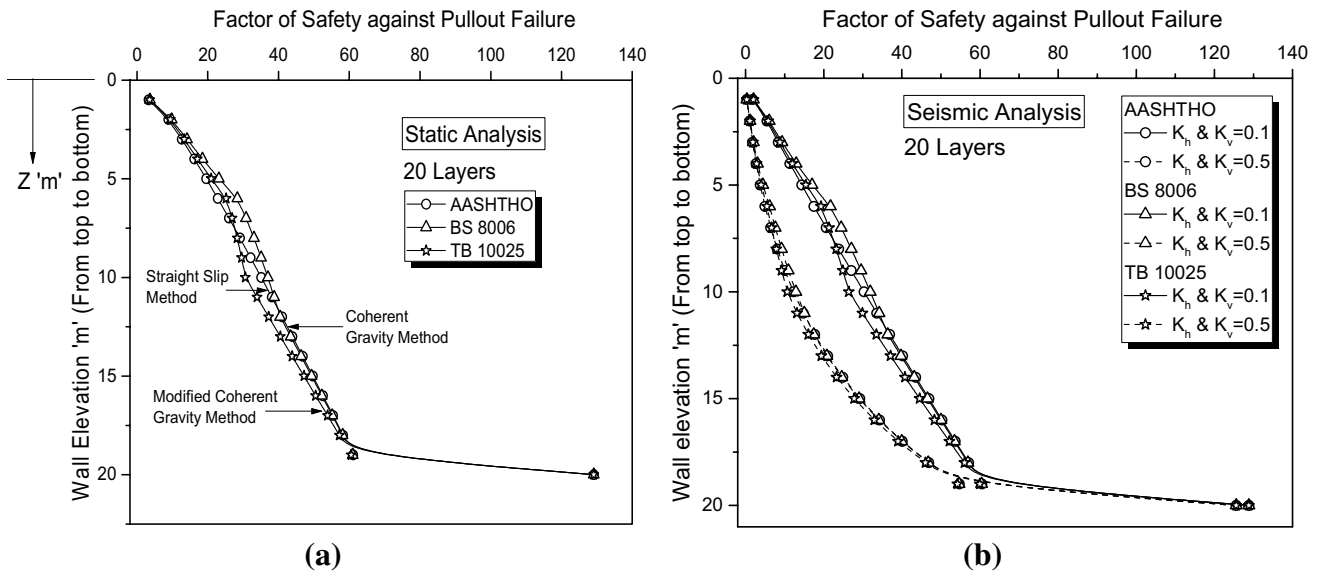

Fig. 5 FS against pullout failure as per AASHTO, BS 8006 and TB 10025 a Static Analysis b Seismic Analysis

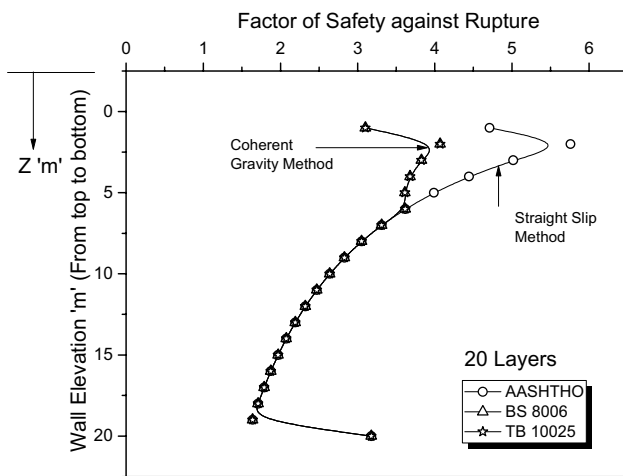

Fig. 6 FS against rupture as per AASHTO, BS 8006 and TB 10025

Pullout resistance decreases gradually from the top to the bottom of the wall. It is maximum in the bottom layers, as overburden pressure in the bottom layers will be maximum. Whereas rupture is minimum in the bottom layers of the wall and more in the top layers. For the higher reinforcements in the reinforced soil zone, safety factors for tensile and pullout failure obtained are more. This is due to different assumptions made only in internal stability analysis. In this section, a validation study has been carried out, which helps to carry out the parametric study further.

Parametric Studies on Internal Stability of MBWs

After a successful validation study, key parameters for the design of modular block walls are identified and detailed parametric analysis is carried out. Parameters considered to study the internal stability analysis of a wall under static and seismic conditions are filled soil types, wall-facing inclination, vertical spacing of reinforcements, soil-reinforcement interaction, tensile strength of reinforcement and surcharge on the backfill of the wall.

Effect of Fill Soil Type

Internal stability of the wall is carried out by considering the length of the reinforcements as 14 m and vertical spacing between reinforcements as 2.5 m. Backfill is assumed to be horizontal. As discussed earlier, internal stability can be carried out using many popular guidelines such as AASHTO, BS 8006, TB 10025 China Code, and FHWA. In this analysis, AASHTO recommendation are considered for internal stability checks. FS against pullout and slip for different backfill soils are presented in Fig. 7. FS against rupture resistance is presented in Fig. 8.

FS against Pullout Failure

Reinforcements are numbered from bottom to top of the wall in increasing order (1–8) as is seen in Fig. 7. Pull-out resistance is maximum in reinforcement number 1, as total overburden stress is maximum at the bottom layer, whereas at the top layer (reinforcement #8) pull-out resistance is very less

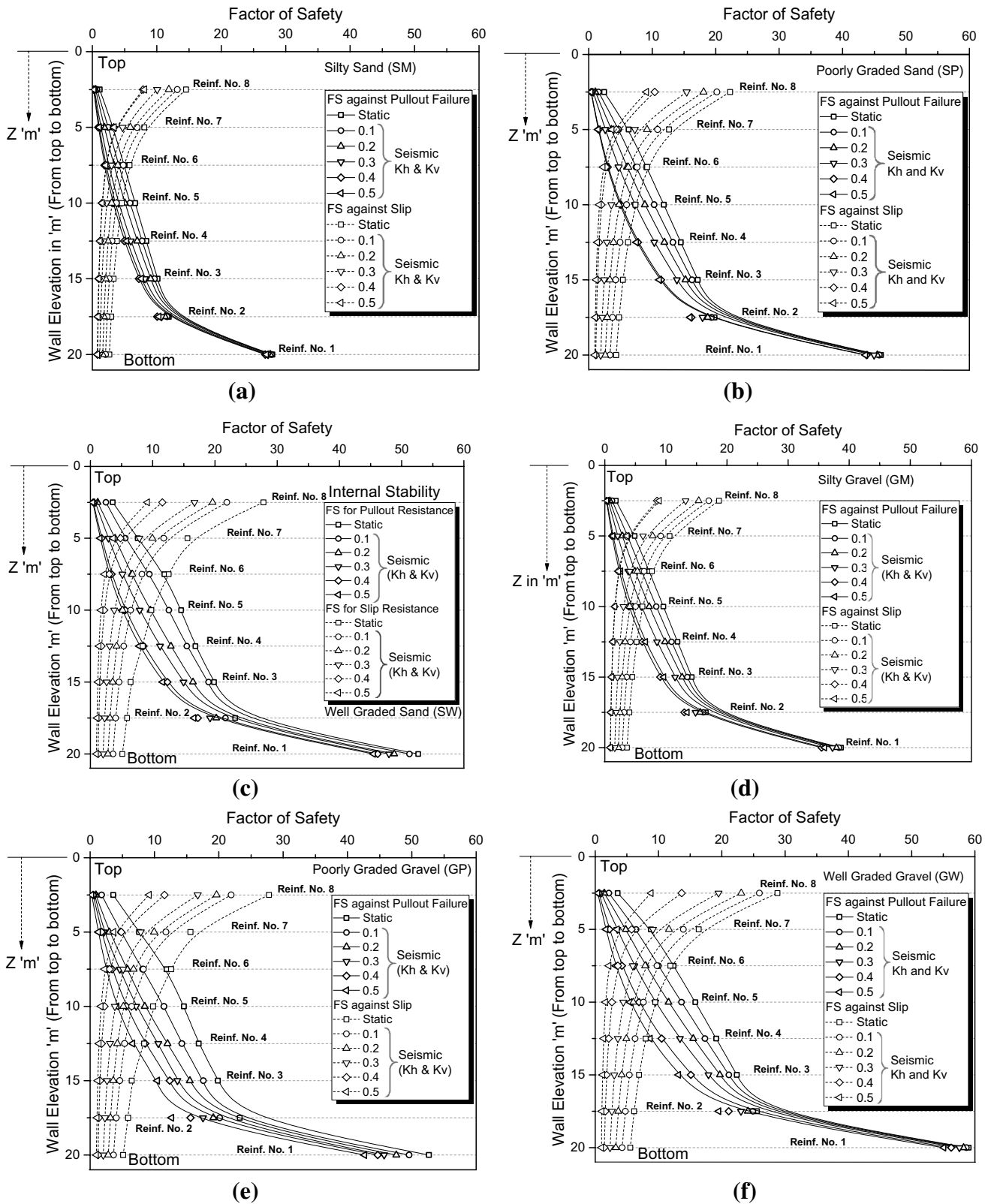

Fig. 7 FS against pullout failure and slip **a** Silty Sand (SM) **b** Poorly Graded Sand (SP) **c** Well Graded Sand **d** Silty Gravel (GM) **e** Poorly Graded Gravel (GP) **f** Well Graded Gravel (GW)

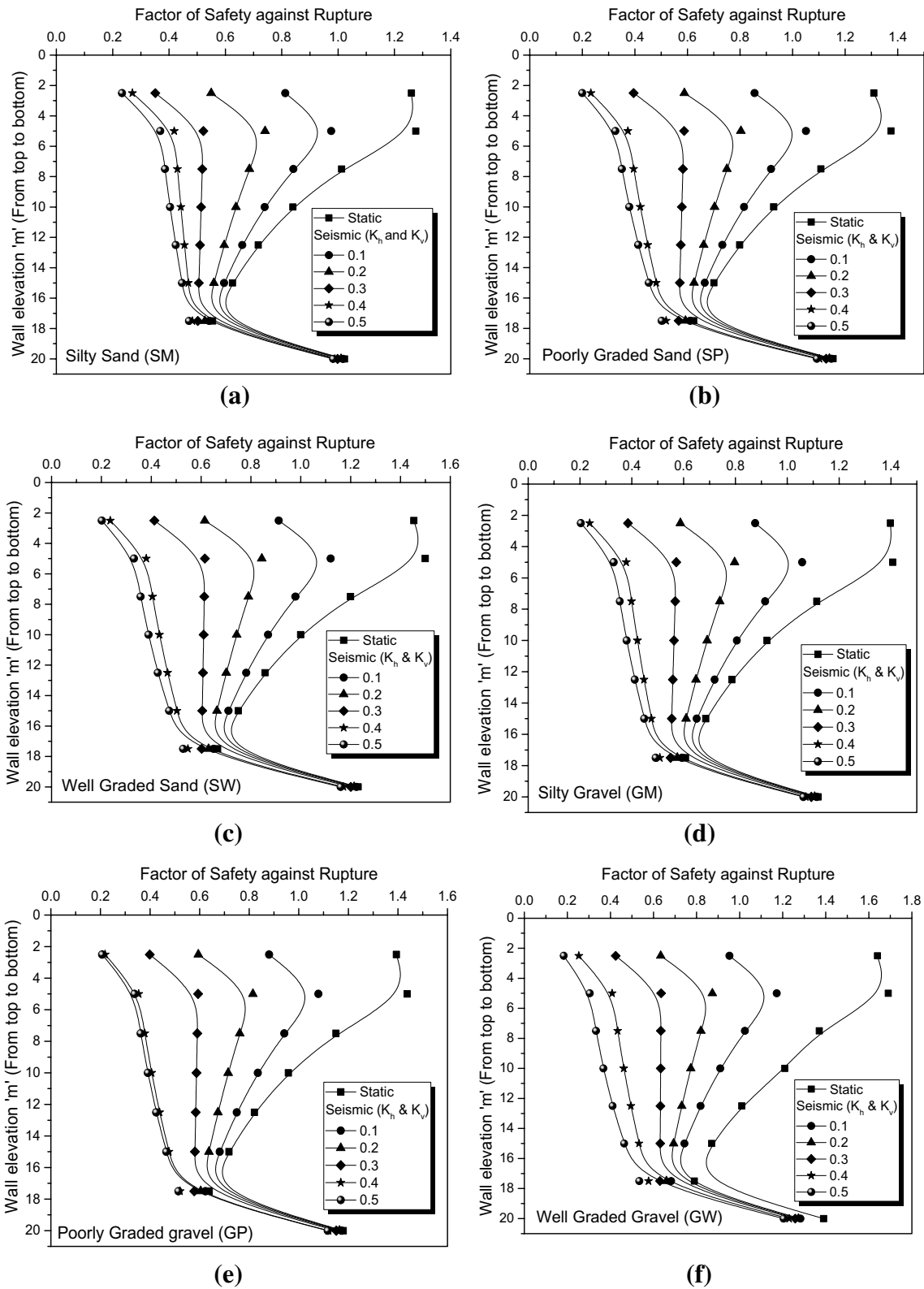

Fig. 8 FS against rupture **a** Silty Sand (SM) **b** Poorly Graded Sand (SP) **c** Well Graded Sand **d** Silty Gravel (GM) **e** Poorly Graded Gravel (GP) **f** Well Graded Gravel (GW)

because of lesser overburden pressure. The maximum safety factor against pullout failure is near 29 in the bottom reinforcement for static conditions. Even in this case, the earthquakes have a significant effect on the pullout resistance. In reinforcement number #1, FS against pull-out resistance is near 27 for an earthquake efficiency of 0.5. FS against pull-out failure has gradually increased from the top to the bottom of the wall. FS against slip gradually increased from the bottom to the top of the wall. In the middle reinforcements, the difference between static and seismic pullout safety factor is higher compared with end reinforcements as shown in Fig. 7e, f. FS safety for pullout failure depends on both reinforcement and backfill properties. Pullout safety factor in the MSE wall is mobilized due to the interaction between the reinforcement and the backfill soil. It is the combination of frictional and passive resistance. Pullout resistance is directly related to interface shear strength parameters (Interface friction angle and cohesion).

FS against Slip Along the Reinforcements Slip resistance observed from Fig. 7a–f, is maximum near the top of the wall and less in the bottom layers of the wall. Slip resistance depends upon the slip failure surface assumed as per Tie back wedge method used by AASHTO. The portion of reinforcements in the active zone is responsible for slip resistance as shown in Fig. 4a. Failure surface has a triangular distribution that increases from the bottom to the top of the wall. As it is seen from Fig. 4a, the percentage of reinforcements involved in the active zone for slip resistance is maximum in the upper portion of the wall and less in the bottom portion of the wall. From Fig. 7a–f, it is observed that the maximum safety factor against slip is nearly 30, for reinforcement #8 (top layer) with well-graded gravel as backfill. In reinforcement #8, the least safety factor against slip is nearly 10, for a seismic coefficient of 0.5, for all types of backfill. Slip resistance decreases towards the bottom of the wall with safety factor values ranging from 1 to 5, at reinforcement #1, for both static and seismic conditions, with all six types of backfill soil.

FS against Rupture

Ultimate tensile strength of the reinforcement is taken as 184.1 kN/m. FS against rupture mainly depends upon the tensile strength of reinforcements. In this study, the greater interaction between backfill and reinforcement, the higher is the safety factor for rupture. As, the angle of shearing resistance of soil increases, the safety factor for rupture increases. For well-graded gravel as backfill, the highest safety factor against rupture is recorded at almost 1.7. Denser reinforcements will have better resistance against rupture, which is discussed in later sections. Resistance to rupture should be greater than 1.5. In static loading conditions, more safety

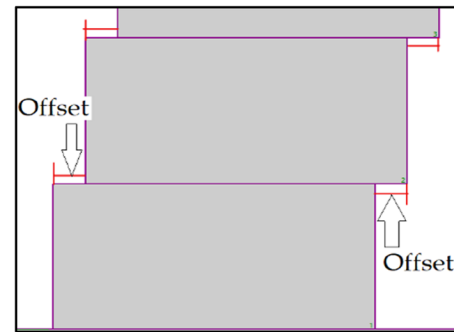

Fig. 9 Definition of offset used in the analysis

Table 7 Offsets and inclination angles used for analysis

Offset used (m)	0	0.05	0.10	0.15	0.20
Angle of inclination (β , °)	90	80	70	60	50

factors are achieved. But safety factors against rupture decreases for seismic conditions. Especially for a seismic coefficient of 0.4 and 0.5, a safety factor is less than 0.5 for all backfill types as seen from Fig. 8a–f FS against Rupture is minimum at the bottom reinforcement layers of the wall. Rupture capacity of reinforcement depends upon the failure surface assumed during the analysis. It also depends upon the ultimate and long-term design tensile strength of the reinforcement. As it is seen from Fig. 8a–f, factor of safety against rupture is not much affected by the backfill material, as it is mainly dependent upon the tensile strength of the reinforcement.

Effect of the Wall-Facing Inclination

Wall-facing inclination is achieved by changing the offset between two consecutive modular blocks. ‘Offset’ is the distance between the outer edge of the two consecutive blocks as explained in Fig. 9. Details of offset used in the analysis are shown in Table 7 and Fig. 10. Wall fascia inclination should be given based on the site profile. Backfill soil is considered as Well Graded Gravel (GW). Tensile strength of reinforcement, length and spacing are 184.1 kN/m, 0.7H and 0.125H, respectively. Coefficient of interaction is 0.85. Surcharge of 100 kPa is applied on the horizontal backfill.

FS Against Pullout Failure

Figure 11a, b, present FS results obtained for pullout failure resistance obtained for seismic coefficients of 0.5. It is observed from the results, FS against pullout failure is maximum at the bottom layers. It is understood that pullout resistance is directly proportional to effective vertical

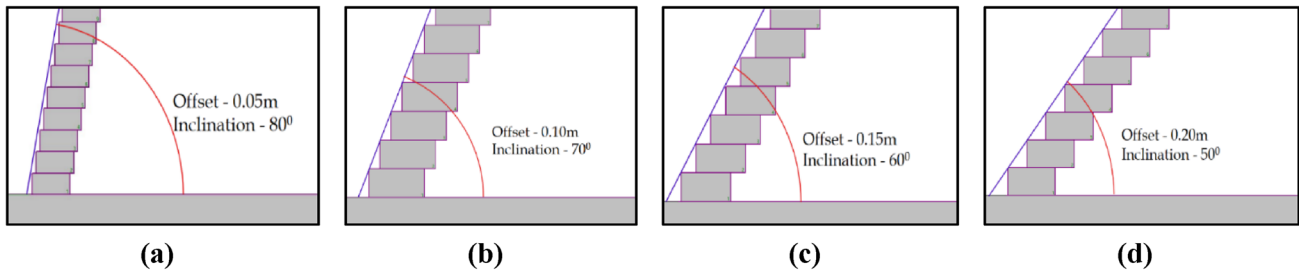

Fig. 10 Wall facing with inclination angle a 80° b 70° c 60° and d 50°

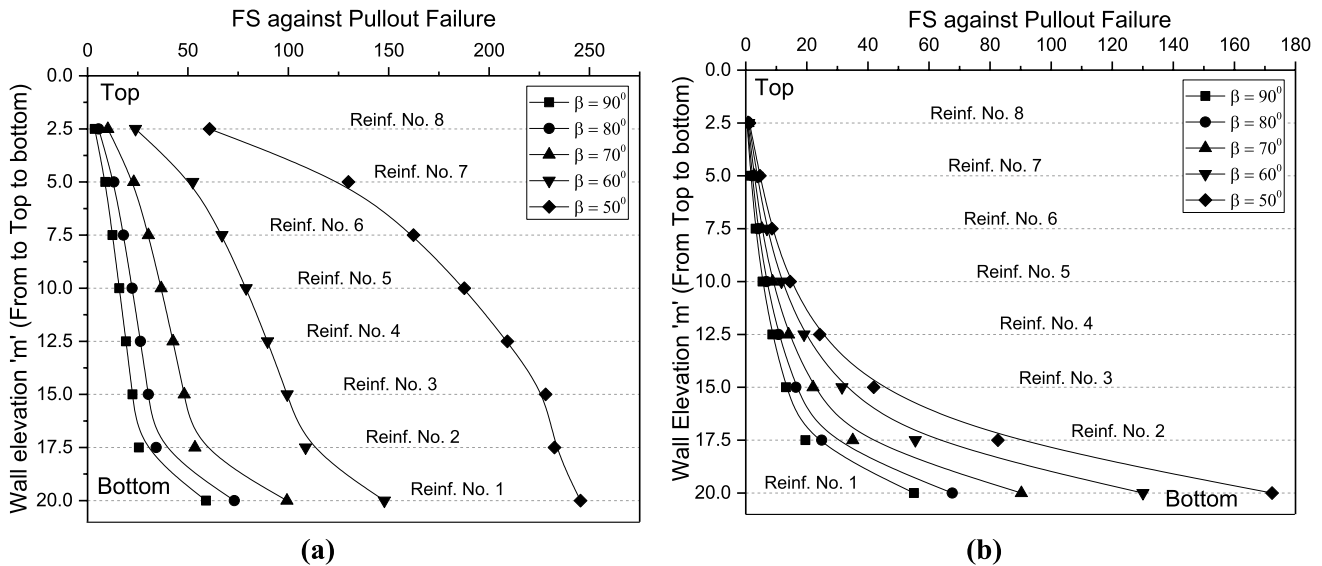

Fig. 11 FS against pullout failure with different wall-facing angles a Static Analysis b Seismic Analysis (k_h & $k_v=0.5$)

overburden pressure. Maximum FS against pullout failure is observed to be 250 at reinforcement #1 with wall inclination, $\beta = 50^\circ$ and static loading condition. As the facing angle decreases FS against pullout failure increases. Very minimum resistance for pullout capacity is observed in the top layers of the wall. When the inclination of wall facing start reduces from 90° , percentage distribution of reinforcements in the passive zone will be maximum and minimum in the active zone. Hence, it is seen from the results that, lesser the wall-facing angle, greater is the pullout resistance. For a seismic coefficient of 0.5, the maximum FS against pullout failure is 170. As observed from Fig. 11a, b, FS for pullout failure is maximum for wall with $\beta = 50^\circ$, and minimum for wall with vertical face ($\beta = 90^\circ$).

FS Against Rupture As shown in Fig. 12, for a wall with a facing angle $\beta = 50^\circ$, FS against rupture is maximum at the top layers and gradually decreases in the bottom layers. Maximum FS against rupture was observed to be 15 in

reinforcement #7 at the top portion of the wall with a facing angle of 50° and static loading conditions.

Slight variation in the FS against rupture among eight reinforcement layers is observed for walls with facing angle of 60° and 50° . It is also observed that there is an almost constant distribution of rupture among all eight layers for wall fascia angles of 90° , 80° and 70° for both static and seismic loads. At the bottom portion of the wall, the percentage of reinforcements in the passive zone is maximum. Therefore, the safety factor against rupture is maximum at the bottom layers. Throughout the height of the wall, FS against rupture is almost constant for wall fascia inclination of 90° , 80° and 70° . For $\beta = 50^\circ$ and 60° , there is a decrease in FS against rupture.

FS against Slip Along the Reinforcements As it is seen from Fig. 13, when the wall face is gradually inclined, the slip resistance of reinforcements reduces by 5 to 6%. For $\beta = 50^\circ$, slip resistance is very less compared with $\beta = 90^\circ$. For static loading conditions, maximum slip resistance is

observed to be 28, in reinforcement #8 as seen in Fig. 13a and Fig. 13b for wall with $\beta=90^\circ$. Whereas minimum FS for slip is observed for $\beta=50^\circ$ at reinforcement #1 (Bottom layer). From Fig. 12b, it is seen that FS for slip is 9 at rein-

forcement #8, for a seismic coefficient of 0.5 and minimum FS observed at reinforcement #1, with a value less than 1.

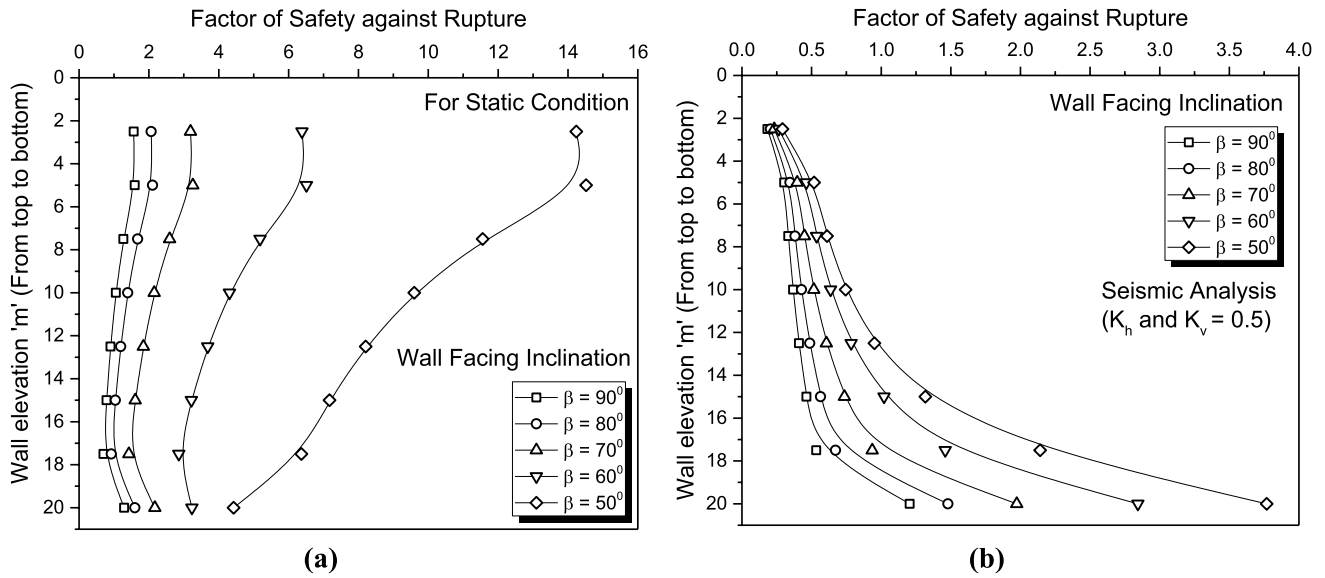

Fig. 12 FS against rupture with different wall-facing angles a Static Analysis b Seismic Analysis (k_h & $k_v=0.5$)

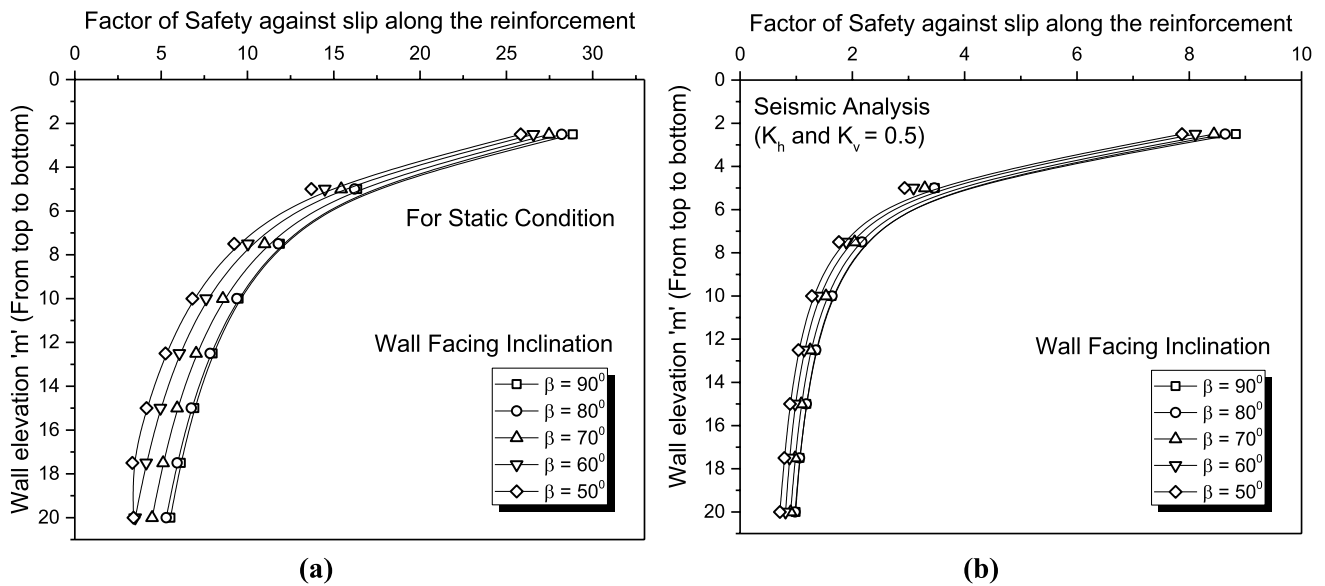

Fig. 13 FS against slip with different wall facing angles a Static Analysis b Seismic Analysis (k_h & $k_v=0.5$)

Table 8 Details of vertical spacing of reinforcements used in the analysis

Vertical spacing	0.125 H=2.5 m	0.1 H=2 m	0.075 H=1.5 m	0.05 H=1 m
No. of Reinforcements	8	10	14	20

Effect of Reinforcement Spacing

Reinforcements are used with four different vertical spacing (S_v). In the total height of 20 m wall, the vertical spacing of reinforcements and the number of reinforcements are considered as shown in Table 8. Modular block properties are kept the same as in the previous analysis. Backfill soil is considered as well-graded gravel (GW). Ultimate tensile strength of reinforcement and length are 184.1 kN/m and 0.7H, respectively. Coefficient of interaction is 0.85. Surcharge of 100 kPa is applied on the horizontal backfill.

Internal stability analysis is carried out to determine the FS against pullout failure, rupture and slip. Failure slip surface is considered as per tie back wedge method. Static and

seismic effects are compared for the pullout failure of reinforcements. Figure 14a, shows the results of the safety factor for pullout failure with static and seismic analysis with k_h & $k_v = 0.1$. Figure 14b, shows the comparison of FS against pullout failure obtained from seismic coefficients of 0.2 and 0.3. Similarly, Fig. 14c, shows the pullout safety factors obtained from seismic coefficients of 0.4 and 0.5.

FS Against Pullout Failure

From Fig. 14a, the maximum FS for pullout failure obtained are 150 with reinforcement spacing (S_v) of 0.05H, 100 for $S_v = 0.075H$, 70 for $S_v = 0.1H$ and 60 for $S_v = 0.125H$. From the results of Fig. 14a, it is clear that there is a 15 to 20%

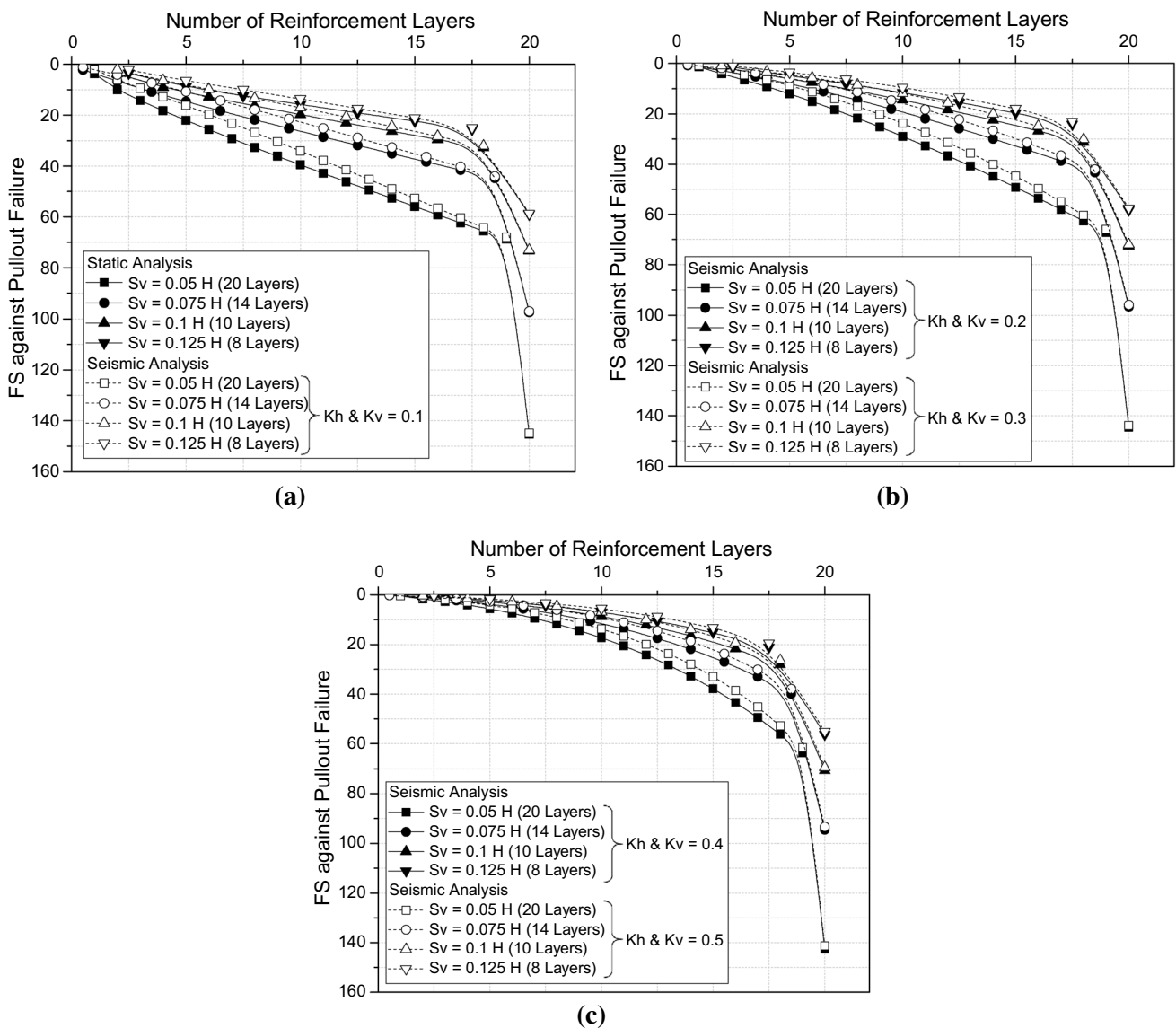

Fig. 14 Pullout resistance for wall with varying S_v of reinforcements **a** Static and Seismic, k_h & $k_v = 0.1$ **b** Seismic, k_h & $k_v = 0.2$ and 0.3 **c** Seismic, k_h & $k_v = 0.4$ and 0.5

decrease in the FS against pullout failure because of a seismic coefficient of 0.1. From Fig. 14b, due to the seismic coefficients of 0.2 and 0.3, there is a difference in the result of pullout resistance of 12 to 13%. Maximum pullout resistance obtained from seismic coefficients of 0.4 and 0.5 are less compared with static and lesser seismic coefficients. FS against Pullout failure obtained are 15% lesser for the seismic coefficient of 0.5 when compared with a seismic coefficient of 0.4.

FS Against Rupture From Fig. 15, maximum FS against rupture observed is 1.6 at reinforcement #7, with a tensile strength of reinforcement 184.1 kN/m. There is a difference of 25% in FS against rupture in between different tensile strength of reinforcement. FS against Rupture is maximum at the top portion of the wall. From Fig. 15a–d, it is seen that resistance for rupture is more with the increase in vertical

spacing (S_v) of reinforcements. For seismic conditions, there was very little change in the values compared with static conditions. At the bottom layer, the deviation is more in the case of reinforcement with ultimate tensile strength 184.1 kN/m as seen in Fig. 15c. FS against rupture is more than 8 for ultimate tensile strength 184.1 kN/m and reinforcement spacing, $S_v = 0.05H$.

FS against Slip Along the Reinforcements From Fig. 16, maximum slip resistance for reinforcement with vertical spacing, $S_v = 0.125H$, $0.1H$, $0.075H$ and $0.05H$ are 34, 43, 55 and 72, respectively. Slip resistance is maximum at the bottom part of the wall as the passive zone to resist slip will be more. Slip resistance values for reinforcements of different tensile strength remained the same as shown in Fig. 16.

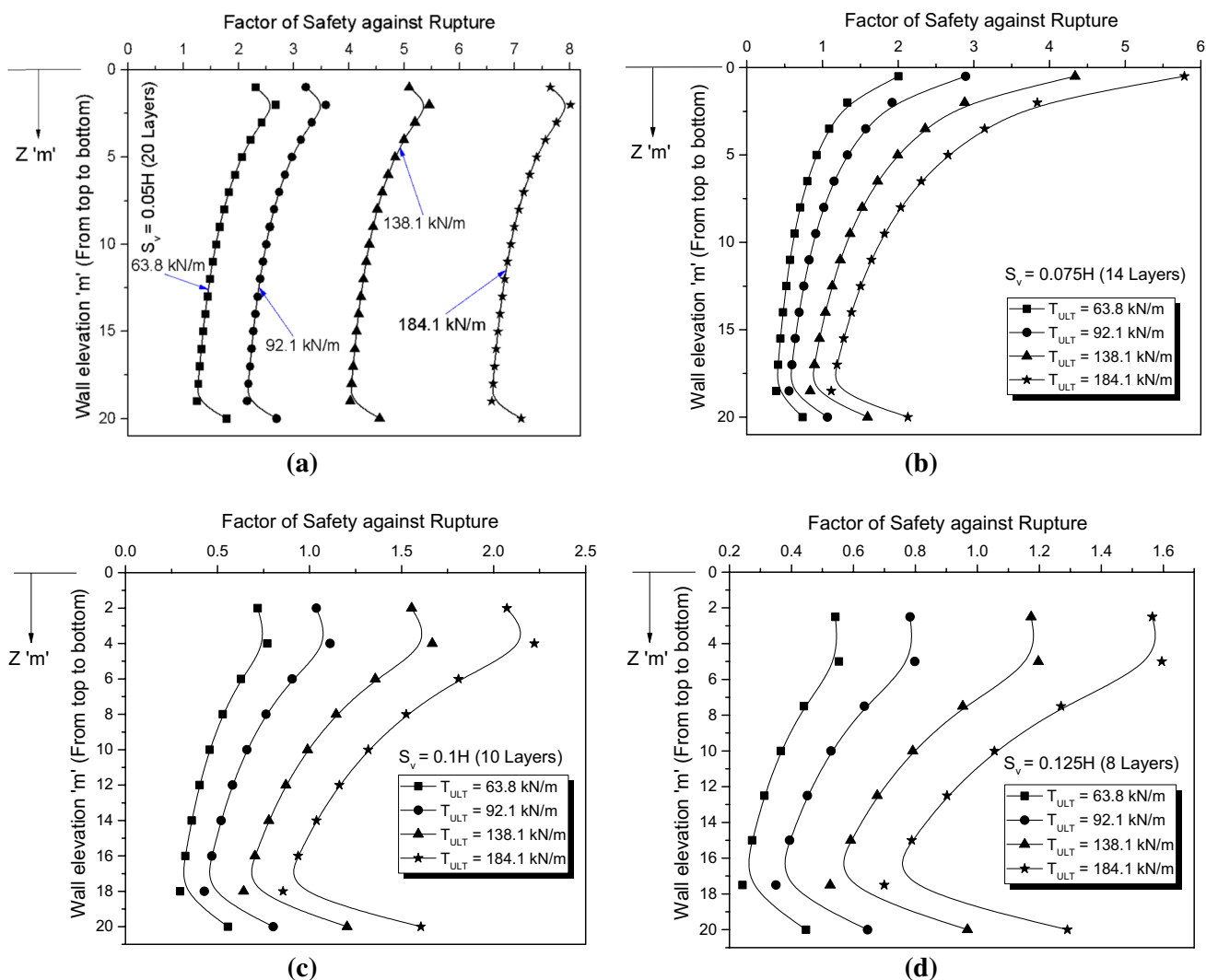

Fig. 15 FS against rupture of reinforcements with vertical spacing a $S_v = 0.05H$ b $S_v = 0.075H$ c $S_v = 0.1H$ and d $S_v = 0.125H$

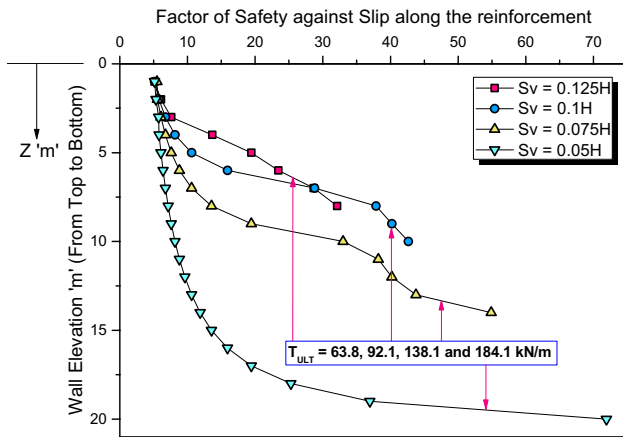

Fig. 16 FS against slip for wall with varying S_v of reinforcements

Table 9 Coefficient of interaction (C_i) values

S. no	Backfill Soil	ϕ	δ	C_i
1	GW	40°	37.05°	0.9
2	GP	38°	35.11°	0.9
3	GM	34°	28.35°	0.8
4	SW	36°	31.9°	0.85
5	SP	33°	28.9°	0.85
6	SM	29°	24°	0.8
7	Clay	(Not suitable for backfill)		0.6

Effect of Soil-Reinforcement Interaction

For this analysis, reinforcements of length, $L = 0.7H$ and $S_v = 0.05H$ are considered. Ultimate tensile strength of

reinforcement is 184.1 kN/m and a surcharge of 100 kPa is adopted in this analysis. Interaction between soil and reinforcement plays a vital role in the performance of the MBW wall, especially during the resistance against pull-out. Coefficient of interaction is given by, $C_i = \tan \delta / \tan \phi$; where, $\delta =$ angle of friction between soil and reinforcement, $\phi =$ Angle of internal friction of backfill soil. Softer the soil, the lesser will be interaction coefficient.

This coefficient varies for different types of soil. Values used in this study are tabulated in Table 9. Interaction between soil and reinforcements depends upon the percentage of fines in the backfill soils. From the Table 9, Coefficient of interaction (C_i) values considered for analysis are 0.9, 0.85, 0.8 and 0.6. For clayey soil, the value of the coefficient of interaction (C_i) is taken as 0.6. But clay cannot be considered as backfill soil as per the recommendations of AASHTO and FHWA. Percentage fines in the clayey soil will be more and permeability is very less. Drainage is a big concern in the case of clayey soil, which can be the cause for wall failure.

Effect of ' C_i ' on FS Against Pullout Failure

Maximum FS for pullout failure is around 60. Seismic coefficient of 0.5 is considered for analysis. For seismic analysis resistance for pullout is reduced by 30 to 35%. From Fig. 17a, it is clear that FS against pullout failure is very less for C_i value 0.6 (for clayey backfill). Maximum resistance for 20 layers wall system, with a value greater than 100. All the curves converge at the bottom of the wall. Pullout resistance is maximum at the bottom layers as the overburden pressure is maximum. Top four reinforcement layers are more critical for seismic conditions to resist pullout loads with a

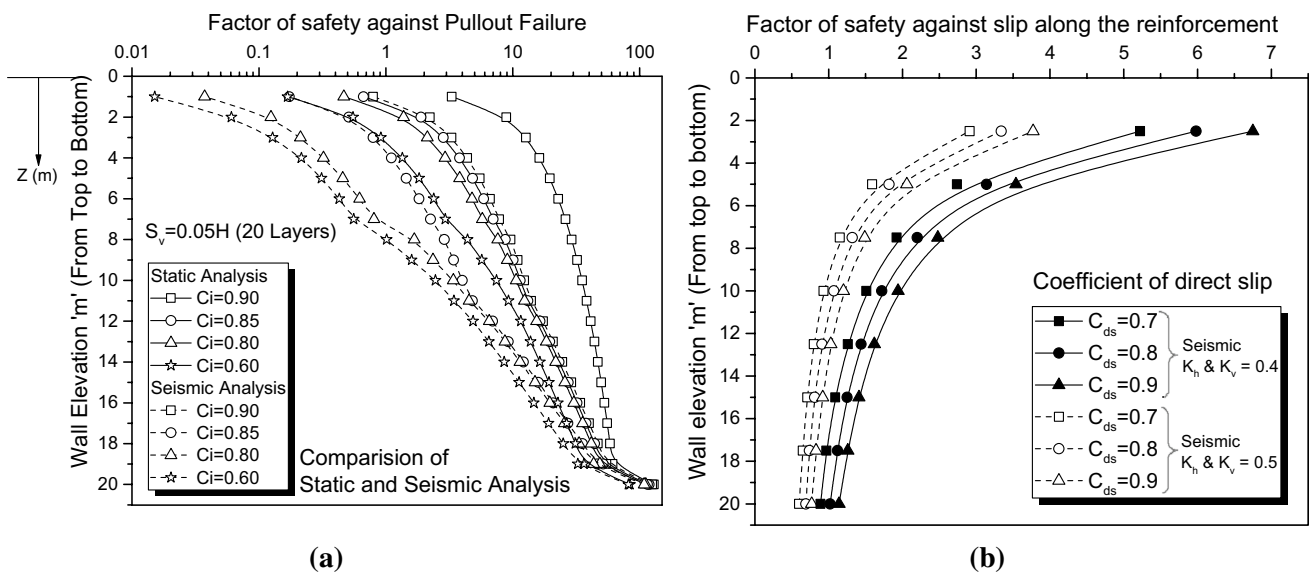

Fig. 17 a Effect of C_i on FS against pullout failure (20 layers) b Effect of C_{ds} on FS against slip (Seismic, k_h & $k_v = 0.4$ and 0.5)

coefficient of interaction values of 0.90, 0.85, 0.8 and 0.6. Bottom 50% of reinforcements are safe against pullout failure. Figure 17a, shows that pullout resistance is maximum for the reinforcements with the highest ‘ C_i ’ value. To obtain a good representation of pullout resistance values x-axis is considered with a logarithmic scale. Gravel and sand, as backfill are the most suitable soil to get better interaction with reinforcement to achieve higher pullout resistance.

Effect of the ‘ C_{ds} ’ on FS Against Slip along the Reinforcements Coefficient of direct slip C_{ds} is considered as 0.7, 0.8 and 0.9. FS against slip is minimum at the bottom reinforcement layers and maximum at the top layers. Slip resistance is directly proportional to the angle of internal friction of backfill soil and C_{ds} value. From Fig. 17b, it can be seen that earthquake has a significant effect on slip resistance. Coefficient of direct slip value of 0.9, shows higher safety factors against slip. For granular soils, the value of the coefficient of direct slip is greater than 0.8. Slip resistance offered by reinforcements also depends upon the internal water present in the reinforced block. The percentage difference is greater than 150% between static and seismic load (k_h & $k_v=0.4$ and 0.5) as seen in Fig. 17b.

Effect of Tensile Strength of Reinforcement

Internal stability of a wall with respect to different tensile strength values of reinforcements, FS against pullout failure and slip are same for all four different tensile strength of reinforcements, whereas FS against rupture differs as tensile strength used in the analysis are different.

FS Against Pullout Failure

Pullout resistance in the reinforcement is independent of the tensile strength of the reinforcement. FS against pullout loads mainly depends upon the force developed in the reinforcement and pullout resistance in the reinforcement. For all four tensile strength of reinforcement values, pullout resistance and forces in the reinforcement remains the same.

FS Against Slip along the Reinforcements As is seen from Fig. 18, FS against slip varies for an increase in a number of reinforcements. Whereas for all four selected tensile strength of reinforcement values FS against slip remains same. This safety factor depends upon the resisting horizontal force along the reinforcement and driving active horizontal force. These parameters are independent of values of tensile strength of reinforcement. The variation in Fig. 18 is due to the adaption of a different number of reinforcement layers.

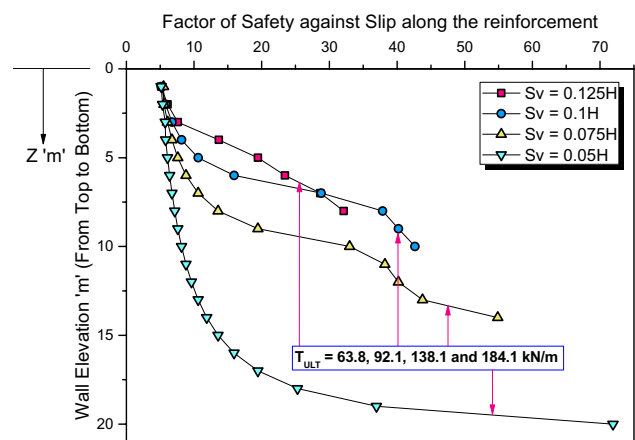

Fig. 18 FS against slip for different tensile strengths of reinforcement (8, 10, 14 & 20 Layers)

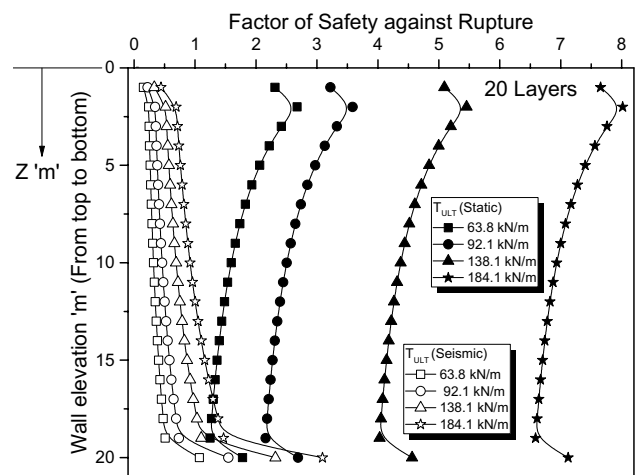

Fig. 19 FS against rupture for different tensile strength of reinforcement

FS Against Rupture FS against rupture is determined by dividing the tensile strength of the reinforcement with the force developed in the reinforcement. Since four reinforcements are used with varying tensile strength values, FS against rupture varies for different tensile strength of reinforcement values. 20 reinforcement layers are used as shown in Fig. 19. Static and seismic scenarios are compared. Seismic coefficient of 0.5 is taken for comparison. Due to seismic conditions, there is a decrease in FS against rupture by 85–90%. Maximum safety factor for rupture is observed to be nearly 8 with tensile strength 184.1 kN/m for static condition. At the 1st layer (extreme bottom layer), FS against rupture due to static and seismic loading conditions are very close. This may be due

to more overburden pressure at the bottom layer. In addition, bottom layers are attached with levelling pads, due to which, they are not subjected to excess tension loads.

Effect of Surcharge

To check the internal stability of the wall with respect to incremental surcharge loads, reinforcement with tensile strength 92.1 kN/m is considered. Well-graded gravel is considered as a backfill. 8 reinforcements are adopted with a vertical spacing of 0.125H to check the effect of surcharge on the internal stability such as., pullout safety factor, FS against slip and rupture.

FS Against Pullout Failure

From Fig. 20a, static loading and seismic coefficient of 0.1 is compared for different surcharge loads. Maximum pullout safety factor is near to 60 for surcharge load of 50 kPa. Percentage decrease in pullout safety factor due to an increase in surcharge loads is 10–12%. There is no significant decrease in pullout safety factors obtained for the seismic coefficient of 0.1. Percentage decrease in pullout safety factors due to the seismic coefficient of 0.1 compared with static loading condition is 3–5% as shown in Fig. 20a). At reinforcement #1 (bottom layer of the wall) pullout resistance is maximum. At reinforcement #1, the pullout safety factor for a surcharge of 200 kPa is nearly 44. This value is reduced by 4–5% with the influence of higher seismic coefficients. At the top layer, the pullout safety factor with respect to different surcharge loads have very close values for both static and seismic loading conditions. Pullout FS has increased by 63% from

reinforcement #2 to reinforcement #1 for seismic coefficient 0.4 and 0.5 as seen in Fig. 20b.

FS Against Rupture From Fig. 21a, it is observed that maximum FS for rupture is achieved for a surcharge load of 50 kPa. This FS has been reduced due to the increase in the surcharge loads. FS against rupture has increased with a greater number of reinforcements. As shown in Fig. 21a, for lesser vertical spacing of reinforcements (0.05H), FS for tensile or rupture resistance are very high, even for greater surcharge magnitudes.

FS against Slip Along the Reinforcements From Fig. 21b, a maximum safety factor against slip is observed for surcharge load of 50 kPa. It is maximum at the top layers and less at the bottom layers. Percentage change in safety factor against slip due to an increase in surcharge load is 10 to 12%. In Fig. 21b, the percentage decrease in FS against slip due to an increase in surcharge loads is 20–25%. Maximum FS against slip is 33 at the top reinforcement layer. Bottom layers show very less FS for slip.

Conclusions

Following are the conclusions drawn from the parametric study considering the effect of soil type, wall-fascia inclination, vertical spacing between reinforcements, soil reinforcement interaction, the tensile strength of reinforcement and surcharge magnitude.

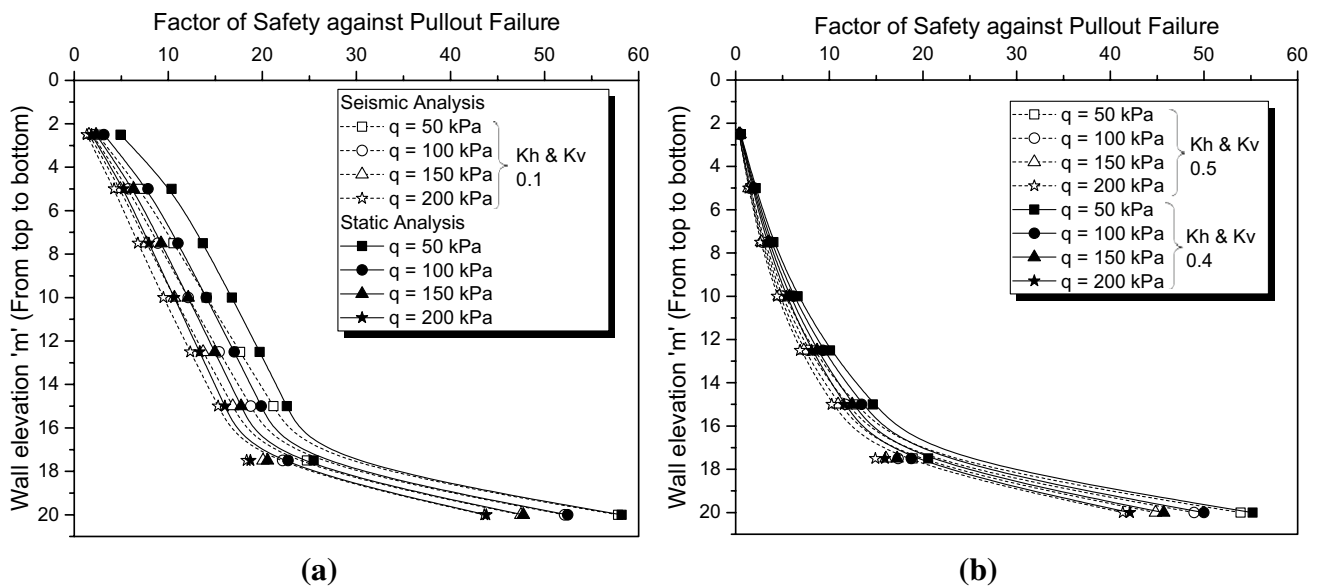

Fig. 20 FS against pullout failure for different q values a Static and Seismic, k_h & $k_v = 0.1$ b Seismic Analysis, k_h & $k_v = 0.4$ and 0.5

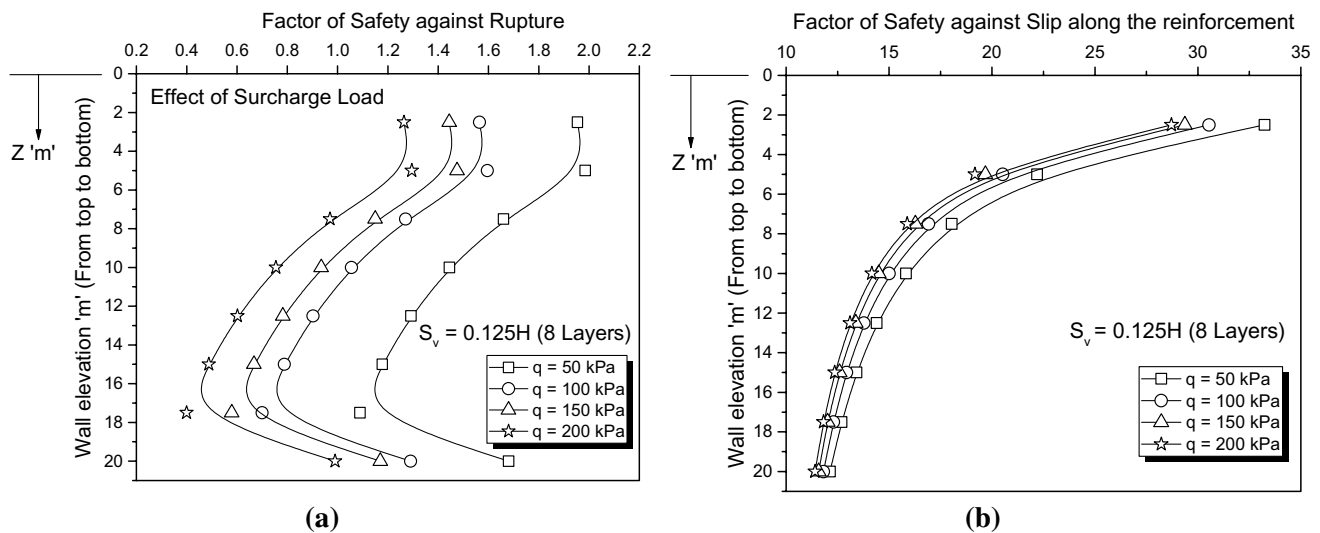

Fig. 21 a FS against rupture for different surcharge b FS against slip for different surcharge

- Internal stability results obtained from AASHTO, BS 8006 and China Railway code TB 10025 design guidelines for internal stability of MBW, shows that safety factors against pullout and rupture are in close range. There is a variation of 10 to 15% between these standard codes.
- Factor of safety against pullout and slip resistance are higher for backfill with GW. Backfill with SP or GM shows very close values for a factor of safety against pullout and slip resistance. Also, backfill with SW or GP shows nearly the same values of factor of safety against pullout and slip resistance. With an increase in seismic coefficient values by 0.1, pullout and slip resistance values are reduced by 4–5%. FS against rupture is independent of backfill soil, as the safety factors obtained for all soils are very close.
- FS against pullout failure is reduced by 15–50%, as the inclination angle increases from 50° to 90° . FS against rupture is reduced by 25–50% due to an increase in inclination angle. For higher inclination angles there is not much influence of seismic effect on rupture. When the wall face is gradually inclined slip resistance is reduced by 5 to 6%. For $\beta = 50^\circ$, slip resistance is very less compared with $\beta = 90^\circ$.
- For a greater coefficient of interaction between soil-reinforcement, higher are the pullout failure safety factors. Soil-panel friction coefficient can be maintained at least 0.6 to minimize the wall fascia deformations. The coefficient of interaction between soil reinforcement and coefficient of direct slip can be a minimum of 0.9 to achieve greater resistance against pullout and slip.
- Pullout and slip resistance in the reinforcement is independent of the tensile strength of the reinforcement. FS against rupture is maximum for higher tensile strength of

reinforcement values. With the increase in magnitudes of surcharge FS against overturning and sliding of the wall facing and reinforced block decreases. For lesser magnitudes of surcharge, FS against pullout, slip and rupture are maximum.

Thus, the recommendations derived from the results of this study give a better idea of understanding the behavior of the MSE wall associated with geotechnical materials. For researchers, this study helps to uncover areas in the MSE wall stability analysis. This research will be beneficial to MSE wall designers for the selection of appropriate materials in a design.

Author contribution statement AH and Anitha designed the model and the computational framework and analysed the data. AH and Anitha carried out the implementation. AH performed the calculations. AH and Anitha wrote the manuscript with input from all authors. GRD and CHS conceived the study and were in charge of overall direction and planning.

Declarations

Conflict of interest The authors have no conflicts of interest to declare. All co-authors have seen and agree with the contents of the manuscript and there is no financial interest to report. We certify that the submission is original work and is not under review at any other publication.

References

1. Koerner RM, Koerner GR (2013) A data base, statistics and recommendations regarding 171 failed geosynthetic reinforced mechanically stabilized earth (MSE) walls. *Geotext Geomembr* 40:20–27. <https://doi.org/10.1016/j.geotextmem.2013.06.001>

2. Karpurapu R, Bathurst RJ (1995) Behaviour of geosynthetic reinforced soil retaining walls using the finite element method. *Comput Geotech* 17(3):279–299. [https://doi.org/10.1016/0266-352X\(95\)99214-C](https://doi.org/10.1016/0266-352X(95)99214-C)
3. Reddy DV, Navarrete Fernando (2008) Experimental and analytical investigation of geogrid MSE walls. *Res Pract Geotechn Eng.* [https://doi.org/10.1061/40962\(325\)6](https://doi.org/10.1061/40962(325)6)
4. Leshchinsky D, Han J (2004) Geosynthetic reinforced multitiered walls. *J Geotech Geoenviron Eng* 130(12):1225–1235. [https://doi.org/10.1061/\(ASCE\)1090-0241\(2004\)130:12\(1225\)](https://doi.org/10.1061/(ASCE)1090-0241(2004)130:12(1225))
5. Samtani NC, Alexander DE (2005) Remediation of a failing MSE wall by jet grouting. *Geotech Special Publ.* [https://doi.org/10.1061/40783\(162\)24](https://doi.org/10.1061/40783(162)24)
6. Koerner RM, Koerner GR (2018) An extended data base and recommendations regarding 320 failed geosynthetic reinforced mechanically stabilized earth (MSE) walls. *Geotext Geomembr* 46(6):904–912. <https://doi.org/10.1016/j.geotextmem.2018.07.013>
7. Yang S, Gao Y, Cui K, Zhang F, Wu D (2020) Three-dimensional internal stability analysis of geosynthetic-reinforced earth structures considering seismic loading. *Soil Dyn Earthquake Eng.* <https://doi.org/10.1016/j.soildyn.2019.105979>
8. Konnur SS, Hulagabali AM, Solanki CH, Dodagoudar GR (2019) ‘Numerical analysis of MSE wall using finite element and limit equilibrium methods. *Lecture Notes Civil Eng.* https://doi.org/10.1007/978-981-13-0562-7_22
9. Hulagabali AM, Solanki CH, Dodagoudar GR, Shettar MP (2018) Effect of reinforcement, backfill and surcharge on the performance of reinforced earth retaining wall. *ARPN J Eng Appl Sci* 13(9):3324–3230
10. American Association of State Highway and Transportation Officials. (2010) AASHTO LRFD bridge design specifications, customary U.S. units.
11. BS8006-1. (2010) Code of practice for strengthened/reinforced soils and other fills. BRITI, July.
12. FHWA-NHI-10-024. (2009). Design and construction of mechanically stabilized earth walls and reinforced soil slopes–Volume I. Federal High Way Administration 178 (FHWA), I(November). FHWA-NHI-10-024 & FHWA-NHI-10–025.
13. NCMA (2012). Design manual for segmental retaining walls, National Concrete Masonry Association, 3rd Edition.
14. TB 10025 (2006). Code for design on retaining structures of railway subgrade. Railway & Train Industry Standard.

Publisher's Note Springer Nature remains neutral with regard to jurisdictional claims in published maps and institutional affiliations.

Springer Nature or its licensor (e.g. a society or other partner) holds exclusive rights to this article under a publishing agreement with the author(s) or other rightsholder(s); author self-archiving of the accepted manuscript version of this article is solely governed by the terms of such publishing agreement and applicable law.

