

TEXTILES — GENT'S COTTON BRIEFS PART 2 PLAIN KNITTED

Indian Standard IS 4046 (Part 2):2013, sets the standard for men's cotton briefs, specifically those that are plain knitted. It outlines the constructional details and requirements for these garments, aiming to standardize their quality and features. The Standard covers aspects like the design, fabric composition, elastic strap specifications, seams and stitches, dimensional requirements, and other characteristics such as colour fastness and pH value.

Fabric and Construction Details

The standard specifies two types of brief designs and their respective dimensions, along with the acceptable tolerances. The fabric used for the briefs should be bleached or dyed and meet specific construction parameters, including yarn count and mass per square meter. The standard also outlines the requirements for the elastic strap at the waistband, which can be either an outer woven strap or an inner woven strap formed by folding and stitching the fabric. In both cases, minimum width and mass requirements are specified, along with detailed specifications for the covered rubber threads used in the strap. The types of stitches and sewing thread count for different parts of the briefs are also defined, ensuring proper construction.

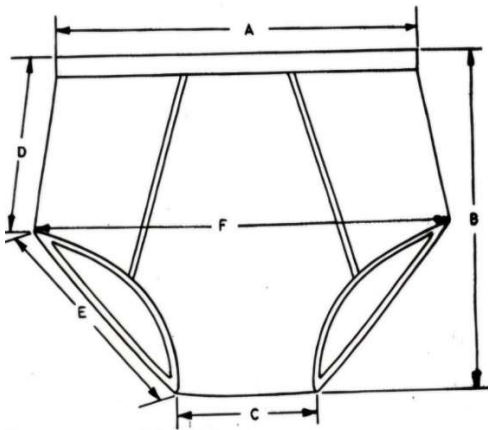

FIG. 1 TYPICAL SHAPE OF TYPE I BRIEFS

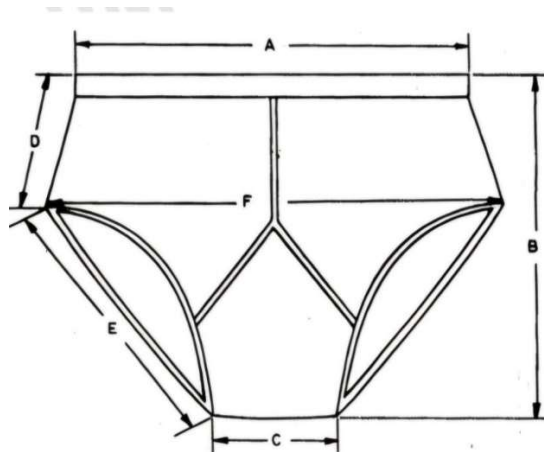

FIG. 2 TYPICAL SHAPE OF TYPE II BRIEFS

Additional Requirements

The standard defines tests for dimensional changes due to relaxation and the pH value of the aqueous extract to ensure quality and performance. Colour fastness to light, washing, perspiration, and rubbing is also tested to ensure the briefs maintain their appearance and colour over time. The Standard includes detailed procedures for conducting these tests.