

## From the Director General's Desk

**Shri Pramod Kumar Tiwari, IAS,  
Director General (DG), Bureau of Indian Standards (BIS)**

It gives me immense pleasure to present this reference handbook '**Connecting codes to classrooms: A Guide to Steel Structures Design**', a crucial reference for engineers, architects, students, and professionals involved in the construction and infrastructure development sector, notably in the area of Steel structures design. Bureau of Indian Standards (BIS) has always endeavoured to provide up-to-date, scientifically sound, and user-friendly guidelines, ensuring that India's infrastructure can stand tall on the global stage. This book is evidence to that commitment, summarizing the latest advancements, best practices, and innovations in the design of steel structures.



The author of this book has meticulously covered the entire spectrum of Steel structure design, from fundamental principles to detailed design procedures, ensuring a balance between theoretical concepts and practical applications.

At the Bureau of Indian Standards, we recognize the importance of continuous learning and improvement. The inclusion of practical insights in this book is aimed at bridging the gap between academic knowledge and field application. We hope that this resource will not only serve as a guide for current professionals but also inspire and educate the next generation of engineers and designers.

I extend my appreciation to the author and reviewers who have dedicated their expertise and time to this important work. I am confident that this book will be an essential tool for anyone involved in the design and construction of steel structures.

## ABOUT THE AUTHOR

The author of this book Mrs Rachna Sehgal, is currently working as Scientist G & Head (Ayush Department, Publication & Sales Department) in Bureau of Indian Standards working under Ministry of Consumer Affairs, Food and Public Distribution (Government of India).

Mrs Rachna has more than 32 years long and varied experience in all aspects of standardization at the National level, including promotion and implementation of standards and capacity-building activities in related areas. In addition, her comprehensive understanding of linkages between standards and trade, and of the implementation of standards, particularly through government policies has served Bureau in many ways.

A graduate in Civil Engineering from Delhi College of Engineering, Mrs Rachna also headed the International Relations Department and Water Resources Department of BIS. Prior to joining BIS, she began her career as a Structural Design Engineer.

The Standardization experience of the author extends beyond the National boundaries and she has also served as Committee Manager for ISO Committees pertaining to Hydrometry viz ISO/TC 113, ISO/TC 113/SC 1 and ISO/TC 113/SC 6. She has also been associated with ISO committee for Developing countries as Lead of DEVCO WG1/TG1 and Member of the ISO Patent Policy Group (PPG).

Her vast experience in varied fields and keen interest to pass on the legacy of Standards to different stake holders for the development of Nation as a whole has taken the shape of this book.



## FROM THE WRITER'S DESK

I would like to take this opportunity to express my deepest gratitude to all those who have contributed to the successful completion of this book, '**Connecting codes to classrooms: A Guide to Steel Structures Design**'.

First and foremost, I extend my heartfelt gratitude to the Mr Pramod Kumar Tiwari, IAS (*AssamMeghalaya cadre* 1991) Director General of the Bureau of Indian Standards (BIS) for his invaluable encouragement, insightful guidance, and constant motivation. His visionary support has been instrumental in shaping the content of this work.

I am profoundly grateful to Mr Mohammad Aqib for his valuable inputs on the section on methods of tests and contributions for the section on Informative Material. His expertise and efforts in gathering the data have provided a solid foundation for this book.

I would also like to extend my appreciation to all the staff members of the Publication department in BIS who assisted in drafting and reviewing the manuscript. Their dedication, attention to detail, and collaborative spirit have been crucial in shaping the final version of this book.

I am grateful to everyone who has been a part of this work, and would like to thank them for their unwavering support and contribution.

While every effort has been made to make this as comprehensive as possible, any suggestions on improvement with regard to the content of the handbook are the most welcome.

## PREFACE

Standards are the cornerstone of the quality infrastructure of a country, playing a crucial role in achieving and maintaining a minimum level of quality of products and services offered to consumers.

Bureau of Indian Standards (BIS) is the national standards body of India, having formulated over 22000 standards on diverse sectors such as Textiles, Electronics and Information Technology, etc. Indian Standards, formulated by Bureau of Indian Standards, represent the expertise of relevant stakeholder categories and the best practices nationally and internationally.

BIS, as the national standards body and also India being a signatory to the WTO TBT Agreement, follows the six principles for the development of standards laid down under the Annex 3 Code of Good Practice for the Preparation, Adoption and Application of Standards of the TBT Agreement. The principles, namely, transparency, openness, impartiality and consensus, effectiveness and relevance, coherence and development dimension, are fundamental in BIS standardization practices, helping ensure that the standards formulated represent concerns of the broadest spectrum of stakeholders, and are as inclusive and as acceptable as practically possible.

BIS is engaged in standards formulation in almost all sectors of economy and technology. In the area of civil engineering, the standardization is done through its Civil Engineering Division Council (CEDC). The CEDC achieves these objectives through various Sectional Committees functioning under it. At present, there are 38 Sectional Committees catering to various sub-domains under civil engineering.

During the last around seven decades, the Council has been able to bring out over 1900 Indian Standards in the following broad areas:

- a) Planning and functional requirements
- b) Building materials and components including their testing and test equipment
- c) Geo-technical engineering
- d) Structural design and disaster resilient structures and development, including safety against natural disasters like earthquake, landslide and cyclone
- e) Fire fighting and fire safety
- f) Good construction practices including safety during construction
- g) Construction project management
- h) Building services, like lighting, ventilation and acoustics
- i) Public health engineering including plumbing services, such as water supply drainage and sanitation
- j) Measurement of works
- k) Special structures like composite structures, tall buildings, broadcasting/transmission line towers, cooling towers, water tanks, bins, silos, ports and harbours, off-shore installations, etc.

The country is on the path of rapid development and urbanization. World-class infrastructure has to be put in place to support the current development push being given in the country. Steel structures such as Skyscrapers, bridges and transmission tower, refineries, high rise buildings, industrial buildings, industrial sheds, etc are contributing towards changing the landscape of the country, that requires adhering to highest level of quality standards.

Some of the important committees of BIS involved in formulation of standards relevant to steel structures are as given below:

**a) CED 07, Structural Engineering and Structural Sections Sectional Committee**

*Scope* - Standardization in the field of structural engineering using steel/ aluminium structural sections, dimensions/tolerances of various hot rolled/cold formed sections, bars and flat products in steel and aluminium for structural and general engineering applications including pipelines.

*Liaison* :

ISO TC 167 - Steel and aluminium structures

**b) CED 37, Structural Safety Sectional Committee**

*Scope*: Standardization in the field of structural safety including loading standards

*Liaison* :

ISO TC 98 - Bases for design of structures

ISO TC 98 / SC 1 - Terminology and symbols

ISO TC 98 / SC 2 - Reliability of structures

ISO TC 98 / SC 2 - Design principles of seismically isolated structures

ISO TC 98 / SC 3 - Loads, forces and other actions

ISO TC 98 / SC 3 - Wind actions on structures

**c) CED 39, Earthquake Engineering Sectional Committee**

*Scope*: Standardization in the field of design and construction of earthquake resistant structures and in the field of instruments and tests connected therewith.

*Liaison* :

ISO TC 98 / SC 3 - Wind actions on structures

**d) MTD 04, Wrought Steel Products Sectional Committee**

*Scope*: Standardization in the field of steel and wrought steel products including classification, designation and coding of steels.

*Liaison* :

ISO TC 17 - Steel and its various sub-committees

IEC TC 68 - Magnetic alloys and steels



Acknowledging the significance of Indian Standards for the future engineers, the curriculum of Civil Engineering is designed in a manner, to provide an exposure of Indian Standards on some relevant aspects. Some of the Indian Standards and Special Publications formulated by BIS in the Civil Engineering sector are referred to by Technical Institutes in the Civil Engineering curriculum. For instance, IS 800 ‘General Construction in Steel’ and National Building Code of India are central to the curriculum of most Technical Institutes for their graduate course for Civil Engineering.

While these documents are drafted in a manner that those are simple to comprehend, these can be voluminous and may require efforts in establishing link between the individual subjects covered in the course and the corresponding clauses of these documents.

As there was no existing literature available that links the syllabus of Civil Engineering courses and BIS standards, a need was felt to effectively map these in clear and simple manner. The curriculum of Civil Engineering course of several prominent Technical Institutes have been examined, and mapped with Indian Standards and Special Publications, namely, National Building Code of India and Handbook for Structural Engineers, establishing the central role of Indian Standards for Civil Engineers.

Relevant Indian Standards formulated by the Civil Engineering Division Council (CEDC) and Metallurgical Engineering Division Council (MTDC) have been considered for linking the relevant requirements in the documents with the curriculum.

This reference handbook integrates the learning methodology with practical aspects of designing, accommodating the rich experience contained in the relevant Indian Standards. The blend of learning experience will help students to make their learning more meaningful and intends to serve as a foundation to build a stronghold in the field of Civil Engineering, thereby aiding them in delivering their role as a Civil Engineer. This handbook draws on the extensive material base from latest Indian Standards available on the subject. Primarily, IS 800 ‘General Construction in Steel — Code of Practice’ and **SP 7** ‘National Building Code of India’ (Part 6/Sec 6) deal with design of Steel structures that have been considered for this purpose. Loading has been taken from **IS 875** (*issued in parts*). **IS 1893 (Part 1)** and **IS 18168** have been referred for seismic loads, design and detailing. Several other standards on various aspects such as materials, testing, etc are also necessary adjunct to the above, which have been elaborated in subsequent sections.

The original text has been retained in the interest of providing necessary background to the continuing technical developments. However, users of this reference book are encouraged to refer latest editions of the Indian Standards to gain deep insight on various aspects of the subject. The indigenous Indian Standards can be downloaded free of cost from BIS website [www.bis.gov.in](http://www.bis.gov.in) or using the link <https://standardsbis.in>.

# CONTENTS

*Introduction*

*Design of Steel Structures — Comprehensive Flow Chart*

**Chapter 1      STEEL**

Steel, Classification Based on Steel Making, Classification Based on Chemical Composition

**Chapter 2      TERMINOLOGY**

Terminology

**Chapter 3      INDIAN STANDARDS ON STEEL**

Hot Rolled Medium and High Tensile Structural Steel, Cold Reduced Carbon Steel Sheet and Strip, Cold-Formed Light Gauge Steel Structural Members in General Building Construction, Steel Tubes in General Building Construction, Hot Rolled Carbon Steel Sheet, Plate and Strip

**Chapter 4      IMPORTANT PROPERTIES OF STEEL AND TEST METHODS**

Tensile Test, Bend Test, Impact Test, Hardness Test

**Chapter 5      LOADS, FORCES AND EFFECTS**

Introduction, Dead Load, Imposed Load, Wind load, Seismic Force, Snow Load on Roof(s), Special Load, Load Combination, Multi-Hazard Risk in Various Districts of India

**Chapter 6      DESIGN OF STEEL STRUCTURES**

Materials, General Design Requirements, Methods of Structural Analysis, Limit State Design, Design of Tension Members, Design of Compression Members, Design of Members Subjected to Bending, Design of Members Subjected to Combined Forces, Connections, Working Stress Design

**Chapter 7      EARTHQUAKE RESISTANT DESIGN**

Materials, Design Requirements, Beams, Columns, Beam-Column Joint, Column Base, Structural Braces, Shear Links, Special Requirements for Structural Systems, Structural Systems, Fatigue, Design Assisted by Testing, Durability, Fabrication and Erection, Analysis and Design Methods, Design Against Floor Vibration, Connections

**Chapter 8      INFORMATIVE MATERIAL**

Annex A — About Bureau of Indian Standards (BIS)

Annex B — Some Initiatives by BIS for Collaboration with Academic Institutions

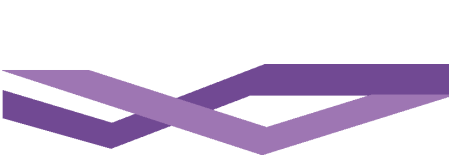

Annex C — Overview of Civil Engineering Department, Bureau of Indian Standards

Annex D — CED 07 Structural Engineering and Structural Sections Sectional Committee

Annex E — Indian Standards Related to Structural Steel (Metallurgical Engineering Department)

Annex F — Steel and Iron Products Under Compulsory

Certification of BIS

Annex G — Important Policies and Initiatives of Government of India

Annex H — Standardization on the Subjects under BIS and other International Standards Setting Bodies

Annex J — Mapping of Academic Curriculum with Indian Standards



# INTRODUCTION

# INTRODUCTION

## WHY STEEL?

One of the primary reasons driving consumers towards steel construction is its inherent strength and durability. Steel structures have a high strength-to-weight ratio, allowing for lighter and better designs without compromising on structural integrity. This durability leads to longevity, as steel structures are less susceptible to wear and tear, corrosion, and environmental factors compared to concrete. Moreover, steel construction offers greater design flexibility and versatility. With advancements in technology and fabrication techniques, steel can be moulded and shaped into virtually any form. Another important factor driving the preference for steel construction is sustainability. Unlike concrete, which relies heavily on cement production — A process associated with high carbon emissions — Steel is a highly recyclable material. The recyclability of steel not only reduces the environmental footprint but also aligns with growing consumer demand for eco-friendly building practices. Skyscrapers, bridges and transmission tower, Refineries, high rise buildings, industrial buildings, industrial sheds, etc are made of steel.

## National Standards on Steel — A Background

Steel, as a very important basic raw material for industrialization, had been receiving attention from the Planning Commission from the very early stages of the country's First Five Year Plan. The Planning Commission not only envisaged an increase in production capacity in the country but also considered the question of even greater importance, namely, the taking of urgent measures for the conservation of available resources. Its expert committees came to the conclusion that a good proportion of the steel consumed by the structural steel industry in India could be saved if higher efficiency procedures were adopted in the production and use of steel. The Planning Commission, therefore, recommended to the Government of India that the Indian Standards Institution (now Bureau of Indian Standards) should take up a Steel Economy Project and prepare a series of Indian Standard specifications and codes of practice in the field of steel production and utilization. Accordingly, Indian Standards on Steel were formulated through deliberations at numerous sittings of committees, panels and study groups. The standards covered steel production, design and use of steel. Thereafter, in order to guide the engineers in the use of various Indian Standards, Bureau of Indian Standards (*BIS*) erstwhile Indian Standards Institute (*ISI*), also undertook preparation of a number of handbooks.

## Significance of having National Standards for Design of Steel Structures

Following National Standards for Design of Steel Structures enable engineers to design structures that can withstand various loads and environmental conditions, thereby reducing the risk of structural failure. Standards set benchmarks for material properties, fabrication processes, and construction methods and incorporate design principles that have been validated through research and practice, ensuring the safety and reliability of structures. They also help maintain high quality in materials and construction practices, optimize material usage, reduce wastage and lower costs. Further, *BIS* strives to regularly update Indian Standards to reflect cutting edge technological developments and global best practices in the field.

Through this book, attempt has been made to familiarise the academia with the Indian



Standards formulated by Bureau of Indian Standards for design of steel structures by providing an overview of Indian Standards on classification of steel, basic terminology on steel, salient test methods for testing of steel, loads and its effects and design of steel structures. Detailed guidance can be availed on each aspect by referring to the corresponding Indian Standards. Informative annexures provided at the end of the book, particularly on the association of BIS with academia will be of interest to the students and teaching faculty. The purpose of this book will be fulfilled if students become aware of Indian Standards relevant to their curriculum and enrich their knowledge by referring to the standards and they are better prepared to design steel structures when they enter their profession after completing their education successfully.

# IMPORTANT INDIAN STANDARDS RELEVANT TO DESIGN OF STEEL STRUCTURES (LOADS)

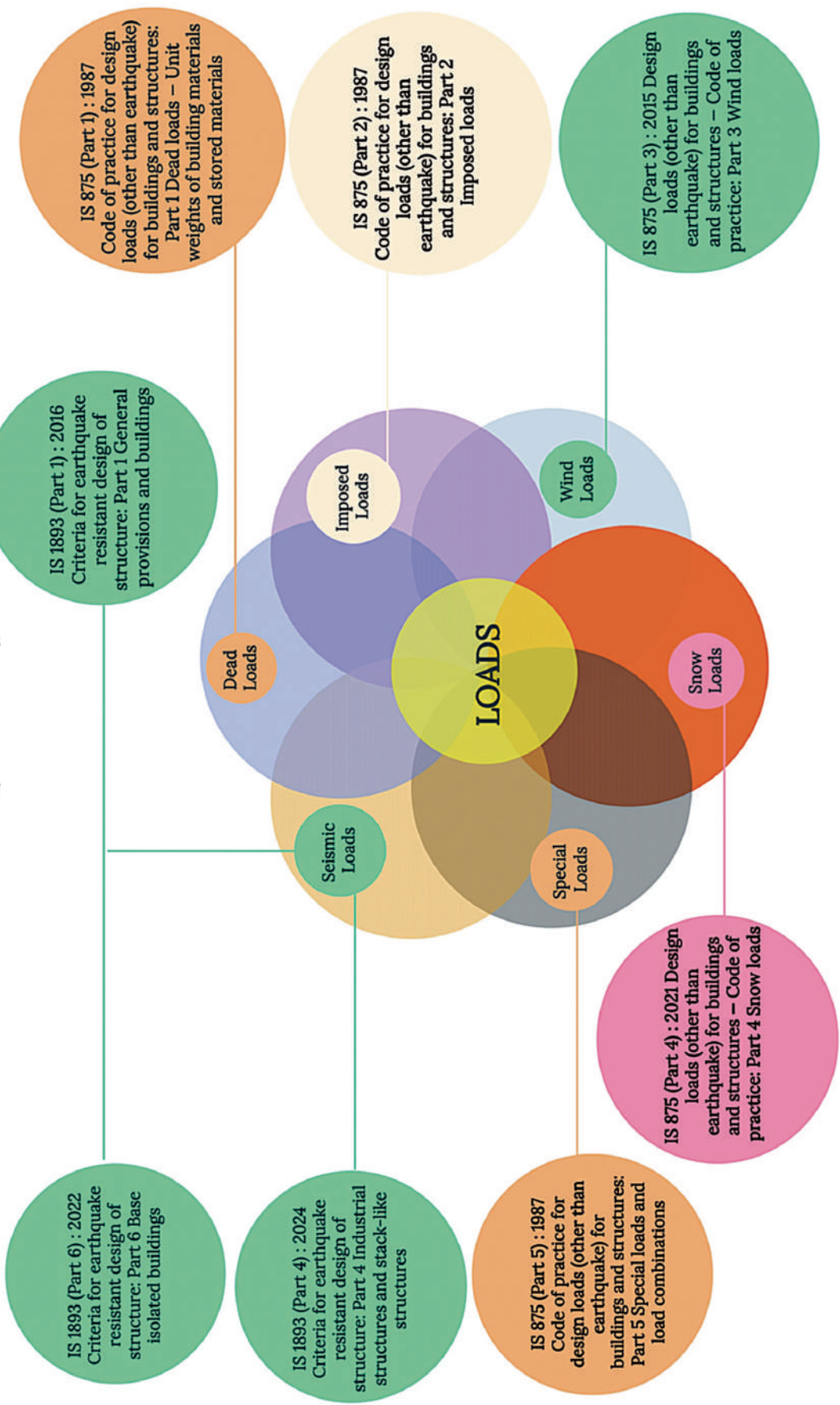

# IMPORTANT INDIAN STANDARDS RELEVANT TO DESIGN OF STEEL STRUCTURES

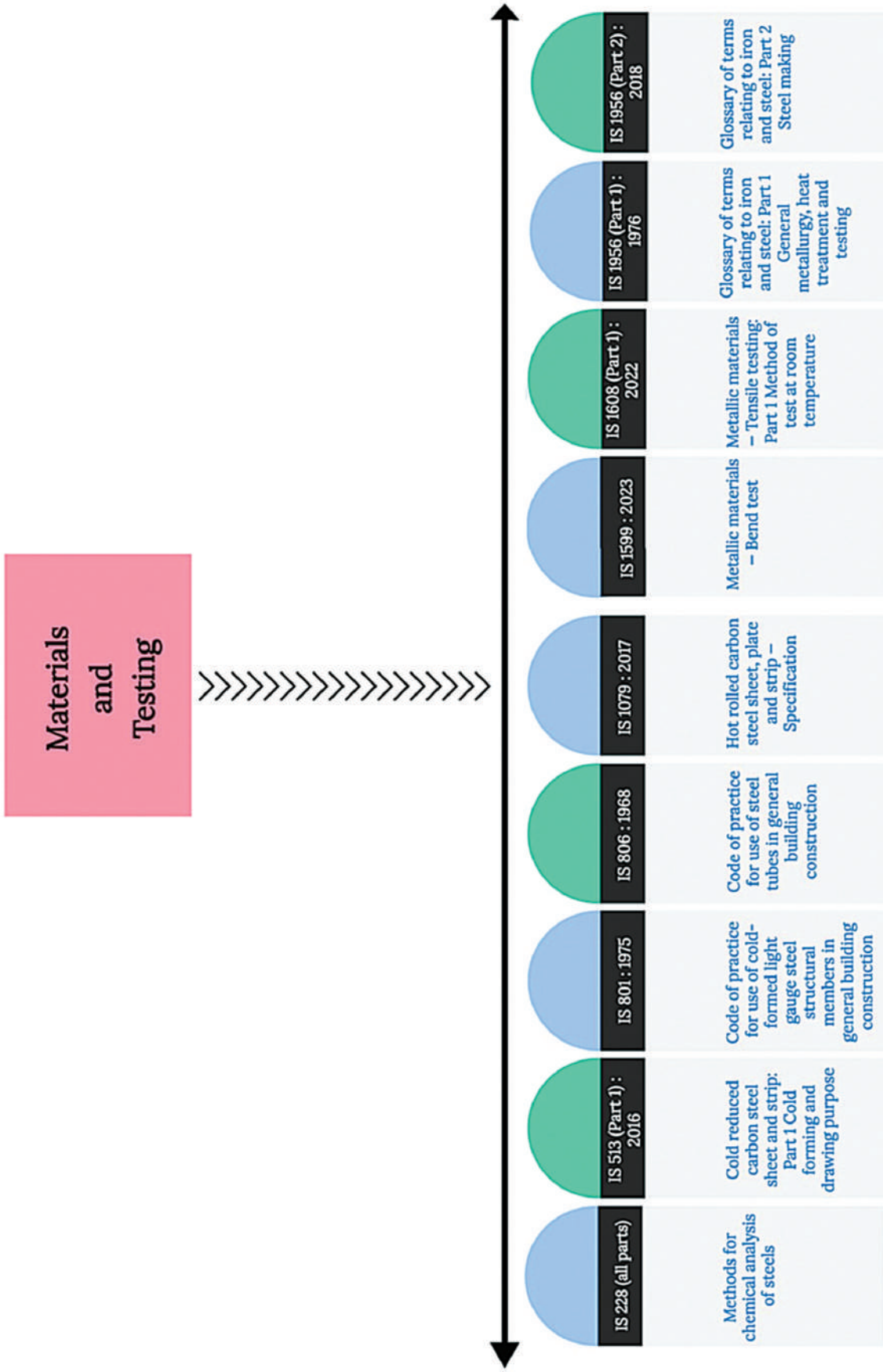

# IMPORTANT INDIAN STANDARDS RELEVANT TO DESIGN OF STEEL STRUCTURES

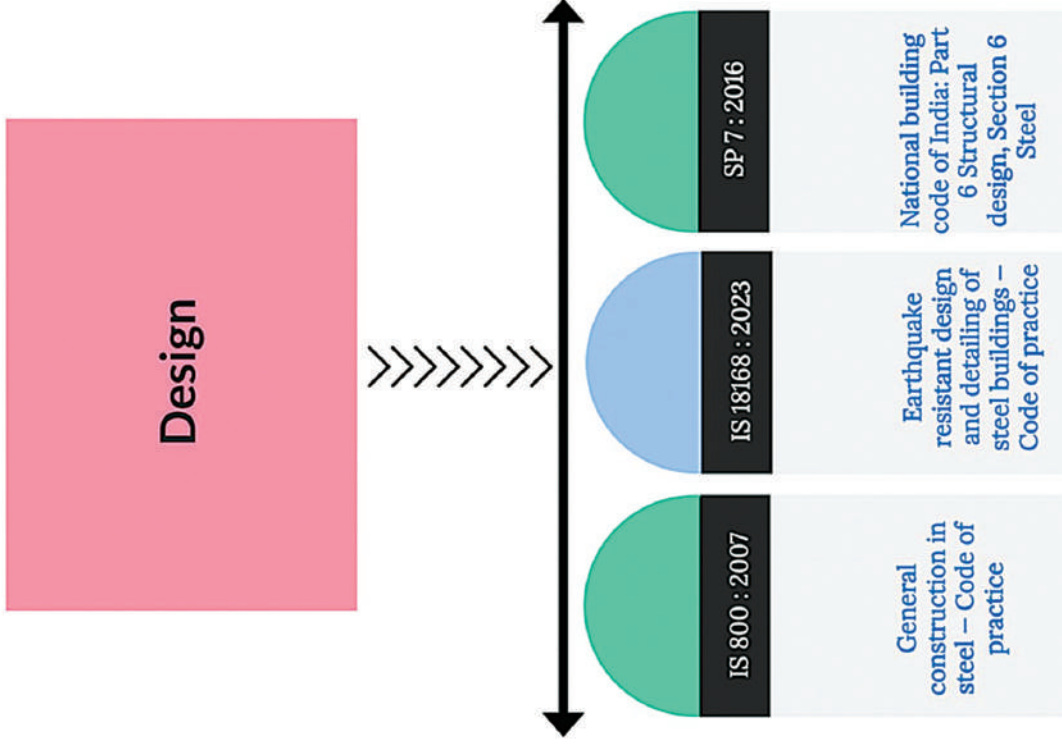

# IMPORTANT INDIAN STANDARDS RELEVANT TO DESIGN OF STEEL STRUCTURES

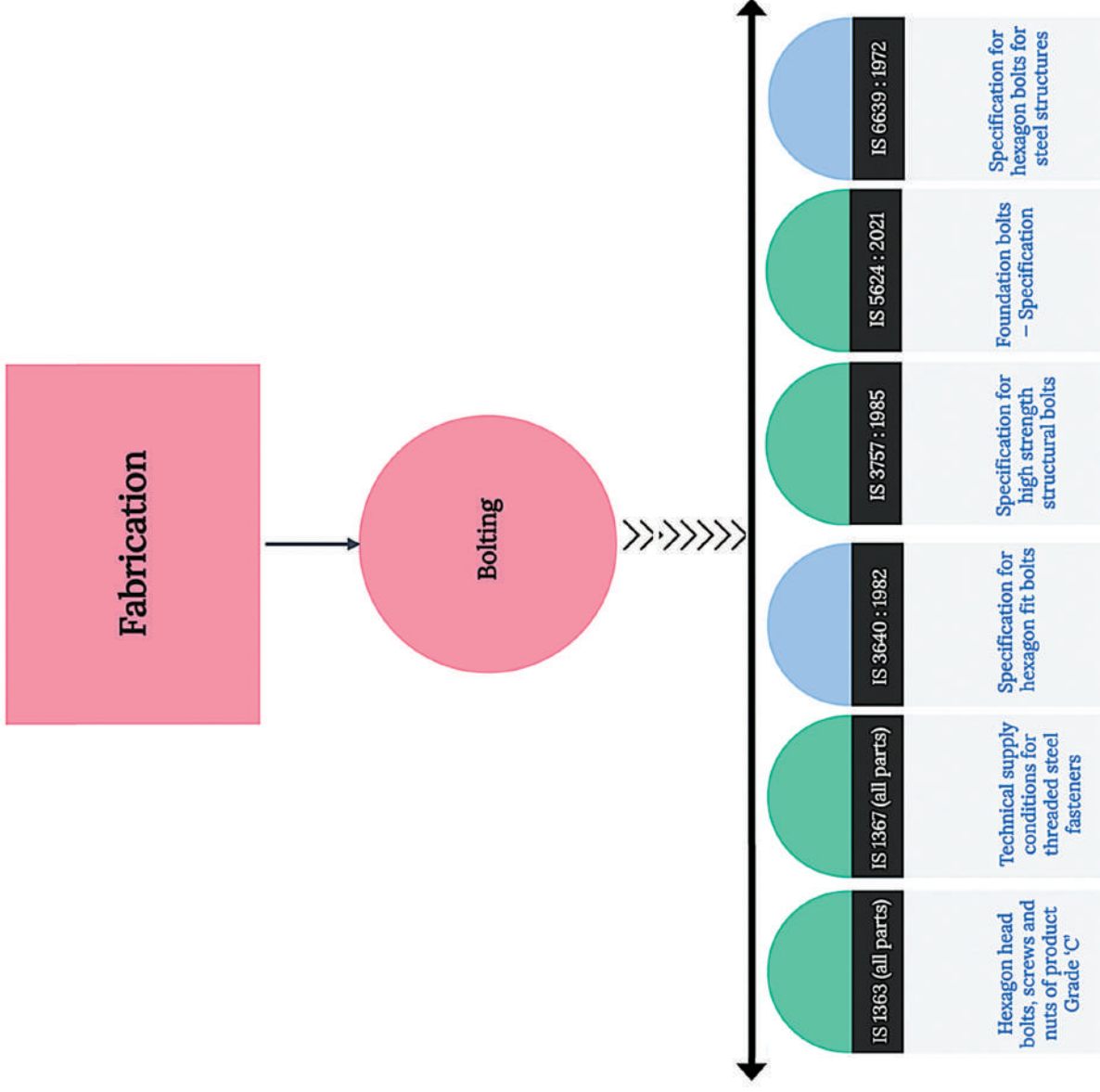

# IMPORTANT INDIAN STANDARDS RELEVANT TO DESIGN OF STEEL STRUCTURES

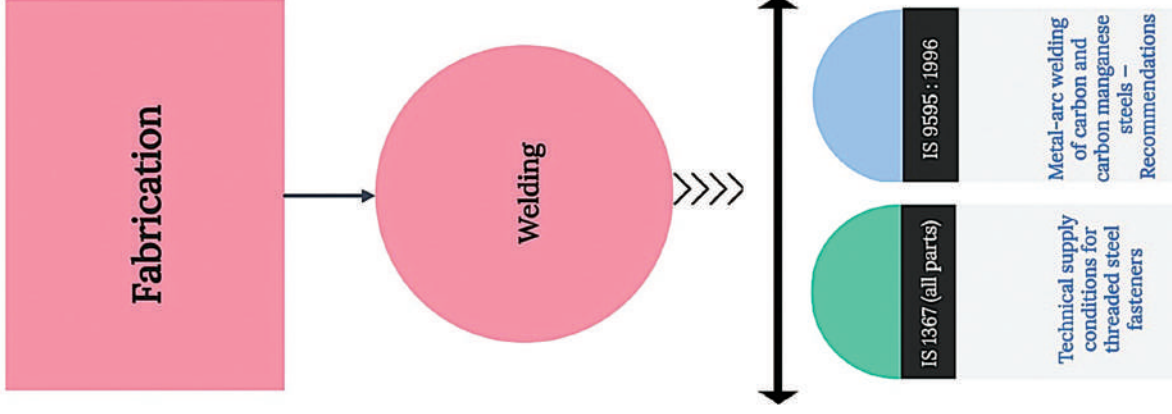



# IMPORTANT INDIAN STANDARDS RELEVANT TO DESIGN OF STEEL STRUCTURES

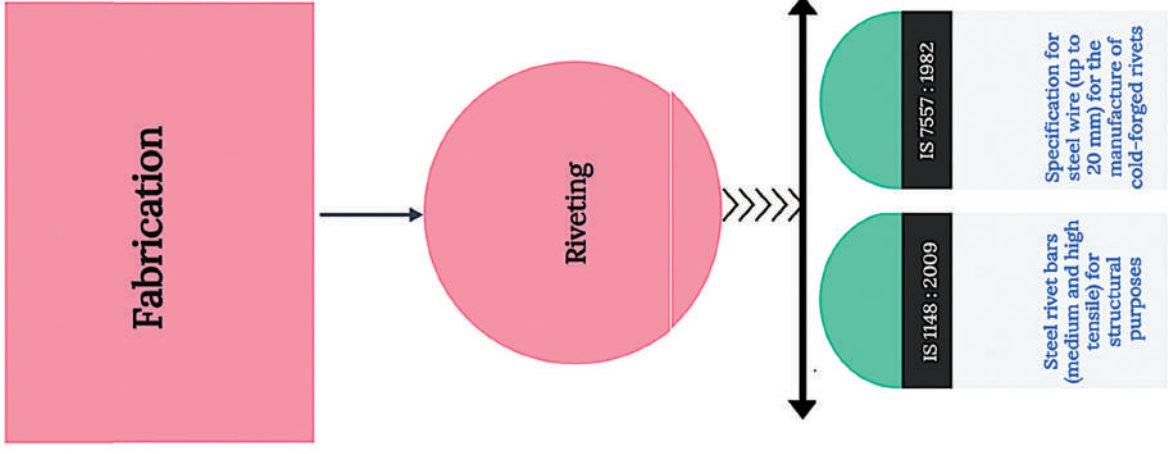



# **CHAPTER I**

## **CLASSIFICATION OF STEEL**

# CHAPTER I

## CLASSIFICATION OF STEEL

### INTRODUCTION

This section covers classification of steels based on steel making methodology and chemical composition as covered by Indian Standards.

Indian Standard **IS 1956 (Part 2)** covers definitions of the terms commonly used in the field of steel making and classification of steel.

### I. STEEL

Steel is an iron base alloy generally suitable for working to the required shape in the solid state having a carbon content generally less than 1.5 percent and containing varying amounts of other elements. A limited number of high alloyed steels may have more than 2 percent carbon, the usual separator between steel and cast iron. This section covers classification of steels based on steel making methodology and chemical composition as covered by Indian Standards.

Steel is classified on following basis:

- a) Classification based on steel making;
- b) Classification based on chemical composition.

### II. CLASSIFICATION BASED ON STEEL MAKING

Indian Standard IS 1956 (Part 2) covers classification of steel based on steel making. Steel is majorly classified in the following types:

#### Rimming Steel

A steel possessing a rim of purer material (with maximum freedom from surface blemishes) and is associated with evolution of carbon monoxide gas occurring due to the interaction of dissolved iron oxide and carbon during the solidification of low carbon and low manganese steel made under controlled deoxidation. The composition and extent of the rim can be varied and if required, the rimming action can be arrested after sometime.

#### Balanced Steel (Semi-killed and Semi-rimmed Steel)

Steel to which controlled amounts of deoxidizers have been added in the liquid stage during tapping and teeming, the object being to reduce the severity of piping. This steel is intermediate between killed and rimming types.

#### Capped Steel

It is a rimming steel in which the depth of the rim is controlled by arresting the rimming action, at the appropriate time. The rimming action can be arrested mechanically by putting a heavy steel plate on the top of the surface of the ingot (mechanical capping), or can be stopped by killing, with the addition of deoxidizers on

the ingot top (chemical capping). The rimming action can also be stopped by spraying water on the top of the ingot.

### **Killed Steel (Solid Steel)**

Steel which has been fully deoxidized to reduce the oxygen content of the steel to a minimum in order that no reaction takes place between carbon and oxygen during solidification. **Plugged Steel**

It is rimming steel poured in a bottle shaped mould with a central plug. The rimming action is arrested when the metal rises and comes in contact with the bottle portion of the mould and the central plug. **Special Steel**

Steel in the production of which special care has to be taken so as to attain the desired cleanliness, surface quality and mechanical properties.

## **III. CLASSIFICATION ON THE BASIS OF CHEMICAL COMPOSITION**

### **Unalloyed Steels**

Unalloyed steels are those steels in which specified content of any element is less than that indicated below:

<b>Constituent</b>	<b>Percentage</b>
Aluminium	0.10
Boron	0.00018
Bismuth	0.10
Chromium	0.30
Cobalt	0.10
Copper	0.40
Manganese	1.65 <sup>1</sup>
Molybdenum	0.08
Nickel	0.30
Niobium	0.06
Lead	0.40
Selenium	0.10
Silicon	0.50
Tellurium	0.10
Titanium	0.05
Tungsten	0.10
Vanadium	0.10
Zirconium	0.05
Lanthanides (each)	0.05
Other specified elements (except S, P, C and N)	0.05
If only a maximum is specified for the manganese content of the steel the boundary shall be at 1.80 percent.	

NOTE — Limits specified in the table for the following elements shall not be considered for custom tariff purposes for demarcating unalloyed and alloy steels, unless otherwise agreed to:

- a) bismuth;
- b) lead;
- c) selenium;
- d) tellurium; and
- e) lanthanides and other specified elements (except S, P, C and N).

### **Low-carbon Steels**

Low-carbon steels are unalloyed steels containing up to 0.30 percent carbon.

### **Medium-carbon Steels**

Medium-carbon steels are unalloyed steels containing carbon between 0.30 percent to 0.60 percent.

### **High-carbon Steels**

High-carbon steels are unalloyed steels containing carbon more than 0.60 percent.

Where the elements are defined only by maximum values, 70 percent of these maximum values shall determine the class of the steel.

### **Alloy Steel**

Alloy steels are those steels where specified content of any element is equal to or greater than that indicated in unalloyed steels.

Depending on the alloy content (exclusive of S, P, C and N), alloy steels shall be subdivided as follows:

### **Low Alloy Steels**

Low alloy steels are steels in which total alloying elements are up to and including 5 percent.

### **Medium Alloy Steels**

Medium alloy steels are steels in which total alloying elements are more than 5 percent but up to and including 10 percent.

### **High Alloy Steels**

High alloy steels are steels in which total alloying elements are more than 10 percent.



# **CHAPTER II**

# **TERMINOLOGY**

## CHAPTER II

# TERMINOLOGY

### INTRODUCTION

This section covers terminology related to steel sections and their testing, loading and design of steel structures. Indian Standard IS 1956 (Part 1) covers terms commonly used in the field of general metallurgy, heat treatment and testing. IS 800 covers terminology pertaining to design of steel structures. Some of the commonly used terms are given below:

**Accidental Loads** — Loads due to explosion, impact of vehicles, or other rare loads for which the structure is considered to be vulnerable as per the user.

**Action** — The primary cause for stress or deformations in a structure such as dead, live, wind, seismic or temperature loads.

**Ageing** — A change in properties which may occur gradually with time at atmospheric temperatures (natural ageing) and more rapidly at elevated temperatures (artificial or accelerated ageing).

**Angles, Shapes & Section** — Hot rolled Structural Sections obtained by hot rolling of blooms/billets. They include angles, channels, girders, joist, I beams, H beams etc used in civil/mechanical construction.

**Annealing** — Heating to and holding at a suitable temperature, followed by cooling at a suitable rate, for inducing softness.

**Bars & Rods** — Long steel products obtained normally by hot rolling/forging of billets/blooms.

They include Rounds, Flats (flat bars), Squares, Hexagons, Octagons etc. which find direct use in a wide variety of products in Engineering & Agricultural, House hold, Furniture sector etc. with/without further processing.

**Beam** — A member subjected predominantly to bending.

**Billets** — A semi-finished product which are similar to blooms but of smaller cross sectional size

(usually less than or  $5' \times 5'$ / $7' \times 7'$ . These are used as input material for production of Finished Steel long products viz. bars & rods, light sections etc.

**Blooms** — A Semi-finished product, usually in square (at times in rectangular) section of cross sectional size exceeding  $5" \times 5"$  ( $125 \times 125$  mm). In some of the modern mills, the term bloom is used to cover such products of cross sectional size exceeding  $8" \times 8"$ . These are inputs for producing Heavy sections and sheet piling section normally by hot rolling. At times, like in VSP, blooms are used to produce billets by hot rolling in the billet mill.

**Breaking Strength** — Breaking load at the time of fracture divided by the original cross-sectional area of the test piece.

**Characteristic Load (Action)** — The value of specified load (action), above which not

more than a specified percentage (usually 5 percent) of samples of corresponding load are expected to be encountered.

**Characteristic Yield/Ultimate Stress** — The minimum value of stress, below which not more than a specified percentage (usually 5 percent) of corresponding stresses of samples tested are expected to occur.

**Cold Rolled (CR) Strips** — are produced by cold rolling of HR strips in cold rolling mills (normally at room temperature). CR strips are cut to produce CR sheet. CR strips/sheets are characterised by lower thickness, better/bright finish, closer dimensional tolerance and specific mechanical/metallurgical properties. They are directly used in automobiles (cars/scooters, motorcycles etc), white goods, consumer durable etc. or for production of coated sheet products.

**Column** — A member in upright (vertical) position which supports a roof or floor system and predominantly subjected to compression.

**Creep** — The continuous flow of a metal or alloy when stressed below its yield point or proportional limit. It is more marked at elevated temperatures and is, therefore, important in connection with metals and alloys for service at high temperature.

**CTD (Cold-Worked Twisted & Deformed)/TMT (Thermo Mechanically Treated) Bar & Rods** — Hot rolled round bars/rods with indentations/ribs normally supplied in straight length or in folded bundles. Used directly in civil construction.

**Dead Loads** — The self-weights of all permanent constructions and installations including the self-weight of all walls, partitions, floors, roofs, and other permanent fixtures acting on a member.

**Deflection** — It is the deviation from the standard position of a member or structure.

**Design Life** — Time period for which a structure or a structural element is required to perform its function without damage.

**Design Load/Factored Load** — A load value obtained by multiplying the characteristic load with the partial safety factor for loads.

**Ductility** — Ability to undergo plastic deformation usually as a result of tension.

**Durability** — It is the ability of a material to resist deterioration over long periods of time.

**Earthquake Loads** — The inertia forces produced in a structure due to the ground movement during an earthquake.

**Elastic Deformation** — A reversible change in dimensions under applied stress.

**Elastic Design** — Design, which assumes elastic behavior of materials throughout the service load range.

**Elastic Limit** — The maximum stress (generally in tension) a material can withstand without suffering permanent deformation.

**Elongation** — Increase in the original gauge length at any moment during the test.

**Endurance Limit (Fatigue Limit)** — The maximum stress below which a material can presumably endure an infinite number of stress cycles. If the stress is not completely



reversed, the value of the mean stress, the minimum stress or the stress ratio should be stated. When the mean value of the stress is zero, the endurance limit is equal to half of the maximum range of stress.

**Extension** — Increase in the extensometer gauge length, at any moment during the test.

**Factor of Safety** — The factor by which the yield stress of the material of a member is divided to arrive at the permissible stress in the material.

**Fatigue** — Damage caused by repeated fluctuations of stress, leading to progressive cracking of a structural element.

**Finished Steel** — Products obtained upon hot rolling/forging of Semi-finished steel (blooms/billets/slabs). These cover 2 broad categories of products, namely Long Products and Flat Products.

**Flat Products (Flat Rolled Products)** \_ Finished steel flat products are produced from slabs/thin slabs in rolling mills using flat rolls. These are supplied in hot rolled (HR), cold rolled (CR) or in coated condition depending upon the requirement. Different types of flat products are: plate, sheet, strips, hot rolled (HR) flat products, and cold rolled (CR) strips

**Gauge Length** — Length of the parallel portion of the test piece on which elongation is measured at any moment during the test.

**Hot Rolled (HR) Flat Products** — These are produced by re-rolling of slabs/thin slabs at high temperature (above 1000 degree celsius) in plate mills (which produce plates) or in hot strip mills (which produce strips). Hot rolled strips are cut into straight length to produce HR sheets or thin plates.

**Imposed (Live) Load** — The load assumed to be produced by the intended use or occupancy including distributed, concentrated, impact, vibration and snow loads but excluding, wind, earthquake and temperature loads.

**Lower Yield Strength** — Lowest value of stress during plastic yielding ignoring any initial transient effects.

**Maximum Force** — Highest force that the test piece withstands during the test after the beginning of work-hardening.

**Percentage Elongation** — Elongation expressed as a percentage of the original gauge length.

**Percentage Elongation After Fracture** — Permanent elongation of the gauge length after fracture, expressed as a percentage of the original gauge length.

**Percentage Permanent Elongation** — Increase in the original gauge length of a test piece after removal of a specified stress, expressed as a percentage of the original gauge length.

**Percentage Reduction of Area** — Maximum change in cross-sectional area which has occurred during the test, expressed as a percentage of the original cross-sectional area.

**Permissible Stress** — When a structure is being designed by the working stress method,

the maximum stress that is permitted to be experienced in elements, members or structures under the nominal/service load (action).

**Plastic Design** — Design against the limit state of plastic collapse.

**Plate** — Thick flat finished product of width: + 500 mm and Thickness: (+) 5 mm which are supplied in cut/straight length. Plates are normally produced/supplied in as hot rolled condition with or without specific heat treatments.

**Poisson's Ratio** — It is the absolute value of the ratio of lateral strain to longitudinal strain under uniaxial loading.

**Secondary Member** — Member which is provided for overall stability and or for restraining the main members from buckling or similar modes of failure.

**Shear Force** — The in-plane force at any transverse cross section of a straight member of a column or beam.

**Shear Stress** — The stress component acting parallel to a face, plane or cross section.

**Snow Load** — Load on a structure due to the accumulation of snow and ice on surfaces such as roof.

**Strain** — Deformation caused by stress and expressed as the change per unit of original dimensions in the test bar under tension or compression. Under shear, the strain is measured by the angular displacement. A typical stress-strain curve is given in figure below.

**Strain Hardening** — The phenomenon of increase in stress with increase in strain beyond yielding.

**Strength** — Resistance to failure by yielding or buckling.

**Strength Limit State** — A limit state of collapse or loss of structural integrity.

**Stress** — The internal force per unit area of the original cross section. At any moment during the test, force divided by the original cross-sectional area of the test piece. All references to stress in this document are to engineering stress. A typical stress-strain curve is given in figure below.

**Stress Analysis** — The analysis of the internal force and stress condition in an element, member or structure.

**Stress Rate** — Increase of stress per unit time.

**Stress Relieving (Stabilizing)** — Heating to and, if necessary, holding at a sufficiently high temperature below the transformation range, followed by slow cooling to remove internal stress only. Also called stabilizing treatment.

**Structural Analysis** — The analysis of stress, strain, and deflection characteristics of a structure.

**Tempering** — Heating to elevated temperature but below transformation zone, of hardened steels and holding for specified time at temperatures followed by cooling at desired rate to develop desired mechanical properties in these steels.

**Tensile Strength** — It is stress corresponding to the maximum force. The maximum load reached in a tensile test divided by the original cross-sectional area of the gauge

length portion of the test piece. Also termed as maximum stress or ultimate tensile stress.

**Tensile Stress** — The characteristic stress corresponding to rupture in tension, specified for the grade of steel in the appropriate Indian Standard.

**Tensile Test** — A test in which a standard test piece, gripped at both ends, is subjected to tension by load, which is progressively increased till fracture takes place. This test is conducted to give the following information:

- a) Limit of proportionality;
- b) Yield point;
- c) Proof stress;
- d) Ultimate tensile stress;
- e) Percentage elongation; and
- f) Percentage reduction of area.

**Torsion Test** — A test carried out by twisting a test piece about its axis until fracture occurs. When the test piece is machined off from a bar, the practice is to state the maximum stress in shear and the angle of rotation. In tests for wires, the acting length in relation to the diameter and the number of twists to be withstood, are specified.

**Ultimate Limit State** — The state which, if exceeded can cause collapse of a part or the whole of the structure.

**Upper Yield Strength** — Maximum value of stress prior to the first decrease in force.

**Yield Strength** — When the metallic material exhibits a yield phenomenon, stress corresponding to the point reached during the test at which plastic deformation occurs without any increase in the force.

**Yield Stress** — The characteristic stress of the material in tension before the elastic limit of the material is exceeded, as specified in the appropriate Indian Standard.

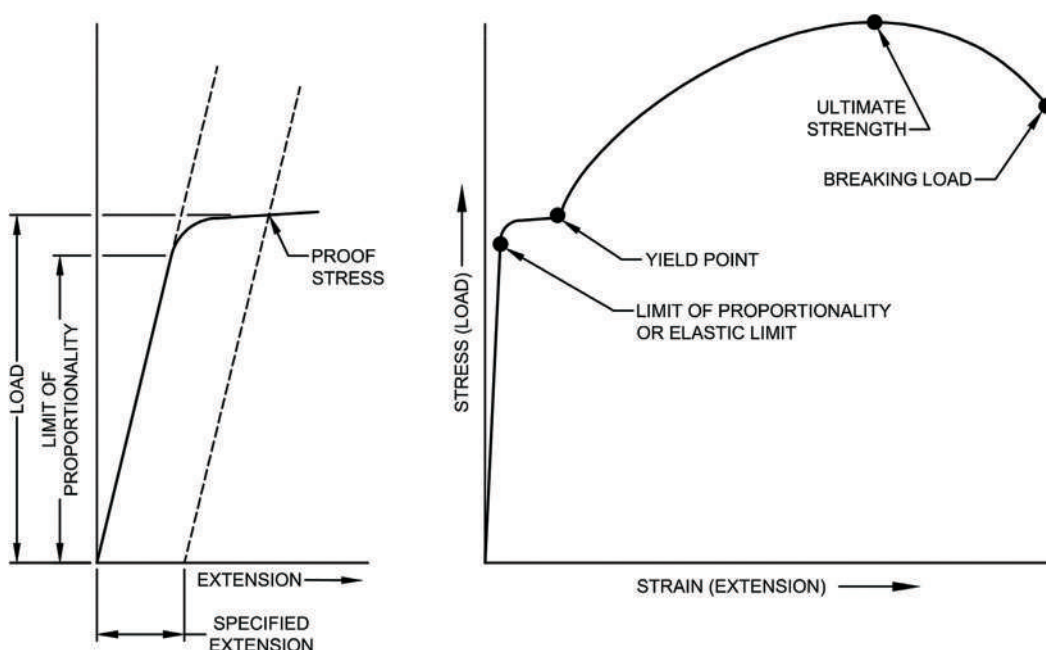

Figure — Stress-Strain Curve



**CHAPTER III**  
**INDIAN STANDARDS ON STEEL**

# CHAPTER III

## INDIAN STANDARDS ON STEEL

### INTRODUCTION

This section covers a brief outline of important Indian Standards on hot rolled and cold rolled structural steel.

### I. HOT ROLLED MEDIUM AND HIGH TENSILE STRUCTURAL STEEL

Indian Standard **IS 2062** covers the requirements of steel including micro-alloyed steel plates, strips, shapes and sections (angles, tees, beams, channels, etc), flats, bars, etc, for use in structural work. The steels are suitable for welded, bolted and riveted structures and for general engineering purposes. Where welding is employed for fabrication and guaranteed-weldability is required, welding procedure should be as specified in **IS 9595**.

### GRADES (see 5)

There are nine grades of steel as given in Tables below. For grades E 250 to E 410, there are four sub-qualities (A, BR, B0 and C) and for grades E 450 to E 650, there are two sub-qualities (A and BR). Sub-qualities A, BR, B0 and C indicate requirement of impact test and mode of de-oxidation as indicated below:

- A : Impact test not required, semi-killed/killed
- BR : Impact test optional; if required at room temperature; semi-killed/killed
- B0 : Impact test mandatory at 0 °C, semi-killed/killed
- C : Impact test mandatory at – 20 °C, killed

### MANUFACTURE (see 6)

Steel may be supplied in semi-killed/killed condition. The steel may be ingot cast or continuously cast.

The processes used in the steel making, casting and further hot rolling into steel plates, strips, sections, flats, bars, etc are left to the discretion of the manufacturer/supplier. If required, secondary refining in the form of ladle refining, vacuum degassing may follow steel making. The products may be rolled and supplied in as-rolled/normalizing/normalizing rolling/controlled rolling/accelerated cooling conditions as per the agreement between the purchaser and the manufacturer/supplier.

Material produced by re-rolling finished products (virgin or used or scrap), or by rolling material for which the metallurgical history is not fully documented or not known, are not acceptable as per this standard.

### Chemical Composition

Grade Designation	Quality	Ladle Analysis, Percent, <i>Max</i>					Carbon Equivalent (CE), <i>Max</i>	Mode of Deoxidation
		C	Mn	S	P	Si		
(1)	(2)	(3)	(4)	(5)	(6)	(7)	(8)	(9)
E 250	<b>A</b>	0.23	1.50	0.045	0.045	0.40	0.42	Semi-killed/killed
	<b>BR BO</b>	0.22	1.50	0.045	0.045	0.40	0.41	Semi-killed/killed
	<b>C</b>	0.20	1.50	0.040	0.040	0.40	0.39	Killed
E 275	<b>A</b>	0.23	1.50	0.045	0.045	0.40	0.43	Semi-killed/killed
	<b>BR BO</b>	0.22	1.50	0.045	0.045	0.40	0.42	Semi-killed/killed
	<b>C</b>	0.20	1.50	0.040	0.040	0.40	0.41	Killed
E 300	<b>A BR BO</b>	0.20	1.50	0.045	0.045	0.45	0.44	Semi-killed/killed
	<b>C</b>	0.20	1.50	0.040	0.040	0.45	0.44	Killed
E 350	<b>A BR BO</b>	0.20	1.55	0.045	0.045	0.45	0.47	Semi-killed/killed
	<b>C</b>	0.20	1.55	0.040	0.040	0.45	0.45	Killed
E 410	<b>A BR BO</b>	0.20	1.60	0.045	0.045	0.45	0.50	Semi-killed/killed
	<b>C</b>	0.20	1.60	0.040	0.040	0.45	0.50	Killed
E 450	<b>A</b>	0.22	1.65	0.045	0.045	0.45	0.52	Semi-killed/killed
	<b>BR</b>							
E 550	<b>A</b>	0.22	1.65	0.020	0.025	0.50	0.54	Semi-killed/killed
	<b>BR</b>							
E 600	<b>A</b>	0.22	1.70	0.020	0.025	0.50	0.54	Semi-killed/killed
	<b>BR</b>							
E 650	<b>A</b>	0.22	1.70	0.015	0.025	0.50	0.55	Semi-killed/killed
	<b>BR</b>							

#### NOTES

- 1** Grade designation system is based on minimum yield stress.
- 2** For semi-killed steel, silicon shall be less than 0.10 percent. For killed steel, when the steel is killed by aluminium alone, the total aluminium content shall not be less than 0.02 percent. When the steel is killed by silicon alone,

the silicon content shall not be less than 0.10 percent. When the steel is silicon-aluminium killed, the silicon content shall not be less than 0.03 percent and total aluminium content shall not be less than 0.01 percent.

**3** Steels of qualities A, BR, B0 and C are generally suitable for welding processes. The weldability increases from quality A to C for grade designation E 250 and E 275.

**4** Carbon equivalent (CE) would be calculated based on ladle analysis, only.

$$CE=C+\frac{Mn}{6}+\frac{(Cr+Mo+V)}{5}+\frac{(Ni+Cu)}{15}$$

**5** Micro-alloying elements like Nb, V and Ti may be added singly or in combination. Total micro-alloying elements shall not be more than 0.25 percent.

**6** Alloying elements such as Cr, Ni, Mo and B may be added under agreement between the purchaser and the manufacturer. In case of E 600 and E 650 the limit of Cr and Ni, either singly or in combination, shall not exceed 0.50 percent and 0.60 percent respectively.

**7** Copper may be present between 0.20 to 0.35 percent as mutually agreed to between the purchaser and the manufacturer. The copper bearing quality shall be designated with a suffix Cu, for example E 250 Cu. In case of product analysis the copper content shall be between 0.17 and 0.38 percent.

Grade Designation	Quality	Ladle Analysis, Percent,					Carbon Equivalent (CE), Max	Mode of Deoxidation
		Max						
		C	Mn	S	P	Si		
(1)	(2)	(3)	(4)	(5)	(6)	(7)	(8)	(9)

**8** Incidental element — Elements not quoted in table shall not be intentionally added to steel without the agreement of the purchaser, other than for the purpose of finishing the heat. All reasonable precautions shall be taken to prevent the addition from scrap or other materials used in manufacture of such elements which affect the hardenability, mechanical properties and applicability.

**9** Nitrogen content of steel shall not exceed 0.012 percent which shall be ensured by the manufacturer by occasional check analysis.

**10** The steel, if required, may be treated with calcium based compound or rare earth element for better formability.

**11** Lower limits for carbon equivalent and closer limits for other elements may be mutually agreed to between the purchaser and the manufacturer.

### Mechanical Properties

Grade Designation	Quality	Tensile Strength <i>R<sub>m</sub></i> , <i>Min</i> MPa (see Note 1)	Yield Stress <i>ReH</i> , <i>Min</i> MPa <sup>1)</sup>			Percentage Elongation <i>A</i> , <i>Min</i> at Gauge Length, <i>L<sub>0</sub></i> = 5.65	Internal Bend Diameter, <i>Min</i> (see Note 2)		Charpy Impact Test (see Note 3)	
			< 20	20-40	> 40		< 25	> 25	Temp	Min J
(1)	(2)	(3)	(4)	(5)	(6)	(7)	(8)	(9)	(10)	(11)
E250	<b>A</b>	410	250	240	230	23	2 <i>t</i>	3 <i>t</i>	—	—
	<b>BR</b>								RT	27
	<b>B0</b>								0	27
	<b>C</b>								(-20)	27
E275	<b>A</b>	430	275	265	255	22	2 <i>t</i>	3 <i>t</i>	—	—
	<b>BR</b>								RT	27
	<b>B0</b>								0	27
	<b>C</b>								(-20)	27
E300	<b>A</b>	440	300	290	280	22	2 <i>t</i>	—	—	—
	<b>BR</b>								RT	27
	<b>B0</b>								0	27
	<b>C</b>								(-20)	27
E350	<b>A</b>	490	350	330	320	22	2 <i>t</i>	—	—	—
	<b>BR</b>								RT	27
	<b>B0</b>								0	27
	<b>C</b>								(-20)	27
E410	<b>A</b>	540	410	390	380	20	2 <i>t</i>	—	—	—
	<b>BR</b>								RT	25
	<b>B0</b>								0	25
	<b>C</b>								(-20)	25
E450	<b>A</b>	570	450	430	420	20	2.5 <i>t</i>	—	—	—
	<b>BR</b>								RT	20
E550	<b>A</b>	650	550	530	520	12	3 <i>t</i>	—	—	—
	<b>BR</b>								RT	15
E600	<b>A</b>	730	600	580	570	12	3.5 <i>t</i>	—	—	—
	<b>BR</b>								RT	15
E650	<b>A</b>	780	650	630	620	12	4 <i>t</i>	—	—	—
	<b>BR</b>								RT	15

**NOTES**

**1** In case of product thickness/diameter more than 100 mm, lower minimum



limit of tensile strength may be mutually agreed to between the purchaser and the manufacturer/supplier.

- 2** Bend test not required for thickness > 25 mm for grades E 300 to E 650. 't' is the thickness of the test piece.
- 3** For sub-quality BR, impact test is optional; if required, at room temperature (25 °C ± 2 °C).

## II. COLD REDUCED CARBON STEEL SHEET AND STRIP

Indian standard **IS 513 (Part 1)** covers the requirements of cold reduced carbon steel sheets and strips for cold forming and drawing purpose and where the surface is of prime importance. It covers sheets and strips up to 4.0 mm thick both in coil form and cut lengths.

This standard is published in two parts. The other part in the series is: Part 2 High tensile and multi-phase steel.

### Designation and Grades

Designation(Quality)	Grade	Available Product Range, mm
(1)	(2)	(3)
Cold rolled (full hard)	CR0	0.08 - 4.00
General purpose	CR1	0.08 - 4.00
	CR2	0.20 - 4.00
	CR3	0.20 - 4.00
	CR4	0.30 - 4.00
	CR5	0.30 - 4.00
Drawing quality	ISC270C	0.20 - 3.20
	ISC270D	0.20 - 3.20
	ISC270E	0.20 - 3.20
	ISC270F	0.40 - 3.20
	ISC260G	0.40 - 2.30
Interstitial free-high strength steel	ISC340P	0.40 - 2.30
	ISC370P	0.40 - 2.30
	ISC390P	0.40 - 2.30
	ISC440P	0.40 - 2.30
Bake hardening	ISC270B	0.40 - 2.30
	ISC300B	0.40 - 2.30
	ISC320B	0.40 - 2.30
	ISC340B	0.40 - 2.30
	ISC360B	0.40 - 2.30
	ISC390B	0.40 - 2.30
	ISC440B	0.40 - 2.30

Re-phosphorized	ISC280R	0.40 - 3.00
	ISC320R	0.40 - 3.00
	ISC360R	0.40 - 3.00
	ISC400R	0.40 - 3.00
C, Mn steel	ISC340W	0.40 - 3.00
	ISC370W	0.40 - 3.00
	ISC390W	0.40 - 3.00
	ISC440W	0.40 - 3.00
NOTES		
<b>1</b>	For any thickness greater than or less than the mentioned range, the same can be produced as mutually agreed to between the manufacturer and the purchaser. Acceptance criteria for the range out of available product range shall be as agreed to between the purchaser and the manufacturer.	
<b>2</b>	For general purpose designation, grade qualities areas follows CR1 — Commercial, CR2 — Drawing, CR3 — Deep drawing, CR4 — Extra deep drawing, CR5 — Extra deep drawing (stabilized interstitial free).	

### III. COLD-FORMED LIGHT GAUGE STEEL STRUCTURAL MEMBERS IN GENERAL BUILDING CONSTRUCTION

Indian Standard **IS 801** covers the design of structural members cold-formed to shape from carbon or low-alloy, sheet or strip steels used for load carrying purposes in buildings. It may also be used for structures other than buildings provided appropriate allowances are made for dynamic effects.

Cold-formed steel structural members are cold-formed in rolls or press brakes from flat steel, generally not thicker than 12.5 mm. For repetitive mass production they are formed most economically by cold-rolling, while smaller quantities of special shapes are most economically produced on press brakes. The latter process, with its great versatility of shape variation, makes this type of construction as adaptable to special requirements as reinforced concrete is in its field of use. Members are connected by spot, fillet, plug or slot welds, by screw, bolts, cold rivets or any other special devices. This type of construction is appropriate and economical under one or more of the following conditions:

- a) Where moderate loads and spans make the thicker, hot-rolled shapes uneconomical.  
Example — joists, purlins, girts, roof, trusses, complete framing for one- and two-storey residential, commercial and industrial structures;
- b) Where it is desired that load-carrying members also provide useful surfaces.  
Example — door panels and roof decks, mostly installed without any shoring and wall panels; and
- c) Where sub-assemblies of such members can be prefabricated in the plant, reducing site erection to a minimum of simple operations.

Example — sub-assembly of panel framing up to 3 m × 4 m and more for structures listed in standardized package shed-type utility buildings, etc.

#### IV. STEEL TUBES IN GENERAL BUILDING CONSTRUCTION

Indian Standard **IS 806** deals with the use of structural steel tubes in general building construction and is complementary to **IS 800**. Provisions which are of special application to construction using steel tubes are included in this code.

The use of tubular steel in structural work would result in considerable savings, particularly in the case of roof trusses, latticed girders and compression members.

Grades YSt 22, YSt 25 and YSt 32 of steel tubes mentioned in this standard are covered in IS 1161.

#### **MATERIALS** (see 3)

##### **Steel Tubes**

Steel tubes used in building construction shall be hot finished tubes conforming to the requirements specified in **IS 1161**.

Tubes made by other than hot finishing processes, or which have been subjected to cold working, shall be regarded as hot finished if they have subsequently been heat-treated and are supplied in the normalized conditions.

#### V. HOT ROLLED CARBON STEEL SHEET, PLATE AND STRIP

Indian Standard **IS 1079** covers the requirements for hot rolled low carbon steel sheets, plates and strips intended for drawing and forming for automobile and general engineering purposes.

#### **DESIGNATION AND GRADES** (see 5)

There are 8 grades of hot rolled carbon steel sheet and strip designated as given below:

##### **Designation and Grades**

Sl No.	Grade	Designation (Quality)
(1)	(2)	(3)
i)	HR0	Ordinary
ii)	HR1	Commercial quality intended for general fabrication purposes where sheets, or strips are used in the flat or for bending, moderate forming and welding operations
iii)	HR2	General purpose
iv)	HR3	
v)	HR4	
vi)	ISH270C	Drawing quality
vii)	ISH270D	
viii)	ISH270E	

Nomenclature for designation and grades is as follows:

IS H 270 C

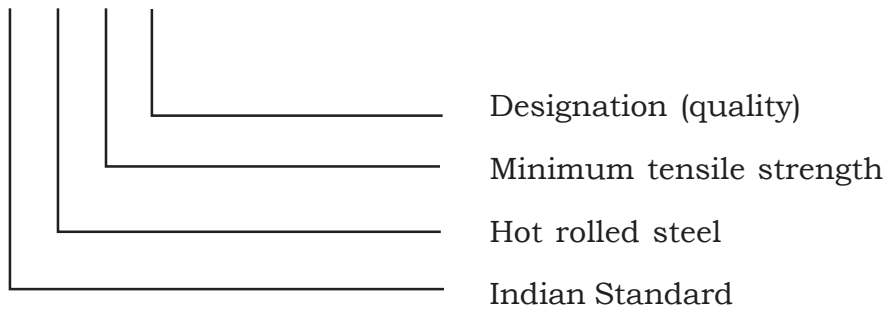

Steel sheets, plates and strips shall be supplied in the rimmed, semi-killed or killed condition as agreed to between the purchaser and the manufacturer. However, HR3, HR4, ISH270D and ISH270E shall be supplied in killed condition only.



# **CHAPTER IV**

## **IMPORTANT TEST METHODS**

# CHAPTER IV

## IMPORTANT TEST METHODS

### INTRODUCTION

This section covers a brief outline of important Indian Standards on test methods for structural steels. This section covers important aspects of tensile test, bend test, impact test, and hardness test.

### I. TENSILE TEST

Indian Standard **IS 1608 (Part 1)** specifies the method for tensile testing of metallic materials and defines the mechanical properties which can be determined at room temperature.

#### **PRINCIPLE** (see 5)

The test involves straining a test piece by tensile force, generally to fracture, for the determination of one or more of the mechanical properties.

The test shall be carried out at room temperature between 10 °C and 35 °C, unless otherwise specified.

Tests carried out under controlled conditions shall be made at a temperature of 23 °C ± 5 °C.

### TEST EQUIPMENT

The testing machine shall apply a force along the axis of the test piece while keeping inadvertent bending or torsion of the test piece to a minimum. The force shall be applied to the test piece without shock.

#### **TEST PIECES** (see 6)

##### **Shape and Dimensions**

###### *General*

The shape and dimensions of the test pieces may be constrained by the shape and dimensions of the metallic product from which the test pieces are taken.

The test piece is usually obtained by machining a sample from the product or a pressed blank or casting. However, products of uniform cross-section (sections, bars, wires, etc) and also as-cast test pieces (i.e. for cast iron and nonferrous alloys) may be tested without being machined. The cross-section of the test pieces may be circular, square, rectangular, annular or, in special cases, some other uniform cross-section.

Preferred test pieces have a direct relationship between the original gauge length,  $L_0$ , and the original cross-sectional area,  $S_0$ , expressed by the formula  $L_0 = k\sqrt{S_0}$ , where  $k$  is a coefficient of proportionality, and are called proportional test pieces. The internationally adopted value for  $k$  is 5.65. The original gauge length shall be not less than 15 mm. When the cross-sectional area of the test piece is too small for this requirement to be met with  $k = 5.65$ , a higher value (preferably 11.3) or a non-proportional test piece may be used.

NOTE — By using an original gauge length smaller than 20 mm, the uncertainty of the result “elongation after fracture” will be increased.



For non-proportional test pieces, the original gauge length,  $L_0$ , is independent of the original cross-sectional area,  $S_0$ . The dimensional tolerances of the test pieces shall be as specified in the standard.

Types (see 6.2)

The main types of test pieces are defined according to the shape and type of product, as shown in the table given below.

### Main Types of Test Pieces According to Product Type

Dimensions in millimetres.

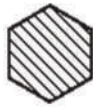
Type of product	
Sheets — Plates — Flats	Wire — Bars — Sections
	  
<b>Thickness <math>a</math></b>	<b>Diameter or side</b>
$0.1 < a < 3$	—
—	$< 4$
$a < 3$	$> 4$

### DETERMINATION OF PROPERTIES

#### Determination of the Upper Yield Strength ( $R_{eH}$ ) (see 11)

$R_{eH}$  may be determined from the force-extension curve or peak load indicator and is defined as the maximum value of stress prior to the first decrease in force. The value is calculated by dividing this force by the original cross-sectional area of the test piece,  $S_0$ .

#### Determination of the Lower Yield Strength ( $R_{eL}$ ) (see 12)

$R_{eL}$  is determined from the force-extension curve and is defined as the lowest value of stress during plastic yielding, ignoring any initial transient effects. The value is calculated by dividing this force by the original cross-sectional area of the test piece,  $S_0$ .

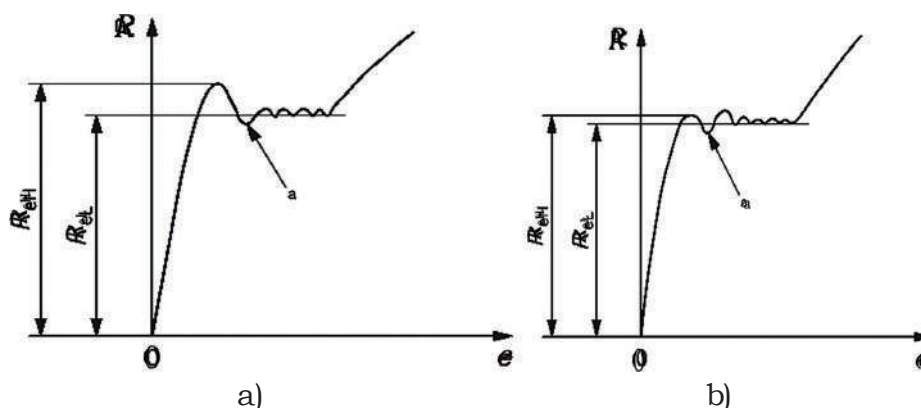

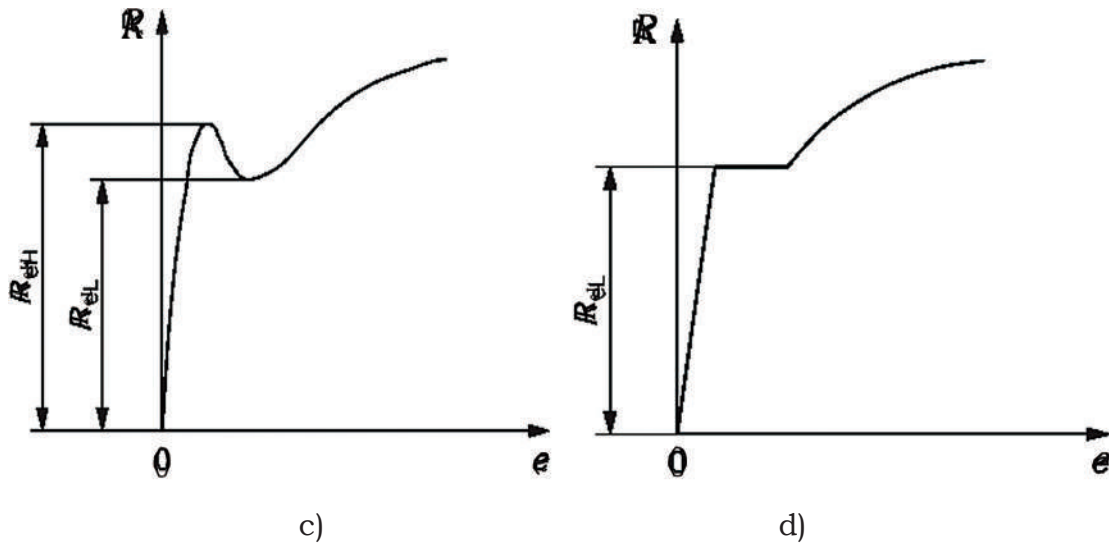

Key

$e$  percentage extension       $R$  stress  
 $ReH$  upper yield strength       $ReL$  lower yield strength  
 $a$  initial transient effect.

Figure — Examples of Upper And Lower Yield Strengths for Different Types of Curve

**Proof Strength, Plastic Extension ( $R_p$ ) (see 13)**

$R_p$  is determined from the force-extension curve by drawing a line parallel to the linear portion of the curve and at a distance from it equivalent to the prescribed plastic percentage extension, example, 0.2 %. The point at which this line intersects the curve gives the force corresponding to the desired proof strength plastic extension. The latter is obtained by dividing this force by the original cross-sectional area of the test piece, So (see Figure below).

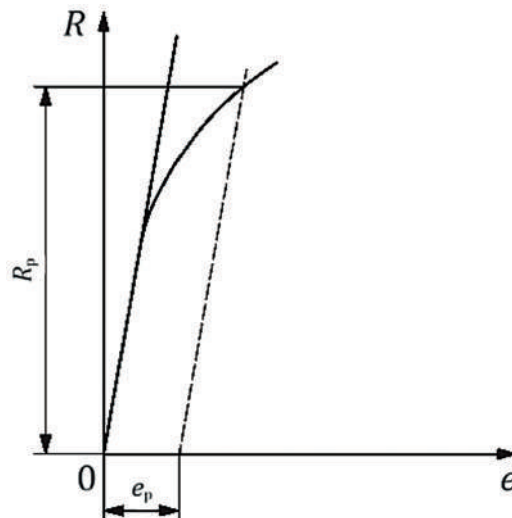

Key

$e$  percentage extension       $R$  stress  
 $R_p$  proof strength, plastic extension       $e_p$  specified percentage plastic extension

Figure — Proof Strength, Plastic Extension,  $R_p$



### Proof Strength, Total Extension ( $R_t$ ) (see 14)

$R_t$  is determined on the force-extension curve, by drawing a line parallel to the ordinate axis (force axis) and at a distance from this equivalent to the prescribed total percentage extension. The point at which this line intersects the curve gives the force corresponding to the desired proof strength. The value is calculated by dividing this force by the original cross-sectional area of the test piece, So (see Figure below).

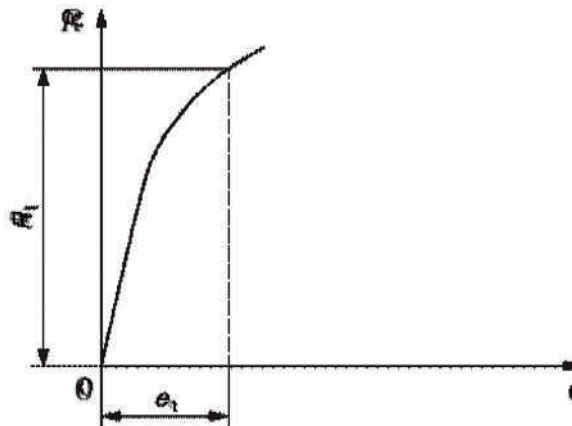

#### Key

$e$	percentage extension	$R$	stress
$e_t$	percentage total extension	$R_t$	proof strength, total extension

Figure — Proof Strength, Total Extension,  $R_t$

### Percentage Yield Point Extension ( $A_e$ ) (see 16)

For materials that exhibit discontinuous yielding,  $A_e$  is determined from the force-extension curve by subtracting the extension at  $R_{eH}$  from the extension at the start of uniform work-hardening. The extension at the start of uniform work-hardening is defined by the intersection of a horizontal line through the last local minimum point, or a regression line through the range of yielding, prior to uniform work-hardening and a line corresponding to the highest slope of the curve occurring at the start of uniform work-hardening (see Figure below). It is expressed as a percentage of the extensometer gauge length,  $L_e$ .

### Percentage Plastic Extension at Maximum Force ( $A_g$ ) (see 17)

The method consists of determining the extension at maximum force on the force-extension curve obtained with an extensometer and subtracting the elastic strain.

Calculate the percentage plastic extension at maximum force,  $A_g$ , from formula:

$$A_g = \left[ \frac{\Delta L_m}{L_e} - \frac{R_m}{mE} \right] \times 100$$

where

$\Delta L_m$  is the extension at maximum force;

$L_e$  is the extensometer gauge length;

$R_m$  is the tensile strength; and

$mE$  is the slope of the elastic part of the stress-percentage extension curve.

### Percentage Total Extension at Maximum Force ( $A_{gt}$ ) (see 18)

The method consists of determining the extension at maximum force on the force-extension curve obtained with an extensometer. Calculate the percentage total extension at maximum force,  $A_{gt}$ , from formula:

$$A_g = \frac{\Delta L_m}{L_e} \times 100$$

where

$\Delta L_m$  is the extension at maximum force; and

$L_e$  is the extensometer gauge length.

NOTE — For materials which exhibit a plateau at maximum force, the percentage total extension at maximum force is the extension at the mid-point of the plateau (see Figure below).

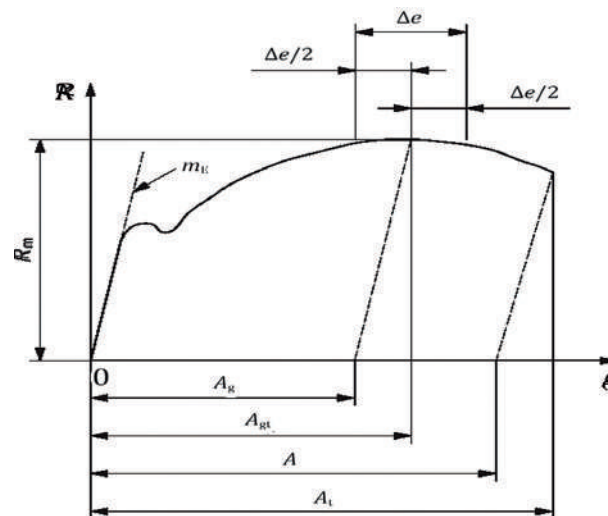

#### Key

- A percentage elongation after fracture determined from the extensometer signal or directly from the test piece
- $A_g$  percentage plastic extension at maximum force  $A_{gt}$  percentage total extension at maximum force  $A_t$  percentage total extension at fracture
- $e$  percentage extension
- $mE$  slope of the elastic part of the stress-percentage extension curve
- $R$  stress
- $R_m$  tensile strength
- $\Delta e$  plateau extent (for determination of  $A_g$ )

**Figure — Definitions of Extension**

### Percentage Total Extension at Fracture ( $A_t$ ) (see 19)

The method consists of determining the extension at fracture on the force-extension curve obtained with an extensometer.

Calculate the percentage total elongation at fracture,  $A_t$ , from formula:

$$A_t = \frac{\Delta L_f}{L_e} \times 100$$

where

$\Delta L_f$  is the extension at fracture; and

$L_e$  is the extensometer gauge length.

### **Percentage Elongation after Fracture (A) (see 20)**

For this purpose, the broken pieces of the test piece shall be carefully fitted back together so that their axes lie in a straight line.

Special precautions shall be taken to ensure proper contact between the broken parts of the test piece when measuring the final gauge length. This is particularly important for test pieces of small cross-section and test pieces having low elongation values.

### **Calculate the percentage elongation after fracture, A, from formula:**

$$A = \frac{L_u - L_o}{L_o} \times 100$$

where

$L_u$  is the final gauge length after fracture;

and  $L_o$  is the original gauge length.

Elongation after fracture,  $L_u - L_o$ , shall be determined to the nearest 0.25 mm or better using a measuring device with sufficient resolution.

The result of this determination is valid only if fracture and localized extension (necking) occur within the extensometer gauge length,  $L_e$ . The percentage elongation after fracture can be regarded as valid regardless of the position of the fracture cross-section if the percentage elongation after fracture is equal to or greater than the specified value. If the product standard specifies the determination of percentage elongation after fracture for a given gauge length, the extensometer gauge length should be equal to this length.

If elongation is measured over a given fixed length, it can be converted to proportional gauge length, using conversion formulae or tables as agreed before the commencement of testing.

NOTE — Comparisons of percentage elongation are possible only when the gauge length or extensometer gauge length, the shape, and cross-sectional area are the same or when the coefficient of proportionality,  $k$ , is the same.

### **Percentage Reduction of Area (see 21)**

Percentage reduction of area,  $Z$ , can be calculated from the formula given below:

$$Z = \frac{S_u - S_u}{S_o} \times 100$$

where

$S_o$  = original cross-sectional area of the parallel length; and

$S_u$  = minimum cross-sectional area after fracture.

## II. BEND TEST

Indian Standard **IS 1599** specifies a method for determining the ability of metallic materials to undergo plastic deformation in bending. It applies to test pieces taken from metallic products, as specified in the relevant product standard. It is not applicable to certain materials or products, for example tubes in full section or welded joints, for which other standards exist.

### PRINCIPLE (see 5)

The bend test consists of submitting a test piece of round, square, rectangular or polygonal cross-section to plastic deformation by bending, without changing the direction of loading, until a specified angle of bend is reached.

The axes of two legs of the test piece remain in a plane perpendicular to the axis of bending. In the case of a 180° bend, the two lateral surfaces may, depending on the requirements of the product standard, lie flat against each other or can be parallel at a specified distance, an insert being used to control this distance.

### TEST EQUIPMENT (see 6)

#### General

The bend test shall be carried out in testing machines or presses equipped with the following devices:

- bending device with two supports and a former as shown in figure;
- bending device with a V-block and a former as shown in figure; and
- bending device with a clamp as shown in figure.

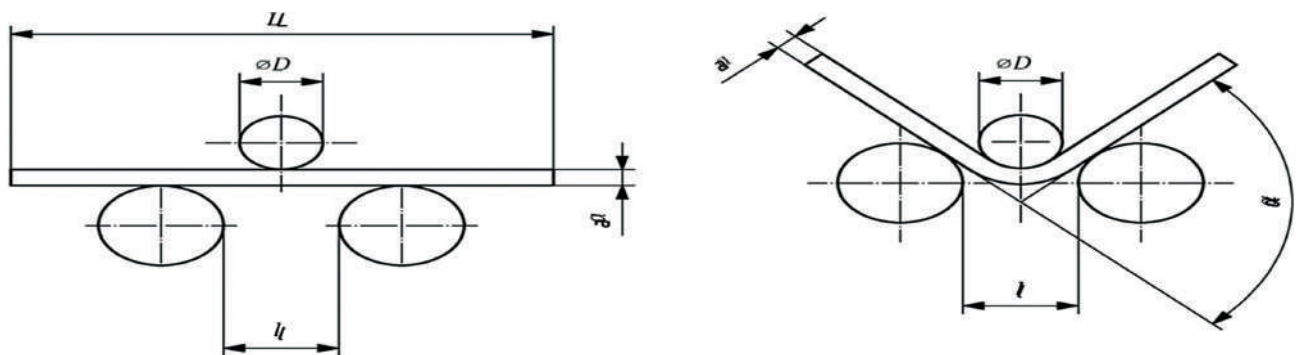

Figure — Bending Device with Two Supports and a Former

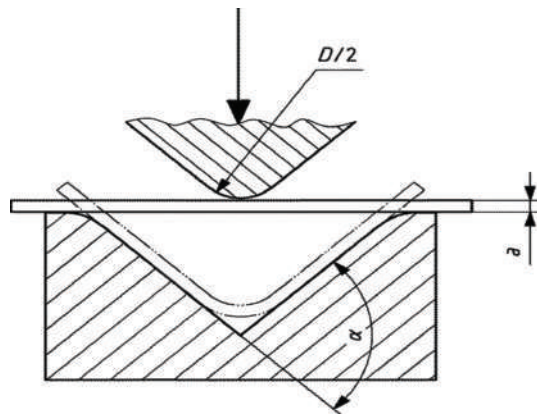
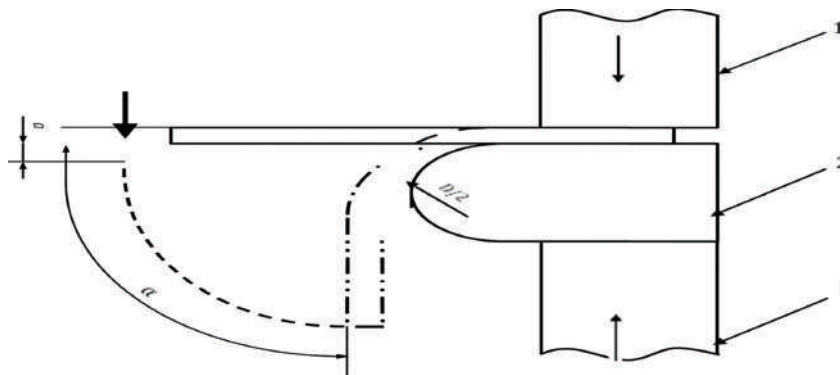

Figure — Bending Device with a V-block and a Former



**Key**

1 clamp      2 former

Figure — Bending Device with a Clamp

**TEST PIECES** (see 7)

Round, square, rectangular or polygonal cross-section test pieces shall be used in the test. The test piece shall be prepared as per 7 of **IS 1599 : 2023**.

**PROCEDURE** (see 8)

In general, tests are carried out at ambient temperature between 10 °C and 35 °C. Tests carried out under controlled conditions, where required, shall be made at a temperature of (23 ± 5) °C.

The bend test shall be carried out using one of the following methods as specified in the relevant standard:

- a) a specified angle of bend is achieved under an appropriate force and for the given conditions;
- b) the legs of the test piece are parallel to each other at a specified distance apart while under an appropriate force); and
- c) the legs of the test piece are in direct contact while under an appropriate force.

NOTE — See below Fig. for illustration.

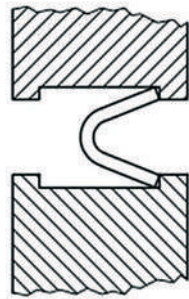

*Figure — Bending the Legs of the Test Piece*

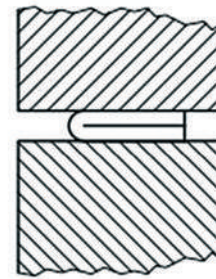

*Figure — Legs of the Test Piece in Direct Contact*

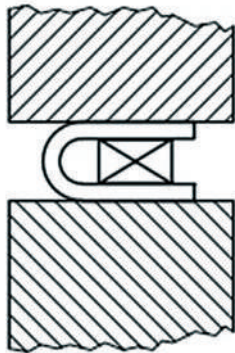

*Figure — Legs of the Test Piece Parallel to Each Other*



### III. IMPACT TEST

#### CHARPY TEST

Indian Standard **IS 1757 (Part 1)** covers the Charpy (V-notch and U-notch) pendulum impact test method for determining the energy absorbed in an impact test of metallic materials. It does not cover instrumented impact testing.

#### Principle

This test consists of breaking a notched test piece with a single blow from a swinging pendulum. The notch in the test piece has a specified geometry and is located in the middle between two supports, opposite to the location which is impacted in the test. The energy absorbed in the impact test, the lateral expansion and the shear fracture appearance are normally determined.

Because the impact values of many metallic materials vary with temperature, tests shall be carried out at a specified temperature. When this temperature is other than ambient, the test piece shall be heated or cooled to that temperature, under controlled conditions.

The Charpy pendulum impact test is often used in routine, high-throughput pass/fail acceptance tests in industrial settings. For these tests, it may not be important whether the test sample is completely broken, partially broken, or simply plastically deformed and dragged through the anvils. In research, design, or academic settings, the measured energy values are studied in more detail, in which case it can be highly relevant whether the sample is broken or not.

It is important to note that not all Charpy pendulum impact test results can be directly compared. For example, the test can be performed with hammers having strikers with

different radii, or with different test piece shapes. Tests performed with different strikers can give different results, and test results obtained with differently shaped test pieces can as well.

### IZOD IMPACT TEST

Indian Standard **IS 1598** prescribes the method of conducting izod impact test on metals.

Principle (see 2)

The test consists of breaking by one blow from a swinging hammer, under specified conditions, a notched test piece, gripped vertically with the bottom of the notch in the same plane as the upper face of the grips. The blow is struck at a fixed position on the face having the notch. The energy absorbed shall determined as per the standard.

## IV. HARDNESS TEST

### BRINELL HARDNESS TEST

Indian Standard **IS 1500 (Part 1)** covers the method for the Brinell hardness test for metallic materials. It is applicable to both fixed location and portable hardness testing machines.

Principle (see 3)

An indenter (tungsten carbide composite ball with diameter,  $D$ ) is forced into the surface of a test piece and, after removal of the force,  $F$ , the diameter of the indentation,  $d$ , left in the surface is measured as shown in Fig. below.

The Brinell hardness is proportional to the quotient obtained by dividing the test force by the curved surface area of the indentation. The indentation is assumed to take the shape of the unloaded ball indenter, and its surface area is calculated from the mean indentation diameter and the ball diameter.

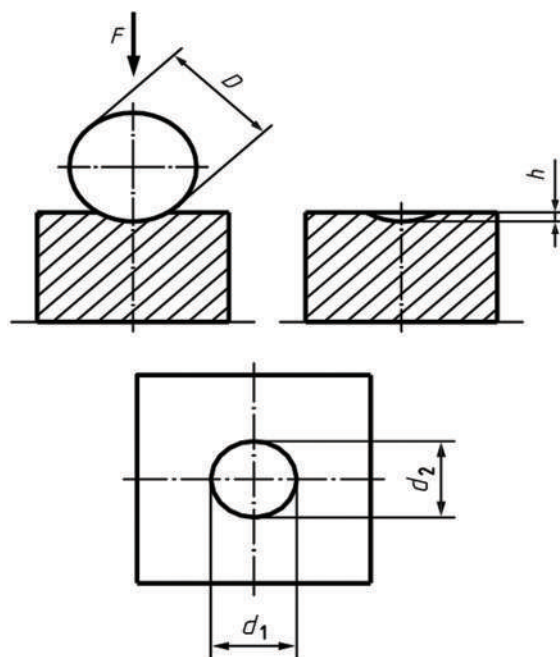

Figure — Principle of Test

## Test Equipment (see 5)

*Testing Machine* — capable of applying a predetermined test force or test forces within the range of 9.807 N to 29.42 kN, in accordance with IS 1500 (Part 2).

*Indenter* — a polished tungsten carbide composite ball, as specified in IS 1500 (Part 2).

*Indentation Diameter Measuring System* — as specified in IS 1500 (Part 2).

## Procedure (see 7)

In general, the test should be carried out at ambient temperature within the limits of 10 °C to 35 °C. However, because temperature variation can affect the results, users of the Brinell test can choose to control the temperature within a tighter range, such as 23 °C ± 5 °C.

The test forces given in below shall be used. Other test forces and force-diameter indices can be used by special agreement.

## VICKERS HARDNESS TEST

Indian Standard IS 12783 specifies the method of conducting Vickers hardness test for hard metals.

### Principle (see 3)

A diamond indenter in the form of a right pyramid with a square base and a specified angle  $\alpha$  between opposite faces at the vertex, is forced into the surface of the hard metal test piece under the test force  $F$  (see Fig. below). The diagonal  $d$  of the indentation left in the surface, after removal of the test force  $F$ , is measured (see Fig. below).

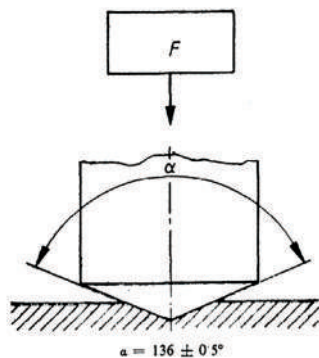

Figure — Indenter (Diamond Pyramid)

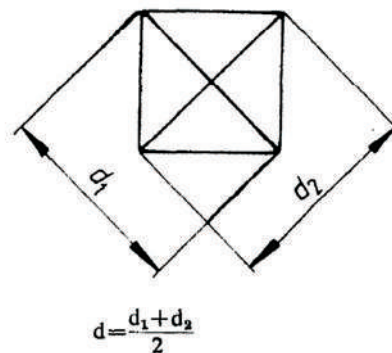

Figure — Vickers Indentation

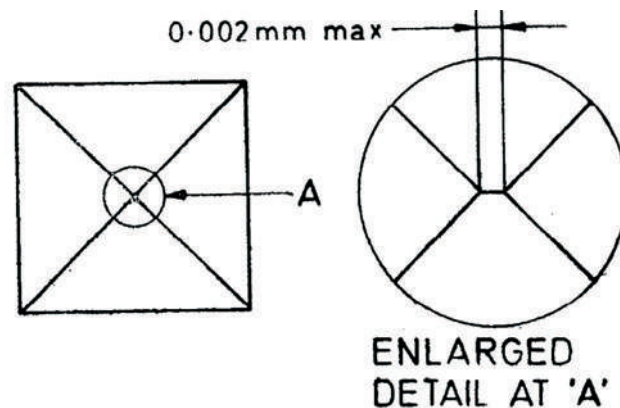

Figure — Indenter Point (Magnified)



The Vickers hardness is proportional to the quotient obtained by dividing the test force by the sloping area of the indentation which is assumed to be a right pyramid with a square base and having at the vertex the same angle as the indenter.

### **Testing Equipment (see 5)**

*Testing Machine* — capable of applying a predetermined force(s) within the range of 9.807 N to 490.3 N (HV 1 to HV 50) in accordance with **IS 1754 (Part 1) : 1986**.

*Indenter* — consists of a diamond in the form of a right pyramid with square base. The angle at the vertex between opposite faces of the indenter is  $136^\circ \pm 0.5^\circ$ .

Four faces of the indenter are equally inclined to the axis of the indenter and meet in a point, that is any line of junction between opposite faces is less than 0.002 mm in length. A common form of point when examined under high magnification is shown in figure above.

*Measuring Device* — capable of measuring indentation diagonals to the following accuracy:

$d < 100 \mu\text{m} : \pm 0.2 \mu\text{m}$

$100 \mu\text{m} < d < 200 \mu\text{m} : \pm 1.0 \mu\text{m}$

$d > 200 \mu\text{m} : \pm 5 \text{ percent.}$

### **ROCKWELL HARDNESS TEST**

Indian Standard **IS 1586 (Part 1)** specifies the method for Rockwell regular and Rockwell superficial hardness tests for scales A, B, C, D, E, F, G, H, K, 15 N, 30 N, 45 N, 15 T, 30 T, and 45 T for metallic materials and is applicable to stationary and portable hardness testing machines.

For specific materials and/or products, other specific Indian Standards apply.

### **Principle (see 3)**

An indenter of specified size, shape, and material is forced into the surface of a test specimen under two force levels using the specific conditions. The specified preliminary force is applied and the initial indentation depth is measured, followed by the application and removal of a specified additional force, returning to the preliminary force. The final indentation depth is then measured and the Rockwell hardness value is derived from the difference,  $h$ , in the final and initial indentation depths and the two constants  $N$  and  $S$  as shown in formula.

$$\text{Rockwell hardness} = N - \frac{h}{S}$$

### **Testing Equipment (see 5)**

*Testing Machine* — shall be capable of applying the test forces for some or all of the Rockwell hardness scales, performing the procedure and complying with all of the requirements defined in IS 1586 (Part 2).

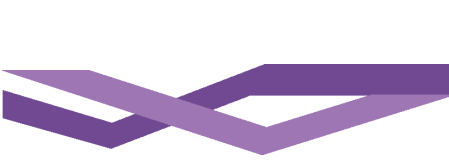

*Sphericoconical Diamond Indenter* — shall be in accordance with IS 1586 (Part 2), with an included angle of  $120^\circ$  and radius of curvature at the tip of 0.2 mm. Diamond indenters shall be certified for use for either:

- a) only the regular Rockwell diamond scales,
- b) only the superficial Rockwell diamond scales, or
- c) both the regular and the superficial Rockwell diamond scales.

*Ball Indenter* — shall be tungsten carbide composite in accordance with IS 1586 (Part 1), with a diameter of 1.587 5 mm or 3.175 mm.



**CHAPTER V**  
**LOADS, FORCES AND EFFECTS**

# CHAPTER V

## LOADS, FORCES AND EFFECTS

### I. INTRODUCTION

This section covers design loads [including, dead loads, imposed loads, wind loads, snow load on roof(s), special loads, seismic loads, load combination, and multi-hazard risk in various districts of India] for buildings and structures.

Indian Standard **IS 875** serves as a guide for civil engineers, designers, and architects involved in the planning and design of buildings. Specifically, it includes provisions for establishing the basic design loads that need to be assumed during the design process.

Buildings are vital structures that fulfill numerous functions essential for human activities, safety, and comfort. These functions include:

1. **Utility for Intended Use and Occupancy:** Buildings must be designed to fulfill their intended purpose, whether it's residential, commercial, industrial, or institutional. The layout, features, and amenities should meet the needs of occupants and facilitate their activities.
2. **Structural Safety:** Ensuring that buildings can withstand various loads and forces without failure is crucial for structural safety. This involves considering factors such as dead loads (permanent weights of the structure), imposed loads (temporary loads like furniture and people), snow loads, and other external loads.
3. **Fire Safety:** Buildings must be designed to minimize the risk of fire occurrence and to facilitate safe evacuation in case of emergencies. This includes proper fire-rated construction materials, adequate fire suppression systems, and clear escape routes.
4. **Compliance with Hygienic, Sanitation, Ventilation, and Daylight Standards:** Buildings should provide a healthy and comfortable environment for occupants. This entails adherence to standards for cleanliness, sanitation, ventilation, and access to natural light to promote well-being and productivity.

The design of a building depends on meeting the minimum requirements for each of these functions. Specifically, regarding structural safety, this involves establishing minimum design loads for various types of loads the structure may encounter. Adhering strictly to loading standards outlined in codes ensures not only the safety of the building but also minimizes the risk of hazards to life and property caused by unsafe structures. Moreover, it helps eliminate unnecessary waste caused by assuming overly heavy loadings, optimizing construction materials and costs.

These loads typically encompass: dead loads, live loads, wind loads and seismic loads. By specifying the requirements for these basic design loads, the standard provides a framework for ensuring that buildings are designed to withstand the various forces and stresses they may encounter during their lifespan. This helps to enhance structural safety, resilience, and performance, ultimately minimizing the risk of damage or failure.

Civil engineers, designers, and architects rely on these provisions to make informed decisions during the planning and design phases, ensuring that buildings meet regulatory requirements, industry standards, and client expectations. Additionally, adherence to these provisions contributes to the overall quality, durability, and sustainability of the built environment.

Part I covers unit weight/mass of material, and parts or components in a building that apply to the determination of dead loads in the design of buildings.

Part II covers imposed loads (live loads) to be assumed in the design of buildings. The imposed loads, specified are minimum loads which should be taken into consideration for the purpose of structural safety of buildings.

Part III specifies wind forces and their effects (static and dynamic) that should be taken into account when designing buildings, structures and components thereof.

Part IV deals with snow loads on roofs of buildings and structures. Roofs should be designed for the actual load due to snow or for the imposed loads specified in Part II.

Part V Special loads and load combinations deals with load and load effects due to temperature changes, soil and hydrostatic pressures, internally generated stresses (due to creep, shrinkage, differential settlement, etc), accidental load etc.

#### *Calculation of Loads as per Indian Standard IS 875*

The dead loads, imposed loads, wind loads, seismic forces, snow loads and other loads, which are specified in **IS 875**, are minimum working loads which should be taken into consideration for purposes of design.

## **II. DEAD LOAD (see 2, 3 and 4)**

The dead load in a building shall comprise the weight of all walls, partitions, floors and roofs, and shall include the weights of all other permanent constructions (including built-in partitions, finishes, cladding and other similarly incorporated architectural and structural items, weight of fixed service equipment) in the building and shall conform to **IS 875 (Part 1)** which specifies unit weight of building materials, unit weight of building parts or components and miscellaneous materials.

## **III. IMPOSED LOAD**

**IS 875 (Part 2)** covers imposed loads to be assumed in the design of buildings. The imposed loads specified herein are minimum loads which should be taken into consideration for the purpose of structural safety of buildings.

The load assumed to be produced by the intended use or occupancy of a building including the weight of movable partitions, distributed and concentrated loads, loads due to impact and vibration, and dust loads but excluding wind, seismic, snow and other loads due to temperature changes, creep, shrinkage, differential settlement, etc.

Some of the categories of building as defined **IS 875 (Part 2)** (see **3.1, 3.1.1** and **4.1.1**) are as given below.

*Assembly Buildings* — These shall include any building or part of a building where



groups of people congregate or gather for amusement, recreation, social, religious, patriotic, civil, travel and similar purposes; for example, theatres, motion picture houses, assembly halls, city halls, marriage halls, town halls, auditoria, exhibition halls, museums, skating rinks, gymnasiums, restaurants (also used as assembly halls), place of worship, dance halls, club rooms, passenger stations and terminals of air, surface and other public transportation services, recreation piers and stadia, etc.

*Business Buildings* — These shall include any building or part of a building, which is used for transaction of business (other than that covered by mercantile buildings); for keeping of accounts and records for similar purposes; offices, banks, professional establishments, court houses, and libraries shall be classified in this group so far as principal function of these is transaction of public business and the keeping of books and records.

*Dwellings* — These shall include any building or part occupied by members of single/multi-family units with independent cooking facilities. These shall also include apartment houses (flats).

*Educational Buildings* — These shall include any building used for school, college or day-care purposes involving assembly for instruction, education or recreation and which is not covered by assembly buildings.

*Industrial Buildings* — These shall include any building or a part of a building or structure, in which products or materials of various kinds and properties are fabricated, assembled, manufactured or processed, for example, assembly plants, industrial laboratories, dry cleaning plants, power plants, generating units, pumping stations, fumigation chambers, laundries, buildings or structures in gas plants, refineries, dairies and saw-mills, etc.

*Institutional Buildings* — These shall include any building or a part thereof, which is used for purposes such as medical or other treatment in case of persons suffering from physical and mental illness, disease or infirmity; care of infants, convalescents or aged persons and for penal or correctional detention in which the liberty of the inmates is restricted. Institutional buildings ordinarily provide sleeping accommodation for the occupants. It includes hospitals, sanatoria, custodial institutions or penal institutions like jails, prisons and reformatories.

*Occupancy or Use Group* — The principal occupancy for which a building or part of a building is used or intended to be used. For the purpose of classification of a building according to occupancy, an occupancy shall be deemed to include subsidiary occupancies which are contingent upon it.

*Office Buildings* — The buildings primarily to be used as an office or for office purposes. Office purposes include the purpose of administration, clerical work, handling money, telephone and telegraph operating, and operating computers, calculating machines, 'clerical work' includes writing, book-keeping, sorting papers, typing, filing, duplicating, drawing of matter for publication and the editorial preparation of matter for publication, etc.

*Mercantile Buildings* — These shall include any building or a part of a building which is used as shops, stores, market for display and sale of merchandize either wholesale or retail. Office, storage and service and facilities incidental to the sale of merchandize and located in the same building shall be included under this group.

*Residential Buildings* — These shall include any building in which sleeping accommodation is provided for normal residential purposes with or without cooking or dining or both facilities (except buildings under institutional buildings). It includes lodging or rooming houses, private dwellings, dormitories, apartment houses (flats) and hotels.

*Storage Buildings* — These shall include any building or part of a building used primarily for the storage or sheltering of goods, wares or merchandize, like warehouses, cold storages, freight depots, transit sheds, store houses, garages, hangers, truck terminals, grain elevators, barns and stables.

### **Imposed Loads on Floors Due to Use and Occupancy** (*see* 3)

The imposed loads to be assumed in the design of buildings shall be the greatest loads that probably will be produced by the intended use or occupancy, but shall not be less than the equivalent minimum loads specified in **IS 875 (Part 2)** subject to any reductions permitted.

Floors shall be investigated for both the uniformly distributed load (UDL) and the corresponding concentrated load specified, and designed for the most adverse effects but they shall not be considered to act simultaneously.

The occupancy classification covers residential buildings (such as dwelling houses, dwelling units planned and executed, hotels, hostels, boarding houses, lodging houses, dormitories and residential clubs, boiler rooms and plant rooms, garages, etc), educational buildings (such as classrooms, dining rooms, etc), institutional buildings (such as bedrooms, kitchens, etc), assembly buildings (such as restaurants, office rooms, lounges, corridors, etc), business and office buildings, (such as banking halls, business computing machine rooms, cafeterias and dining rooms, etc), mercantile building (such as retail shops, wholesale shops, office rooms, industrial buildings, storage building, etc).

The concentrated loads may be assumed to act over an area of 0.3 m × 0.3 m. The uniformly distributed loads shall be applied as static loads over the entire floor area under consideration or a portion of the floor area, whichever arrangement produces critical effects on the structural elements as provided in respective design codes.

In the design of floors, the concentrated loads are considered to be applied in the positions which produce the maximum stresses and where deflection is the main criterion in the positions which produce the maximum deflections. Concentrated load, when used for the calculation of bending and shear, are assumed to act at a point. When used for the calculation of local effects such as crushing or punching, they are assumed to act over an actual area of application of 0.3 m × 0.3 m.

### **Imposed Loads on Roofs** (*see* 4)

**IS 875 (Part 2)** specifies the imposed loads due to use and occupancy of the buildings and the geometry of the types of roofs on flat roofs, sloping roofs and curved roofs.

Concentrated load on roof coverings, loads due to rain, dust loads, loads on members supporting roof coverings have been specified in the standard.

Requirements for imposed horizontal loads on parapets, balustrades and other appurtenances fixed to structure, and on grandstands are covered in detail. Further

standard also covers loading effects due to impact and vibration, rooftop helipad and fire tenders and emergency vehicles.

#### IV. WIND LOAD

Wind forces and their effects (static and dynamic) that should be taken into account when designing buildings, structures and components thereof have been comprehensively enumerated in **IS 875 (Part 3)**.

Wind speeds vary randomly both in time and space and hence assessment of wind loads and response predictions are very important in the design of several buildings and structures.

For normal, short and heavy structures, estimation of loads using static wind analysis has proved to be satisfactory. The details of this method involving important wind characteristics such as the basic wind speeds, terrain categories, modification factors, wind pressure and force coefficients, etc are given in the standard.

Nevertheless, there are various types of structures or their components such as some tall buildings which require investigation of wind induced oscillations. The influence of dynamic velocity fluctuations on the along wind loads (drag loads) for these structures shall be determined using gust factor method, included along with the method for calculation of across wind response of tall buildings.

#### Wind Speed (see 6)

##### Basic Wind Speed

Basic wind speed map of India, as applicable to 10 m height above mean ground level for different zones of the country is referred in the standard. Basic wind speed is based on peak gust velocity averaged over a short time interval of about 3 s and corresponds to mean heights above ground level in an open terrain (Category 2). Basic wind speeds have been worked out for a 50 year return period. Basic wind speed for some important cities/towns is referred in the standard.

##### Design Wind Speed ( $V_z$ ) (see 6.2)

The basic wind speed ( $V_b$ ) for any site shall be obtained from basic wind speed map and shall be modified to include the following effects due to risk level, terrain roughness and height of structure, local topography, and importance factor for the cyclonic region, to get design wind speed,  $V_z$  at any height  $z$ , for the chosen structure. It can be mathematically expressed as follows:

$$V_z = V_b k_1 k_2 k_3 k_4$$

where

$V_z$  = design wind speed at height  $z$ , in m/s;

$V_b$  = basic wind speed, in m/s;

$k_1$  = probability factor (risk coefficient);

$k_2$  = terrain roughness and height factor;

$k_3$  = topography factor; and

$k_4$  = importance factor for the cyclonic region.



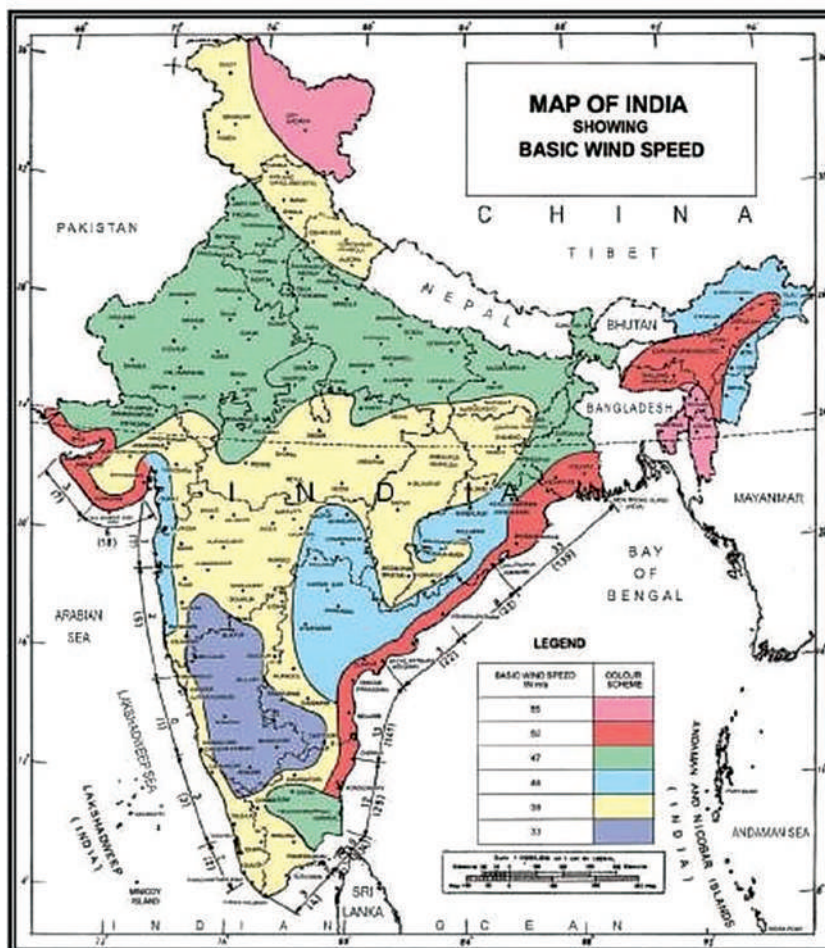

Based upon Survey of India Outline Map printed in 1955. © Government of India Copyright, 2016. The horizontal scale of India extent into the sea is a distance of twelve nautical miles measured from the appropriate base line. The boundary of Bangladesh shown on this map is as delineated from the North Eastern Area (Reorganisation) Act, 1956, but has yet to be verified. Responsibility for correctness of internal details shown on the map rests with the publisher. The state boundaries between Uttaranchal & Uttar Pradesh, Bihar & Jharkhand and Chhattisgarh & Madhya Pradesh have not been verified by Government concerned.

Figure — Basic Wind Speed in m/s (based on 50-years return period)

## Wind Pressures and Forces on Buildings/Structures (see 7)

Standard covers explicit details on calculation on wind load on a building/structure considering the building/structure as a whole; individual structural elements as roofs and walls; and Individual cladding units including glazing and their fixings.

Methods for calculating wind pressure on walls, pitched, hipped and monoslope roofs of clad buildings, canopy roofs, pitched and saw-tooth roofs of multi-span buildings, curved roofs, cylindrical structures, combined roofs, roofs with skylight, grandstands, spheres, etc are covered. Force coefficients for different category of buildings are given in the standard.

The phenomenon of wind interference caused by modification in the wind characteristics produced by the obstruction caused by an object or a building/structure in the path of the wind has been explained and methodology for taking it into account for calculation of wind load and structural design has been explained.

## Dynamic Effects (see 9 and 10)

The standard advises user to investigate to ascertain the importance of wind induced oscillations or excitations in along wind and across wind directions in design of flexible slender structures and structural elements. Tall buildings/structures which are ‘wind

sensitive' shall be designed for dynamic wind loads. Hourly mean wind speed is used as a reference wind speed to be used in dynamic wind analysis. For calculation of along wind loads and response (bending moments, shear forces, or tip deflections) the gust factor (GF) method is used. The across wind design peak base overturning moment and tip deflection shall be calculated as per the standard.

## V. SEISMIC LOADS

Indian Standard **IS 1893** Criteria for Earthquake Resistant Design of Structures, primarily deals with earthquake hazard assessment and earthquake-resistant design of buildings. Large part of land area of India is prone to moderate to severe earthquake shaking, and there are many critical structures built in these areas. Hence, earthquake resistant design is essential. For formulation of this standard, the Earthquake Engineering Sectional Committee, considered an earthquake zoning map based on the maximum intensities at each location as recorded from damage surveys after past earthquakes, taking into account the known magnitudes and the known epicentres, and tectonics of each region.

This standard acknowledges the likelihood of structural damage during strong earthquake ground shaking, despite implementing earthquake-resistant design measures. It focuses on normal structures, excluding those with energy dissipation devices or systems, and provides minimum design force requirements for earthquake resistance. The standard outlines design criteria tailored to the structures, emphasizing the importance of considering unique challenges and local seismic risks.

In essence, adherence to this standard ensures structures are engineered to withstand seismic forces, safeguarding occupants, property, and critical infrastructure during earthquakes. It highlights the necessity of comprehensive planning and engineering expertise to create resilient structures capable of withstanding seismic events effectively. **IS 1893** has been published in following parts:

Part 1 General provisions and buildings

Part 2 Liquid Retaining Tanks

Part 3 Bridges and Retaining Walls

Part 4 Industrial structures and stack-like structures

Part 6 Base isolated buildings

### General Principles and Design Criteria

The characteristics (intensity, duration, frequency content, etc) of seismic ground vibrations expected at any site depend on magnitude of earthquake, its focal depth, epicentral distance, characteristics of the path through which the seismic waves travel, and soil strata on which the structure is founded. The random earthquake ground motions, which cause the structure to oscillate, can be resolved in any three mutually perpendicular directions. The predominant direction of ground vibration is usually horizontal.

Effects of earthquake-induced vertical shaking can be significant for overall stability analysis of structures, especially in structures (a) with large spans, and (b) those in which stability is a criterion for design. Reduction in gravity force due to vertical

ground motions can be detrimental particularly in prestressed horizontal members, cantilevered members and gravity structures. Hence, special attention shall be paid to effects of vertical ground motion on prestressed or cantilevered beams, girders and slabs.

The response of a structure to ground vibrations depends on:

- a) type of foundation;
- b) materials, form, size and mode of construction of structures; and
- c) duration and characteristics of ground motion.

This standard specifies design forces for structures founded on rocks or soils, which do not settle, liquefy or slide due to loss of strength during earthquake ground vibrations.

Actual forces that appear on structures during earthquakes are much higher than the design forces specified in the standard. Ductility arising from inelastic material behaviour with appropriate design and detailing, and overstrength resulting from the additional reserve strength in structures over and above the design strength are relied upon for the deficit in actual and design lateral loads. In other words, earthquake resistant design as per this standard relies on inelastic behaviour of structures. But, the maximum ductility that can be realized in structures is limited. Therefore, structures shall be designed for at least the minimum design lateral force specified in this standard.

Members and their connections of steel structures should be so proportioned that high ductility is obtained in the structure, avoiding premature failure due to elastic or inelastic buckling of any type. Some provisions for appropriate ductile detailing of steel members are given in **IS 800**.

Equipment and other systems, which are supported at various floor levels of a structure, will be subjected to different motions at their support points. In such cases, it may be necessary to obtain floor response spectra for design of equipment and its supports. For details, reference may be made to **IS 1893 (Part 4)**.

### **Assumptions**

The following assumptions shall be made in the earthquake-resistant design of structures:

- a) Earthquake ground motions are complex and irregular, consisting of several frequencies and of varying amplitudes each lasting for a small duration. Therefore, usually, resonance of the type as visualized under steady-state sinusoidal excitations will not occur, as it would need time to build up such amplitudes. But, there are exceptions where resonance-like conditions have been seen to occur between long distance waves and tall structures founded on deep soft soils.
- b) Earthquake is not likely to occur simultaneously with high wind, maximum flood or maximum sea waves.
- c) The values of elastic modulus of materials, wherever required, will be taken as for static analysis, unless more definite values are available for use in dynamic conditions.

The standard specifies load combinations and increase in permissible stresses. Design for horizontal earthquake load, vertical earthquake effect and for three directional earthquake ground shaking has been covered.

For the purpose of determining design seismic force, the country is classified into four seismic zones, namely Zone II, Zone III, Zone IV and Zone V. Method for calculation of design seismic force has been covered.

Specific design requirements for building with regular and irregular configurations has been covered in detail.

The **IS 1893 (Part 6)** provides guidelines for estimation of design lateral force and displacement to be considered in the design of buildings with base isolation system, method of structural analysis to be adopted in the analysis of such buildings, and guidelines for testing of the seismic isolation devices that are used in such buildings. The underlying philosophy of this standard is that a base isolated building will perform better than a conventional building (with fixed base), when subjected to moderate to severe earthquake shaking. The objective of the standard is to minimize damage to base isolated buildings and their contents and enhance the likelihood of continued functionality of the building.

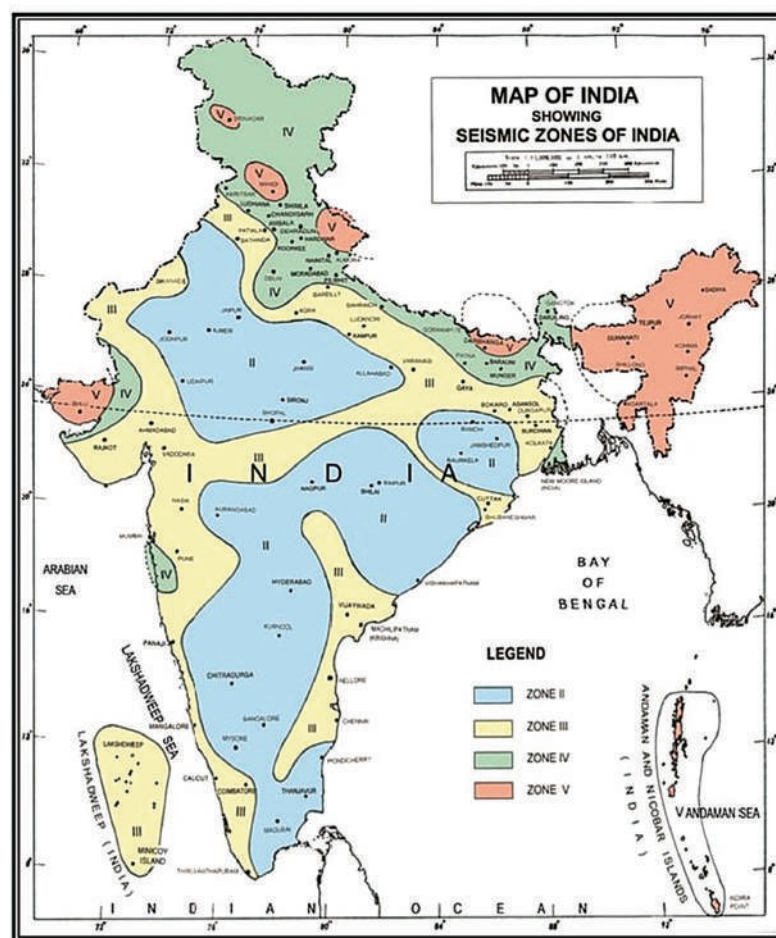

Based upon Survey of India Outline Map printed in 1993. © Government of India Copyright, 2005.  
 The territorial waters of India extend into the sea to a distance of twelve nautical miles measured from the appropriate base line.  
 The boundary of Meghalaya shown on this map is as interpreted from the North-Eastern Areas (Reorganisation) Act, 1951, but has yet to be verified.  
 Responsibility for correctness of internal details shown on the map rests with the publisher.  
 The state boundaries between Uttaranchal & Uttar Pradesh, Bihar & Jharkhand and Chhattisgarh & Madhya Pradesh have not been verified by Governments concerned.  
 NOTE — Towns falling at the boundary of zones demarcation line between two zones shall be considered in higher zone.

**Figure — Seismic Zones of India**

## VI. SNOW LOAD ON ROOF(S)

**IS 875 (Part 4)** deals with snow loads on roofs of buildings and structures. Roofs should be designed for the actual load due to snow or for the imposed loads specified in **IS 875 (Part 2)**, whichever is more severe.

The minimum design snow load on a roof area or any other area above ground which is subjected to snow accumulation is obtained by multiplying the characteristic value of snow load on the ground,  $S_0$  by the shape coefficient,  $\mu$  as applicable to the particular roof area considered and it is expressed as:

$$S = \mu S_0$$

where

$S$  = design snow load on plan area of roof, in kPa (1 kPa =  $10^3$  N/m<sup>2</sup>);

$\mu$  = shape coefficient; and

$S_0$  = characteristic ground snow load, in kPa.

### Characteristic Ground Snow Load (**S<sub>0</sub>**)

The characteristic ground snow load ( $S_0$ ) at any site is defined based on an annual probability of exceedance of 0.034 and corresponds to a mean return period of 30 years. The value of  $S_0$  (kPa) for any site in snow-bound regions of Indian Himalayas should be obtained using the procedure described in the standard.

Standard gives the characteristic ground snow load map for union territory of Jammu and Kashmir, union territory of Ladakh, Himachal Pradesh, Uttarakhand and Sikkim resulting from studies conducted by snow and Avalanche Study Establishment (DRDO) Chandigarh.

A loading corresponding to severe imbalances resulting from snow removal, redistribution, sliding, melting, etc (for example, zero snow load on specific parts of the roof) should always be considered.

Roofs shall be designed to preclude ponding instability. For flat roofs (or with a small slope), roof deflections caused by snow loads shall be investigated when determining the likelihood of ponding instability from rain-on-snow or from snow meltwater.

Shape coefficients for selected types of roofs such as mono pitched and simple pitched roofs, multiple pitched roofs, simple curved roofs, multilevel roofs, complex multilevel roofs, roofs with local projections and obstructions have been given in the standard. Further for areas which are exposed to wind in addition to snow load, shape coefficients have been given.

Standard specifies that ice loads are required to be taken into account in the design of overhead electrical transmission and communication lines, over-head contact lines for electric traction, aerial masts and similar structures in zones subjected to ice formation.

## VII. SPECIAL LOADS

**IS 875 (Part 5)** covers the loads and load effects due to temperature changes, soil and hydrostatic pressures, internally generating stresses (due to creep, shrinkage,

differential settlement, etc), accidental loads, etc, which need to be considered in the design of buildings as appropriate. **IS 875 (Part 5)** includes guidance on load combinations.

### **VIII. LOAD COMBINATIONS**

A judicious combination of the loads keeping in view the probability of their acting together, and their disposition in relation to other loads and severity of stresses or deformations caused by the combinations of the various loads is necessary to ensure the required safety and economy in the design of a structure.

Keeping the aspect specified above, the various loads should, therefore, be combined in accordance with the stipulation in the relevant design codes. In the absence of such recommendations, the following loading combinations, whichever combination produces the most unfavourable effect in the building, foundation or structural member concerned may be adopted (as a general guidance). It should also be recognized in load combinations that the simultaneous occurrence of maximum values of wind, earthquake, imposed and snow loads is not likely.

- a) DL
- b) DL and IL
- c) DL and WL
- d) DL and EL
- e) DL and TL
- f) DL, IL and WL
- g) DL, IL and EL
- h) DL, IL and TL
- i) DL, WL and TL
- j) DL, EL and TL
- k) DL, IL, WL and TL
- l) DL, IL, EL and TL

(DL = dead load, IL = imposed load, WL = wind load, EL = earthquake load and TL = temperature load) Detailed guidance is available in the standard.

### **IX. MULTI-HAZARD RISK IN VARIOUS DISTRICTS OF INDIA**

**IS 875 (Part 5)** recognizes multi-hazard risk concept the commonly encountered hazards are: a) Earthquake,

- b) Cyclone,
- c) Wind storm,
- d) Floods,
- e) Landslides,
- f) Liquefaction of soils,
- g) Extreme winds,
- h) Cloud bursts, and
- j) Failure of slopes.

A study of the earthquake, wind/cyclone, and flood hazard maps of India indicate that there are several areas in the country which run the risk of being affected by more than one of these hazards. Further, there may be instances where one hazard may cause occurrence or accentuation of another hazard such as landslides may be triggered/accelerated by earthquakes and wind storms and floods by the cyclones. It is important to study and examine the possibility of occurrence of multiple hazards, as applicable to an area. However, it is not economically viable to design all the structures for multiple hazards. The special structures such as nuclear power plants, and life line structures such as hospitals and emergency rescue shelters may be designed for multiple hazards. For such special structures, site specific data have to be collected and the design be carried out based on the accepted levels of risk. The factors that have to be considered in determining this risk are:

- a) The severity of the hazard characterized by M.M. (or M.S.K.) intensity in the case of earthquake; the duration and velocity of wind in the storms; and unprotected or protected situation of flood prone areas; and
- b) The frequency of occurrence of the severe hazards.

### **Multi-Hazard Prone Areas**

The criteria adopted for identifying multi-hazard prone areas may be as follows:

- a) *Earthquake and Flood Risk Prone* — Districts which have seismic zone of intensity 7 or more and also flood prone unprotected or protected area. Earthquake and flood can occur separately or simultaneously.
- b) *Cyclone and Flood Risk Prone* — Districts which have cyclone and flood prone areas. Here floods can occur separately from cyclones, but simultaneous also along with possibility of storm surge too.
- c) *Earthquake, Cyclone and Flood Risk Prone* — Districts which have earthquake zone of intensity 7 or more, cyclone prone as well as flood prone (protected or unprotected) areas. Here the three hazards can occur separately and also simultaneously as in (a) and (b) above but earthquake and cyclone will be assumed to occur separately only.
- d) *Earthquake and Cyclone Risk Prone* — Districts which have earthquake zone of intensity 7 or more and prone to cyclone hazard too. The two will be assumed to occur separately.

Based on the approach given above, the districts with multi-hazard risk are given in this standard.



**CHAPTER VI**  
**DESIGN OF STEEL STRUCTURES**



# CHAPTER VI

## DESIGN OF STEEL STRUCTURES

### INTRODUCTION

This section covers criteria and method for design for steel structures as per National Building Code of India (Part 6/Section 6 Structural Design — Steel) and IS 800 General construction in Steel — Code of practice.

Indian Standard IS 800 and Special Publication 7 'National Building Code' (Part 6/Section 6) covers the structural design aspects of steel structures in building. IS 800 is the basic code for general construction in steel structures and is the prime document for any structural design and has influence on many other codes governing the design of other special steel structures, such as towers, bridges, silos, chimneys, etc. Section 6/Part 6 Structural Design of the National Building Code (NBC) of India 2016, provides for structural adequacy of buildings and usage of materials and technology for building design.

In steel construction, these standards have a particularly crucial role due to steel's integral role in infrastructure and engineering applications. Design as per these standards helps to ensure a safe, efficient, and environmentally sustainable steel construction. They represent a significant step forward in aligning industry practices with the latest advancements and standards, paving the way for a new era of innovation and excellence in steel construction. Leveraging the knowledge and contributions from various academic, research, design, and contracting organizations, taking benefit from diverse perspectives and extensive industry insights. Overall, the collaborative efforts of these institutions and organizations reflect a concerted commitment to advancing the state of the art in steel construction and promoting industry growth, safety, and sustainability.

Reference to all the clauses in this chapter is drawn with respect to **SP 7 : 2016, Part 6 Section 6**

### I. MATERIALS

#### Structural Steel

All the structural steel used in general construction, coming under the purview of **IS 800/NBC Part 6 Section 6** shall before fabrication conform to **IS 2062**.

Physical properties of structural steel irrespective of its grade may be taken as (see **8.2.4.1**):

- Unit mass of steel,  $\rho = 7850 \text{ kg/m}^3$ ;
- Modulus of elasticity,  $E = 2.0 \times 10^5 \text{ N/mm}^2(\text{MPa})$ ;
- Poisson ratio,  $\nu = 0.3$ ;
- Modulus of rigidity,  $G = 0.769 \times 10^5 \text{ N/mm}^2(\text{MPa})$ ; and
- Coefficient of thermal expansion  $\alpha_t = 12 \times 10^{-6}/^\circ\text{C}$ .

### **Mechanical Properties of Structural Steel (see 8.2.4.2)**

The principal mechanical properties of the structural steel to be considered in design of structures are the following:

- a) yield stress,  $f_y$ ;
- b) tensile or ultimate stress,  $f_u$ ;
- c) maximum percent elongation on a standard gauge length; and
- d) notch toughness.

### **Steel Tubes/Rivets/Bolts, Nuts and Washers (see 8.2.4.2.1, 8.3, 8.4)**

Standards as listed below shall be used for the manufacture of the following:

Steel tubes as per IS 1161; Rivets as per IS 7557, IS 2062 or IS 1148; and bolts, nuts and washers as per IS 1363, IS 1367, IS 3640, IS 3757, IS 5369, IS 5370, IS 5372, IS 5374, IS 5624, IS 6610, IS 6623, IS 6639, IS 649.

## **II. GENERAL DESIGN REQUIREMENTS (see 9)**

The objective of design is the achievement of an acceptable probability that structures will perform satisfactorily for the intended purpose during the design life. With an appropriate degree of safety, they should sustain all the loads and deformations, during construction and use and have adequate resistance to certain expected accidental loads and fire. Structure should be stable and have alternate load paths to prevent disproportionate overall collapse under accidental loading.

Structure and its elements shall normally, be designed by the limit state method.

### **Loads and Forces (see 9.2)**

For the purpose of designing any element, member or a structure, the following loads (actions) and their effects shall be taken into account, where applicable, with partial safety factors and combinations:

- a) Dead loads;
- b) Imposed loads (live load, crane load, snow load, dust load, wave load, earth pressures, etc); c) Wind loads;
- d) Earthquake loads;
- e) Erection loads;
- f) Accidental loads such as those due to blast, impact of vehicles, etc; and
- g) Secondary effects due to contraction or expansion resulting from temperature changes, differential settlements of the structure as a whole or of its components, eccentric connections, rigidity of joints differing from design assumptions.

For various loads, see **IS 875 (Part 1 to Part 5)**. Salient considerations pertaining to loads are covered in Chapter 5 Earthquake loads shall be assumed as per the recommendations of **IS 1893 (Part 1)**.

### **Load Combinations (see 9.5)**

Load combinations for design purposes shall be those that produce maximum forces and effects and consequently maximum stresses and deformations. The following

combination of loads with appropriate partial safety factors may be considered:

- a) Dead load + imposed load,
- b) Dead load + imposed load + wind or earthquake load,
- c) Dead load + wind or earthquake load.

Wind load and earthquake loads shall not be assumed to act simultaneously. The effect of each shall be considered separately.

### **Geometrical Properties** (see 9.6)

The geometrical properties of the gross and the effective cross sections of a member or part thereof, are covered in IS 800. Plate elements of a cross section may buckle locally due to compressive stresses. The local buckling can be avoided before the limit state is achieved by limiting the width to thickness ratio of each element of a cross section subjected to compression due to axial force, moment or shear.

When plastic analysis is used, the members shall be capable of forming plastic hinges with sufficient rotation capacity (ductility) without local buckling, to enable the redistribution of bending moment required before formation of the failure mechanism. When elastic analysis is used, the member shall be capable of developing the yield stress under compression without local buckling. On the basis of these, four classes of sections are defined in IS 800.

four classes of sections are defined as follows:

- a) Class 1 (Plastic) “ Cross sections, which can develop plastic hinges and have the rotation capacity required for failure of the structure by formation of plastic mechanism. The width to thickness ratio of plate elements shall be less than that specified under Class 1 (Plastic), in Table 2.
- b) Class 2 (Compact) “ Cross sections, which can develop plastic moment of resistance, but have inadequate plastic hinge rotation capacity for formation of plastic mechanism, due to local buckling. The width to thickness ratio of plate elements shall be less than that specified under Class 2 (Compact), but greater than that specified under Class 1 (Plastic), in Table 2.
- c) Class 3 (Semi-compact) “ Cross sections, in which the extreme fiber in compression can reach yield stress, but cannot develop the plastic moment of resistance, due to local buckling. The width to thickness ratio of plate elements shall be less than that specified under Class 3 (Semi-compact), but greater than that specified under Class 2 (Compact), in Table 2.
- d) Class 4 (Slender) “ Cross sections in which the elements buckle locally even before reaching yield stress. The width to thickness ratio of plate elements shall be greater than that specified under Class 3 (Semicompact), in Table 2. In such cases, the effective sections for design shall be calculated either by following the provisions of good practice to account for the post-local-buckling strength or by conservatively deducting width of the compression plate element in excess of the semi-compact section limit (see Fig. 2b and Fig. 2c).

The width to thickness ratio of elements shall be greater than that specified under respective class, in IS 800. When different elements of a cross section fall under

different classes, the section shall be classified as governed by the most critical element. The maximum value of limiting width to thickness ratios of elements for different classifications of sections are given in Fig. below. The effective section in case of Class 4 (slender elements) may be conservatively taken as shown in Fig. 2B and Fig. 2C of **SP 7** reproduced below. The maximum effective slenderness ratio shall not exceed those given in Table 2 of **SP 7**.

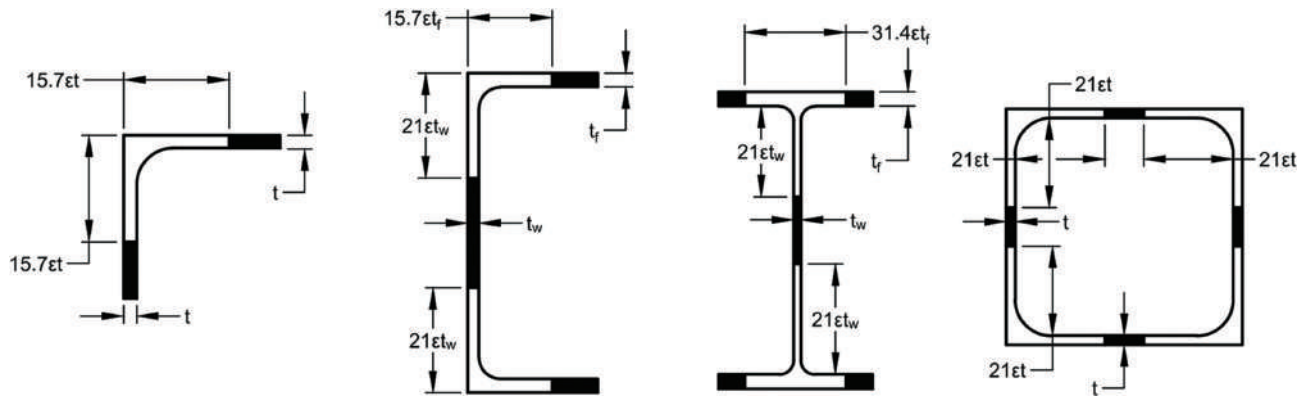

*Effective Section of Slender Members Under Compression, Pure*

### Connecting Codes to Classrooms: A Guide to Steel Structures Design

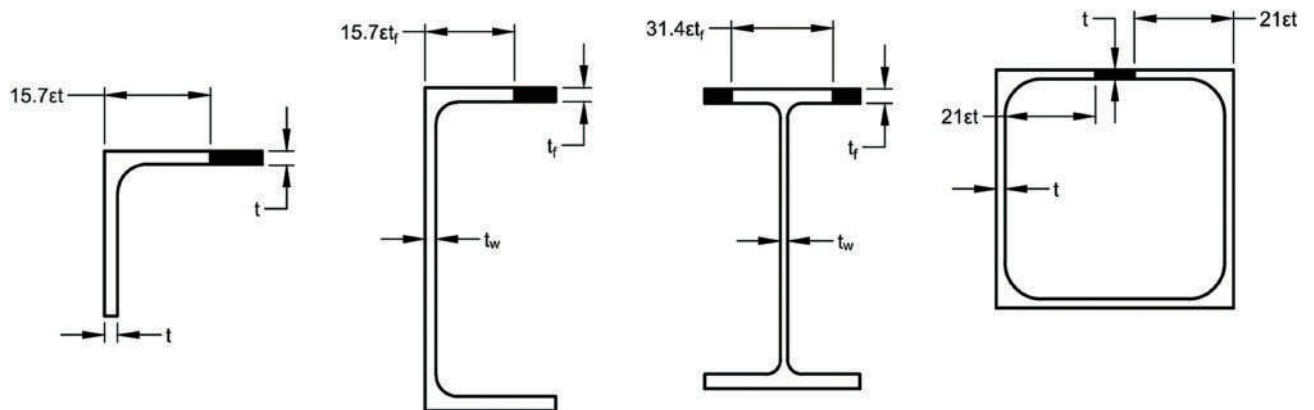

*Effective Section of Slender Members Under Compression, Flexural Classification of Sections*

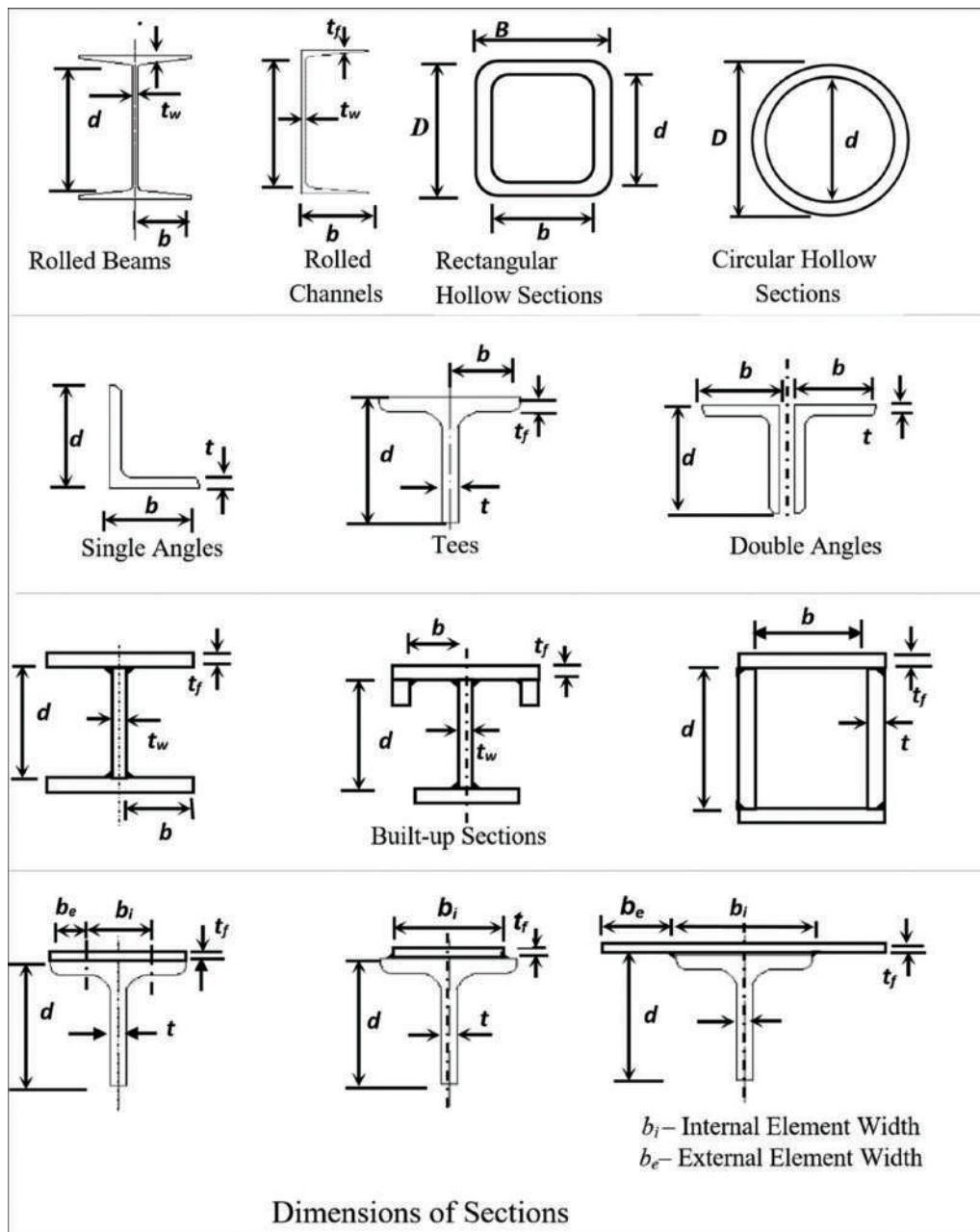

Figure — Classification of Sections

### Resistance to Horizontal Forces (see 9.9)

In designing the steel frame work of a building, provision shall be made (by adequate moment connections or by a system of bracing) to effectively transmit to the foundations all the horizontal forces, giving due allowance for the stiffening effect of the walls and floors, where applicable. When the walls, or walls and floors and/or roofs are capable of effectively transmitting all the horizontal forces directly to the foundations, the structural steel framework may be designed without considering the effect of wind or earthquake.

Wind and earthquake forces are reversible and therefore call for rigidity and strength under force reversal in both longitudinal and transverse directions. To resist torsional effects of wind and earthquake forces, bracings in plan should be provided and integrally connected with the longitudinal and transverse bracings, to impart adequate torsional resistance to the structure.

The foundations of a building or other structures shall be designed to provide the rigidity and strength that has been assumed in the analysis and design of the superstructure. For eccentrically placed loads, beams/it's connections shall be designed for torsion.

### Expansion Joints ( see 9.10)

Structures in which marked changes in plan dimensions take place abruptly, shall be provided with expansion joints at the section where such changes occur. Expansion joints shall be so provided that the necessary movement occurs with minimum resistance at the joint. The gap at the expansion joint should be such that it accommodates the expected expansion/contraction due to seasonal and diurnal variation of temperature; and it avoids pounding

of adjacent units under earthquake. The structure adjacent to the joint should preferably be supported on separate columns but not necessarily on separate foundations.

If one bay of longitudinal bracing is provided at the centre of the building or building section, the length of the building section may be restricted to 180 m in case of covered buildings and 120 m in case of open gantries.

If more than one bay of longitudinal bracing is provided near the centre of the building/ section, the maximum centre line distance between the two lines of bracing may be restricted to 50 m for covered buildings (and 30 m for open gantries) and the maximum distance between the centre of the bracing to the nearest expansion joint/end of building or section may be restricted to 90 m (60 m in case of open gantries). The maximum length of the building section thus may be restricted to 230 m for covered buildings (150 m for open gantries). Beyond this, suitable expansion joints shall be provided.

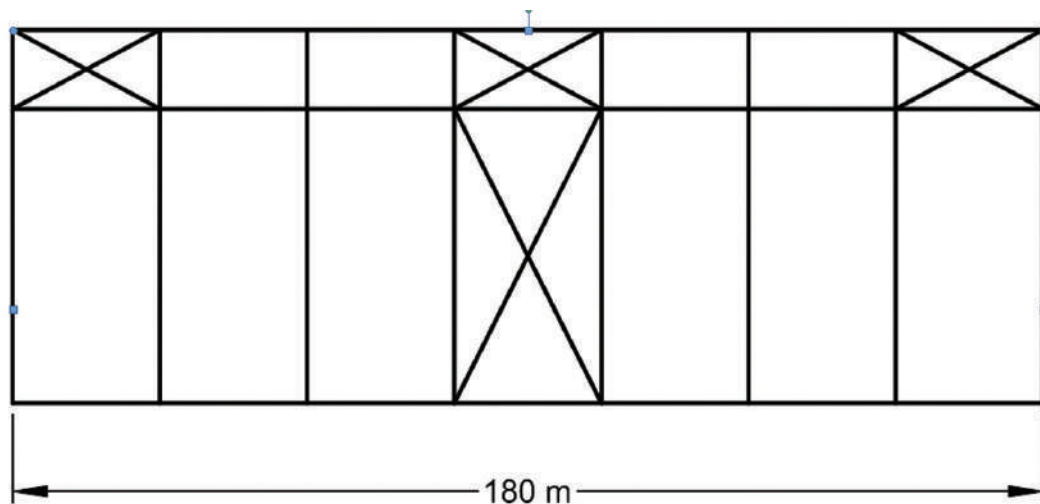

End of Building/Section

*Figure — Maximum Length of Building with One Bay of Bracing*

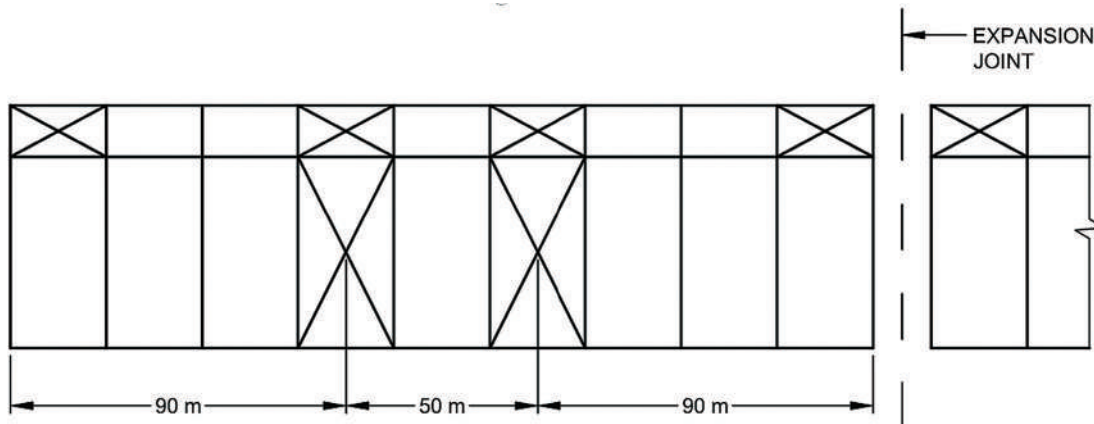

Figure — Maximum Length of Covered Building/Section with Two Bays of Bracings

### III. METHODS OF STRUCTURAL ANALYSIS (see 10)

Elastic analysis, plastic analysis, advanced analysis or dynamic analysis may be used in accordance with IS 800.

For the purpose of analysis and design, the structural frames are classified as non-sway and sway frames.

For the purpose of analysis and design, the structural frames are classified as non-sway and sway frames as given below:

- a) Non-sway frame — One in which the transverse displacement of one end of the member relative to the other end is effectively prevented. This applies to triangulated frames and trusses or to frames where in-plane stiffness is provided by bracings, or by shear walls, or by floor slabs and roof decks secured horizontally to walls or to bracing systems parallel to the plane of loading and bending of the frame.
- b) Sway frame — One in which the transverse displacement of one end of the member relative to the other end is not effectively prevented. Such members and frames occur in structures which depend on flexural action of members to resist lateral loads and sway, as in moment resisting frames.
- c) A rigid jointed multi-storey frame may be considered as a non-sway frame if in every individual storey, the deflection  $\delta$ , over a storey height  $h_s$ , due to the notional horizontal loading given in 10.3.6 satisfies the following criteria:

- 1) For clad frames, when the stiffening effect of the cladding is not taken into account in the deflection calculations:

$$\delta \leq \frac{h_s}{2000}$$

- 2) For unclad frame or clad frames, when the stiffening effect of the cladding is taken into account in the deflection calculations:

$$\delta \leq \frac{h_s}{4000}$$

- 3) A frame, which when analyzed considering all the lateral supporting system does not comply with the above criteria, should be classified as a sway frame, even if it is braced or otherwise laterally stiffened.

The effects of design action in the members and connections of a structure shall be determined by assuming singly or in combination of rigid construction/semi-rigid construction/simple construction.

Special attention should be given to the design of all connections which shall be consistent with the form of construction, and the behaviour of the connections shall not adversely affect any other part of the structure beyond what is allowed for in design.

### **Assumptions in Analysis (see 10.3)**

The structure shall be analyzed in its entirety except for certain conditions as detailed in the standard. The span length of a flexural member in a continuous frame system shall be taken as the centre-to-centre distance between the supports. For building structures, the various arrangements of imposed loads considered for the analysis, shall include at least the following:

- a) Where the loading pattern is fixed, the arrangement concerned.
- b) Where the imposed load is variable and not greater than three-quarters of the dead load, the imposed load may be taken to be acting on all spans.
- c) Where the imposed load is variable and exceeds three-quarters of the dead load, arrangements of imposed load acting on the floor under consideration shall include the following cases:
  - 1) Imposed load on alternate spans,
  - 2) Imposed load on two adjacent spans, and
  - 3) Imposed load on all the spans.

In the analysis of all structures the appropriate base stiffness about the axis under consideration shall be used. In the absence of the knowledge of the pedestal and foundation stiffness, specific guidance as given in the standard shall be followed. In simple construction, bending members may be assumed to have their ends connected for shear only and to be free to rotate. In triangulated structures, axial forces may be determined by assuming that all members are pin connected. To analyze a frame subjected to gravity loads, considering the sway stability of the frame, notional horizontal forces should be applied.

### **Elastic Analysis (see 10.4)**

Individual members shall be assumed to remain elastic under the action of the factored design loads for all limit states. The effect of haunching or any variation of the cross section along the axis of a member shall be considered, and where significant, shall be taken into account in the determination of the member stiffness.

### **Plastic Analysis (see 10.5)**

The effects of design action throughout or on part of a structure may be determined by a plastic analysis. The distribution of design action effects shall satisfy equilibrium



and the boundary conditions. The design action effects shall be determined using a rigid-plastic analysis.

#### **IV. LIMIT STATE DESIGN (see 11)**

In the limit state design method, the structure shall be designed to withstand safely all loads likely to act on it throughout its life. It shall not suffer total collapse under accidental loads such as from explosions or impact or due to consequences of human error to an extent beyond the local damages. The acceptable limit for the safety and serviceability requirements before failure occurs is called a limit state. In general, the structure shall be designed on the basis of the most critical limit state and shall be checked for other limit states.

Steel structures are to be designed and constructed to satisfy the design requirements with regard to stability, strength, serviceability, brittle fracture, fatigue, fire, and durability such that they meet the following:

- a) Remain fit with adequate reliability and be able to sustain all actions (loads) and other influences experienced during construction and use;
- b) Have adequate durability under normal maintenance;
- c) Do not suffer overall damage or collapse disproportionately under accidental events like explosions, vehicle impact or due to consequences of human error to an extent beyond local damage. The potential for catastrophic damage shall be limited or avoided by appropriate choice of one or more of the following:
  - 1) Avoiding, eliminating or reducing exposure to hazards, which the structure is likely to sustain.
  - 2) Choosing structural forms, layouts and details, and designing such that:
    - i) the structure has low sensitivity to hazardous conditions; and ii) the structure survives with only local damage even after serious damage to any one individual element by the hazard;
  - 3) Choosing suitable material, design and detailing procedure, construction specifications, and control procedures for shop fabrication and field construction as relevant to the particular structure.

Structures designed for unusual or special functions shall comply with any other relevant additional limit state considered appropriate to that structure.

Generally, structures and elements shall be designed by limit state method. Where limit state method cannot be conveniently adopted, working stress design may be used.

#### **Design action < Design strength**

Limit states are the states beyond which the structure no longer satisfies the performance requirements specified. The limit states are classified as:

- a) Limit state of strength; and
- b) Limit state of serviceability.

The limit states of strength are those associated with failures (or imminent failure), under the action of probable and most unfavourable combination of loads on the structure using the appropriate partial safety factors, which may endanger the safety of life and property. The limit state of strength includes:

- a) loss of equilibrium of the structure as a whole or any of its parts or components;
- b) loss of stability of the structure (including the effect of sway where appropriate and overturning) or any of its parts including supports and foundations;
- c) failure by excessive deformation, rupture of the structure or any of its parts or components;
- d) fracture due to fatigue; and
- e) brittle fracture.

The limit state of serviceability include:

- a) deformation and deflections, which may adversely affect the appearance or effective use of the structure or may cause improper functioning of equipment or services or may cause damages to finishes and nonstructural members;
- b) vibrations in the structure or any of its components causing discomfort to people, damages to the structure, its contents or which may limit its functional effectiveness. Special consideration shall be given to systems susceptible to vibration, such as large open floor areas free of partitions to ensure that such vibrations are acceptable for the intended use and occupancy;
- c) repairable damage or crack due to fatigue;
- d) corrosion, durability; and
- e) fire.

### **Actions (see 11.3)**

The actions (loads) to be considered in design include direct actions (loads) experienced by the structure due to self-weight, external actions, etc, and imposed deformations such as that due to temperature and settlements.

Actions are classified by their variation with time as permanent actions ( $Q_p$ ), variable actions ( $Q_v$ ), accidental actions ( $Q_a$ ).

The characteristic actions,  $Q_c$ , are the values of the different actions that are not expected to be exceeded with more than 5 percent probability, during the life of the structure and they are taken as, the self-weight, the variable loads, the upper limit with a specified probability (usually 5 percent) not exceeding during some reference period (design life) and actions specified by client, or designer.

### **Characteristic Actions (Loads) (see 11.3.2)**

The characteristic actions,  $Q_c$ , are the values of the different actions that are not expected to be exceeded with more than 5 percent probability, during the life of the structure and they are taken as,

- a) the self-weight, in most cases calculated on the basis of nominal dimensions and unit weights.
- b) the variable loads, values of which are specified in relevant standard.
- c) the upper limit with a specified probability (usually 5 percent) not exceeding during some reference period (design life).
- d) specified by client, or by designer in consultation with client, provided they satisfy the minimum provisions of the relevant loading standard.

**Design Actions** (see 11.3.3)

The design action,  $Q_d$ , is expressed as  $Q_d = \sum_k \gamma_{fk} Q_{ck}$

where

$\gamma_{fk}$  = partial safety factor for different loads  $k$  to account for:

- a) possibility of unfavourable deviation of the load from the characteristic value;
- b) possibility of inaccurate assessment of the load;
- c) uncertainty in the assessment of effects of the load; and
- d) uncertainty in the assessment of the limit states being considered.

The loads or load effects shall be multiplied by the relevant  $\gamma_f$  factors, given in IS 800, to get the design loads or design load effects.

**Strength (see 11.4)**

The ultimate strength calculation may require consideration of the following:

- a) Loss of equilibrium of the structure or any part of it, considered as a rigid body, and
- b) Failure by excessive deformation, rupture or loss of stability of the structure or any part of it including support and foundation.

**Design Strength (see 11.4.1)**

The design strength,  $S_d$ , is obtained as given below from ultimate strength,  $S_u$  and partial safety factors for materials,  $\gamma_m$  given in IS 800.

$$S_d = S_u / \gamma_m$$

where partial safety factor for materials,  $\gamma_m$  account for:

- a) possibility of unfavourable deviation of material strength from the characteristic value;
- b) possibility of unfavourable variation of member sizes;
- c) possibility of unfavourable reduction in member strength due to fabrication and tolerances; and

- d) uncertainty in the calculation of strength of the members.

### **Stability (see 11.5.1)**

Stability shall be ensured for the structure as a whole and for each of its elements. This should include, overall frame stability against overturning and sway.

### **Fatigue (see 11.5.2)**

Generally fatigue need not be considered unless a structure or element is subjected to numerous significant fluctuations of stress. Stress changes due to fluctuations in wind loading normally need not be considered. When designing for fatigue, the partial safety factor for load,  $\gamma_p$ , equal to unity shall be used for the load causing stress fluctuation and stress range.

### **Plastic Collapse (see 11.5.3)**

Plastic analysis and design may be used, if the requirement specified under the plastic method of analysis are satisfied.

### **Limit State of Serviceability (see 11.6)**

Serviceability limit state is related to the criteria governing normal use. Serviceability limit state is limit state beyond which the service criteria specified below, are no longer met:

- a) Deflection limit;
- b) Vibration limit;
- c) Durability consideration; and
- d) Fire resistance.

Unless specified otherwise, partial safety factor for loads,  $\gamma_p$ , of value equal to unity shall be used for all loads leading to serviceability limit states to check the adequacy of the structure under serviceability limit states.

## **V. DESIGN OF TENSION MEMBERS (see 12)**

### **Tension Members (see 12.1)**

Tension members are linear members in which axial forces act to cause elongation (stretch). Such members can sustain loads up to the ultimate load, at which stage they may fail by rupture at a critical section. However, if the gross area of the member yields over a major portion of its length before the rupture load is reached, the member may become non-functional due to excessive elongation. Plates and other rolled sections in tension may also fail by block shear of end bolted regions.

The factored design tension  $T$ , in the members shall satisfy the following requirement:

$$T < T_d$$

where

$T_d$  = Design strength of the member.

The design strength of a member under axial tension,  $T_d$ , is the lowest of the design strength due to yielding of gross section,  $T_{dg}$ ; rupture strength of critical section,  $T_{dn}$ ; and block shear  $T_{db}$ , given in the standard, respectively. The design strength due to yielding, rupture of critical sections like plates, threaded rods, single angles and other sections are also covered in **SP 7**.

## VI. DESIGN OF COMPRESSION MEMBERS (*see* 13)

### Design Strength (*see* 13.1)

Common hot rolled and built-up steel members used for carrying axial compression, usually fail by flexural buckling. The buckling strength of these members is affected by residual stresses, initial bow and accidental eccentricities of load.

The factored design compression,  $P$  in members shall satisfy the following requirement:

$$P < P_d \text{ (where } P_d = A_e f_{cd} \text{)}$$

where

$A_e$  = effective sectional area; and

$f_{cd}$  = design compressive stress.

The standard specifies requirements for calculation of effective length of compression members (*see* 13.2), design details (*see* 13.3), column bases (*see* 13.4), angle struts (*see* 13.5), design of laced columns (*see* 13.6) and battened columns (*see* 13.7).

## VII. DESIGN OF MEMBERS SUBJECTED TO BENDING (*see* 14)

### General

Members subjected to predominant bending shall have adequate design strength to resist bending moment, shear force, and concentrated forces imposed upon and their combinations. Further, the members shall satisfy the deflection limitation, as serviceability criteria.

Design strength in bending (flexure), effective length for lateral torsional buckling, shear, stiffened web panel, stiffener design, box girders, purlins and sheeting rails (girts) and bending in a non-principal plane has been covered in the standard (*see* 14.2 to 14.10).

## VIII. DESIGN OF MEMBERS SUBJECTED TO COMBINED FORCES (*see* 15)

The design of members subjected to combined forces, such as shear force and bending, axial force and bending, or shear force, axial force and bending has been covered in detail in IS 800.

## IX. CONNECTIONS (*see* 16)

Connection elements consist of components such as cleats, gusset plates, brackets, connecting plates and connectors such as rivets, bolts, pins, and welds. The connections in a structure shall be designed so as to be consistent with the assumptions made in the analysis of the structure and comply with the requirements specified in this section. Connections shall be capable of transmitting the calculated design actions.

The standard explains in detail the requirements for location of fasteners, bearing type bolts, friction grip type bolting, welds and welding, design of connections, minimum design action on connection, intersections, choice of fasteners, connection components and lug angles.

## **X. WORKING STRESS DESIGN (see 17)**

General design requirements as stated above shall apply and methods of structural analysis shall also apply in working stress design. The elastic analysis method shall be used in the working stress design requirements for tension members, compression members, members subjected to bending, combined stress and connections.

## **XI. FATIGUE (see 19)**

Structure and structural elements subject to loading that could lead to fatigue failure shall be designed against fatigue as given in the standard. For the purpose of design against fatigue, different details (of members and connections) are classified under different fatigue class. The design stress range corresponding to various number of cycles, are given for each fatigue class. The requirements shall be satisfied with, at each critical location of the structure subjected to cyclic loading, considering relevant number of cycles and magnitudes of stress range expected to be experienced during the life of the structure.

## **XII. DESIGN ASSISTED BY TESTING (see 20)**

Testing of structures, members or components of structures is not required when designed in accordance with Indian Standards. However, the standard allows design assisted by testing as an alternative to calculations or may become necessary in special circumstances. Criteria for acceptance for strength and serviceability have been specified.

## **XIII. DURABILITY (see 21)**

A durable steel structure is one that performs satisfactorily the desired function in the working environment under the anticipated exposure condition during its service life, without deterioration of the cross sectional area and loss of strength due to corrosion. The material used, the detailing, fabrication, erection and surface protection measures should all address the corrosion protection and durability requirements.

### **Requirements for Durability**

The design, fabrication and erection details of exposed structures should be such that good drainage of water is ensured. The details of connections should ensure that, all exposed surfaces are easily accessible for inspection and maintenance; and all surfaces, not so easily accessible are completely sealed against ingress of moisture.

The general environment, to which a steel structure is exposed during its working life is classified into five levels of severity (mild, moderate, severe, very severe and extreme) in the standard.

Appropriate coatings may be used when surfaces of structural steel are exposed to concentration of sulphates (SO<sub>3</sub>) in soil, ground water, etc.

When exposed to very high sulphate concentrations of more than 2 percent in soil and 5 percent in water, some form of lining such as polyethylene, polychloroprene sheet or

surface coating based on asphalt, chlorinated rubber, epoxy or polymethane material should be used to completely avoid access of the solution to the steel surface.

#### **XIV. FIRE RESISTANCE ( see 22)**

Requirements for fire resistant building elements are covered.

#### **XV. FABRICATION AND ERECTION ( see 23)**

Standard specifies the tolerances for fabrication and erection of steel structures. Fabrication procedures such as cutting, shearing, thermal cutting, holing, punching have been described. All parts of bolted members shall be pinned or bolted and rigidly held together during assembly. Riveted member shall have all parts firmly drawn and held together before and during riveting. Welding shall be carried out in such a way to minimize distortion and residual stress and that the final dimensions are within appropriate tolerances. Detailed to guidance on assembly is included in the standard.

#### **XVI. ANALYSIS AND DESIGN METHODS ( see Annex A)**

Detailed Annexure giving methodology for advanced structural analysis and design is included in the standard. The annexure covers second order elastic analysis and design and frame instability analysis.

#### **XVII. DESIGN AGAINST FLOOR VIBRATION ( see Annex B)**

Floor with longer spans of lighter construction and less inherent damping are vulnerable to vibrations under normal human activity. Open web steel joists (trusses) or steel beams on the concrete deck may experience walking vibration problem. Standard covers criteria for design against floor vibration.

#### **XVIII. CONNECTIONS ( see Annex E)**

A separate Annexure covers the requirement for the design of splice and beam to column connection as well as recommendation for their design.

Requirements for beam splices, column splices (simple connections, rigid connections, semi-rigid connections), column bases are covered in detail.



**CHAPTER VII**  
**EARTHQUAKE RESISTANT**  
**DESIGN**



# CHAPTER VII

## EARTHQUAKE RESISTANT DESIGN

### INTRODUCTION

This section covers earthquake resistant design and detailing of steel buildings.

In earthquake-prone regions of India, it's crucial to design buildings and structures that can withstand seismic activity. **IS 18168** ensures structures are equipped to endure strong earthquake shaking, aiming to minimize damage and protect lives. While complete immunity isn't guaranteed, adherence to the standard enhances the overall safety and resilience of buildings by incorporating seismic-resistant measures into their design.

IS 18168 focuses on earthquake-resistant design for steel buildings, emphasizing the use of moment or braced frames as lateral load-resisting systems. It includes provisions detailing:

- a) Mechanical properties of steel and welding electrodes;
- b) Design considerations for beams, columns, and joints in special moment-resisting frames; and
- c) Design guidelines for braces, shear links, and joints in braced frames.

By addressing these specific aspects, the standard provides comprehensive guidance for engineers and designers to ensure the structural integrity and resilience of steel buildings against seismic forces.

This standard covers the requirements for designing and detailing of structural components and members of steel buildings, industrial structures and steel bridges designed to resist lateral effects of earthquake shaking, so as to provide them with adequate stiffness, strength and ductility to resist severe earthquake shaking without collapse.

Provisions of this standard shall be adopted in the design of the following types of steel buildings located in seismic zones III, IV or V of **IS 1893 (Part 1)**:

- a) Residential, educational and institutional buildings;
- b) Office and business buildings; and
- c) Community, utility and lifeline buildings required for disaster management activities.

The use of this standard is optional for design of steel buildings located in seismic zone II.

The provisions of this standard apply for design and detailing of steel buildings having the following structural systems:

- a) Special moment resisting frame (SMRF);
- b) Special concentrically braced frame (SCBF); and
- c) Eccentrically braced frame (EBF).

In seismic zone V, all steel buildings shall be made of EBF systems; SCBFs shall not be used. In seismic zones IV and V, SMRFs may be used in buildings of height less than 15 m.

## I. MATERIALS (see 5.2)

The provisions of this standard on earthquake resistant design of structural steel buildings are applicable for the following grades of materials:

- a) structural steel sections and plates of grades E250 (B0 or C), E275 (B0 or C), E300 (B0 or C) or E350 (B0 or C) as per IS 2062;
- b) any other equivalent grade of steel satisfying the following:
  - 1) characteristic yield stress  $f_y$  of structural steel sections and plates in which inelastic action is expected shall not exceed 350 MPa;
  - 2) structural steel shall have minimum elongation of 22 percent;
  - 3) structural steel shall have minimum charpy V-notch impact test value of 27 J at 0 °C; and 4) The ratio of the ultimate strength to the yield strength shall at least be 1.15.

For the purpose of this standard, the expected yield strength and expected ultimate strength of a member, section or connection shall be determined based on the expected yield stress and expected tensile stress. The expected yield stress and expected tensile stress of a grade of steel shall be considered to be equal to  $R_y f_y$  and  $R_y f_u$  respectively, where  $R_y$  is the ratio of the expected yield stress to the characteristic yield stress  $f_y$ , and  $R_u$  the ratio of the expected tensile stress to the characteristic tensile stress  $f_u$  of that material.

Structural sections of lateral load resisting system shall comply with the width-to-thickness requirements specified in the standard.

## II. DESIGN REQUIREMENT (see 5.4)

The general requirements for ductile design and detailing of steel buildings shall ensure that required capacity is provided to cater to the imposed demand, in terms of the following broad aspects: a) Stability;

- b) Stiffness;
- c) Strength; and
- d) Deformability and ductility.

Here, the words capacity and demand refer to all the aspects specified above. Thus, steel buildings designed and detailed as per this standard are expected to resist design earthquake hazard defined in **IS 1893 (Part 1)** without collapse.

## Loads and Load Combinations (see 5.5)

Design earthquake loads ( $EL$ ) shall be estimated and combined as per **IS 1893 (Part 1)**, along with those in Table 4 of IS 800. In addition, the following load combinations shall be considered for design of:

- a) columns in SMRFs, SCBFs and EBFs,
- b) beams in SCBFs and EBFs,
- c) braces in EBFs, and
- d) all connections which are part of structural system in steel buildings:

$$1.2 DL + \gamma_{LLL} \pm 1.0 ELm$$

$$0.9 DL \pm 1.0 ELm$$

where

$DL$  = Dead load as per IS 875 (Part 1);

$\gamma_{LL}$  = Partial safety factor for live load

= 0.25 for live load class less than or equal to 3.0 kN/m<sup>2</sup> 0.50 for live load class more than 3.0 kN/m<sup>2</sup>;

$LL$  = Imposed load as per IS 875 (Part 2);

$ELm$  = Estimated maximum equivalent earthquake force induced in the structure  
=  $\Omega EL$ ;

$\Omega$  = Overstrength factor = 2.5 for SCBFs and EBFs = 3.0 for SMRFs; and

$EL$  = Earthquake load as per **IS 1893 (Part 1)**.

### **Analysis (see 5.6)**

Structural analysis of buildings, under the action of design load combinations, shall be performed as outlined in IS 800.

### **Stability (see 5.7)**

Under the action of the design loads, a building and its components shall be stable, and overall force and moment equilibrium shall be satisfied.

### **Stiffness (see 5.8)**

Buildings shall have adequate lateral stiffness to satisfy the drift limit specified in **IS 1893 (Part 1)**, and structural members shall satisfy deflection limits specified in IS 800, unless specified otherwise in this standard.

### **Strength (see 5.9)**

Buildings, structural members and components shall have adequate strength as required by **IS 1893 (Part 1)**, IS 800, and IS 18168.

### **Deformability and Ductility (see 5.10)**

Buildings shall be considered to satisfy the requirements of deformability and ductility by conforming to the requirements of IS 18168.

### III. BEAMS (see 6)

#### Sections (see 6.1)

Only doubly-symmetric parallel flange standard rolled sections (as per IS 808) or built-up sections, with flange width to thickness ratio and web depth to thickness ratio values less than the limits specified in IS 18168, shall be used as beams. The flange to web weld in built-up beams shall be continuous.

#### Slenderness (see 6.2)

The ratio of the maximum unbraced length of the compression flange of a beam  $L_{br}$  to the radius of gyration  $r_y$  about the weaker axis of the beam cross-section shall not exceed 25 for a distance of  $2d_b$  from the end of the beam to column connection.  $L_{br}/r$  for the remaining portion of the beam shall not exceed  $0.10E/(R_y f b)$ .

#### Bracing (see 6.3)

The stiffness of bracing shall be as given below:

- a) Beams shall be restrained against rotation about their longitudinal axis at supports and at intermediate locations along the length of the beam through the use of internal panel bracing without any external rigid support;
- b) The lateral bracing shall be attached at or near the compression flange of the beam; and
- c) The lateral bracing shall be attached at or near both flanges, near the point of inflection in beams bending in double curvature.

#### Strength (see 6.4)

The design strength of beam shall satisfy the load combinations in **IS 1893 (Part 1)**, and the over strength load combinations specified in IS 18168 in SCBFs and EBFs, or when a beam is part of diaphragm collector or chord. The design shear strength of the beam at the location of the plastic hinge shall be determined as per IS 800, and it shall be at least equal to the shear demand specified in IS 18168.

#### Splice (see 6.5)

Beam splices shall be located at least  $3d_b$  away from the face of the column or  $d_b$  from the line of action of any concentrated force acting on the beam. The design strength of beam splices shall at least be 1.80 times the required strength, except at beam-column connections. Further, design strength of each flange splice plate shall at least be  $1.2R_y f A_f$ , where  $A_f$  is the area of the flange being spliced.

### IV. COLUMNS (see 7)

#### Sections (see 7.1)

Only doubly-symmetric parallel flange standard rolled as per IS 808 or built-up sections, with flange width to thickness ratio, and web depth to thickness ratio less than the corresponding limits specified in IS 18168, shall be used as columns. The flange to web weld in built-up beams shall be continuous. **Slenderness** (see 7.2)

The slenderness ratio of unbraced length of columns shall be less than 75.

### **Bracing (see 7.3)**

Columns shall be laterally braced at supports and at intermediate locations along the length of the column through the use of internal panel bracing without any external rigid support.

### **Strength (see 7.4)**

Columns shall have design strength more than the maximum demand arising from the following:

- a) Structural analysis based on load combinations specified in IS 18168; and
- b) Maximum loads transferred to the column considering 1.2 times the strength of the connected members (beams, braces, etc) determined considering material strength uncertainty factor.

### **Splice (see 7.5)**

Column splices shall be located in the middle third of the height of the columns, at least 1.0 m away from the beam-to-column moment connection. The design strength demand of column splices shall at least be that determined using IS 18168. Further, the design strength of both flange and web splice plates shall at least be  $1.25R_y$  times of their respective strengths.

## **Connecting Codes to Classrooms: A Guide to Steel Structures Design**

### **V. BEAM-COLUMN JOINT (see 8)**

At a beam-column joint, the following design aspects shall be addressed:

- a) Column to beam strength ratio,
- b) Joint panel zone design, and
- c) Beam-column connection design.

#### **Basis of Design (see 8.1)**

Flexural plastic hinges are expected to be formed at the end regions of the beams away from the column face. Under this condition, the column and the beam-column joint, including the beam-column connection, is expected to remain elastic and shall be designed as capacity protected elements.

#### **Column to Beam Strength Ratio (see 8.2)**

At a beam-column joint, the following strength ratio as given in IS 18168 shall be satisfied.

#### **Joint Panel Zone (see 8.3)**

Shear yielding of joint panel zone (JPZ) shall be limited. Use of continuity and doubler plates is permitted.

#### **Beam-Column Connection (see 8.4)**

Fully-restrained, reinforced beam-column connections shall be used in moment frames,

capable of transferring at least a bending moment of  $1.1R_y f_y Z_{pb}$ , and shear demand determined based on capacity design principle considering, (a) beams bending in double curvature, (b) plastic hinges of strength  $1.15R_y f_y Z_{pb}$  assumed to act at a distance  $db/2$  from the end of the connection, and (c) gravity load required to be carried.

## VI. COLUMN BASE (*see* 9)

Column bases may have any form of embedded connection or anchor bolted base plate connection. The degree of fixity offered by a connection should be established and used in structural analysis.

### Anchor Bolted Base Plate Connection (*see* 9.1)

Anchor bolted base plate connections at column bases shall be designed to prevent the following:

- a) Bearing failure of concrete under compression,
- b) Pullout cone failure of concrete due to tensile force in anchor bolts,
- c) Side face blowout failure of concrete due to tensile force in anchor bolts with headed or hooked ends,
- d) Wedge-cone failure of concrete due to shear force in anchor bolts,
- e) Pryout cone failure of concrete due to shear force in anchor bolts, and
- f) Bolt-concrete bond slip failure.

### Strength (*see* 9.2)

The required design strength of the steel elements at the column base, including base plate, anchor bolts, stiffening plates, and shear lug elements shall be determined for the load combinations given in IS 18168.

### Fixed Column Base (*see* 9.3)

Fixed column base connections and supporting foundation shall be designed to resist moment demand of  $1.1R_y M_{pc}$  and shear demand equal to  $2.2R_y M_{pc}/H$  where  $M_{pc}$  and  $H_c$  are the plastic moment capacity and the clear height of the column between the connections, respectively.

### Pinned Column Base (*see* 9.4)

In lieu of detailed calculations establishing rotational stiffness (based on the degree of fixity) and bending moment strength characteristics, it is permitted to analyse and design anchor bolted base plate connections at column bases in buildings as pinned connection. In such cases, the connection and supporting foundation shall be designed for minimum moment of  $0.5R_y M_{yc}$ , where  $M_{yc}$  is the yield moment capacity of the column section, in addition to shear force demand equal to  $1.1R_y M_{pc}/H_c$ .

## VII. STRUCTURAL BRACES (*see* 10)

Structural braces may be used to impart lateral stiffness and strength to building frames. Such braces shall be provided in selected bays over the full height of the building frame. Braces part of concentrically braced frames (CBF) shall also conform to the requirements given hereunder.

### **Sections (see 10.1)**

Standard rolled or built-up sections or closed box sections, with flange width to thickness ratio and web depth to thickness ratio less than the limits specified in IS 18168, shall be used as braces. The weld between the elements of built up section shall be continuous.

### **Slenderness (see 10.2)**

The effective slenderness ratio of braces shall be less than 160. In case of built-up braces, at least two connectors shall be provided at uniform spacing such that the slenderness ratio of individual plate elements between the connectors shall be less than 0.4 times the governing effective slenderness ratio of the built-up brace.

### **Effective Area (see 10.3)**

Brace effective net area shall not be taken less than the gross cross-sectional area of the brace. Where reinforcement on braces is used, the following requirements shall apply:

- a) The characteristic yield strength of the reinforcement, when provided in the form of steel plates, shall be at least equal to the characteristic yield strength of the brace, and
- b) The connections of the reinforcement to the brace shall have sufficient strength to develop the expected reinforcement strength.

### **Bracing Connection (see 10.4)**

The required strength in tension, compression, and flexure of brace connections (including beam-to-column connections, if part of the braced-frame system) shall be determined as required in the following. These required strengths are permitted to be considered independently without interaction.

## **VIII. SHEAR LINKS (see 11)**

Shear links may be used as structural fuse in eccentrically braced frames (EBF) as specified in this standard. These links are expected to be subjected to combined action of bending moment and shear force and undergo yielding under earthquake effects.

### **Sections (see 11.1)**

Links shall be I-shaped cross sections (standard rolled wide-flange sections or built-up sections), or built-up box sections, with flange width to thickness ratio and web depth to thickness ratio less than the limits specified in the standard. Hollow structural steel (HSS) sections shall not be used as links. Further:

- a) The web or webs of a link shall be single thickness. Doubler-plate reinforcement and web penetrations are not permitted;
- b) For links made of built-up cross sections, complete-joint-penetration groove welds shall be used to connect the web (or webs) to the flanges; and
- c) Links of built-up box sections shall have a moment of inertia,  $I_y$ , about an axis in the plane of the EBF greater than  $0.67I_x$ , where  $I_x$  is the moment of inertia of the link about an axis perpendicular to the plane of the EBF.

### **Stiffeners for I-Shaped Link Sections (see 11.4)**

Web of links shall be stiffened to prevent premature buckling. The required strength of fillet welds connecting a stiffener to the link web shall be  $f_y A_{st}$ , where  $A_{st}$  is the horizontal cross-sectional area of the link stiffener. The required strength of fillet welds connecting the stiffener to the link flanges is  $f_y A_{st} / 4$ .

### **Stiffeners for Box Link Sections (see 11.5)**

Web of links shall be stiffened to prevent premature buckling. The required strength of fillet welds connecting a stiffener to the link web shall be  $f_y A_{st}$ , where  $A_{st}$  is the horizontal cross-sectional area of the link stiffener.

## **IX. SPECIAL REQUIREMENTS FOR STRUCTURAL SYSTEMS (see 12)**

Special requirements of special moment resisting frame (SMRF), special concentrically braced frame (SCBF), and eccentrically braced frame (EBF), designed as lateral load resisting system in buildings, are provided hereunder.

### **Special Moment Resisting Frames (see 12.1)**

Special moment resisting frames (SMRFs) of structural steel shall be designed to satisfy the requirements of this section.

#### **Analysis**

It is preferable to plan buildings to have independent planar lateral load resisting moment frames in each principal plan directions. In such cases, there are no special analysis requirements. But when two moment frames oriented in orthogonal directions intersect, the possibility of beam yielding in both orthogonal directions simultaneously shall be considered in the design of the common column.

#### **System Requirements**

The requirements for beams, beam column connections, column to beam strength ratio have been specified.

### **Special Concentrically Braced Frames (see 12.2)**

Special concentrically braced frames (SCBF) of structural steel shall be designed to satisfy the requirements given hereunder. Collector beams that connect SCBF braces shall be considered to be part of SCBF. Requirements for basis of design, analysis, system requirements, member requirements have been specified.

### **Eccentrically Braced Frames (see 12.3)**

Eccentrically braced frames (EBF) of structural steel shall be designed to satisfy the requirements given in IS 18168. Requirements for basis of design, analysis, system requirements, member requirements have been specified.



**CHAPTER VIII**  
**ANNEX A ABOUT BUREAU OF**  
**INDIAN STANDARDS (BIS)**

## CHAPTER VIII

### ANNEX A ABOUT BUREAU OF INDIAN STANDARDS (BIS)

In the twilight years of British rule in India, when the country was faced with the gigantic task of building up the industrial infrastructure, it was the Institution of Engineers (India), which prepared the first draft of the Constitution of an Institution which could take up the task of formulation of National Standards. This led to the Department of Industries and Supplies issuing a memorandum on 03 September 1946, formally announcing the setting of an organization called the “Indian Standards Institution”. The Indian Standards Institution (ISI) came into being on the 06 January 1947.

Bureau of Indian standards (BIS) came into existence, through an act of parliament dated 26 November 1986, on 1 April 1987, with a broadened scope and more powers taking over the staff, assets, liabilities and functions of erstwhile ISI. Through this change over, the government envisaged building a climate for quality culture and consciousness and greater participation of consumers in formulation and implementation of national standards.

Bureau of Indian Standards Act, 2016 that was notified on 22 March 2016, further enlarges the scope of activities of BIS in respect to standardization and certification of goods, articles, processes, systems and services.

#### I. STANDARDS FORMULATION ACTIVITY IN BIS

Formulation of Indian Standards is one of the core activities of BIS. The activity is done through 16 Division Councils representing diverse areas of economy and technology, as follows:

Ayush	Management and Systems
Chemical	Mechanical Engineering
Civil Engineering	Petroleum, Coal and Related Products
Electrotechnical	Production and General Engineering
Electronics and Information Technology	Services Sector
Food and Agriculture	Textile
Medical Equipment And Hospital Planning	Transport Engineering
Metallurgical Engineering	Water Resources

Indian Standards are formulated through dedicated technical committees functioning under the Division Councils, namely, Sectional Committees, which may be supported by other technical committees like subcommittees and panels set up to deal with specific group of subjects. The committee structure is designed such as to bring together all those with substantial interest in a particular field, so that standards are developed

keeping in view the balance of interests among the relevant stakeholders like manufacturers, users, technologists and regulators and after taking into account all significant viewpoints through a process of wide consultation. Decisions in BIS technical committees are reached through consensus.

## II. STANDARDS DEVELOPMENT PROCESS AT BIS

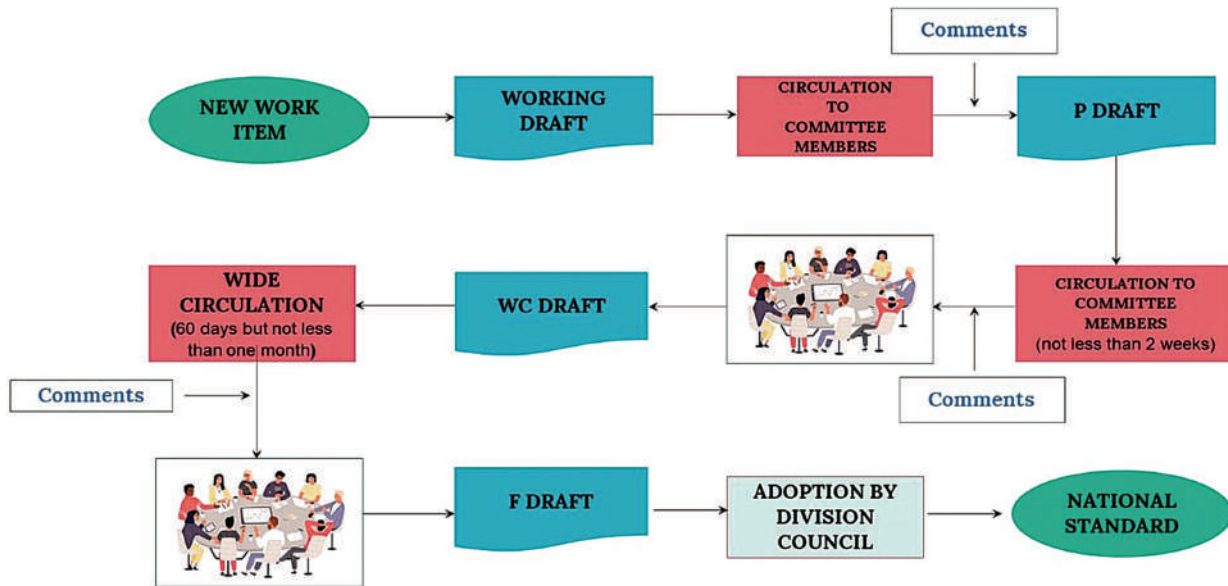

## III. COMMENTING ON DRAFT STANDARDS

The standards, both Indian as well as International invite comments on the published as well as drafts under preparation. The procedure to comment on the Indian as well as ISO standards is detailed below:

Academia is one of the important stakeholders in BIS's standard formulation process, and we encourage Academia to look upon our standards (published and draft standards) and enrich the Indian Standards by examining those through a holistic perspective.

### A. Commenting on Draft Indian Standards under Wide Circulation

One can access the draft Indian Standards that are under Wide Circulation stage, and submit any observations/comments for consideration of the concerned Sectional Committee.

*Steps*

Go to BIS website (<https://www.bis.gov.in/>) and select Wide Circulation Drafts in the drop-down menu under the Standards tab.

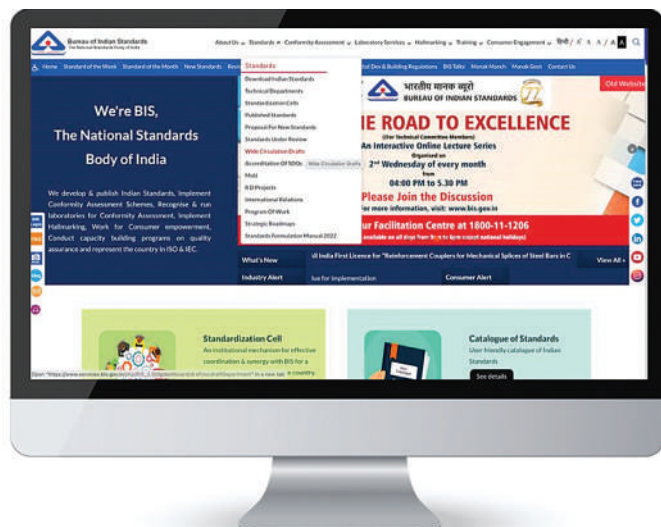

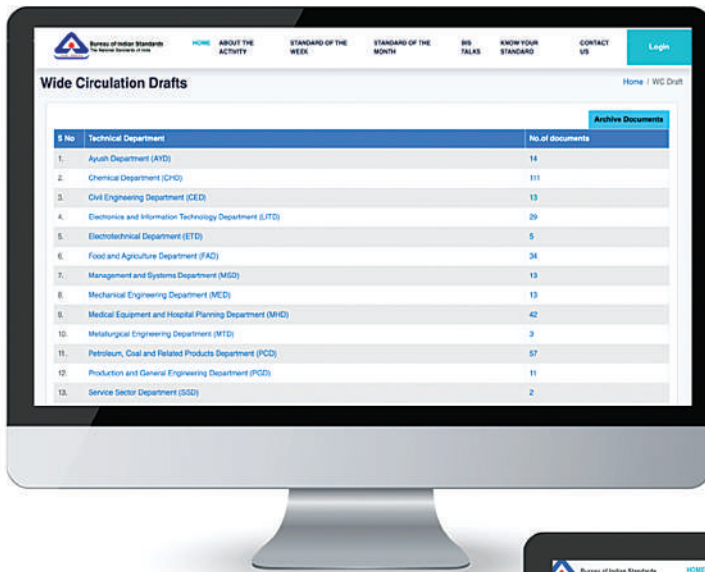

Click on the corresponding figure under the column No. of Documents against Civil Engineering Department

On the web -page, one may download the draft of any draft Indian Standard under WC stage, or submit comments.

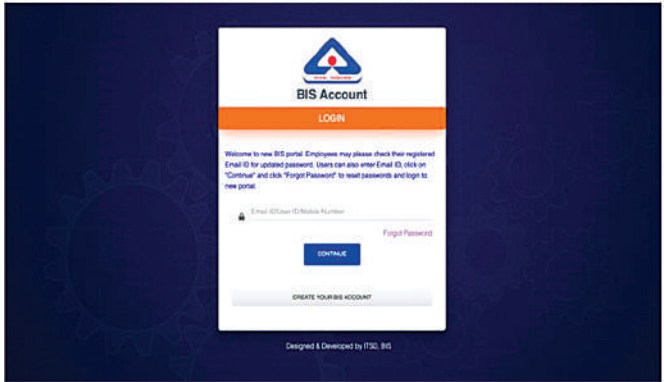
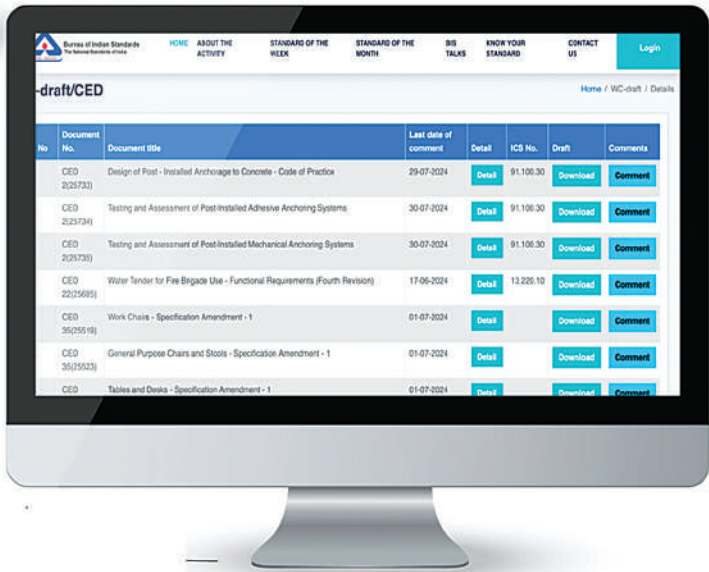

## Connecting Codes to Classrooms: A Guide to Steel Structures Design



For submitting comments, one needs to sign in using an existing login id, or sign up using any email address.

The comments are then referred to the concerned Sectional Committee, which examines the merit of a comment and takes a decision on acceptance of the comment accordingly.

### B. Commenting on Draft International Standards

While the draft International Standards under development at ISO are not publicly available, the draft standards are circulated among the members of the concerned BIS Sectional Committee for examination and comments.

The comments received are then taken up with the Committee, and the duly approved comments are submitted to ISO as the viewpoint of the National Standards Body.

However, the work programme of any ISO Technical Committee (TC or SC) is available publicly, and can be viewed by visiting the web-page of a concerned TC/SC, and clicking on the figure corresponding to the tile 'Published ISO standards'.

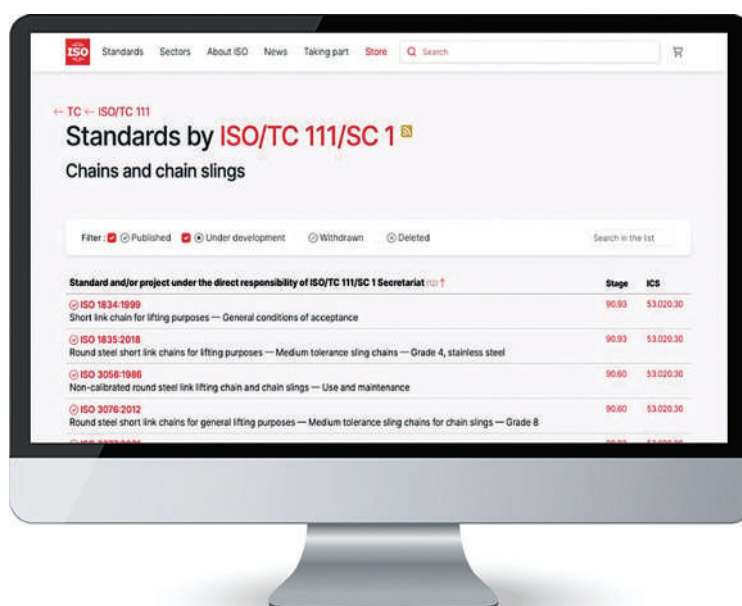

## ANNEX B

### SOME INITIATIVES BY BIS FOR COLLABORATION WITH ACADEMIC INSTITUTIONS

#### I. CREATION OF BIS STANDARDIZATION CHAIRS IN PREMIER TECHNICAL INSTITUTIONS

BIS has signed Memorandum of Understanding (MoU) with Premier Technical Institutions of the country to develop collaborative activities in the field of Standardization and Conformity Assessment on the basis of equality and reciprocity by appointing a Chair in the field of Standardization and Conformity Assessment. The creation of a BIS Standardization Chair is for research & development, teaching and training in the field of Standardization and Conformity Assessment in the country with focus on the areas of civil, electrical, mechanical, chemical, earthquake engineering, development and management of water resources and renewable energy projects, infrastructure development, medical biotechnology & nanotechnology, biomaterials, etc. (as mutually agreed).

#### II. BIS INTERNSHIP SCHEME

Bureau of Indian Standards, the National Standards Body of India, seeks to engage students (Undergraduate and above) as “Interns”, who would be given exposure to various activities of BIS. The Interns would be expected to supplement the knowledge capital of BIS through collection, collation and analysis of data in respect of standardization, conformity assessment, testing, consumer engagement and stakeholder expectations. The Scheme is envisaged to be mutually beneficial to students and BIS. BIS would benefit in the form of getting fresh thoughts, perspectives and updated technical knowledge from the young generation. For the “Interns”, the exposure to the functioning of BIS and understanding of quality ecosystem, which would be an add-on in furthering their own career goals in the Industries or International Organizations.

#### III. EDUCATION OUTREACH PROGRAMME AND FACULTY SENSITIZATION WORKSHOP

Through this programme, BIS aims at expanding the folds of standardization ecosystems to the academic institutions and its faculties through their participation in standardization activity through Technical Committees of the Bureau at National and International level, by undertaking R&D projects related to standardization and conformity assessment, by developing infrastructure support for R&D projects of relevance to standardization at the institutions, by introducing topics on standardization in academic syllabus, by organizing training and shortterm education programmes on standardization, etc.

#### IV. R&D PROJECTS

As a matter of policy, no new standard should be formulated or existing standard reviewed without an Action Research Project or R&D project, unless the SC takes a conscious call, to be recorded in the minutes of the SC meeting, that the data and information available is sufficient and does not warrant any further research. As per the guidelines for R&D projects approved by the Executive

committee of BIS, small R&D projects (with financial involvement up to Rs 10 lakh only) can be awarded to the members of SC, WP, working groups and faculty or research scholars of the academic institutions having entered into MoU with BIS by inviting proposals from them.

## **V. STANDARD CLUBS**

Recognizing the significance of instilling the importance of standards in young minds, BIS has launched the Standards Clubs initiative in 2021, which has already made a significant impact on schools and colleges across the country. By establishing these clubs in different schools and colleges across the country, BIS aims to engage and educate young talents about the importance of quality, standards, and fostering a scientific temperament.

### **Connecting Codes to Classrooms: A Guide to Steel Structures Design**

## **VI. LET US TALK ABOUT STANDARDS**

To take the initiative of Education Outreach forward, BIS has launched a lecture series named 'Let us Talk about Standards'. The objective of the lecture series is dissemination of information about the Standardization process and discussing the department wise research projects hosted on the BIS website.

## **VII. MANAK MANTHAN**

The Manak Manthan programme is an initiative by the Bureau of Indian Standards (BIS), aimed at engaging various stakeholders in the process of standardization and enhancing the relevance and impact of standards in India. This programme is part of BIS's broader mission to promote standardization, quality assurance, and conformity assessment activities to enhance the economic and industrial development of the country.

For more details, kindly access the links:

[https://www.services.bis.gov.in/php/BIS\\_2.0/eBIS/](https://www.services.bis.gov.in/php/BIS_2.0/eBIS/); <https://www.bis.gov.in>

## ANNEX C

### OVERVIEW OF CIVIL ENGINEERING DEPARTMENT, BUREAU OF INDIAN STANDARDS

#### I. DISTRIBUTION OF CIVIL ENGINEERING STANDARDS

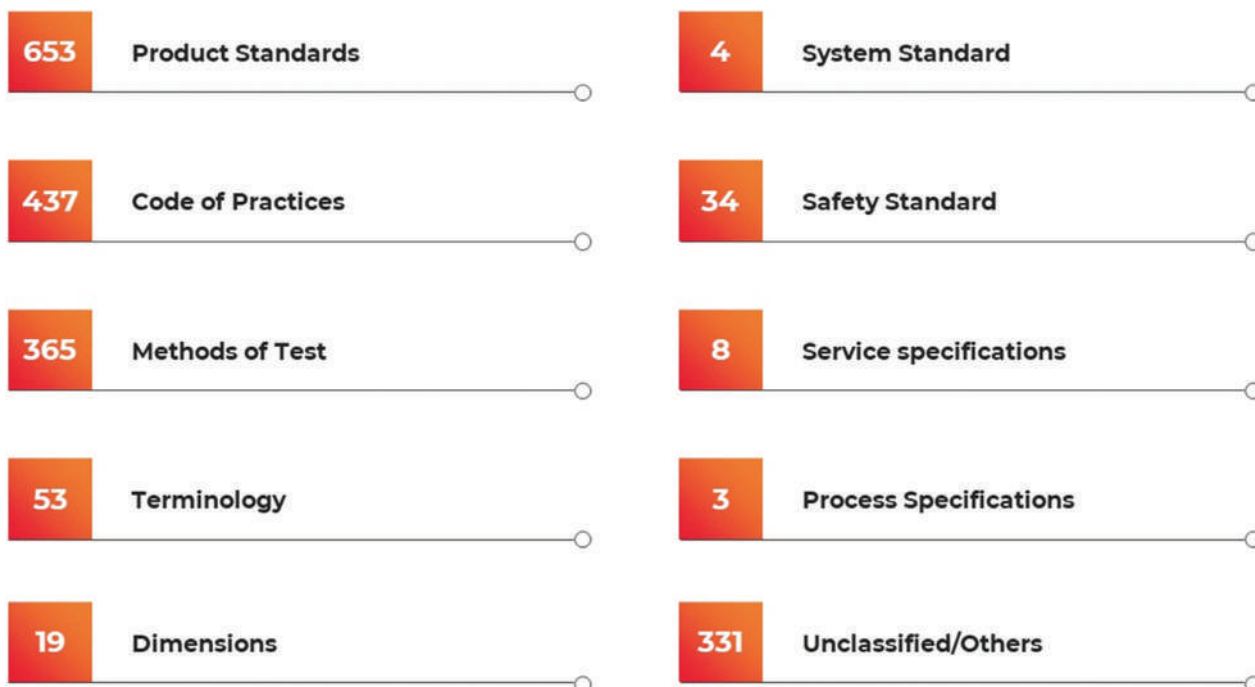

#### II. TECHNICAL COMMITTEES UNDER CIVIL ENGINEERING DEPARTMENT

Sl No.	Technical Committee	Technical Committee Name
1	CED 02	Cement and Concrete Sectional Committee
2	CED 03	Sanitary Appliances and Water Fittings Sectional Committee
3	CED 04	Building Limes and Gypsum Products Sectional Committee
4	CED 05	Flooring, Wall Finishing and Roofing Sectional Committee
5	CED 06	Stones Sectional Committee
6	CED 07	Structural Engineering and Structural Sections Sectional Committee
7	CED 09	Timber and Timber Stores Sectional Committee
8	CED 11	Doors, Windows and Shutter Sectional Committee
9	CED 12	Functional Requirements in Buildings Sectional Committee
10	CED 13	Building Construction Practices Sectional Committee
11	CED 15	Builder's Hardware Sectional Committee
12	CED 20	Wood and Other Lignocellulosic Products Sectional Committee
13	CED 22	Fire Fighting Sectional Committee



14	CED 24	Public Health Engineering. Sectional Committee
15	CED 29	Construction Management Sectional Committee
16	CED 30	Clay and Stabilized Soil Products for Construction Sectional Committee
17	CED 32	Prefabricated Construction Sectional Committee
18	CED 35	Furniture Sectional Committee
19	CED 36	Fire Safety Sectional Committee
20	CED 37	Structural Safety Sectional Committee
21	CED 38	Special Structures Sectional Committee
22	CED 39	Earthquake Engineering Sectional Committee
23	CED 41	Waterproofing and Damp-proofing Sectional Committee
24	CED 43	Soil and Foundation Engineering Sectional Committee
25	CED 44	Methods of Measurement of Works of Civil Engineering Sectional Committee
26	CED 45	Safety in Construction Sectional Committee
27	CED 46	National Building Code Sectional Committee
28	CED 47	Ports and Harbours Sectional Committee
29	CED 48	Rock Mechanics Sectional Committee
30	CED 50	Plastic Piping System Sectional Committee
31	CED 51	Planning and Housing Sectional Committee
32	CED 53	Cement Matrix Products Sectional Committee
33	CED 54	Concrete Reinforcement Sectional Committee
34	CED 55	Sieves, Sieving and other Sizing Methods Sectional Committee
35	CED 56	Hill Area Development Engineering Sectional Committee
36	CED 57	Cyclone Resistant Structure Sectional Committee
37	CED 58	Sustainability in Building Construction Sectional Committee
38	CED 59	Smart Cities Sectional Committee

## ANNEX D

### CED 07- STRUCTURAL ENGINEERING AND STRUCTURAL SECTIONS SECTIONAL COMMITTEE

The Committee deals with standardization in the field of structural engineering using steel/aluminium structural sections including pipelines for gas and formulation of Indian standards on dimensions/tolerances of various hot rolled/cold formed sections, bars and flat products in steel and aluminium for structural and general engineering applications.

The Committee is also Liasoning with ISO/TC 167 - Steel and aluminium structures as participating (P) member.

#### I. STANDARDS PUBLISHED BY CED 07 SECTIONAL COMMITTEE

IS No.	Title
IS 800 : 2007	General construction in steel — Code of practice
IS 801 : 1975	Code of practice for use of cold — Formed light gauge steel structural members in general building construction
IS 802 (Part 1/ Sec 1) : 2015	Use of structural steel in overhead transmission line towers — Code of practice: Part 1 materials loads and design strengths, Section 1 Materials and loads
IS 802 (Part 1/ Sec 2) : 2016	Use of structural steel in overhead transmission line towers — Code of practice: Part 1 Material loads and permissible stresses, Section 2 Permissible stresses
IS 802 (Part 2) : 1978	Code of practice for use of structural steel in overhead transmission line towers: Part 2 Fabrication galvanizing inspection and packing
IS 802 (Part 3) : 1978	Code of practice for use of structural steel in overhead transmission line towers: Part 3 Testing
IS 802 (Part 4) : 2023	Use of structural steel in overhead transmission line towers code of practice: Part 4 Requirements for latticed switchyard structures
IS 802 (Part 6) : 2022	Code of practice for use of structural steel in overhead transmission line towers: Part 6 Tower erection
IS 803 : 1976	Code of practice for design fabrication and erection of vertical mild steel cylindrical welded oil storage tanks
IS 804 : 1967	Specification for rectangular pressed steel tanks
IS 805 : 1968	Code of practice for use of steel in gravity water tanks
IS 806 : 1968	Code of practice for use of steel tubes in general building construction
IS 808 : 2021	Hot rolled steel beam column channel and angle sections — Dimensions and Properties

<b>IS No.</b>	<b>Title</b>
IS 811 : 1987	Specification for cold formed light gauge structural steel sections
IS 1173 : 1978	Hot rolled and slit steel tee bars
IS 1252 : 1991	Hot rolled steel bulb angles dimensions
IS 1730 : 1989	Dimensions for steel plates sheets strips and flats for general engineering purposes
IS 1732 : 1989	Steel Bars round and square for structural and general engineering purposes
IS 1863 : 1979 ISO 657-19	Rolled steel bulb flats
IS 1864 : 1979/ ISO 657-18	Specification for hot rolled steel 39 L 39 sections for ship building
IS 2314 : 1986	Steel sheet piling sections
IS 2314 (Part 1) : 2023	Steel sheet piling section specification: Part 1 Hot rolled sheet pile
IS 2314 (Part 2) : 2023	Steel sheet piling section specification: Part 2 Cold formed sheet pile
IS 2713 (Part 13) : 1980	Tubular steel poles for overhead power lines
IS 2750 : 1964	Specification for steel scaffoldings
IS 3443 : 1980	Crane rail sections
IS 3908 : 1986	Aluminium equal leg angles
IS 3909 : 1986	Aluminium unequal leg angles
IS 3921 : 1985	Aluminium channels
IS 3954 : 1991	Hot rolled steel channel sections for general engineering purposes — Dimensions
IS 3964 : 1980	Light rails
IS 4000 : 1992	High strength bolts in steel structures — Code of practice
IS 4014 (Part 1) : 1967	Code of practice for steel tubular scaffolding: Part 1 Definitions and materials
IS 5384 : 1985	Aluminium I-beam
IS 5488 : 1987	Dimensions and dimensional tolerances for hot rolled steel plates for ships hull structure
IS 6445 : 1985	Specification for aluminium Tee-sections
IS 6449 : 1987	Specification for aluminium bulb angles for marine application
IS 6475 : 1987	Specification for aluminium tee bars for marine application

<b>IS No.</b>	<b>Title</b>
IS 6476 : 1987	Specification for aluminium bulb plates for marine application
IS 6533 (Part 1) : 1989	Code of practice for design and construction of steel chimneys: Part 1 Mechanical aspects
IS 6533 (Part 2) : 1989	Code of practice for design and construction of steel chimneys: Part 2 Structural aspects
IS 7205 : 1974	Safety code for erection of structural steel work
IS 7215 : 1974	Tolerances for fabrication of steel structures
IS 7452 : 1990	Hot rolled steel sections for doors windows and ventilators — Specification
IS 8081 : 1976	Specification for slotted sections
IS 8147 : 1976	Code of practice for use of aluminium alloys in structures
IS 8640 : 1977	Recommendations for dimensional parameters for industrial buildings
IS 9178 (Part 1) : 1979	Criteria for design of steel bins for storage of bulk materials: Part 1 General requirements and assessment of loads
IS 9178 (Part 2) : 1979	Criteria for design of steel bins for storage of bulk materials: Part 2 Design criteria
IS 9178 (Part 3) : 1980	Criteria for design of steel bins for storage of bulk materials — Part 3 Bins designed for mass flow and funnel flow
IS 9964 (Part 1) : 1981	Recommendations for maintenance and operation of petroleum storage tanks: Part 1 preparation of tank for safe entry and work
IS 9964 (Part 2) : 1981	Recommendations for maintenance and operation of petroleum storage tanks: Part 2 inspection
IS 10182 (Part 1) : 1982	Dimensions and tolerances for hot rolled track shoe sections: Part 1 Sec TS-L1
IS 10182 (Part 2) : 1985	Dimensions and tolerances for hot rolled track shoe sections Part 2 Sec TS-H1
IS 10987 : 1982	Code of practice for design fabrication testing and installation of under — Ground above — Ground horizontal cylindrical steel storage tanks for petroleum products
IS 12778 : 2004	Hot rolled parallel flange steel sections for beams columns and bearing piles — Dimensions and section properties
IS 12779 : 1989	Rolling and cutting tolerances for hot rolled parallel flange beam and column sections — Specification
IS 12843 : 1989	Tolerances for erection of steel structures
IS 15663 (Part 1) : 2006	Design and installation of natural gas pipelines — Code of

<b>IS No.</b>	<b>Title</b>
	practice: Part 1 Laying of pipelines
IS 15663 (Part 2) : 2006	Design and installation of natural gas pipelines — Code of practice: Part 2 Laying of pipelines in crossings
IS 15663 (Part 3) : 2006	Design and installation of natural gas pipelines — Code of Practice: Part 3 Pre-commissioning and commissioning of pipelines
IS 17740 : 2022	Isolated towers masts and poles using structural steel — Code of practice
SP 6-4 : 1969	ISI handbook for structural engineers: Part 4 Use of high strength friction grip bolts
SP 6-5 : 1980	Handbook for structural engineers: Part 5 Cold-formed light gauge steel structures
SP 6-6 : 1972	ISI handbook for structural engineers: Part 6 Application of plastic theory in design of steel structures sec A

**ANNEX E**

**INDIAN STANDARDS RELATED TO STRUCTURAL STEEL  
(METALLURGICAL ENGINEERING DEPARTMENT)**

<b>Sl No.</b>	<b>IS No.</b>	<b>IS Title</b>	<b>Technical Committee</b>	<b>Aspect</b>
1	IS 228 (Part 1) : 1987	Methods for chemical analysis of steels: Part 1 Determination of carbon by volumetric method (for carbon 0.05 to 2.50 percent)	MTD 34	Methods of Tests
2	IS 228 (Part 2) : 1987	Methods for chemical analysis of steels: Part 2 Determination of manganese in plain-carbon and low alloy steels by arsenite method	MTD 34	Methods of Tests
3	IS 228 (Part 3) : 1987	Methods for chemical analysis of steels: Part 3 Determination of phosphorus by alkalimetric method	MTD 34	Methods of Tests
4	IS 228 (Part 4) : 1987	Methods for chemical analysis of steels: Part 4 Determination of total carbon by gravimetric method (for carbon 0.1 percent)	MTD 34	Methods of Tests
5	IS 228 (Part 5) : 1987	Methods for chemical analysis of steels: Part 5 Determination of nickel by dimethylglyoxime (gravimetric) method (for nickel 0.1 percent)	MTD 34	Methods of Tests
6	IS 228 (Part 7) : 1990	Methods for chemical analysis of steels: Part 7 Determination of molybdenum by alpha-benzoinoxime method in alloy steels (for molybdenum > 1 percent and not containing tungsten)	MTD 34	Methods of Tests
7	IS 228 (Part 8) : 1989	Methods for chemical analysis of steels: Part 8 Determination of silicon by the gravimetric method (for silicon 0.05 to 5.00 percent)	MTD 34	Methods of Tests
8	IS 228 (Part 9) : 1989	Methods for chemical analysis of steels: Part 9 Determination of sulphur by evolution method (for sulphur 0.01 to 0.25 percent)	MTD 34	Methods of Tests
9	IS 228 (Part 10) : 1989	Methods for chemical analysis of steels: Part 10 Determination of molybdenum by thiocyanate (photometric) method in low and high alloy steels (for molybdenum 0.01 to 1.50 percent)	MTD 34	Methods of Tests
10	IS 228 (Part 11) : 1989	Methods for chemical analysis of steels: Part 11 Determination of total silicon by reduced molybdo-silicate spectrophotometric method in carbon steels and low alloy steels (for silicon 0.01 to 0.05 percent)	MTD 34	Methods of Tests

<b>Sl No.</b>	<b>IS No.</b>	<b>IS Title</b>	<b>Technical Committee</b>	<b>Aspect</b>
11	IS 228 (Part 12) : 1989	Methods for chemical analysis of steels: Part 12 Determination of manganese by periodate spectrophotometric method in plain carbon, low alloy and high alloy steels (for manganese 0.01 to 5.0 percent)	MTD 34	Methods of Tests
12	IS 228 (Part 14) : 1989	Methods for chemical analysis of steels: Part 14 Determination of carbon by thermal conductivity method (for carbon 0.005 to 2.000 percent)	MTD 34	Methods of Tests
13	IS 228 (Part 17) : 1998	Methods for chemical analysis of steels: Part 17 Determination of nitrogen by thermal conductivity method (for nitrogen up to 0.04 percent)	MTD 34	Methods of Tests
14	IS 228 (Part 18) : 1998	Methods for chemical analysis of steels: Part 18 Determination of oxygen by instrumental method (for oxygen 0.001 to 0.100 0 percent)	MTD 34	Methods of Tests
15	IS 228 (Part 19) : 1998	Methods for chemical analysis of steels: Part 19 Determination of nitrogen by steam distillation method (for nitrogen 0.002 to 0.50 percent)	MTD 34	Methods of Tests
16	IS 228 (Part 20) : 1989	Methods of chemical analysis of steel: Part 20 Determination of total carbon and sulfur content — Infrared absorption method after combustion in an induction furnace (routine method)	MTD 34	Methods of Tests
17	IS 513 (Part 1) : 2016	Cold reduced carbon steel sheet and strip: Part 1 Cold forming and drawing purpose	MTD 04	Product Specification
18	IS 816 : 1969	Code of practice for use of metal arc welding for general construction in mild steel	MTD 11	Code of Practice
19	IS 817 (Part 1) : 1992	Training of welders — Code of practice: Part 1 Manual metal arc welding	MTD 11	Code of Practice
20	IS 817 (Part 2) : 1996	Training of welders — Code of practice: Part 2 Oxyfuel welding	MTD 11	Code of Practice

Sl No.	IS No.	IS Title	Technical Committee	Aspect
21	IS 1030 : 1998	Carbon steel castings for general engineering purposes — Specification	MTD 14	Product Specification
22	IS 1079 : 2017	Hot rolled carbon steel sheet, plate and strip — Specification	MTD 04	Product Specification
23	IS 1875 : 1992	Carbon steel billets, blooms, slabs and bars for forgings — Specification	MTD 04	Product Specification
24	IS 2062 : 2011	Hot rolled medium and high tensile structural steel — Specification	MTD 04	Product Specification
25	IS 2830 : 2012	Carbon steel cast billet ingots, billets, blooms and slabs for re-rolling into Steel for general structural purposes — Specification	MTD 04	Product Specification
26	IS 2831 : 2012	Carbon steel cast billet ingots, billets, blooms and slabs for re-rolling into structural steel (ordinary quality) — Specification	MTD 04	Product Specification
27	IS 3039 : 2024	Structural steel for construction of ships — Specification	MTD 04	Product Specification
28	IS 4759 : 1996	Hot-dip zinc coatings on structural steel and other allied products — Specification	MTD 24	Product Specification
29	IS 6419 : 1996	Welding rods and bare electrodes for gas shielded arc welding of structural steel — Specification	MTD 11	Product Specification
30	IS 10178 : 1995	CO <sub>2</sub> gas shielded metal — Arc welding of structural steels — Recommendations	MTD 11	Others
31	IS 15911 : 2010	Structural steel (ordinary quality) — Specification	MTD 04	Product Specification
32	IS 15962 : 2012	Structural steels for buildings and structures with improved seismic resistance	MTD 04	Product Specification
33	IS 16732 : 2019	Galvanized structural steel — Specification	MTD 04	Product Specification



## ANNEX F

### STEEL AND IRON PRODUCTS UNDER COMPULSORY CERTIFICATION OF BIS

Quality Control Orders (QCOs) are regulatory measures introduced by the Government of India to establish minimum levels of quality for products under public interest, such as protection of human, animal or plant health, safety of environment, prevention of unfair trade practices and national security.

BIS certification scheme is basically voluntary in nature. However, for a number of products, compliance to Indian Standards is made compulsory by the Central Government. For such products, the Central Government directs compulsory use of Standard Mark under a *Licence* or *Certificate of Conformity* (CoC) from BIS through issuance of QCOs. For the purpose of facilitating the Central Government in issuance of QCOs, BIS regularly interacts with line ministries/departments and provides technical inputs related to Indian Standards, appropriate Conformity Assessment Scheme etc. and also participates in stakeholder's consultation meetings.

For implementation of the provisions of QCOs, BIS acts as the Certification Authority and grants Licence or CoC to manufacturers as per relevant Conformity Assessment Scheme. BIS also acts as the Enforcement Authority for certain products specified in the QCO.

The steel and iron products under compulsory certification of BIS are as under:

Sl No.	IS No.	Products
1	IS 277 : 2003	Galvanized steel sheets (plain and corrugated)
2	IS 280 : 2006	Mild steel wire for general engineering purposes
3	IS 412 : 1975	Expanded metal steel sheets for general purposes
4	IS 432 (Part 1) : 1982	Mild steel and medium tensile steel bars and hard-drawn steel wire for concrete reinforcement: Part 1 Mild steel and medium tensile steel bars
5	IS 432 (Part 2) : 1982	Mild steel and medium tensile steel bars and hard-drawn steel wire for concrete reinforcement: Part 2 Hard-drawn steel wire
6	IS 513 (Part 1) : 2016	Cold reduced carbon steel sheets and strips: Part 1 Cold forming and drawing purpose
7	IS 513 (Part 2) : 2016	Cold reduced carbon steel sheets and strips: Part 2 High tensile and multi-phase steel
8	IS 648 : 2006	Cold rolled non-oriented electrical steel sheets and strip-fully processed type (CRNO)
9	IS 963 : 1958	Chrome molybdenum steel bars and rods for aircraft purposes
10	IS 1029 : 1970	Specification for hot rolled steel strip (bailing)
11	IS 1170 : 1992	Ferrochromium — Specification

<b>Sl No.</b>	<b>IS No.</b>	<b>Products</b>
12	IS 1079 : 2017	Hot rolled carbon steel sheet, plate and strip — Specification
13	IS 1110 : 1990	Ferrosilicon — Specification
14	IS 1148 : 2009	Steel rivet bars (medium and high tensile) — For structural purposes
15	IS 1161 : 2014	Steel tubes for structural purposes
16	IS 1171 : 2011	Ferromanganese — Specification
17	IS 1239 (Part 1) : 2014	Steel tubes, tubulars and other wrought steel fittings: Part 1 Steel tubes
18	IS 1470 : 2013	Silicomanganese — Specification
19	IS 1566 : 1982	Specification for hard-drawn steel wire fabric for concrete reinforcement
20	IS 1673 : 1984	Specification for mild steel wire, cold heading quality
21	IS 1785 (Part 1) : 1983	Plain hard-drawn steel wire for pre-stressed concrete: Part 1 Cold drawn stress-relieved wire
22	IS 1785 (Part 2) : 1983	Plain hard-drawn steel wire for pre-stressed concrete: Part 2 As drawn wire
23	IS 1786 : 2008	High strength deformed steel bars and wires for concrete reinforcement
24	IS 1812 : 1982	Specification for carbon steel wire for the manufacture of wood screws
25	IS 1835 : 1976	Round steel wire for ropes
26	IS 1875 : 1992	Carbon steel billets, blooms, slabs and bars for forgings
27	IS 1993 : 2018	Cold-reduced electrolytic tin plate
28	IS 2002 : 2009	Steel plates for pressure vessels for intermediate and high temperature service including boilers
29	IS 2041 : 2009	Steel plates for pressure vessels used at moderate and low temperature
30	IS 2062 : 2011	Hot rolled medium and high tensile structural steel
31	IS 2090 : 1983	Specification for high tensile steel bars used in pre-stressed concrete
32	IS 2100 : 1970	Steel billets, bars and sections for boilers
33	IS 2255 : 1977	Specification for mild steel wire rod for the manufacture of machine screws (by cold heading process)
34	IS 2385 : 1977	Specification for hot-rolled mild steel sheet and strip in coil form for cold-reduced tinplate and cold-reduced black plate

<b>Sl No.</b>	<b>IS No.</b>	<b>Products</b>
35	IS 2507 : 1975	Specification for cold-rolled steel strips for springs
36	IS 2589 : 1975	Hard drawn steel wire for upholstery springs
37	IS 2830 : 2012	Carbon steel cast billet ingots ,billets, blooms and slabs for rerolling into steel for general structural purpose
38	IS 2831 : 2012	Carbon steel cast billet ingots, billets, blooms and slabs for re-rolling into structural steel (ordinary quality) — Specification
39	IS 2879 : 1998	Mild steel for metal arc welding electrodes
40	IS 3024 : 2015	Grain oriented electrical steel sheet & strip (CRGO)
41	IS 3039 : 1988	Specification for Structural steel for construction of hulls of ships
42	IS 3195 : 1992	Steel for the manufacture of volute and helical springs (for railway rolling stock) — Specification
43	IS 3298 : 1981	Mild steel rivet bars for ship building
44	IS 3431 : 1982	Specification for steel for the manufacture of volute, helical and laminated springs for automotive suspension
45	IS 3502 : 2009	Steel chequered plates
46	IS 3748 : 1990	Tool and die steels — Specification
47	IS 3885 (Part 1) : 1992	Steel for the manufacture of laminated springs (railway rolling stock): Part 1 Flat sections — Specification
48	IS 3885 (Part 2) : 1992	Steel for the manufacture of laminated springs (railway rolling stock): Part 2 Rib and groove sections — Specification
49	IS 3930 : 1994	Flame and induction hardening steels
50	IS 3975 : 1999	Low carbon galvanized steel wires formed wires and tapes for armouring of cables
51	IS 4072 : 1975	Steel for spring washers
52	IS 4223 : 1975	Specification for steel wire for umbrella ribs
53	IS 4224 : 1972	Specification for steel wire for staples, pins and clips
54	IS 4270 : 2001	Steel tubes used for water-wells (upto 200 mm dia)
55	IS 4368 : 1967	Alloy steel billets, blooms and slabs for forging for general engineering purposes.
56	IS 4397 : 1999	Cold-rolled carbon steel strips for ball and roller bearing cages/ retainers — Specification
57	IS 4398 : 1994	Carbon-chromium steel for the manufacture of balls, rollers and bearing races — Specification

<b>Sl No.</b>	<b>IS No.</b>	<b>Products</b>
58	IS 4409 : 1973	Specification for ferronickel
59	IS 4431 : 1978	Carbon and carbon-manganese free-cutting steels
60	IS 4432 : 1988	Case hardening steels
61	IS 4454 (Part 1) : 2001	Steel wire for mechanical springs: Part 1 Cold drawn unalloyed steel wire
62	IS 4454 (Part 2) : 2001	Steel wire for mechanical springs: Part 2 Oil hardened and tempered steel wire
63	IS 4454 (Part 4) : 2001	Steel wires for mechanical springs: Part 4 Stainless steel wire
64	IS 4824 : 2006	Bead wires for tyres
65	IS 4882 : 1979	Specification for low carbon steel wire for rivets for use in bearing industry
66	IS 5478 : 1969	Thermostat metal sheet and strip
67	IS 5517 : 1993	Steel for hardening and tempering — Specification
68	IS 5518 : 1996	Steels for die blocks for drop forging
69	IS 5522 : 2014	Stainless Steel sheets and strips for utensils — Specification
70	IS 5651 : 1987	Steels for pneumatic tools
71	IS 5872 : 1990	Cold rolled steel strips (box strappings)
72	IS 5986 : 2017	Hot rolled steel sheet, plate and strip for forming and flanging purposes — Specification
73	IS 6003 : 2010	Indented wire for pre-stressed concrete
74	IS 6006 : 2014	Uncoated stress relieved strand for pre-stressed concrete
75	IS 6240 : 2008	Hot rolled steel plate (up to 6 mm) sheet and strip for the manufacture of low pressure liquefiable gas cylinders
76	IS 6527 : 1995	Stainless steel wire rod
77	IS 6528 : 1995	Stainless steel wires
78	IS 6529 : 1996	Stainless steel blooms billets and slabs for forging
79	IS 6902 : 1973	Specification for steel wire for spokes
80	IS 6603 : 2001	Stainless steel bars and flats
81	IS 6911 : 2017	Stainless steel plate, sheet and strip — Specification
82	IS 6967 : 1973	Specification for steel for electrically welded round link chains
83	IS 7226 : 1974	Specification for cold rolled medium, high carbon and low alloy steel strip for general engineering purposes

<b>Sl No.</b>	<b>IS No.</b>	<b>Products</b>
84	IS 7283 : 1992	Hot rolled bars for production of bright bars and machined parts for engineering applications
85	IS 7494 : 1981	Specification for steel for valves for internal combustion engines
86	IS 7557 : 1982	Specification for steel wire: (Up to 20 mm) for the manufacture of coldforged rivets
87	IS 7887 : 1992	Mild steel wire rods for general engineering purposes
88	IS 7904 : 2017	High carbon steel wire rods — Specification
89	IS 8052 : 2006	Steel ingots, billets and blooms for the production of springs, rivets and screws for general engineering applications — Specification
90	IS 8329 : 2000	Centrifugally cast (spun) ductile iron pressure pipes for water, gas and sewage
91	IS 8510 (Part 2) : 1977	Steel wire for banding of armatures and rotors: Part 2 Specific Requirements for magnetic banding wires
92	IS 8510 (Part 3) : 1977	Tinned steel wire for banding of armatures and rotors: Part 3 Specific requirements for non-magnetic banding wires
93	IS 8563 : 1977	Half round mild steel wire for the manufacture of split pins
94	IS 8564 : 1977	Steel wire for nipples for spokes
95	IS 8565 : 1977	Specification for Heald wire
96	IS 8566 : 1977	Steel wire for reeds
97	IS 8748: 1978	Forged/rolled CTC segments
98	IS 8951 : 2001	Steel cast billet ingots, billets and blooms for production of high carbon steel wire rods — Specification
99	IS 8952 : 1995	Steel ingots, blooms and billets for production of mild steel wire rods for general engineering purposes — Specification
100	IS 8917 : 1978	Plates for galvanizing pots
101	IS 9139 : 1979	Specification for malleable iron shots and grits for use in foundries
102	IS 9294 : 1979	Cold-rolled stainless steel strips for razor blades
103	IS 9442 : 1980	Hot rolled steel plates sheets and strips for manufacture of agricultural discs
104	IS 9476 : 1980	Specification for cold rolled steel strips for carbon steel razor blades
105	IS 9485 : 1980	Cold-reduced and hot-rolled carbon steel sheet for porcelain enamelling

<b>Sl No.</b>	<b>IS No.</b>	<b>Products</b>
106	IS 9516 : 1980	Heat resisting steels
107	IS 9523 : 2000	Ductile iron fittings for pressure pipes for water, gas and sewage
108	IS 9550 : 2001	Bright steel bars – Specification
109	IS 9962 : 1981	Specification for steel wire for needles
110	IS 10631 : 1983	Stainless steel for welding electrode core wire
111	IS 10632 (Part 2) : 1983	Specification for non magnetic stainless steel for electrical applications: Part 2 Specific requirements for binding wire
112	IS 10632 (Part 3) : 1983	Specification for non magnetic stainless steel for electrical applications: Part 3 Specific requirements for sheets, strips and plates
113	IS 10748 : 2004	Hot rolled steel strip for welded tubes and pipes
114	IS 10794 : 1984	Mild steel wire for cotter pins
115	IS 11169 (Part 1) : 1984	Steels for cold heading/cold extrusion application: Part 1 Wrought carbon and low alloy steels
116	IS 11169 (Part 2) : 1989	Steels for cold heading/cold extrusion applications — Specification: Part 2 Stainless steel
117	IS 11513 : 2017	Hot rolled carbon steel strip for cold rolling purposes — Specification
118	IS 11587 : 1986	Structural weather resistant steel
119	IS 11946 : 1987	Soft magnetic iron strips
120	IS 11947 : 1987	Soft magnetic iron rods, bars flats and sections
121	IS/ISO 11951 : 2016	Cold – reduced tin mill products — Blackplate
122	IS 11952 : 1986	Steels for piston pins (gudgeon pins)
123	IS 12045 : 1987	Alloys used in electrical resistance metallic heating elements
124	IS 12145 : 1987	Quenched and tempered alloy steel forgings for pressure vessels
125	IS 12146 : 1987	Specification for carbon manganese steel forgings for pressure vessels
126	IS 12262 : 1988	Trapezoidal steel wire for springs washers
127	IS 12591 : 2018	Cold-reduced electrolytic chromium/chromium oxide-coated steel
128	IS 12594 : 1988	Hot-dip zinc coating on structural steel bars for concrete reinforcement — Specification

<b>Sl No.</b>	<b>IS No.</b>	<b>Products</b>
129	IS 13352 : 1992	Stock for forgings produced from continuously cast blooms, billets and slabs
130	IS 13387 : 1992	Tool steel forgings for metal forming
131	IS 13620 : 1993	Fusion bonded epoxy coated reinforcing bars
132	IS 14246 : 2013	Continuously pre-painted galvanized steel sheets and coils
133	IS 14268 : 1995	Uncoated stress relieved low relaxation seven-ply strand for pre-stressed concrete
134	IS 14331 : 1995	Steels for high temperature bolting applications — Specification
135	IS 14650 : 1999	Carbon steel cast billet ingots, billets, blooms and slabs for rerolling purposes — Specification
136	IS 14652 : 1999	18 percent nickel maraging steel bars and rods
137	IS 14698 : 1999	Carbon and low alloy billets, blooms, slabs and bars for manufacture of shell bodies and proof shots used in defence services
138	IS 15103 : 2002	Fire resistant steel — Specification
139	IS 15391 : 2003	Oriented electrical steel sheet and strip — Semi-processed type — Specification
140	IS 15647 : 2006	Hot rolled steel narrow width strip for welded tubes and pipes
141	IS 15911 : 2010	Structural steel (ordinary quality)
142	IS 15914 : 2011	High tensile strength flat rolled steel plate (up to 6 mm), sheet and strip for the manufacture of welded gas cylinder
143	IS 15961 : 2012	Hot dip aluminium-zinc alloy metallic coated steel strip and sheet (plain)
144	IS 15962 : 2012	Structural steel for building for structures with improved seismic resistance
145	IS 15965 : 2012	Pre-painted aluminium-zinc alloy metallic coated steel strip and sheet (plain)
146	IS 15997 : 2012	Low nickel austenitic stainless steel sheet and strip for utensils and kitchen applications — Specification
147	IS 16585 : 2016	Magnetic materials — Specification for individual material — Fe based amorphous strip delivered in the semi-processed state
148	IS 16644 : 2018	Stress-relieved, low relaxation steel wire for pre-stressed concrete



<b>Sl No.</b>	<b>IS No.</b>	<b>Products</b>
149	IS 16732 : 2019	Galvanized structural steel – Specification
150	IS 17111 : 2019/ ISO 683-17:2014	Heat-treated steels alloy and free-cutting steels — Ball and roller bearing steels
151	IS 17404 : 2020	Electrogalvanized hot rolled and cold reduced carbon steel sheets and strips



## ANNEX G

### IMPORTANT POLICIES AND INITIATIVES OF GOVERNMENT OF INDIA

Steel is a de-regulated sector, Government acts as a facilitator, by creating conclusive policy environment for development of the steel sector. Government of India has notified National Steel Policy, 2017 which envisages development of a technologically advanced and globally competitive steel industry that provides environment for attaining self-sufficiency in steel production by providing policy support and guidance to steel producers. National Steel Policy covers all aspects of steel sector such as steel demand, steel capacity, raw material security, infrastructure and logistics, Research & Development (R&D) and energy efficiency.

#### I. PRODUCTION LINKED INCENTIVE (PLI) SCHEME

Production Linked Incentive (PLI) Scheme for Speciality Steel was approved by the Union Cabinet on 22.07.2021, with total financial outlay of Rs 6,322 crore to promote the manufacturing of 'Speciality Steel' within the country by attracting capital investment, generate employment and promote technology up-gradation in the steel sector.

#### II. STEEL QUALITY CONTROL ORDER (QCO)

Ministry of Steel has introduced Steel Quality Control Order (QCO) thereby banning sub-standard/ defective steel products both from domestic producers & imports to ensure the availability of quality steel to the industry, users and public at large. As per the Order, it is ensured that only quality steel conforming to the relevant BIS standards are made available to the end users. As on date 145 Indian Standards have been notified under the Quality Control Order covering carbon steel, alloy steel and stainless steel. Out of these, QCO on 144 Indian Standards have been enforced.

#### III. RESEARCH & DEVELOPMENT (R&D)

Ministry of Steel is providing financial assistance for pursuing Research & Development to address the technological challenges faced by the Iron & Steel sector.

Domestically Manufactured Iron & Steel Products (DMI&SP) Policy for promoting procurement of Made in India Steel by government and public sector projects.

Notification of Steel Scrap Recycling Policy to enhance the availability of domestically generated scrap.

[Source : <https://steel.gov.in/en/overview-steel-sector>]

## ANNEX H

### STANDARDIZATION ON THE SUBJECTS UNDER BIS AND OTHER INTERNATIONAL STANDARDS SETTING BODIES

International Standards generally reflect the best experience of industry, researchers, consumers and regulators worldwide, and effort may be made to adopt and use International Standards as national standards. However, full adoption may not be practicable in all cases for reasons such as national security, protection of human health or safety, or protection of the environment. It is therefore imperative to examine the standardization efforts on Steel and Steel structures, both nationally and internationally.

BIS represents India in the International Organization for Standardization (ISO). ISO is an independent, nongovernmental international standards setting organization, which through its established best practices of standardization formulates need based standards. Presently, it has a membership of over 170 countries, and has formulated over 25000 standards covering almost all aspects of technology, management and manufacturing.

ISO has several Technical Committees that work specifically on formulation of standards on Steel and Steel Structures.

An ISO member body can either participate in a Technical Committee (Technical Committee/Subcommittee) as a Participating member (P-member), and Observing Member (O-member), or may choose to be neither a P-member nor an O-member of a given committee.

A P-member has the obligation to participate actively in the work of the Committee, to vote on all questions formally submitted for voting within the committee, on new work item proposals, enquiry drafts and all drafts for final approval, and to contribute to meetings (P-members).

An O-member has the privilege to follow the work of the Committee as an observer, to receive committee documents and has the right to submit comments and to attend meetings.

A National Body may choose to be neither a P-member nor an O-member of a given committee, in which case it will have neither the rights nor the obligations indicated above with regard to the work of that committee. Nevertheless, all National Bodies, irrespective of their status within a committee, have the right to vote on enquiry drafts and on the final draft International

## ANNEX I

### RELEVANT TECHNICAL COMMITTEES UNDER ISO

Some of the ISO Technical Committees relevant to the subject of the handbook are as follows: **ISO/TC 17 Steel**

Standardization in the field of cast, wrought and cold-formed steel, including technical delivery conditions for steel tubes for pressure purposes, environment related to climate change and emerging technologies application in the iron and steel industry.

Excluded:

- steel tubes within the scope of ISO/TC 5;
- line pipe, casing, tubing and drill pipe within the scope of ISO/TC 67;
- methods of mechanical testing of metals within the scope of ISO/TC 164.

#### **ISO/TC 105 Steel Wire Ropes**

Standardization of steel wire ropes, wire rope terminations and wire rope slings.

#### **ISO/TC 167 Steel and Aluminium Structures**

Standardization in the field of structural use of steel and alloys of aluminium as applied in building, civil engineering and related structures.

The standards comprise the requirements for the design, fabrication and erection of steel and aluminium structures, together with materials, structural components and connections.

## ANNEX J

### MAPPING OF ACADEMIC CURRICULUM WITH INDIAN STANDARDS

<b>Course Title</b>	<b>Content</b>	<b>SP 7</b>	<b>IS 800</b>
Introduction to Structural Engineering	Introduction to various aspects associated with analysis and design of various structural systems, Buildings, Bridges and other infrastructure projects.	Part 6: Structural Design	Section 1: General (1.1 to 1.8)
	Properties of structural steel and structural steel sections	Section 6 (b) Materials Section 6 (c) General Design Requirements	Section 2: Materials (2.1 to 2.7)
Design of Steel Elements	Basic Concepts of Steel Design: Working Stress and Limit State Method	Section 6 (c) General Design Requirements Section 6 (e) Limit State Design Section 6 (m) Working Stress Design	Section 4: Methods of Structural Analysis Section 5: Limit State Design Section 11: Working Stress Design
	Introduction to Connections: Bolted (Ordinary and HSFG) and Welded connections	Section 6 (k): Connections (16.1 to 16.12.6)	Section 10: Connections (10.1 to 10.12)
	Tension members	Section 6 (f): Design of Tension Members (12.1 to 12.4.2)	Section 6: Design of Tension Members (6.1 to 6.4)
	Compression members, Builtup Columns, Beam Columns and Column Splices	Section 6 (g): Design of Compression Members (13.1 to 13.8.5)	Section 7: Design of Compression Members (7.1 to 7.8)
	Design of Beams: Laterally Supported, Unsupported and Builtup Beams	Section 6 (h): Design of Members Subjected to Bending	Section 8: Design of Members Subjected to Bending (8.6 to 8.10)

<b>Course Title</b>	<b>Content</b>	<b>SP 7</b>	<b>IS 800</b>
	Plate-girders including stiffeners, Splices	Section 6 (h): Design of Members Subjected to Bending	Section 7: (Design of Compression Members (7.1 to 7.8) Section 8: Design of Members Subjected to Bending (8.6 to 8.10)
	Column bases, Slab base, Gusseted base and Grillage footings	Section 6 (g): Design of Compression Members (13.1 to 13.8.5) Section 6 (m): Working Stress Design (17.1 to 17.6.3.2)	Section 7: Design of Compression Members (7.1 to 7.8)
	Beam to column connection, Introduction to semirigid connections	Section 6 (e): Fabrication and Erection (Annex E)	Section 10: Connections (10.1 to 10.12), Annex F
	Roof truss — Design of various components for different loadings	Section 6 (g): Design of Compression Members Section 6 (h): Design of Members Subjected to Bending Section 6 (j): Design subjected to Combined forces	Section 3: General Design Requirements Section 7: Design of Compression Members Section 8: Design of Members Subjected to Bending Section 10: Connections Section 13: Fatigue
	Plastic Analysis	Section 6 (d): Methods of Structural Analysis (10.5)	Section 4: Methods of Structural Analysis (4.5)
Design of steel structural systems	Design loads on buildings, wind and earthquake loads Loads: Calculation of wind, seismic and other loads, and their combinations acting on various structural systems.	Section 1: Loads Forces and Effects Section 6(a): General (1 to 4)	Section 3: General Design Requirements Section 8: Design of Members Subjected to Bending Section 12: Design and Detailing for Earthquake Load

Course Title	Content	SP 7	IS 800
	<p>Analysis: Introduction to elastic, plastic and stability analysis; Plastic design of continuous beams and simple frames.</p> <p>Structural Systems for Steel Multi-storey and Industrial Buildings: Braced and moment resisting frames; Industrial sheds; Gantry girders; Preengineered Building (PEB) Systems.</p>	<p>Section 6(d): Methods of Structural Analysis (10.1 to 10.6.2.2)</p> <p>Section 6 (a) Section 6 (n): Design and Detailing of Earthquake Loads (18.1 to 18.13.2)</p>	<p>IS 800 and IS 1893 (Part 1) Section 3: General Design Requirements (3.1 to 3.10)</p> <p>Section 4: Methods of Structural Analysis (4.1 to 4.6)</p> <p>Section 4: Methods of Structural Analysis (4.1 to 4.6)</p>