

Page 2 of 3

Anneaux-1

Thickness :- 12MM

Revision :-

Bevel:- NU

M24-7839

Date 05-08-2024

Expected Dispatch Date :-

Dimension Standard:- Inch

Customer Name : Absolute Glazing

Drawn By:- Tawheed Nazir

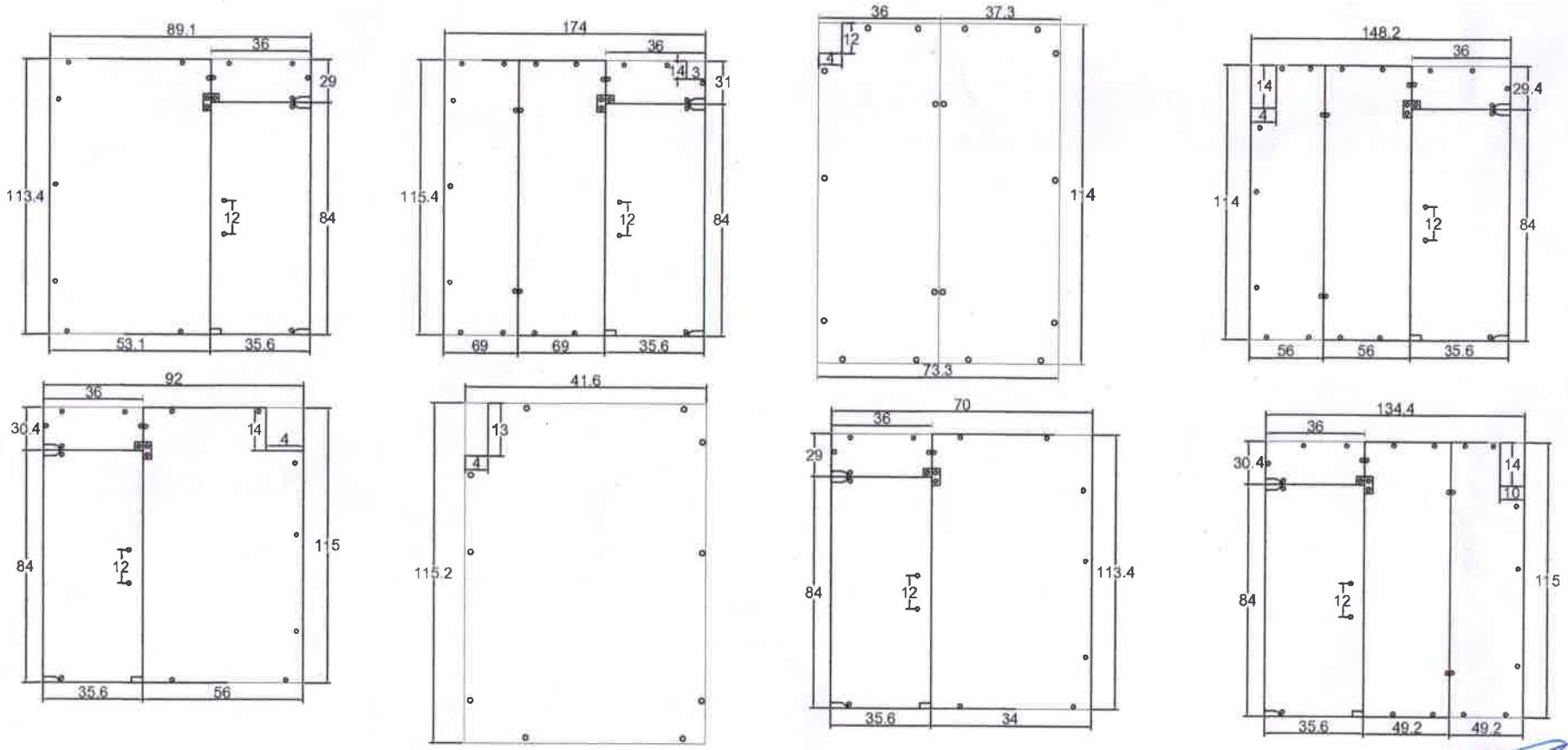

*

Raj Kumar
7/8/24

me

Kashmir Glass Industries
TIN 01742050938
I.E. Khrommah

Vehicle No :

Driver's Signature :

Dispatcher's Signature :

The driver has inspected and confirmed the glass was received in good condition during loading, By signing below, the driver releases kashmir glass industries from any responsibility for defects or damage afterward.

Page 3
of 3

Thickness :- 12MM

Revision :-

Bevel:- NO

M24-7839

Annealed - 1

Date 05-08-2024

Expected Dispatch Date :-

Dimension Standard:- Inch

Customer Name : Absolute Glazing

Drawn By:- Tawheed Nazir

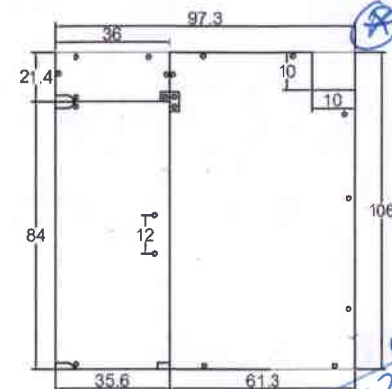
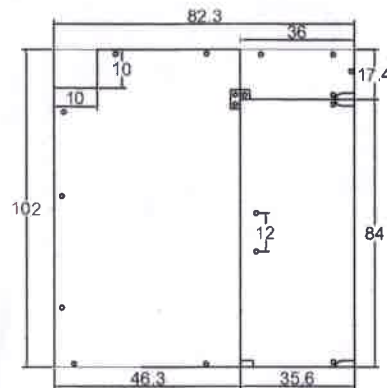
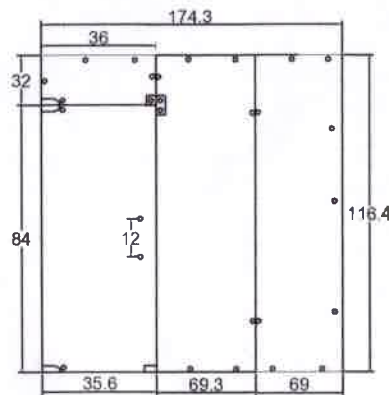
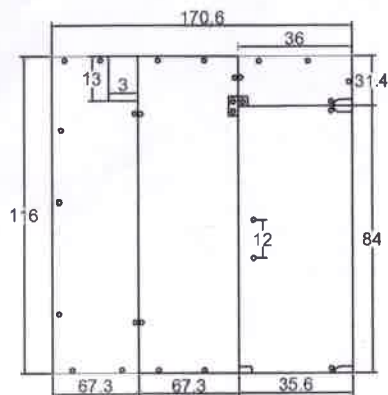
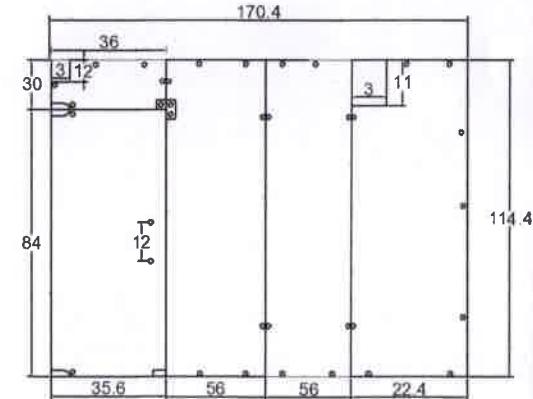
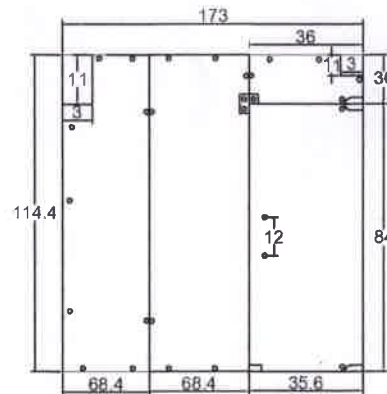
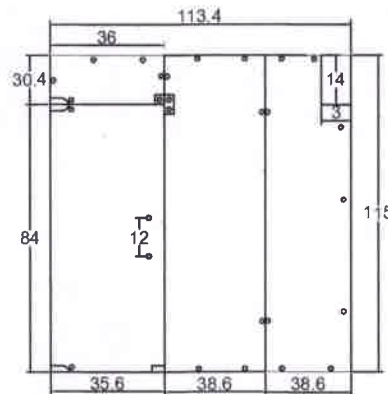
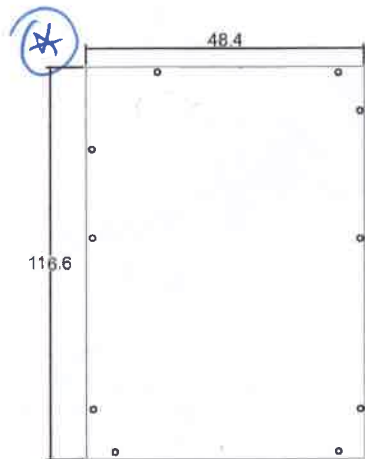

*

Vehicle No :

Rajkumar
7/8/24

Driver's Signature :

Dispatcher's Signature :



The driver has inspected and confirmed the glass was received in good condition during loading, By signing below, the driver releases kashmir glass industries from any responsibility for defects or damage afterward.

Page 1
of 3

Thickness :- 12MM

Revision :-

Bevel:- NU

M24-7839

Annexure - 1

Date 05-08-2024

Expected Dispatch Date :-

Dimension Standard:- Inch

Customer Name : Absolute Glazing

Drawn By:- Tawheed Nazir

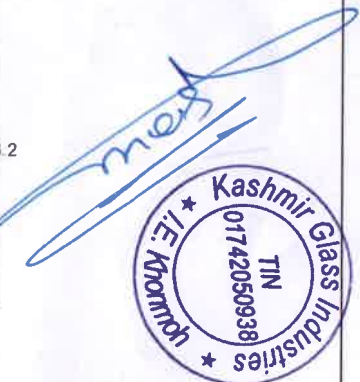
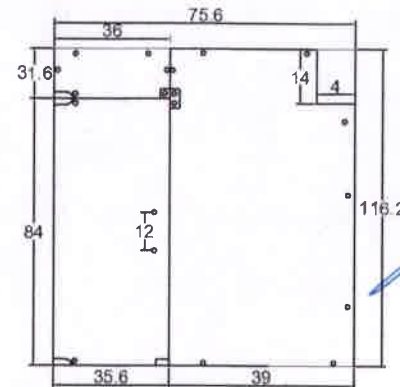
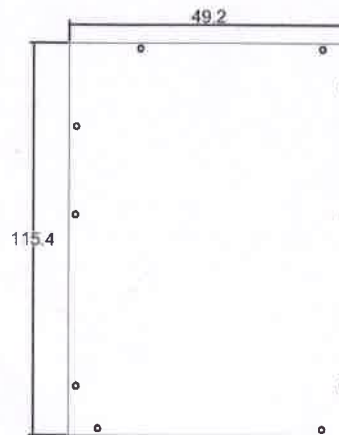
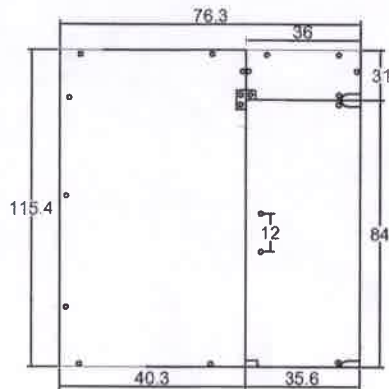
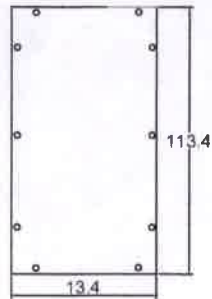
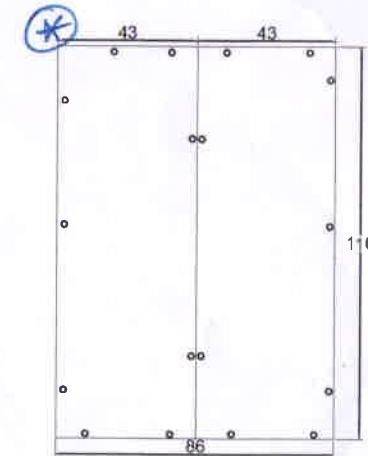
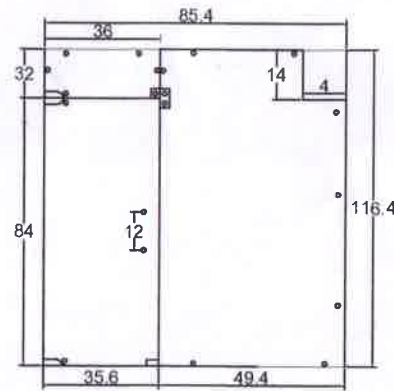
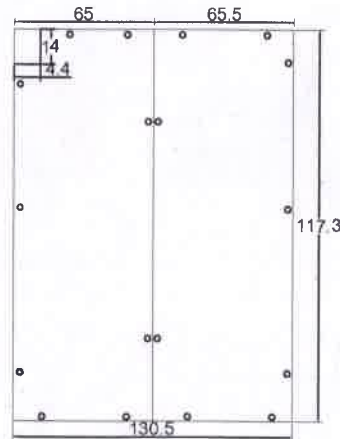
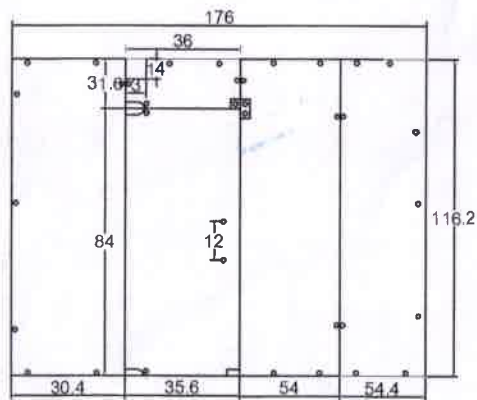

Raj Kumar
7/8/24

Vehicle No :

Driver's Signature :

Dispatcher's Signature :

The driver has inspected and confirmed the glass was received in good condition during loading, By signing below, the driver releases Kashmir glass industries from any responsibility for defects or damage afterward.

Ammer-VIII

Printed on 6-Aug-24 at 16:59

Tax Invoice

KASHMIR GLASS INDUSTRIES (From 2023) PLOT NO 290 Phase 3rd Industrial Estate Khonmoh Srinagar GSTIN/UID: 01AASF5158R1ZM State Name : Jammu & Kashmir, Code : 01 Contact : 01943501127 Ext 202, 203, +91-9596774155, 7889665060	Invoice No. KGI/24-25/365	e-Way Bill No. 381806943888	Dated 8-Jul-24
	Delivery Note		
Buyer (Bill to) M/S DEUCE (R) IGC LASSIPORA, PULWAMA GSTIN/UID : 01AAIFD7608K1ZI State Name : Jammu & Kashmir, Code : 01 Place of Supply : Jammu & Kashmir	Reference No. & Date.		Other References
	Dispatch Doc No.		Delivery Note Date
Dispatched through Road		Destination Anantnag	
Bill of Lading/LR-RR No. dt. 8-Jul-24		Motor Vehicle No. JK04D7842	

Sl No.	Description of Goods	HSN/SAC	GST Rate	Quantity	Rate	per	Amount	
1	KGI TOUGHENED GLASS 12MM	70071900	18 %	23.000 sqmtr	1,330.00	sqmtr	30,590.10	
2	KGI TOUGHENED GLASS 10MM	70071900	18 %	12.000 sqmtr	1,160.01	sqmtr	13,920.06	
							44,510.16	
CGST							9 %	4,005.92
SGST							9 %	4,005.92
Total				35.000 sqmtr			₹ 52,522.00	

Amount Chargeable (in words) E. & O.E

INR Fifty Two Thousand Five Hundred Twenty Two Only

HSN/SAC	Taxable Value	CGST		SGST/UTGST		Total Tax Amount
		Rate	Amount	Rate	Amount	
70071900	44,510.16	9%	4,005.92	9%	4,005.92	8,011.84
Total	44,510.16		4,005.92		4,005.92	8,011.84

Tax Amount (in words) : INR Eight Thousand Eleven and Eighty Four paise Only

Company's Bank Details

A/c Holder's Name : KASHMIR GLASS INDUSTRIES (From 2023)
Bank Name : J K Bank CC558
A/c No. : 0200020100000558
Branch & IFS Code : CHANPORA & JAKA0CHANPO
SWIFT Code :

Declaration

For Sale Within J&K Only

Customer's Seal and Signature

for KASHMIR GLASS INDUSTRIES (From 2023)

Prepared by

Verified by

Authorised Signatory

This is a Computer Generated Invoice

Tax Invoice

KASHMIR GLASS INDUSTRIES (From 2023) PLOT NO 290 Phase 3rd Industrial Estate Khonmoh Srinagar GSTIN/UID: 01AASF5158R1ZM State Name : Jammu & Kashmir, Code : 01 Contact : 01943501127 Ext 202, 203,+91-9596774155, 7889665060		Invoice No. KGI/24-25/372 e-Way Bill No. 321807906978 Dated 10-Jul-24
Buyer (Bill to) M/S DEUCE (R) IGC LASSIPORA, PULWAMA GSTIN/UID : 01AAIFD7608K1ZI State Name : Jammu & Kashmir, Code : 01 Place of Supply : Jammu & Kashmir		Delivery Note
		Reference No. & Date.
		Other References
		Dispatch Doc No.
		Delivery Note Date
		Dispatched through Road
		Destination IGC LASSIPORA, PULWAMA
		Bill of Lading/LR-RR No. dt. 10-Jul-24
		Motor Vehicle No. JK01AK4998

Sl No.	Description of Goods	HSN/SAC	GST Rate	Quantity	Rate	per	Amount
1	KGI TOUGHENED GLASS 6MM	70071900	18 %	123.000 sqmtr	620.00	sqmtr	76,260.00
	CGST					9 %	6,863.40
	SGST					9 %	6,863.40
	Total			123.000 sqmtr			₹ 89,986.80

Amount Chargeable (in words) E. & O.E
INR Eighty Nine Thousand Nine Hundred Eighty Six and Eighty paise Only

HSN/SAC	Taxable Value	CGST		SGST/UTGST		Total Tax Amount
		Rate	Amount	Rate	Amount	
70071900	76,260.00	9%	6,863.40	9%	6,863.40	13,726.80
Total	76,260.00		6,863.40		6,863.40	13,726.80

Tax Amount (in words) : **INR Thirteen Thousand Seven Hundred Twenty Six and Eighty paise Only**

Company's Bank Details
A/c Holder's Name : KASHMIR GLASS INDUSTRIES (From 2023)
Bank Name : J K Bank CC558
A/c No. : 0200020100000558
Branch & IFS Code : CHANPORA & JAKA0CHANPO
SWIFT Code :

Declaration
For Sale Within J&K Only

Customer's Seal and Signature	for KASHMIR GLASS INDUSTRIES (From 2023)
Prepared by	Verified by
	Authorised Signatory

This is a Computer Generated Invoice

Tax Invoice

KASHMIR GLASS INDUSTRIES (From 2023) PLOT NO 290 Phase 3rd Industrial Estate Khonmoh Srinagar GSTIN/UIN: 01AASF5158R1ZM State Name : Jammu & Kashmir, Code : 01 Contact : 01943501127 Ext 202, 203,+91-9596774155, 7889665060	Invoice No. e-Way Bill No. KGI/24-25/392 301811246541	Dated 16-Jul-24
	Delivery Note	
Buyer (Bill to) M/S DEUCE (R) IGC LASSIPORA, PULWAMA GSTIN/UIN : 01AAIFD7608K1ZI State Name : Jammu & Kashmir, Code : 01 Place of Supply : Jammu & Kashmir	Reference No. & Date.	Other References
	Dispatch Doc No.	Delivery Note Date
	Dispatched through Road	Destination Kulgam
	Bill of Lading/LR-RR No. dt. 16-Jul-24	Motor Vehicle No. JK04D7842

Sl No.	Description of Goods	HSN/SAC	GST Rate	Quantity	Rate	per	Amount
1	KGI TOUGHENED GLASS 12MM	70071900	18 %	34.000 sqmtr	1,330.00	sqmtr	45,220.00
	CGST					9 %	4,069.80
	SGST					9 %	4,069.80
	Total			34.000 sqmtr			₹ 53,359.60

Amount Chargeable (in words) E. & O.E

INR Fifty Three Thousand Three Hundred Fifty Nine and Sixty paise Only

HSN/SAC	Taxable Value	CGST		SGST/UTGST		Total Tax Amount
		Rate	Amount	Rate	Amount	
70071900	45,220.00	9%	4,069.80	9%	4,069.80	8,139.60
Total	45,220.00		4,069.80		4,069.80	8,139.60

Tax Amount (in words) : INR Eight Thousand One Hundred Thirty Nine and Sixty paise Only

Company's Bank Details

A/c Holder's Name : KASHMIR GLASS INDUSTRIES (From 2023)

Bank Name : J K Bank CC558

A/c No. : 0200020100000558

Branch & IFS Code : CHANPORA & JAKA0CHANPO

SWIFT Code :

Declaration

For Sale Within J&K Only

Customer's Seal and Signature

for KASHMIR GLASS INDUSTRIES (From 2023)

Prepared by

Verified by

Authorised Signatory

This is a Computer Generated Invoice

Tax Invoice

KASHMIR GLASS INDUSTRIES (From 2023) PLOT NO 290 Phase 3rd Industrial Estate Khonmoh Srinagar GSTIN/UIN: 01AASF5158R1ZM State Name : Jammu & Kashmir, Code : 01 Contact : 01943501127 Ext 202, 203,+91-9596774155, 7889665060		Invoice No. KGI/24-25/433	e-Way Bill No. 301816738027	Dated 25-Jul-24	
Buyer (Bill to) M/S DEUCE (R) IGC LASSIPORA, PULWAMA GSTIN/UIN : 01AAIFD7608K1ZI State Name : Jammu & Kashmir, Code : 01 Place of Supply : Jammu & Kashmir		Delivery Note		Reference No. & Date.	
		Dispatch Doc No.		Delivery Note Date	
		Dispatched through Road		Destination Anantnag	
		Bill of Lading/LR-RR No. dt. 25-Jul-24		Motor Vehicle No. JK04D7842	

SI No.	Description of Goods	HSN/SAC	GST Rate	Quantity	Rate	per	Amount
1	KGI TOUGHENED GLASS 12MM	70071900	18 %	37.000 sqmtr	1,330.00	sqmtr	49,210.00
	CGST					9 %	4,428.90
	SGST					9 %	4,428.90
	Total			37.000 sqmtr			₹ 58,067.80

Amount Chargeable (in words) E. & O.E
INR Fifty Eight Thousand Sixty Seven and Eighty paise Only

HSN/SAC	Taxable Value	CGST		SGST/UTGST		Total Tax Amount
		Rate	Amount	Rate	Amount	
70071900	49,210.00	9%	4,428.90	9%	4,428.90	8,857.80
Total	49,210.00		4,428.90		4,428.90	8,857.80

Tax Amount (in words) : **INR Eight Thousand Eight Hundred Fifty Seven and Eighty paise Only**

Company's Bank Details
A/c Holder's Name : KASHMIR GLASS INDUSTRIES (From 2023)
Bank Name : J K Bank CC558
A/c No. : 0200020100000558
Branch & IFS Code : CHANPORA & JAKA0CHANPO
SWIFT Code :

Declaration
For Sale Within J&K Only

Customer's Seal and Signature for KASHMIR GLASS INDUSTRIES (From 2023)

Prepared by Verified by Authorised Signatory

This is a Computer Generated Invoice

Tax Invoice

KASHMIR GLASS INDUSTRIES (From 2023) PLOT NO 290 Phase 3rd Industrial Estate Khonmoh Srinagar GSTIN/UIN: 01AASF5158R1ZM State Name : Jammu & Kashmir, Code : 01 Contact : 01943501127 Ext 202, 203,+91-9596774155, 7889665060	Invoice No. KGI/24-25/443	e-Way Bill No. 351818257343	Dated 27-Jul-24
	Delivery Note		
Buyer (Bill to) M/S DEUCE (R) IGC LASSIPORA, PULWAMA GSTIN/UIN : 01AAIFD7608K1ZI State Name : Jammu & Kashmir, Code : 01 Place of Supply : Jammu & Kashmir	Reference No. & Date.		Other References
	Dispatch Doc No.		Delivery Note Date
Dispatched through ROAD		Destination LASSIPORA PULWAMA	
Bill of Lading/LR-RR No. dt. 27-Jun-25		Motor Vehicle No. JK04D7842	

Sl No.	Description of Goods	HSN/SAC	GST Rate	Quantity	Rate	per	Amount
1	KGI TOUGHENED GLASS 5MM	70071900	18 %	82.000 sqmtr	590.00	sqmtr	48,380.00
	CGST					9 %	4,354.20
	SGST					9 %	4,354.20
Total				82.000 sqmtr			₹ 57,088.40

Amount Chargeable (in words)

E. & O.E

INR Fifty Seven Thousand Eighty Eight and Forty paise Only

HSN/SAC	Taxable Value	CGST		SGST/UTGST		Total Tax Amount
		Rate	Amount	Rate	Amount	
70071900	48,380.00	9%	4,354.20	9%	4,354.20	8,708.40
Total	48,380.00		4,354.20		4,354.20	8,708.40

Tax Amount (in words) : INR Eight Thousand Seven Hundred Eight and Forty paise Only

Company's Bank Details

A/c Holder's Name : KASHMIR GLASS INDUSTRIES (From 2023)

Bank Name : J K Bank CC558

A/c No. : 0200020100000558

Branch & IFS Code : CHANPORA & JAKA0CHANPO

SWIFT Code :

Declaration

For Sale Within J&K Only

Customer's Seal and Signature

for KASHMIR GLASS INDUSTRIES (From 2023)

Prepared by

Verified by

Authorised Signatory

This is a Computer Generated Invoice

Tax Invoice

KASHMIR GLASS INDUSTRIES (From 2023) PLOT NO 290 Phase 3rd Industrial Estate Khonmoh Srinagar GSTIN/UIN: 01AASF5158R1ZM State Name : Jammu & Kashmir, Code : 01 Contact : 01943501127 Ext 202, 203, +91-9596774155, 7889665060	Invoice No. KGI/24-25/458	Dated 30-Jul-24
	Delivery Note	
Buyer (Bill to) M/S DEUCE (R) IGC LASSIPORA, PULWAMA GSTIN/UIN : 01AAIFD7608K1ZI State Name : Jammu & Kashmir, Code : 01 Place of Supply : Jammu & Kashmir	Reference No. & Date.	Other References
	Dispatch Doc No.	Delivery Note Date
	Dispatched through Road	Destination Shopian
	Bill of Lading/LR-RR No. dt. 30-Jul-24	Motor Vehicle No. JK04D7842

Sl No.	Description of Goods	HSN/SAC	GST Rate	Quantity	Rate	per	Amount
1	KGI TOUGHENED GLASS 12MM	70071900	18 %	8.800 sqmtr	1,330.00	sqmtr	11,704.00
	CGST					9 %	1,053.36
	SGST					9 %	1,053.36
	Round Off						0.28
	Total			8.800 sqmtr			₹ 13,811.00

Amount Chargeable (in words)

E. & O.E

INR Thirteen Thousand Eight Hundred Eleven Only

HSN/SAC	Taxable Value	CGST		SGST/UTGST		Total Tax Amount
		Rate	Amount	Rate	Amount	
70071900	11,704.00	9%	1,053.36	9%	1,053.36	2,106.72
Total	11,704.00		1,053.36		1,053.36	2,106.72

Tax Amount (in words) : INR Two Thousand One Hundred Six and Seventy Two paise Only

Company's Bank Details

A/c Holder's Name : KASHMIR GLASS INDUSTRIES (From 2023)

Bank Name : J K Bank CC558

A/c No. : 0200020100000558

Branch & IFS Code : CHANPORA & JAKA0CHANPO

SWIFT Code :

Declaration

For Sale Within J&K Only

Customer's Seal and Signature

for KASHMIR GLASS INDUSTRIES (From 2023)

Prepared by

Verified by

Authorised Signatory

This is a Computer Generated Invoice

Tax Invoice

KASHMIR GLASS INDUSTRIES (From 2023)
 PLOT NO 290
 Phase 3rd Industrial Estate
 Khonmoh Srinagar
 GSTIN/UIN: 01AASF5158R1ZM
 State Name : Jammu & Kashmir, Code : 01
 Contact : 01943501127 Ext 202, 203, +91-9596774155, 7889665060

Invoice No. e-Way Bill No.
 KGI/24-25/463 311820045015

Dated
 31-Jul-24

Delivery Note

Reference No. & Date.

Other References

Dispatch Doc No.

Delivery Note Date

Dispatched through
 Road

Destination
 Anantnag

Bill of Lading/LR-RR No.
 dt. 31-Jul-24

Motor Vehicle No.
 JK04D7842

Buyer (Bill to)

M/S DEUCE (R)
 IGC LASSIPORA, PULWAMA
 GSTIN/UIN : 01AAIFD7608K1ZI
 State Name : Jammu & Kashmir, Code : 01
 Place of Supply : Jammu & Kashmir

Sl No.	Description of Goods	HSN/SAC	GST Rate	Quantity	Rate	per	Amount
1	KGI TOUGHENED GLASS 12MM	70071900	18 %	30.850 sqmtr	1,330.00	sqmtr	41,030.50
2	KGI TOUGHENED GLASS 8MM	70071900	18 %	16.000 sqmtr	955.00	sqmtr	15,280.00
							56,310.50
	CGST					9 %	5,067.95
	SGST					9 %	5,067.95
	Total			46.850 sqmtr			₹ 66,446.40

Amount Chargeable (in words)

E. & O.E

INR Sixty Six Thousand Four Hundred Forty Six and Forty paise Only

HSN/SAC	Taxable Value	CGST		SGST/UTGST		Total Tax Amount
		Rate	Amount	Rate	Amount	
70071900	56,310.50	9%	5,067.95	9%	5,067.95	10,135.90
Total	56,310.50		5,067.95		5,067.95	10,135.90

Tax Amount (in words) : INR Ten Thousand One Hundred Thirty Five and Ninety paise Only

Company's Bank Details

A/c Holder's Name : KASHMIR GLASS INDUSTRIES (From 2023)

Bank Name : J K Bank CC558

A/c No. : 0200020100000558

Branch & IFS Code : CHANPORA & JAKA0CHANPO

SWIFT Code :

Declaration

For Sale Within J&K Only

Customer's Seal and Signature

for KASHMIR GLASS INDUSTRIES (From 2023)

Prepared by

Verified by

Authorised Signatory

This is a Computer Generated Invoice

Tax Invoice

KASHMIR GLASS INDUSTRIES (From 2023)

PLOT NO 290

Phase 3rd Industrial Estate

Khonmoh Srinagar

GSTIN/UIN: 01AASF5158R1ZM

State Name : Jammu & Kashmir, Code : 01

Contact : 01943501127 Ext 202, 203, +91-9596774155, 7889665060

Buyer (Bill to)

M/S DEUCE (R)

IGC LASSIPORA, PULWAMA

GSTIN/UIN : 01AAIFD7608K1Z1

State Name : Jammu & Kashmir, Code : 01

Place of Supply : Jammu & Kashmir

Invoice No. KGV24-25/463	e-Way Bill No. 311820045015	Dated 31-Jul-24
Delivery Note		
Reference No. & Date.		Other References
Dispatch Doc No.		Delivery Note Date
Dispatched through Road		Destination Anantnag
Bill of Lading/LR-RR No. dt. 31-Jul-24		Motor Vehicle No. JK04D7842

Sl No.	Description of Goods	HSN/SAC	GST Rate	Quantity	Rate	per	Amount
1	KGI TOUGHENED GLASS 12MM	70071900	18 %	30.850 sqmtr	1,330.00	sqmtr	41,030.50
2	KGI TOUGHENED GLASS 8MM	70071900	18 %	16.000 sqmtr	955.00	sqmtr	15,280.00
							56,310.50
	CGST					9 %	5,067.95
	SGST					9 %	5,067.95

Toll Free: 1800-2030-320

PI No: M24-7778

Mate: Toughen CI 12mm

Size: 104.2 X 78

Glass No: Glass-1.1

Customer: Afzal Sahib



www.kashmirglassindustries.com

Toll Free: 1800-2030-320

PI No: M24-7778

Mate: Toughen CI 12mm

Size: 104.2 X 90

Glass No: Glass-2.1

Customer: Afzal Sahib



www.kashmirglassindustries.com

Toll Free: 1800-2030-320

PI No: M24-7778

Mate: Toughen CI 12mm

Size: 104.2 X 90.4

Glass No: Glass-3.1

Customer: Afzal Sahib



www.kashmirglassindustries.com

Toll Free: 1800-2030-320

PI No: M24-7778

Mate: Toughen CI 12mm

Size: 84 X 35.6

Glass No: Glass-4.1

Customer: Afzal Sahib



www.kashmirglassindustries.com

Toll Free: 1800-2030-320

PI No: M24-7778

Mate: Toughen CI 12mm

Size: 19.6 X 36

Glass No: Glass-5.1

Customer: Afzal Sahib



www.kashmirglassindustries.com

Toll Free: 1800-2030-320

PI No: M24-7778

Mate: Toughen CI 12mm

Size: 96 X 137

Glass No: Glass-6.1



TAX INVOICE
INVOICE ISSUED UNDER SECTION -31 OF CGST

DUPLICATE FOR TRANSPORTER

Invoice To:
KASHMIR GLASS INDUSTRIES, SRINAGAR
290, PHASE 3RD, INDUSTRIAL ESTATE KHONMOH PIN NO. - 191104 MOB.
NO. - 9596785001
SRINAGAR 191104 JAMMU AND KASHMIR, INDIA -

STATE : JAMMU AND KASHMIR(01)
Registration No : 01AASF5158R1ZM

Dispatch To: KASHMIR GLASS INDUSTRIES, SRINAGAR 290, PHASE 3RD,
INDUSTRIAL ESTATE KHONMOH PIN NO. - 191104 MOB. NO. -
9596785001 SRINAGAR 191104, INDIA -

Registration No : 01AASF5158R1ZM

Place of Supply
State Name/Code
JAMMU AND KASHMIR(01)



Gold Plus Glass Industry Limited
Village:Thithola,Roorkee-Laksar road
Tehsil:Roorkee Distt:Haridwar
UTTARAKHAND-247667,INDIA
Ph: 01332-305000
FAX: 01332-305050
GSTIN No: 05AACCG5196J1ZE
PAN NO: AACCG5196J
STATE CODE: 05

INVOICE CURRENCY	: INR
EXCHANGE RATE	:
INVOICE NO	: 24251105803
GATE ID	: 50480
DATED	: 20-JUL-24
ORDER.NO & DATE	: 2197825/20-JUL-24
TRANSPORTER	: KHUSHI RAM LOGISTICS
WAYBILL	:
TRUCK NO	: HR 67B 6938
LR NO	: 38338
DATE OF REMOVAL	: 20-JUL-24
TIME OF REMOVAL	: 15:11:49
DRIVER NO.	: 7078038290
PAYMENT TERM	: 35 Day Disc.

Description Of Goods/Services	HSN/SAC CODE	TOTAL CASES	TOTAL SHEETS	TOTAL QTY(SQM)	PRICE INR/SQM	ASSESSABLE VALUE	PACKING PREMIUM	DISCOUNT	TOTAL AMT
FG 5mm Clear Glass 1220mm x 2440mm size F with loose packing A4 LOTS: 05621342(42),05621291(42),05621338(42),05621289(42)	70051090	4	168	500.1	325	162533.28	0.00	22064.92	140468.31
FG 8mm Clear Glass 1830mm x 2440mm size F with loose packing A4 LOTS: 05613206(26),05613338(26),05613214(26),05613337(26),05613217(26),05613339(26),05613340(26),05613222(26)	70051090	8	208	928.76	552	512676.32	0.00	65564.40	447111.9:

TOTALS	IRN: 776acd835131a65f6db2d573cf1280dba9f2d7c80a8831dde6a22a200f5ecb48	GROSS WEIGHT : 24.36MT	12	376	1428.86	877	675209.60	0.00	87629.32	587580.28
---------------	---	------------------------	----	-----	---------	-----	-----------	------	----------	-----------

Beneficiary Name : Gold Plus Glass Industry Limited
Bank Name : AXIS BANK
Account No : GPGI7217
IFSC Code : UTIB0CCH274

FREIGHT		87629.32
FREIGHT PREMIUM		0.00
OVER HEIGHT PREMIUM		0.00
GPI EXTRA PREMIUM		0.00
FUEL SURCHARGE @5.95		59087.08
ENERGY SURCHARGE @14.00		139028.44
INSURANCE & HANDLING CHARGES	2.55%	22269.79
ASSESSIBLE VALUE		895594.91
CASH DISCOUNT 3%		0.00
OTHERS		0.00
NET ASSESSABLE VALUE		895594.91
SGST/UTGST	0%	0.00
CGST	0%	0.00
IGST	18%	161207.09
TCS	.1	1056.81
TOTAL		1057858.81

E-WAY BILL NUMBER : 311814055330
E-WAY BILL VALID TILL DATE : 24-JUL-24

TOTAL AMOUNT IN WORDS (INR) : Ten Lakh Fifty-Seven Thousand Eight Hundred Fifty-Eight And Eighty-One Paise Only

[Handwritten Signature]
20/7/2024



TAX INVOICE
INVOICE ISSUED UNDER SECTION -31 OF CGST

TRIPPLICATE FOR ASSESS



INVOICE CURRENCY	: INR
EXCHANGE RATE	:
INVOICE NO	: 24251105803
GATE ID	: 50480
DATED	: 20-JUL-24
ORDER.NO & DATE	: 2197825/20-JUL-24
TRANSPORTER	: KHUSHI RAM LOGISTICS
WAYBILL	:
TRUCK NO	: HR 67B 6938
LR NO	: 38338
DATE OF REMOVAL	: 20-JUL-24
TIME OF REMOVAL	: 15:11:49
DRIVER NO.	: 7078038290
PAYMENT TERM	: 35 Day Disc.

Invoice To:
KASHMIR GLASS INDUSTRIES, SRINAGAR
290, PHASE 3RD, INDUSTRIAL ESTATE KHONMOH PIN NO. - 191104 MOB.
NO. - 9596785001
SRINAGAR 191104 JAMMU AND KASHMIR ,INDIA -
STATE JAMMU AND KASHMIR(01)
Registration No :01AASF5158R1ZM

Dispatch To: KASHMIR GLASS INDUSTRIES, SRINAGAR 290, PHASE 3RD,
INDUSTRIAL ESTATE KHONMOH PIN NO. - 191104 MOB. NO. -
9596785001 SRINAGAR 191104, INDIA -

Registration No 01AASF5158R1ZM
Place of Supply
State Name/Code
JAMMU AND KASHMIR(01)

Gold Plus Glass Industry Limited
Village:Thithola,Roorkee-Laksar road
Tehsil:Roorkee Distt:Haridwar
UTTARAKHAND-247667,INDIA
Ph: 01332-305000
FAX: 01332-305050
GSTIN No: 05AACCG5196J1ZE
PAN NO: AACCG5196J
STATE CODE: 05

TERMS & CONDITIONS
1 In case of breakage claims if any, shall be forwarded along with photographs of the broken material taken on the truck before unloading.
2 Interest will be charged @ 24% if not paid as per agreement terms.
3 Goods once sold will not be taken back.
4 Subject to - Roorkee / DELHI jurisdiction only.
5 E&O.E
6 Whether tax is payable under reverse charge : NO

THK	MMSQM	THK	MMSQM
2 - 2.5 C	0.00	8 - 12 F	0.00
3 - 6 C	2500.51	3 - 6 E	0.00
8 - 12 C	7430.09	8 - 12 E	0.00
2 - 2.5 M	0.00	3 - 6 L	0.00
3 - 6 M	0.00	8 - 12 L	0.00
8 - 12 M	0.00	3 - 6 R	0.00
3 - 6 F	0.00	8 - 12 R	0.00
3 - 6 S	0.00	8 - 12 S	0.00
2 - 2.5 T	0.00	2 - 2.5 G	0.00
3 - 6 T	0.00	3 - 6 G	0.00
8 - 12 T	0.00	8 - 12 G	0.00

Certified that the particulars given above are true & correct and the amount represents the price actually charged and that there is no additional consideration directly or indirectly from the buyer.
For Gold Plus Glass Industry Limited

BILL OFFICER : GAURAV
S. INCHARGE : SUSHIL
QC INCHARGE : PARVEEN
CRANE OPER : SUMIT
AUTHORISED SIGNATORY

REGISTERED OFFICE : 4th Floor , Kings Mall , Rohini , Delhi 110085,
Tel: 011-66376000, Fax: 011-66376060.
E mail ID: Info@goldplusgroup.com & Website: www.goldplusgroup.com
CIN No: U26109DL2005PLC143705

Handwritten signature and date: 7/8/2024

