

BUREAU OF INDIAN STANDARD
DRAFT FOR COMMENTS ONLY

(Not to be reproduced without the permission of BIS or used as an Indian Standard)

भारतीय मानक मसौदा

**द्रवचालित गेट के लिये विभिन्न प्रकार की रबड की सीलों
के डिजाइन एवं उपयोग — दिशानिर्देश**

(IS 11855 का दूसरा पुनरीक्षण)

Draft Indian Standard

**DESIGN AND USE OF RUBBER SEALS FOR HYDRAULIC
GATES — RECOMMENDATIONS**

(Second Revision of IS 11855)

**Hydraulic Gates and Valves Sectional Committee, WRD
12**

**Last Date for Comments:
21/08/2024**

FOREWORD

(Formal Clause of the foreword will be added later)

This Indian Standard (Second Revision) was adopted by the Bureau of Indian Standards, after the draft finalized by the Hydraulic Gates and Valves Sectional Committee had been approved by the Water Resources Division Council.

This standard was first published in 1986 and was revised in 2004. In the second revision, IS 11855 : 2004 'Guidelines for design and use of different types of rubber seals for hydraulic gates' and IS 15466 : 2004 'Rubber seals for hydraulic gates — Specification' have been amalgamated and additional sketches for assembly details with wedge type of seal have been added for clarity of users. Hence IS 15466 : 2004 'Rubber seals for hydraulic gates — Specification' shall stand withdrawn.

There is no ISO standard on the subject. This standard has been formulated based on indigenous manufacturer's data/practices prevalent in the field in India.

Dams/Barrages are built for storage/diversion of water for irrigation or generation of electric power. In concrete dams, tunnels/spillways, head regulator of hydel channels, forebay intake structure, by-pass channels and draft tube of power house, the flow of water is controlled with the help of hydraulic gates.

To prevent flow of water that passes through closed gate, seals are provided either on the gate or on the metal frame in the gate slot. Rubber is the most commonly used material for seals, as it is elastic, deforms readily and regains its original shape on removal of load.

For the purpose of deciding whether a particular requirement of this standard is complied with, the final value, observed or calculated, expressing the result of a test or analysis, shall be rounded off in accordance with IS 2: 2022 'Rules for rounding off numerical values (*second revision*); The number of significant places retained in the rounded off value should be the same as that of the specified value in this standard.

Draft Indian Standard**DESIGN AND USE OF RUBBER SEALS FOR HYDRAULIC
GATES — RECOMMENDATIONS**

(Second Revision of IS 11855)

**Hydraulic Gates and Valves Sectional Committee, WRD
12****Last Date for Comments:
21/08/2024****1 SCOPE**

1.1 This standard lays down specification for rubber seals used for common types of hydraulic gates.

1.2 Guidelines for design and use of different types of rubber seals for common types of hydraulic gates are given in Annex A.

2 REFERENCES

The standards listed below contain provisions which through reference in this text constitute provisions of this standard. At the time of publication, the editions indicated were valid. All standards are subject to revision and parties to agreements based on these standards are encouraged to investigate the possibility of applying the most recent editions of the standards indicated below:

<i>IS No.</i>	<i>Title</i>
IS 3400	Methods of test for vulcanized rubber
(Part 1) : 2012/ISO 37 : 2011	Determination of tensile stress strain properties (<i>third revision</i>)
(Part 4) : 2012 ISO 188 : 2011	Accelerated ageing and heat resistance (<i>third revision</i>)
(Part 6) : 2012/ISO 1817 : 2011	Determination of the effect of liquids (<i>third revision</i>)
(Part 23) : 2002/ISO 7619 : 1997	Determination of indentation hardness by means of pocket hardness metres
IS 15466 : 2004	Rubber seals for hydraulic gates - Specification (Withdrawn)

3 MATERIALS

3.1 The basic polymer shall be natural rubber, or a co-polymer of butadiene and styrene, or a blend of both and the compound shall contain not less than 70 percent, by volume, of the basic polymer and the remainder shall consist of reinforcing carbon black, zinc oxide, accelerators, antioxidants, vulcanizing agents and plasticizers.

3.2 Rubber seals should be moulded to ensure homogeneous section. These may be clad by fluorocarbon.

3.3 On the hollow bulb seals, a core of rubber stock may be used in the bulb at the splice.

3.4 Caisson seals should be fully moulded.

4 PHYSICAL PROPERTIES

Physical properties of the compound shall conform to Table 1.

5 TYPES, SHAPES AND DIMENSIONS

5.1 The most common types of rubber seals used in gates are given in Table 2.

5.2 The tolerance on sectional dimension of all seals shall be ± 0.5 percent. However tolerance shall not apply to the thickness of cladding film. All the corner seals should be fully moulded.

Table 1 Physical Properties
(Clause 4)

SI No.	Property	Requirement	Methods of Test, Ref to	
			IS No.	Annex
(1)	(2)	(3)	(4)	(5)
i)	Shore A Durometer hardness	65 ± 5	IS 3400 (Part 23)	—
ii)	Elongation at break, percent, <i>Min</i>	450	IS 3400(Part 1)	—
iii)	Tensile strength, N/mm^2 , <i>Min</i>	14.5	IS: 3400(Part 1)	—
iv)	Mass of water absorbed in 7 days, percent, <i>Max</i>	10	IS 3400 (Part 6)	—
v)	Tensile strength after accelerated ageing test of 48 h in oxygen at 70 ± 1 °C and 2.1 ± 0.1 N/mm^2 pressure	Shall not be less than 80 percent of the strength before aging	IS 3400 (Part 4) and IS 3400 (Part 1)	
vi)	Low temperature brittleness	Non brittle after 3 min at -40 °C	—	B

Table 2 Types of Rubber Seals
(Clause 5.1)

SI No.	Types of Rubber Seals	Designation	Ref to Fig.
(1)	(2)	(3)	(4)
i)	Angle shaped seals	ASS	1
ii)	Flat/wedge seats	FWS	2
iii)	Music note seals	MNS	3
iv)	Double caisson seals	DCS	4
v)	Double bulb seals	DBS	5
vi)	Corner seals:		
	a) Type I	CST I	6
	b) Type II	CST II	7
	c) Type III	CST III	8
	d) Type IV	CST IV	9

NOTES

1 All corner seals should be fully moulded.

2 Figures 1 to 9 are only typical in nature. The assembly details with angel shaped seal are shown in Fig. 10

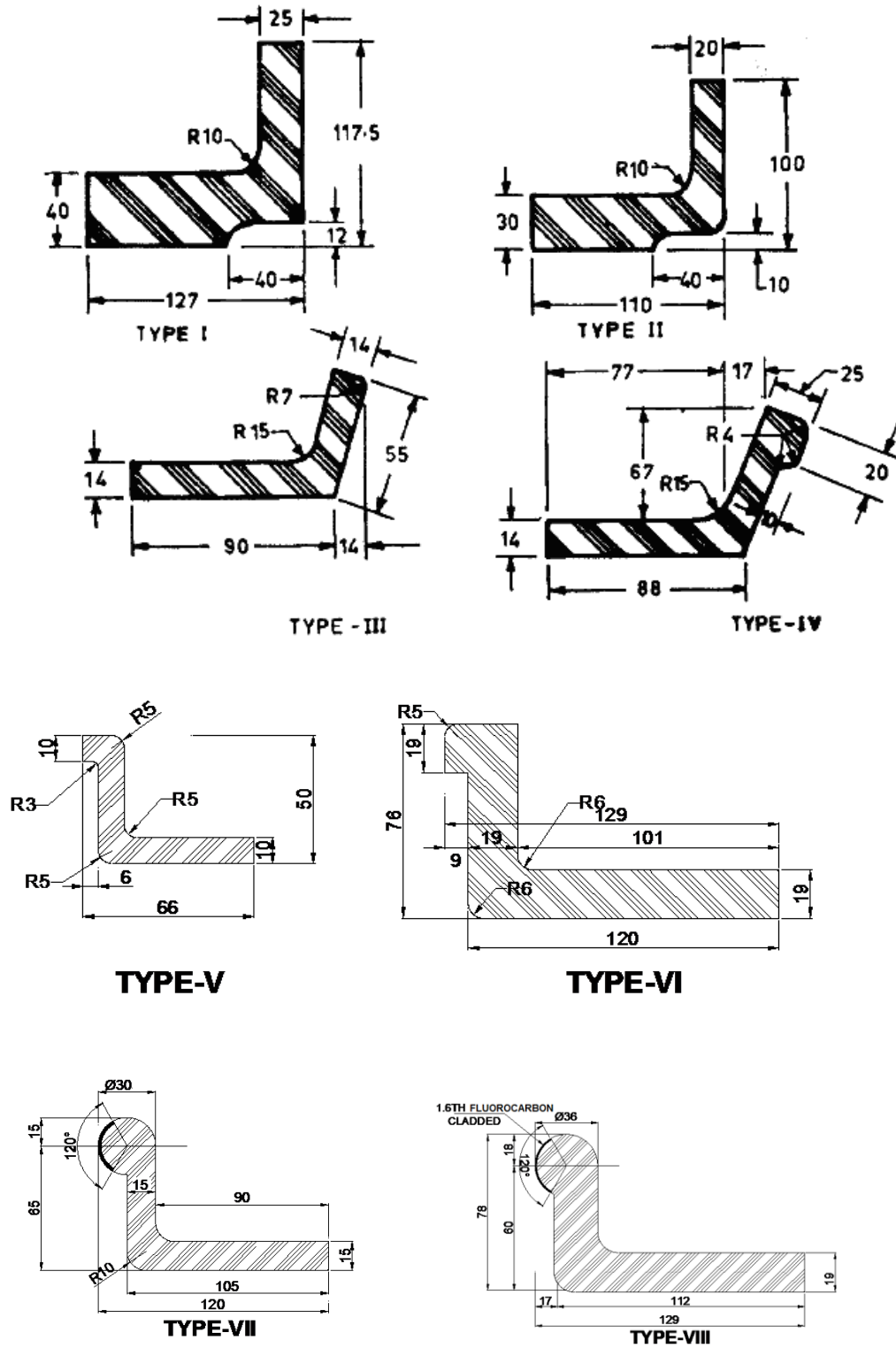

All dimensions in millimetres. (Not to Scale)

FIG. 1 COMMON SIZES OF ANGEL SHAPED SEALS

NOTE — The dimensions of the seals shown in the figure may be taken as indicative and nearest size seals as per moulds available with the manufacturers may also be used.

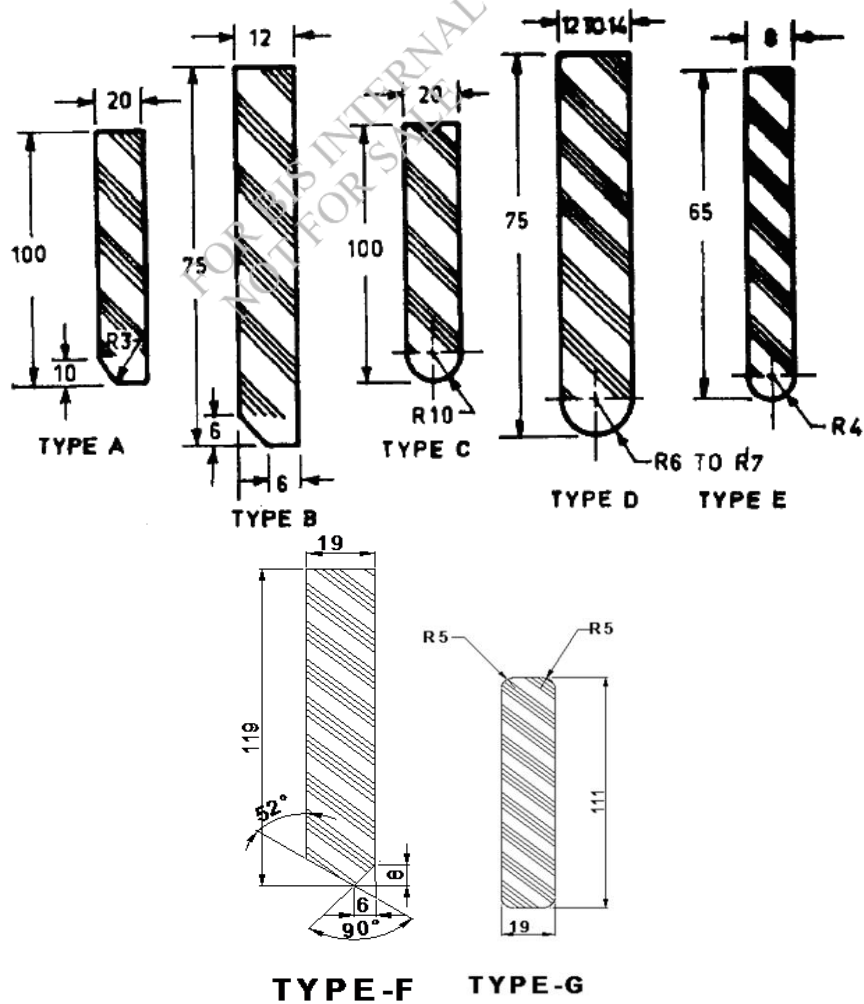

All dimensions in millimetres (Not to Scale)

FIG. 2 COMMON SIZES OF FLT SEALS

Note — The dimensions of the seals shown in the figure may be taken as indicative and nearest size seals as per moulds available

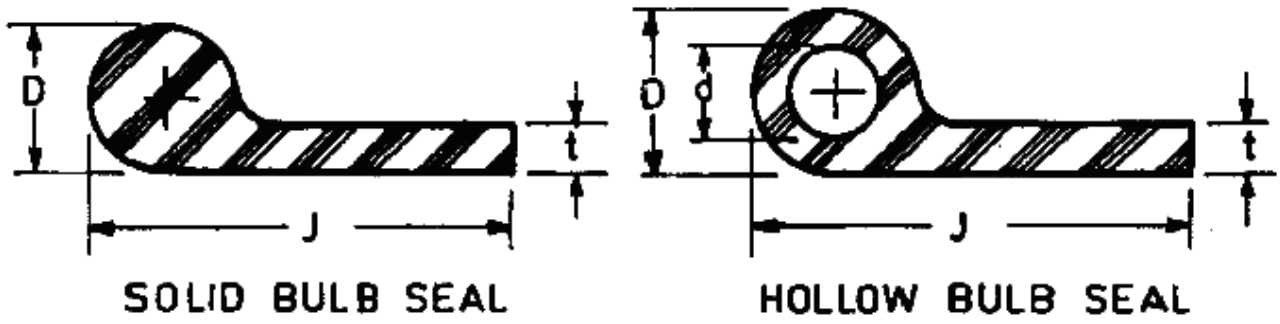

Dimensions

Sl. No.	Description	J	D	d	t
1	Solid & Hollow	57	22	10	8
2		100	44	15	14/18
3		125	44	15	14/18

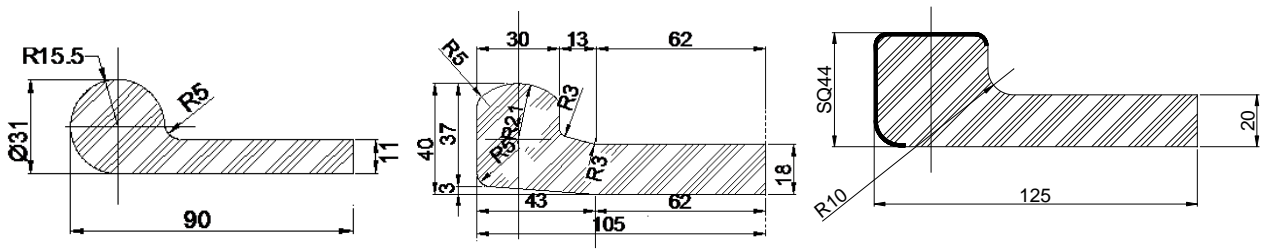

All dimensions in millimetres.

FIG. 3 COMMON SIZES OF MUSIC NOTE SEALS

NOTE — The dimensions of the seals shown in the figure may be taken as indicative and nearest size seals as per moulds available with the manufacturers may also be used.

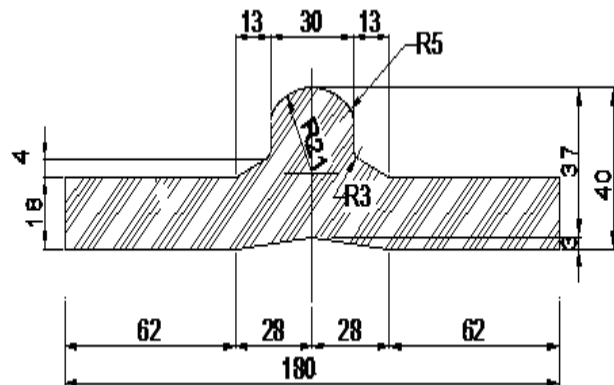
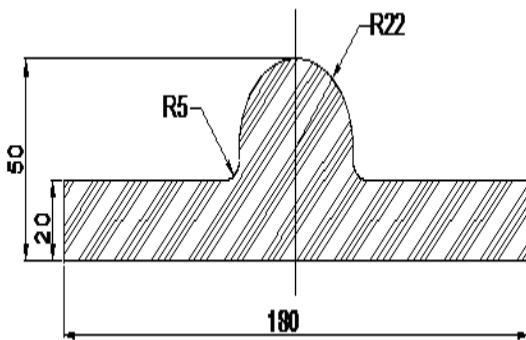
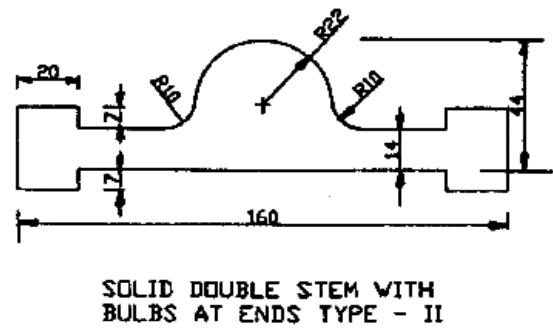
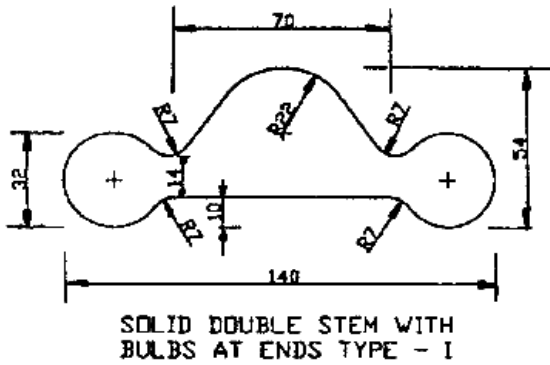
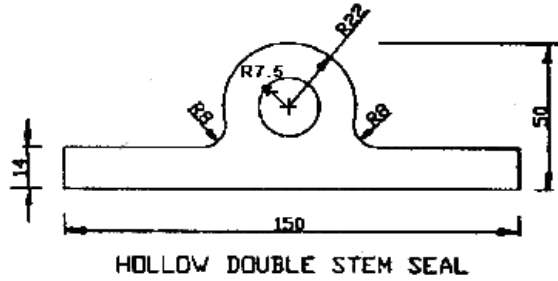
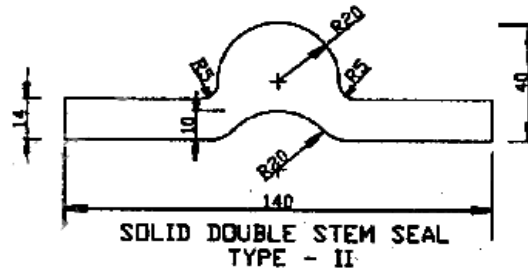
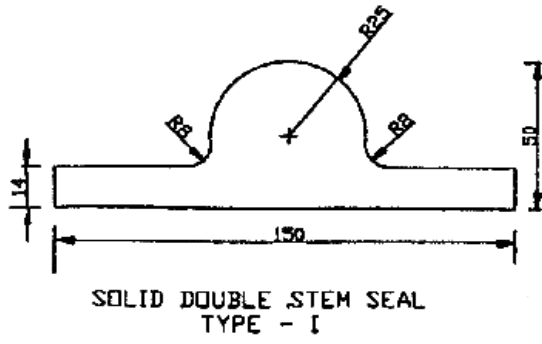

All dimensions in millimetres.

FIG. 4 COMMON SIZES OF DOUBLE STEM SEALS

NOTE — The dimensions of the seals shown in the figure may be taken as indicative and nearest size seals as per moulds available with the manufacturers may also be used (Thickness of stem shall not be less than 14mm).

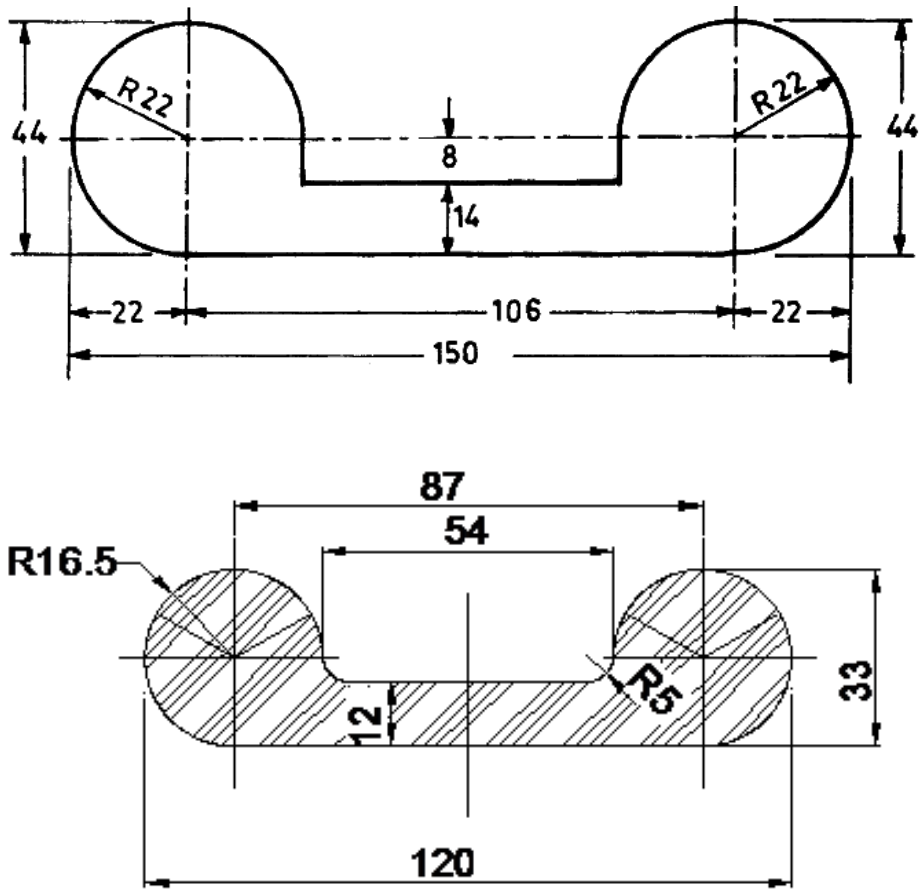

All dimensions in millimetres.

FIG. 5 COMMON SIZES OF DOUBLE BULB SEAL

NOTE — The dimensions of the seals shown in the figure may be taken as indicative and nearest size seals as per moulds available with the manufacturers may also be used. (Thickness of stem shall not be less than 14mm).

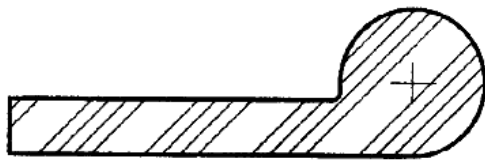
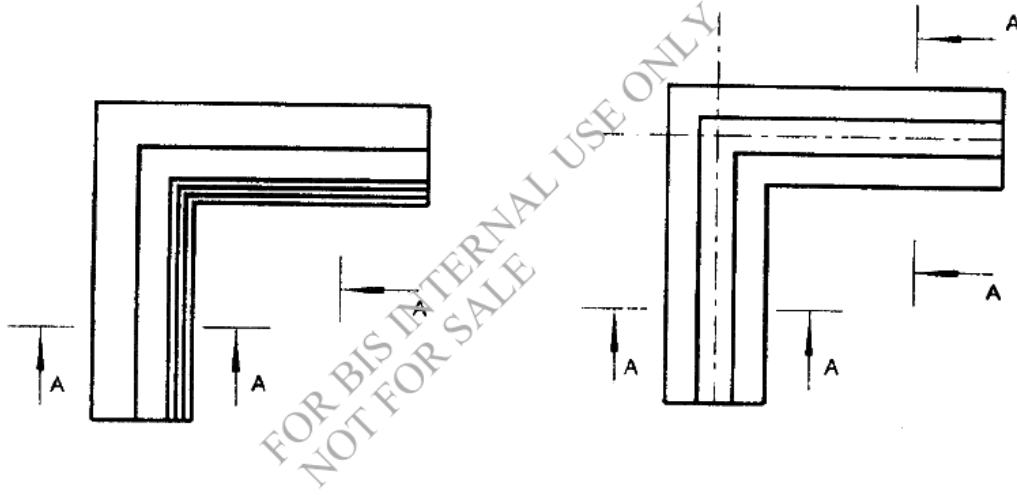

SECTION AA (ENLARGED VIEW)

FIG. 6 DETAIL OF MOULDED CORNER SEAL

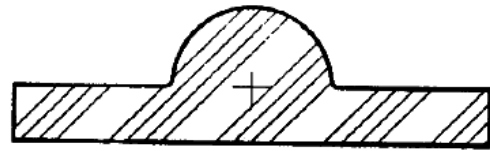

SECTION AA (ENLARGED VIEW)

FIG. 7 DETAIL OF MOULDED CORNER SEAL

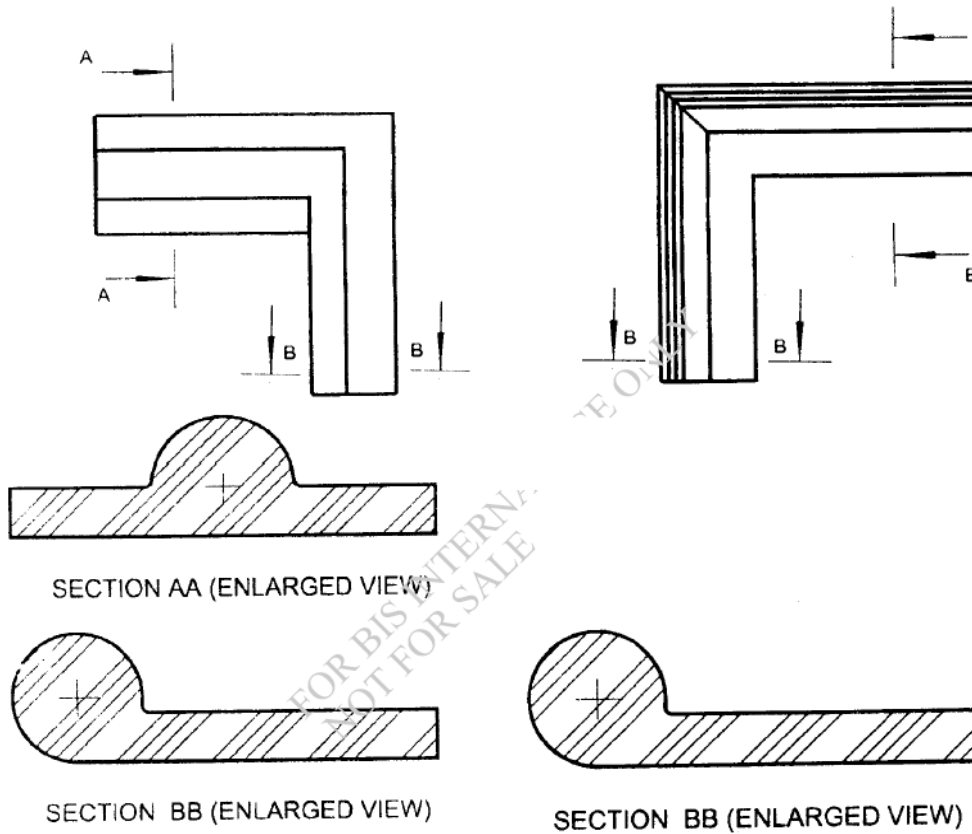

FIG. 8 DETAIL OF MOULDED CORNER SEAL

FIG. 9 DETAIL OF MOULDED CORNER SEAL

FIG 8 SECTION AA (ENLARGED VIEW)

FIG 8 SECTION BB (ENLARGED VIEW)

FIG. 8 DETAILS OF MOULDED CORNER SEAL

SECTION BB (ENLARGED VIEW)

FIG. 9 DETAILS OF MOULDED CORNER SEAL

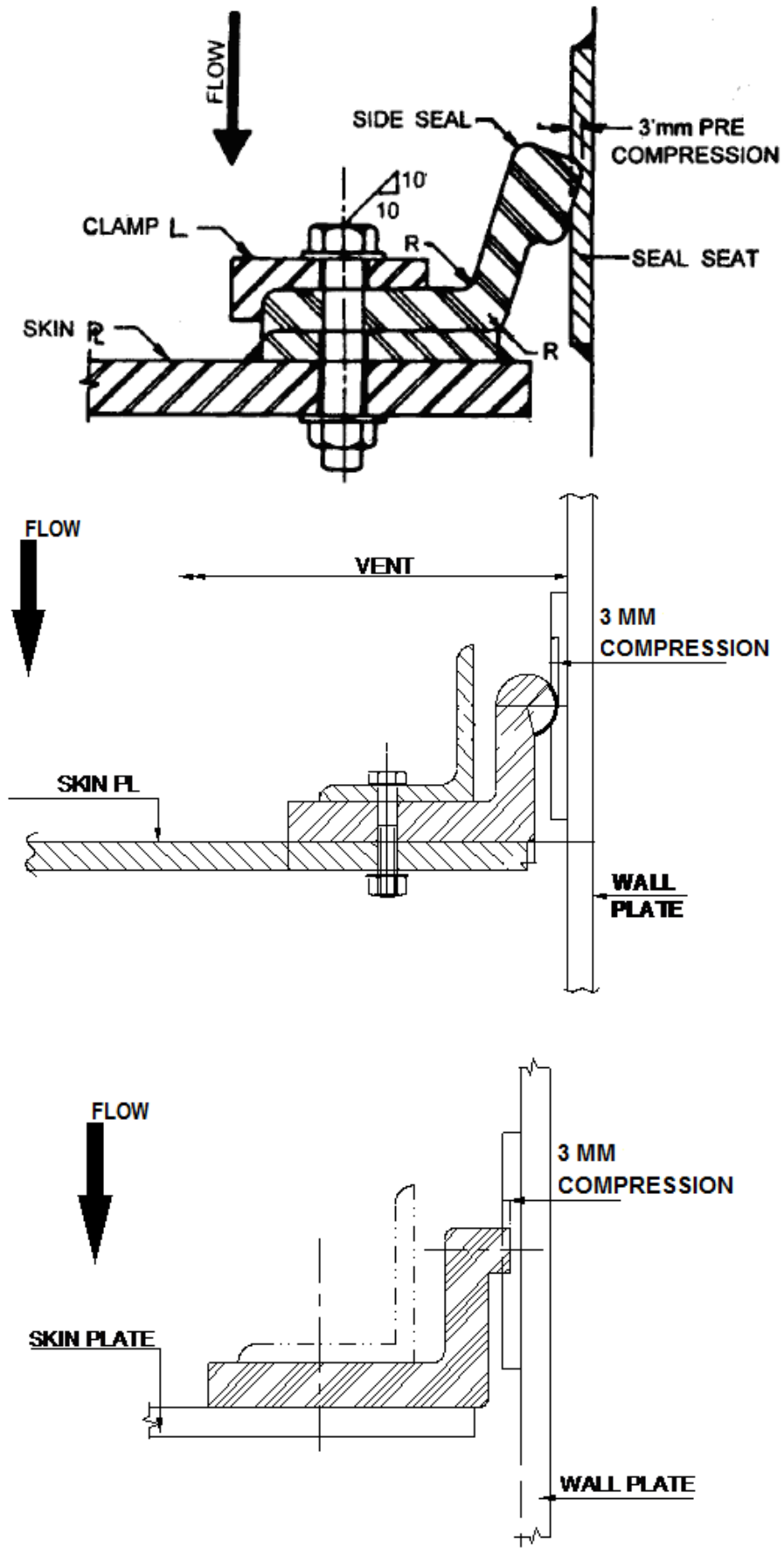

FIG. 10 ASSEMBLY DETAILS WITH ANGEL SHAPED SEAL

6 CLADDED SEALS

6.1 Rubber seals are fluorocarbon cladded to reduce frictional forces. The fluorocarbon is introduced into the mould along with the raw unvulcanized rubber compound and gets moulded or vulcanized simultaneously with the rubber so that the fluorocarbon film is inserted or recessed into the rubber. The thickness of cladding should not be less than 1.2 mm. Cladded seals may be used for unbalanced water head operation of gate for low, medium and high head or at discretion of designer.

NOTE — No fluorocarbon shall be cut during site joints. Therefore plain rubber is to be provided at site joints. A gap of 10 mm shall be provided in between fluorocarbon sheets and also no fluorocarbon at corners and at bottom where compression takes place for flexibility and not to fail the fluorocarbon. As far as possible fluorocarbon seals are to be transported as straight one and shall not be circled.

6.2 These seals are less flexible than rubber seals. The cladding may be provided on portion of the seal as shown in Fig. 11 to Fig. 16 to overcome the drawback of reduced flexibility of fully cladded seals. Minimum included angle of cladding should be 120°.

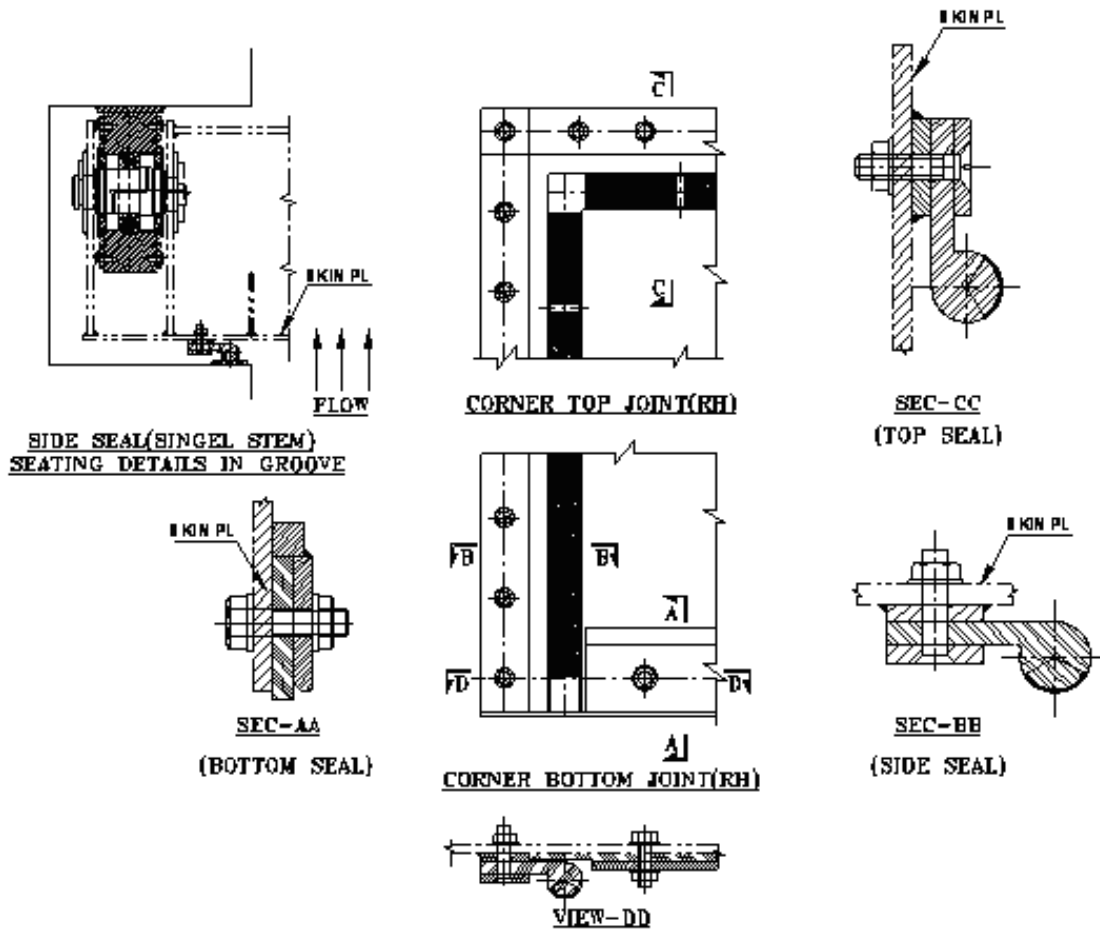

FIG 11 SIDE (SINGLE STEM), TOP AND BOTTOM SEAL JOINTS (UP STREAM)

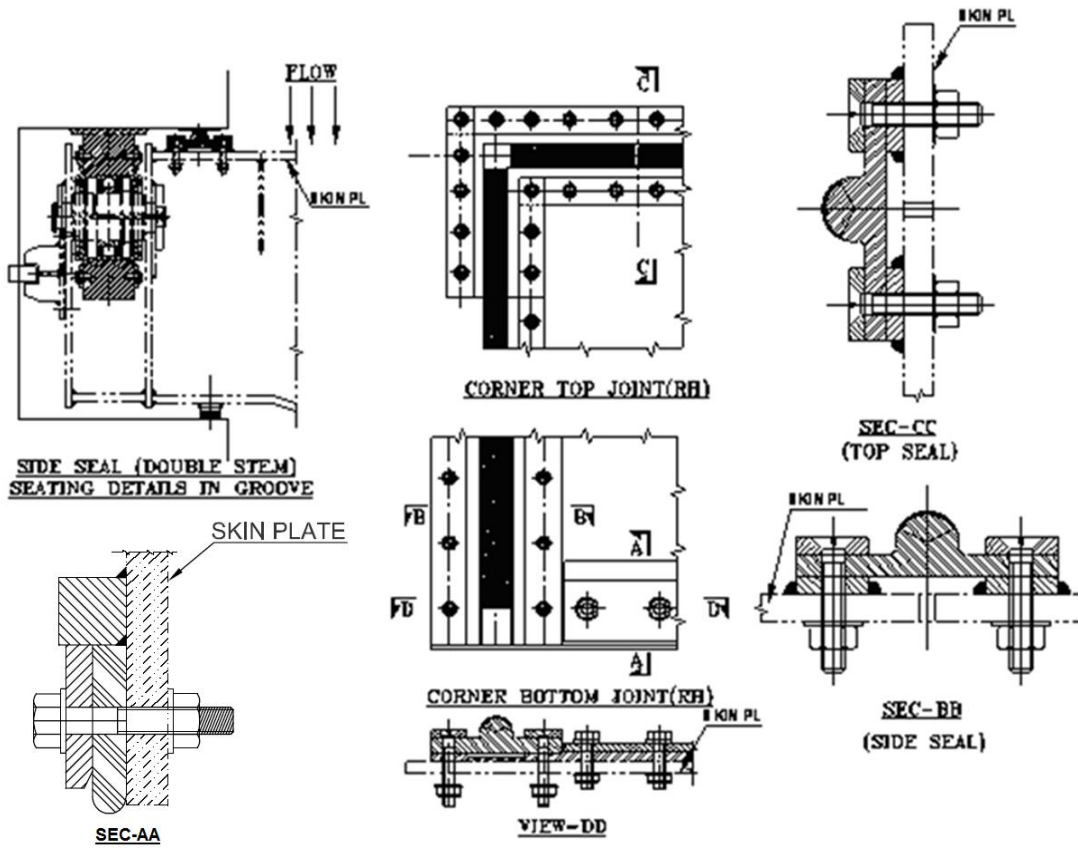

FIG 12 SIDE (DOUBLE STEM), TOP AND BOTTOM SEAL JOINTS (DOWNSTREAM)

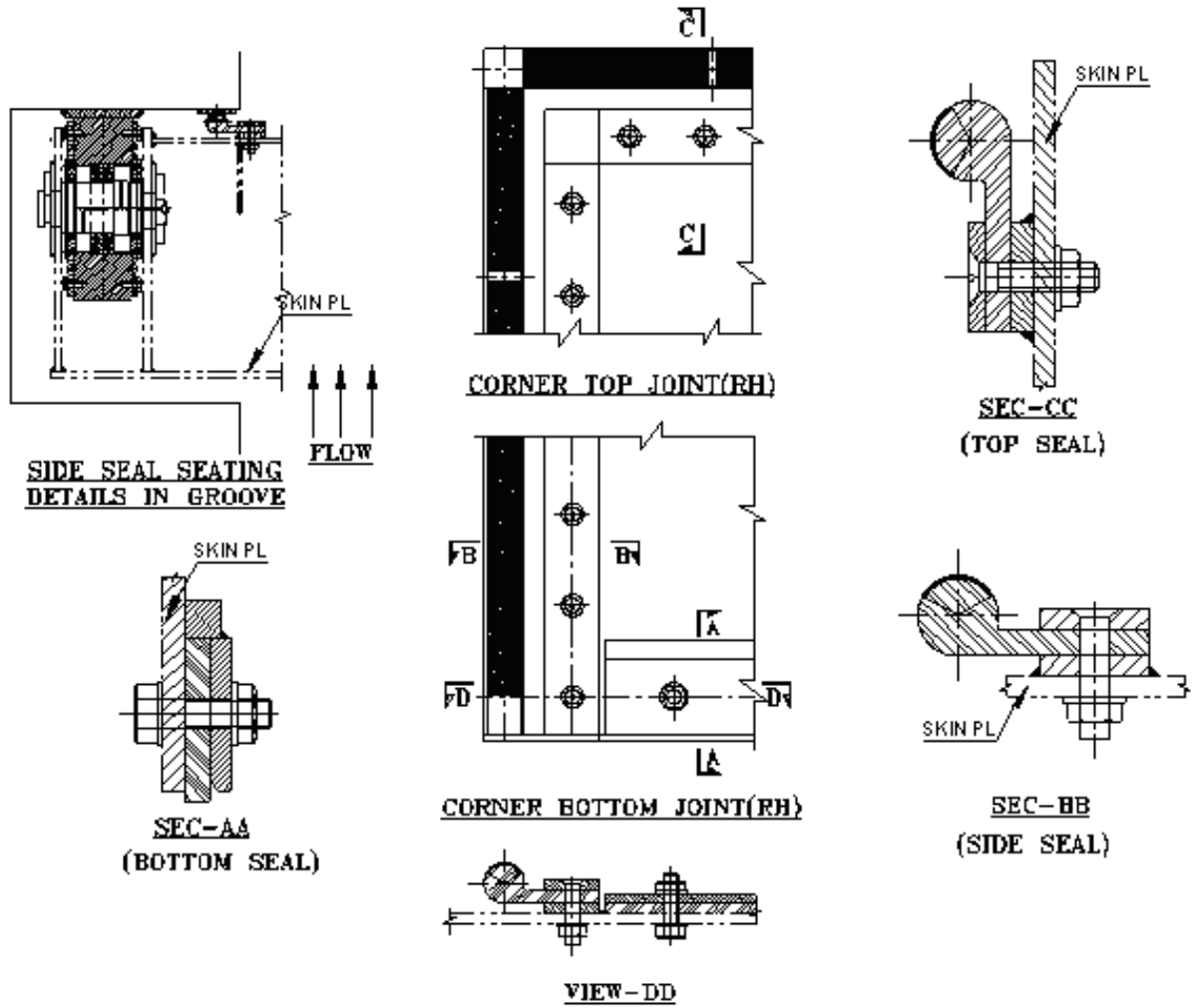

FIG 13 SIDE, TOP AND BOTTOM SEAL JOINTS (UP STREAM)

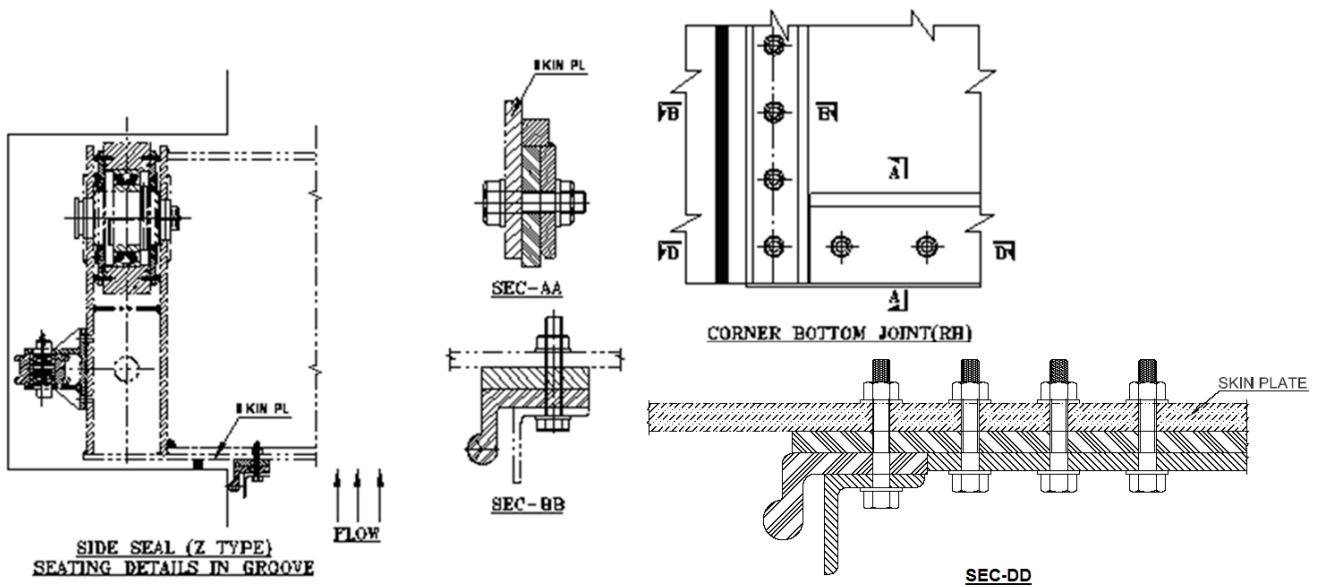

FIG 14 SIDE AND BOTTOM SEAL JOINTS (UP STREAM) FOR GATES NOT HAVING TOP SEAL

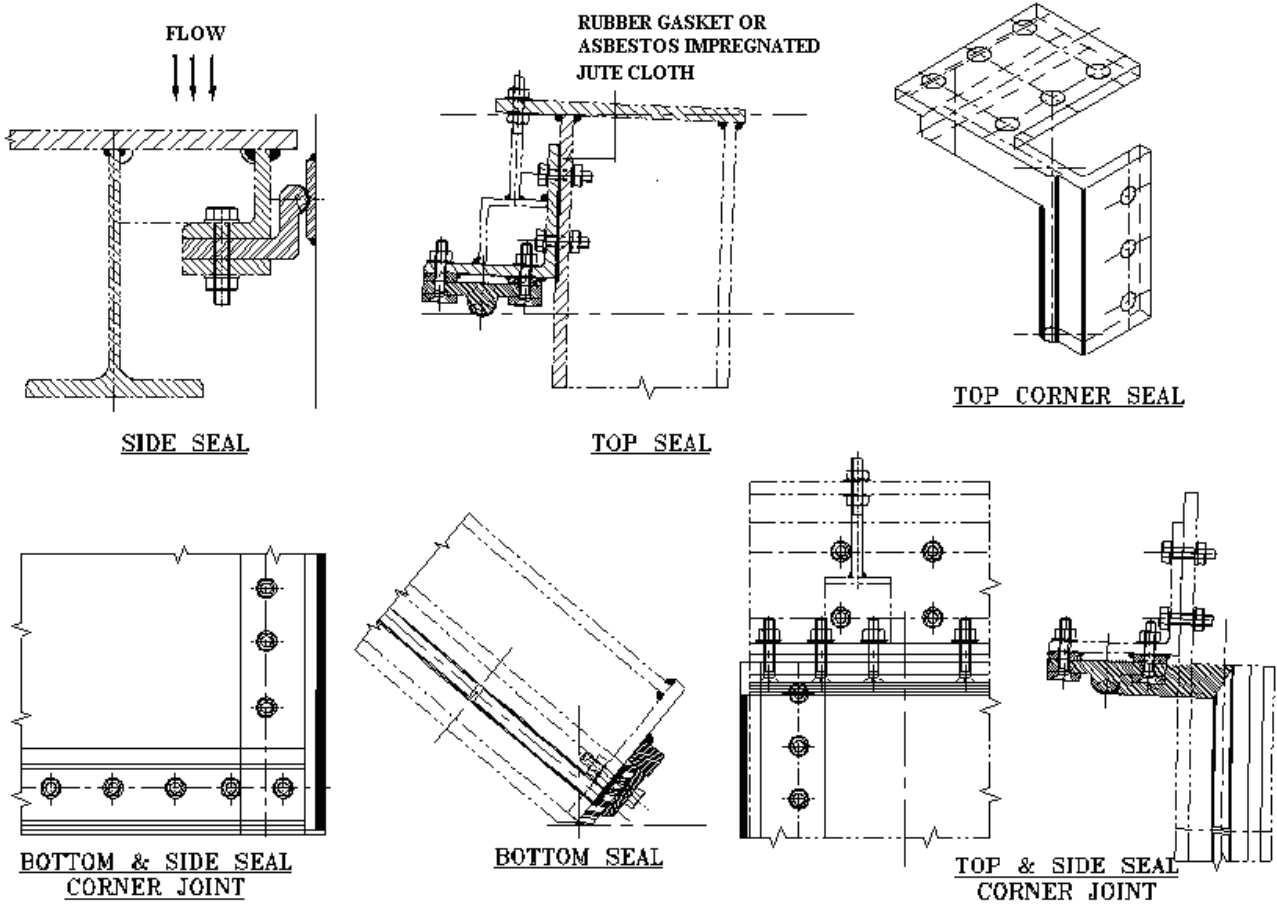

FIG 15 TOP, SIDE AND BOTTOM SEAL ARRANGEMENTS AND CORNER JOINTS
(IN RADIAL GATES)

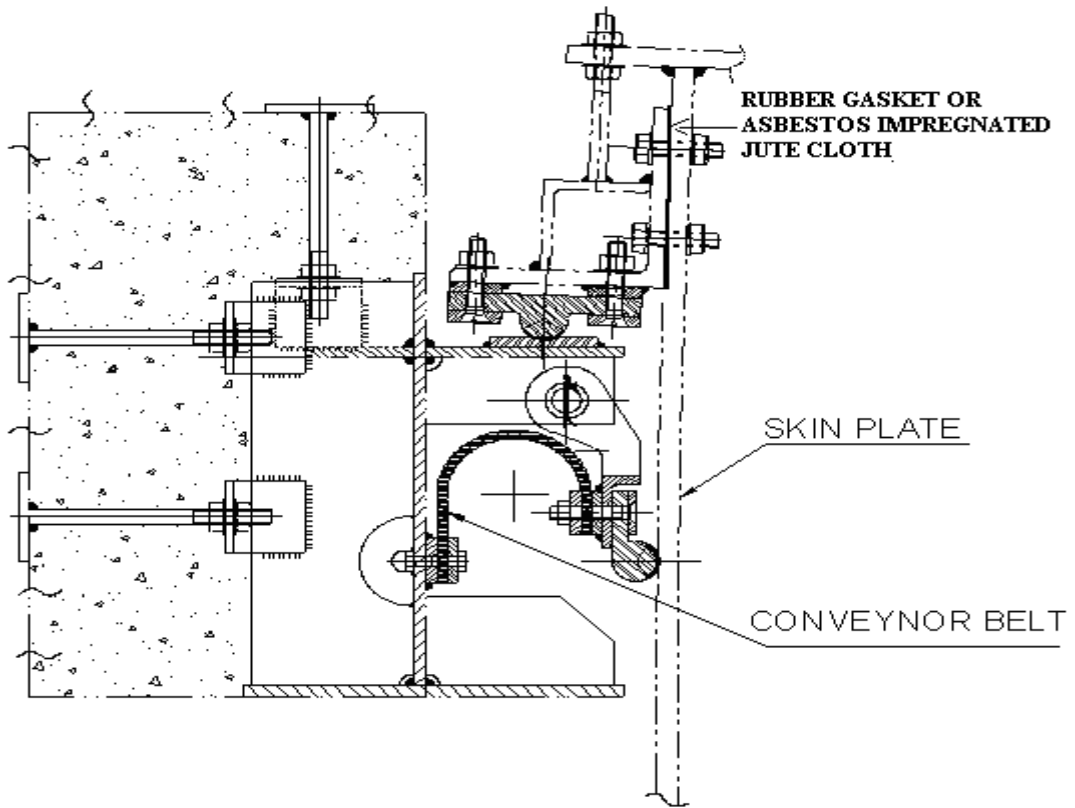

FIG 16A TOP SEAL AND ANTI JET SEAL WITH EMBEDDED PARTS TYPE-I

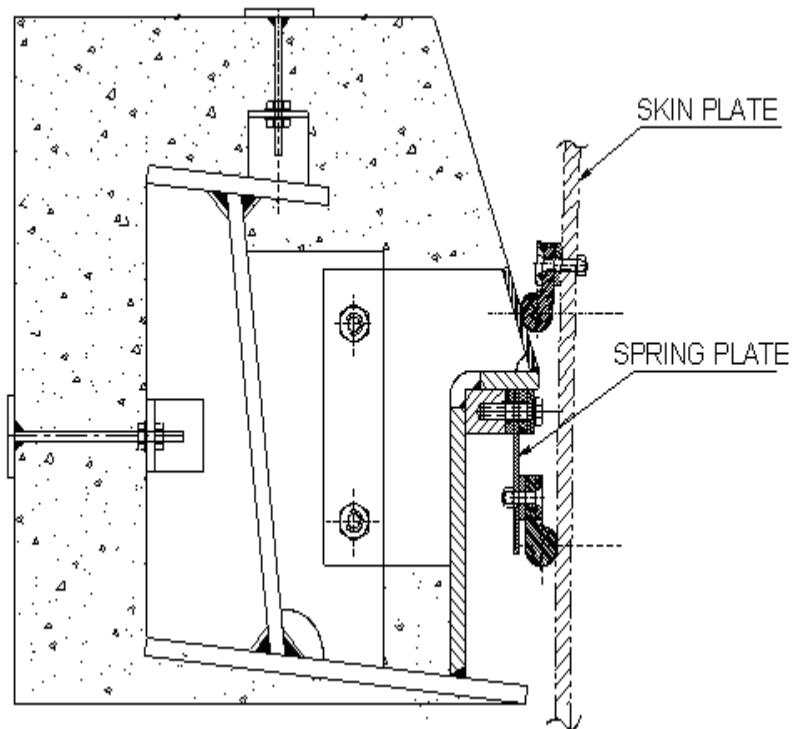

FIG 16B TOP SEAL AND ANTI JET SEAL WITH EMBEDDED PARTS TYPE-II

FIG 16 TYPES OF TOP SEAL AND ANTI JET SEAL WITH EMBEDDED PARTS

6.3 The seal should not fail in adhesion between the rubber and the cladding. The test should ensure adhesion bond of 176 N/cm width of the seal for a separation rate of 2.5 cm/min.

6.4 The test should ensure adhesion bond between the fluorocarbon and rubber as 54 N/cm width of the seal for a separation rate of 5 cm/min.

7 SAMPLING

For the purpose of ascertaining conformity to this standard the scale of sampling and criteria for conformity shall be as prescribed in Annex C.

8 MARKING

8.1 Each rubber seal or packing or both shall be marked indelibly with the,

- a) manufacturer's name or trade-mark;
- b) designation/Type of seal as per Table 2; and
- c) month and year of manufacture.

8.2 BIS Certification Marking

Each rubber seal or packing may be marked with the Standard Mark.

8.2.1 The use of Standard Mark is governed by the provisions of the *Bureau of Indian Standards Act, 1986* and the Rules and Regulations made thereunder. The details of conditions under which a licence for the use of the Standard Mark may be granted to manufacturers or producers may be obtained from the Bureau of Indian Standards.

ANNEX A
(Clause 1)**GUIDELINES FOR DESIGN AND USE OF DIFFERENT TYPES OF RUBBER SEALS****A-1 USES****A-1.1 Angle Shaped Seals**

This type of seal is used on gates on the crests of dams and weirs. The sealing effect is obtained partly due to initial interference with the embedded sealing plate and partly due to the deflection under load. The assembly details with angle shaped seal are shown in Fig. 10.

A-1.2 Flat/Wedge Seals

These seals are used generally as bottom seals for all types of gates and they seal against the bottom seating plate. They require high initial compression loading for proper seating. The assembly details with wedge type of seal are shown in Fig. 11 to Fig. 16. The initial compression should vary from 5 to 8 mm depending upon water head.

A-1.3 Music Note Seal

The arrangements of music note seal over the seal base plate are shown in Fig. 11 to Fig. 16.

The initial interference of music note type seal should vary from 2 to 5 mm depending upon the requirement and type of its installation at the discretion of the designer. The music note seal is generally recommended to be used on gates operated for head up to 30 m. The hollow bulb music note seal is recommended for gates operated at low head up to 15 m. A solid bulb music note seal is recommended for gates operated at medium head that is at a head of water exceeding 15 m but less than 30 m.

A-1.4 Double Stem or Caisson Seal

This type of seal is used for heads exceeding 30 m. The sealing will be obtained due to interference between the seal seat and the seal itself as well as deflection due to water pressure behind the seal in the space between the seal base plates. The arrangement of double stem seal over the seal base is shown in Figs. 12, 15 and 17.

The sealing bulb should project 6 mm beyond the face of the clamps. The initial interference of 2 to 5 mm between the plane of the sealing bulb and sealing face of the seal seat is usually provided.

These seals may be used as top, bottom and side seals either by using them with water pressure acting behind them which is withdrawn before the gate is moved to reduce/eliminate friction load or they may be used clad with fluorocarbon film to achieve the same purpose. On heavy gates such seals may be well used as bottom seals where enough mechanical compression becomes available to make a good seal.

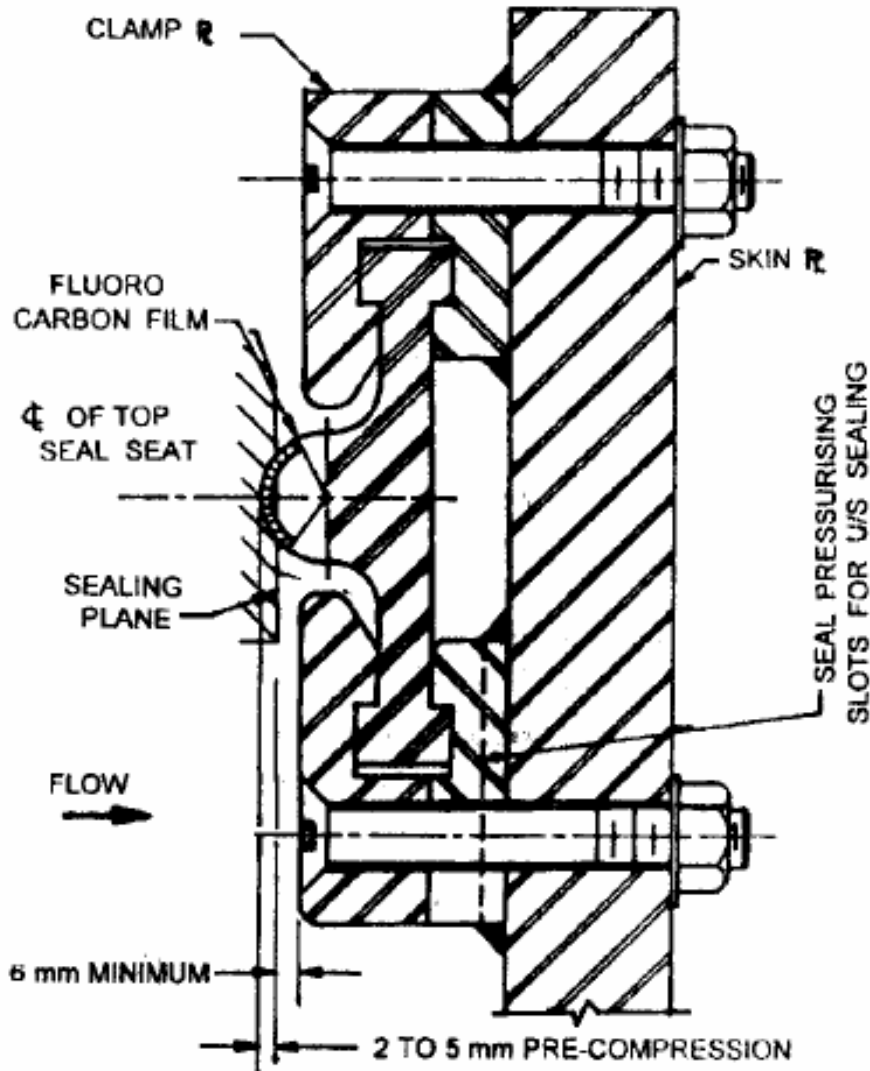

17A Assembly Details with Double Stem Seal
(Upstream Sealing)

FIG 17 A ASSEMBLY DETAILS WITH DOUBLE STEM SEAL (UPSTREAM SEALING)

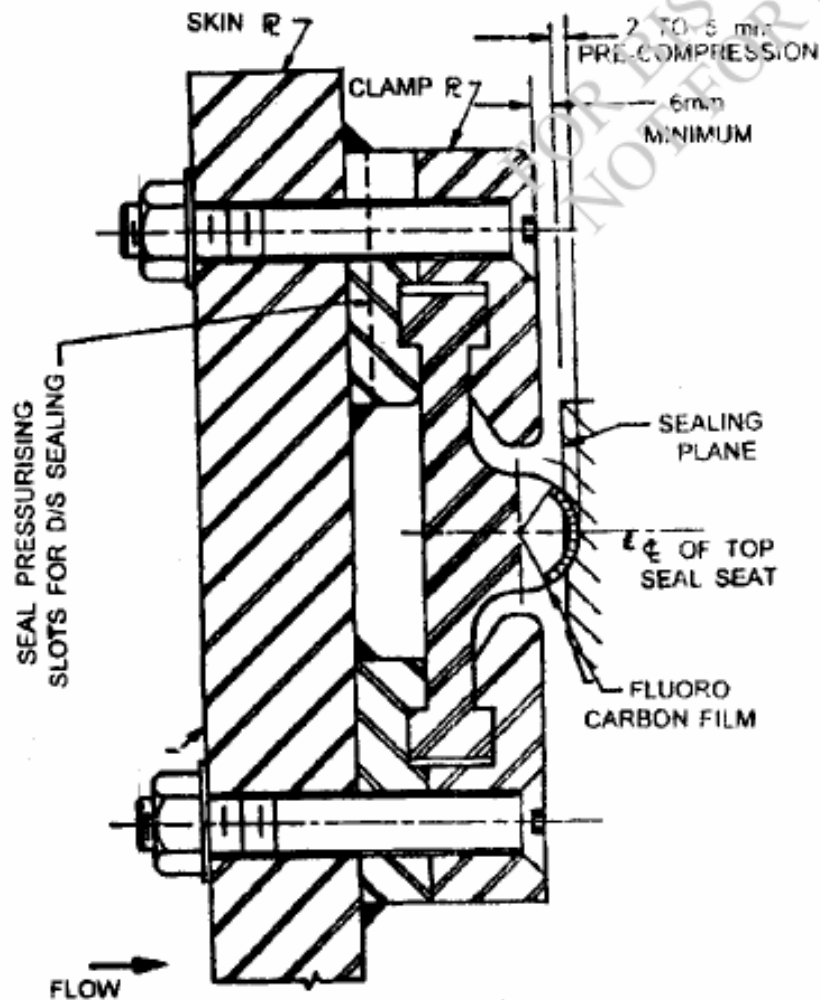

17B Assembly Details with Double Stem Seal
(Downstream Sealing)

FIG.17 DOUBLE STEM SEAL.

FIG 17B ASSEMBLY DETAILS WITH DOUBLE STEM SEAL (DOWNSTREAM SEALING)

FIG. 17 DOUBLE STEM SEAL

A-1.5 Double Bulb Seal

These type of seals are used where the gate is required to seal from both upstream or downstream side depending upon the requirement. These are normally used for installation such as lock gates, channel gates, etc.

A-2 FORCE ON SEALS DUE TO INTERFERENCE AND DEFLECTION

An estimation of the forces likely to develop in the seal due to compression on account of interference and due to deflection is indicated in the curve shown in Fig. 18 for the guidance of designer. However, actual values of the same as recommended by seal manufacturer based upon tests may also be adopted.

NOTES

- 1 For seal of other dimensions, value of force may be interpolated/extrapolated.
- 2 Applicable for both solid and hollow bulb.
- 3 Deflection X corresponding to pre-compression envisaged.

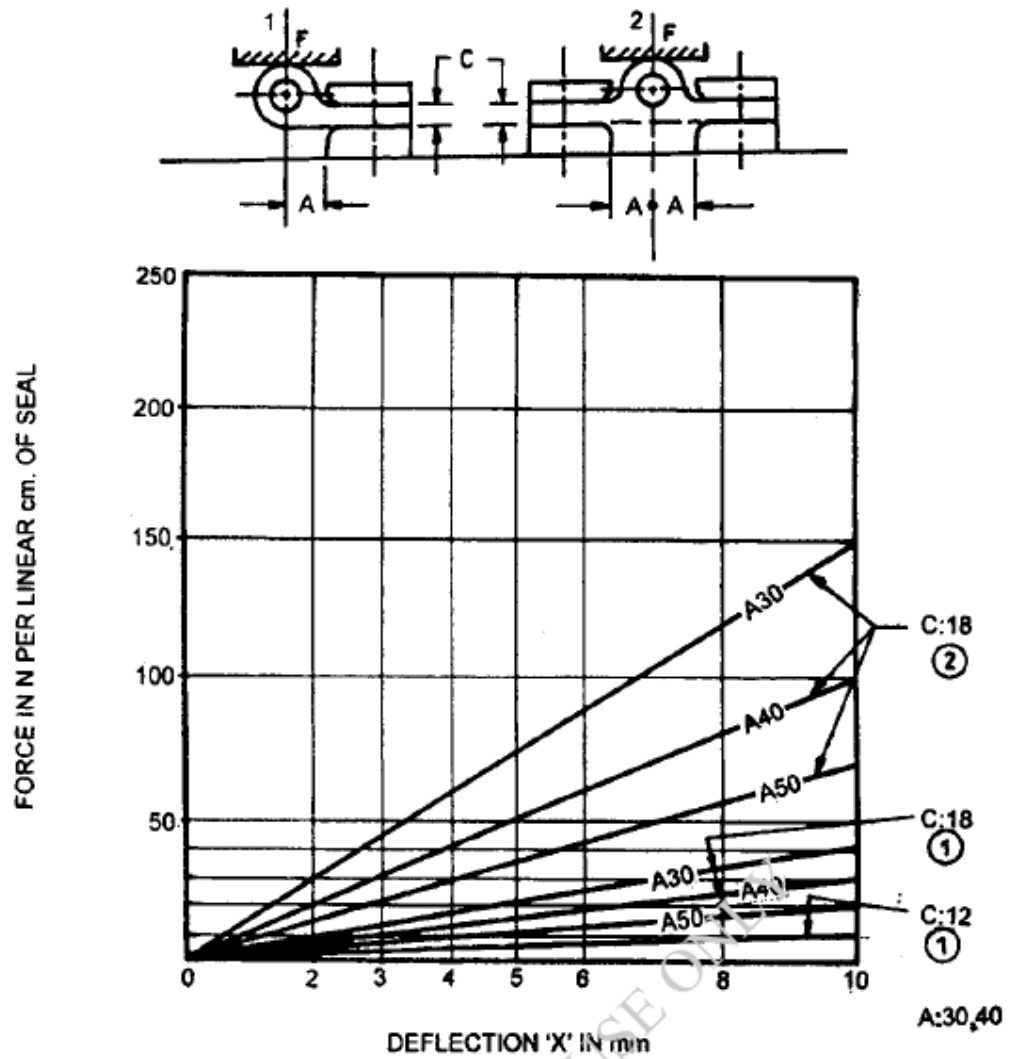

NOTES

- 1 For seals of other dimensions, values of force may be interpolated/extrapolated.
- 2 Applicable for both solid and hollow bulb.
- 3 Deflection X corresponds to pre-compression envisaged.

FIG. 18 FORCE DEVELOPED DUE TO DEFLECTION

FIG 18 FORCE DEVELOPED DUE TO DEFLECTION

A-3 FRICTION OF SEALS

A-3.1 The following values of coefficient of friction for seals may be adopted in general (unless otherwise determined by tests) in the design of gates and associated equipment:

Sl No.	Type of Seal	Coefficient of Friction	
		Static	Dynamic
(1)	(2)	(3)	(4)
i)	Rubber seal on stainless steel	1.5	1.2
ii)	Seals with fluorocarbon cladding on stainless steel	0.2	0.15

A-3.2 The area of loading to determine the frictional load on the seals should be as follows:

- a) *Caisson seal* — The area ($A \times \text{length}$) acted upon by water pressure behind the seal (see Fig. 18).
- b) *Music note seal* — The area ($A \times \text{length}$) of the seal acted upon by water pressure behind seal (see Fig. 18).

A-4 SPLICES

A-4.1 As far as practicable only vulcanized splices should be provided.

A-4.2 All splices in all rubber seals wherever practicable shall be on a 45° bevel as related to the thickness (not the width) of the seal.

A-4.3 The splice position should avoid bolt hole in web portion.

A-4.4 Cladded seals should not be bevelled. They should be square cut at right angle.

A-4.5 Field splices, if not vulcanized should never be made on a bevel. Pieces should be cut at a 90° and given an interference of not less than 2 mm so that when they are butted tightly (one to the other) they will not climb.

A-5 TRANSPORTATION, HANDLING AND STORAGE OF SEALS

A-5.1 Adequate care should be taken for proper packing of the rubber seals in black polythene rolls to avoid damage in transport and storage.

A-5.2 The seals should not be allowed to come in contact with any sharp edged or pointed objects or any abrasive surface that might cut or tear the rubber.

A-5.3 Direct sunlight, oxygen and ozone affects the physical properties of rubber and causes it to age more quickly. Seals, therefore, should be stored in a dark cool room in original packing.

A-5.4 It is suggested to leave the seals in the original packing, however, the seal should be unrolled and kept on a flat surface at least 48 h before installing it.

A-5.5 In no case the seals should be allowed to come in contact with oils or oil-emulsion solvent, during storage.

ANNEX B
(Table 1)**METHODS OF TEST FOR LOW TEMPERATURE BRITTLINESS****B-1 GENERAL**

This test method covers the determination of the lowest temperature at which the rubber vulcanizes.

B-2 PRINCIPLE

This test method covers the evaluation of rubber materials subjected to low temperature flexing with impact under well defined conditions of striker speed. The response is largely dependent on effects of low temperatures such as crystallization incompatibility of plasticizer or the inherent dynamic behaviour of the material itself. Data obtained by this test method may be used to predict the product behaviour in applications where the conditions are similar to those specified in the test method.

B-3 APPARATUS

B-3.1 Specimen Clamp — It is designed so as to hold firmly the specimen(s) as cantilever beams (see Fig. 19).

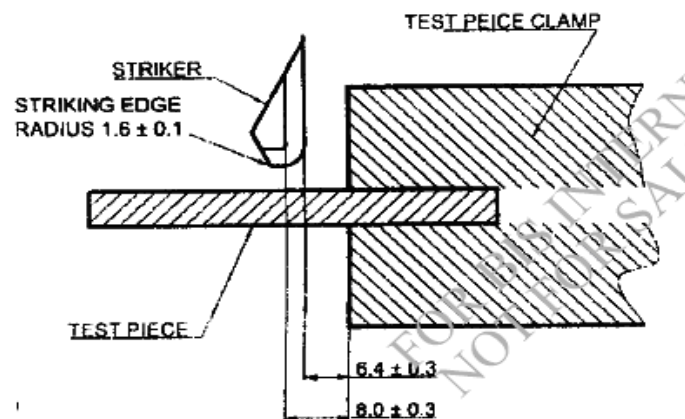

The test piece thickness is 2.0 ± 0.2 mm.

All dimensions in millimetres.

FIG. 19 SPECIMEN CLAMP AND STRIKER

The test piece thickness is 2.0 ± 0.2 mm.

All dimensions in millimetres.

FIG 19 SPECIMEN CLAMP AND STRIKER

B-3.2 Striker

The edge of the striker shall have a radius of 1.6 ± 0.1 mm. The edge shall move relative to the specimen at a rectilinear speed of 2.0 ± 0.2 m/s at impact and immediately after.

NOTE — The striker may be motor-driven, solenoid-operated, gravity-activated or spring loaded. The motor-driven tester should be equipped with a safety interlock to prevent striker motion when the cover is open.

B-3.2.1 *Position of Striking Edge*

The distance between the centre line of the striking edge and the clamps shall be 8.0 ± 0.3 mm. The clearance between the striking arm and the clamp at and immediately following impact shall be 6.4 ± 0.3 mm.

B-3.3 **Tank or Test Chamber**

A tank for liquid heat transfer media or a test chamber for gaseous media is required. To ensure thorough circulation of the heat transfer medium, a stirrer should be provided for liquids and a fan or blower for gaseous media.

B-3.4 **Heat Transfer Media**

B-3.4.1 *Liquid Heat Transfer Medium*

Methanol is the recommended heat transfer medium. Since methanol is flammable and toxic, the bath should be isolated in a closed hood.

NOTES

- 1 Any other liquid heat transfer medium that remains fluid at the test temperature and will not appreciably affect the material tested may be used.
- 2 The desired temperature may also be obtained by tilling the tank with the heat transfer medium and lowering its temperature by the addition of liquid carbon dioxide controlled by solenoid activated unit with an associated temperature control. Where temperatures below that obtainable by solid or liquid carbon dioxide are required, liquid nitrogen may be used.

B-3.4.2 *Gaseous Medium*

A gaseous medium may be used provided ample time is allowed for the specimens to reach temperature equilibrium with the temperature of the medium.

B-3.5 **Temperature Control**

Suitable means shall be provided for controlling the temperature of the heat transfer medium within ± 0.5 °C, if the medium is liquid and within ± 1 °C with gaseous medium.

B-4 **TIME LAPSE BETWEEN VULCANIZATION AND TESTING**

B-4.1 For all test purposes, the minimum time between vulcanization and testing shall be 16 h.

B-4.2 For product tests, whenever possible, the time between vulcanization and testing should not exceed three months. Tests should be made within two months of the date of receipt by the customer.

B-5 **TEST SPECIMENS**

The die punched Type A specimens as illustrated in Fig. 20 shall be used.

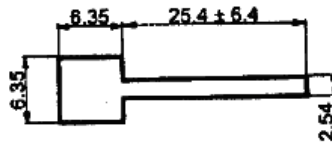

All dimensions in millimetres.
FIG. 20 TYPE A TEST PIECE

All dimensions in millimetres.

FIG. 20 TYPE A TEST PIECE

NOTE — Specimens of other than 2.0 ± 0.2 mm thickness may be used provided it can be shown that they give equivalent results for the material being tested.

B-6 CONDITIONING

Prepared test pieces shall be conditioned immediately before testing for a minimum of 16 h at a temperature of $27 \pm 2^\circ\text{C}$ and a relative humidity of 65 ± 5 percent.

B-7 PROCEDURE

B-7.1 Test with Liquid Heat Transfer Medium

B-7.1.1 Prepare and bring the bath to a temperature below the expected lowest temperature of non-failure. Place sufficient liquid in the tank to ensure approximately 25 mm liquid covering the test specimens.

B-7.1.2 Mount five type specimens in the apparatus with the entire tab in the clamp. Immerse the specimens for 3.0 ± 0.5 min at the test temperature.

B-7.1.3 After immersion for the specified time, record the actual test temperature and deliver a single impact to the specimens.

B-7.1.4 Examine each specimen to determine whether or not it has failed. Failure is defined as any crack, fissure, or hole visible to the naked eye or complete separation into two or more pieces. Where a specimen has not completely separated, bend it to an angle of 90° in the same direction as the bend caused by the impact, then examine it for cracks at the bend.

B-7.1.5 Repeat the test at next higher temperatures at 10°C intervals using new specimens each time until no failure is obtained. Then decrease the bath temperature at 2°C intervals. Test at each temperature to determine the lowest temperature at which no failure occurs. Record this temperature as the lowest temperature of non-failure.

B-7.2 Test with Gaseous Heat Transfer Medium

B-7.2.1 Adjust the refrigerating unit and bring the test chamber, test apparatus and specimens to the desired temperature.

B-7.2.2 The testing is performed as described in **A-7.1**.

B-8 REPORT

Report the following information:

- a) Thickness and type of specimen;
- b) No. of specimens tested at a single impact, if other than five;
- c) Conditioning period, method and procedure;
- d) Heat transfer medium; and
- e) Brittleness temperature to nearest 1°C.

ANNEX C
(Clause 7)**SAMPLING AND CRITERIA FOR CONFORMITY****C-1 SCALE OF SAMPLING****C-1.1 Lot**

In a consignment all the rubber seal of the same type, dimension, shape and manufactured from the same type of rubber under essentially similar conditions of production shall be grouped together to constitute a lot.

C-1.2 Samples shall be selected and tested from each lot separately for ascertaining its conformity or otherwise to the requirements of this specification.

C-1.3 The number of rubber seals to be selected at random from a lot for different tests shall depend upon the size of the lot and shall be in accordance with col 2 and col 3 of Table 3.

Table 3 Scale of Sampling and Permissible Number of Defectives
(Clause C-1.3)

SI No.	No. of Rubber Seals in Lot Size N	Number of Samples for Dimension		No. of Tests for Each Characteristic for Hardness, Tensile Strength, Elongation and Water Absorption	No. of Tests for each characteristic, for Ageing and Low Temperature Brittleness Test (See Tables 1 and 2)
		Sample Size (n)	Permissible No. of Defectives		
(1)	(2)	(3)	(4)	(5)	(6)
i)	Up to 100	5	0	3	1
ii)	101 - 150	8	0	3	1
iii)	151 - 300	13	0	3	1
iv)	301 - 500	20	0	3	1
v)	501 - 1 000	32	1	5	2
vi)	1 001 and above	50	2	8	3

C-1.3.1 The seals to be selected from the lot shall be chosen at random. In order to ensure the randomness of selection, random number tables shall be followed. In case random number tables are not available, the seals may be selected from the lot in the following manner:

Starting from any seal in the lot, the seals shall be counted as 1, 2, r and so on in one order, where r is the integral part of N/n (N and n being the lot size and sample size respectively). Every r^{th} the seal thus counted shall be withdrawn to constitute the sample.