

BUREAU OF INDIAN STANDARD
DRAFT FOR COMMENTS ONLY

(Not to be reproduced without the permission of BIS or used as an Indian Standard)

भारतीय मानक मसौदा
रेडियल गेट्स की संरचनात्मक डिजाइन के लिए अनुशंसाएँ

(IS 4623 का चौथा पुनरीक्षण)

Draft Indian Standard

RECOMMENDATIONS FOR STRUCTURAL DESIGN OF RADIAL GATES

(Fourth Revision of IS 4623)

Hydraulic Gates and Valves Sectional Committee,
WRD 12

Last Date for Comments:
21/08/2024

FOREWORD

(Formal Clause of the foreword will be added later)

This Indian Standard (Fourth Revision) was adopted by the Bureau of Indian Standards, after the draft finalized by the Hydraulic Gates and Valves Sectional Committee had been approved by the Water Resources Division Council.

Almost every river valley project has a reservoir or diversion work for the control of floods or to store water for irrigation or power generation or for both: A spillway with gates releases waters during excess inflow of water. Controlled release of water is also affected by control gates provided in conduits in the body of the dam or tunnel. One of the methods for providing such control in spillways is sluice conduits and radial gates in canals.

A radial gate, as its name implies, is in the shape of a portion of a cylinder rotating about a horizontal axis. Normally, the water is against the convex side of the gate but sometimes in the case of canal gates, water load is applied on the concave side also.

Among various types of gates for regulation of crest spillway, radial gate is generally economical for large size and usually suitable type because of its simple design, light weight, low hoist capacity requirement, better discharge characteristics, etc.

This standard was first published in 1967. The first revision was prepared in the light of the experience gained in usage of the standard during course of these years. In the first revision number of changes were made; the prominent among which were (a) revision of permissible stresses of various materials linking them with ultimate tensile stress or yield

point of the material, (b) provision for ice load, (c) provision in the design for the occasional overtopping of the gate during floods, and (d) permissible tolerances to be maintained for embedded parts and components of gates.

The second revision of the standard was brought out in 1984. The important updation carried out were:

- a) Two more conditions were included in Annex C, that is, three edges fixed and one (longer) edge free and three edges fixed and one (shorter) edge free to cover the most commonly occurring field conditions; and
- b) Permissible tolerances for components of gate were modified based on the experience gained since the first revision of the standard was published.

The third revision was brought out in 2000 to incorporate changes and additional clauses in the light of experience gained and the latest trends in design specially with reference to pre-stressed anchorages, bearings for the trunnions, types of hoists, de-icing arrangement, etc.

The fourth revision of this standard has been brought out to update the standard in the light of experience gained and the latest trends in design. The major changes incorporated on this revision are:

- a) Annex B on recommended material for different components has been updated,
- b) Table 1 to Table 3 have been updated in line with IS 4622,
- c) Annex C has been updated in line with IS 4622,
- d) Recommended materials for components of gate have been updated with addition of new materials,
- e) Fig. 3 of radial gate and its components have been updated, and
- f) Silt loading has been taken into consideration

For the purpose of deciding whether a particular requirement of this standard is complied with, the final value, observed or calculated, expressing the result of a test or analysis, shall be rounded off in accordance with IS 2: 2022 'Rules for rounding off numerical values (*second revision*); The number of significant places retained in the rounded off value should be the same as that of the specified value in this standard.

Draft Indian Standard**RECOMMENDATIONS FOR STRUCTURAL DESIGN OF RADIAL GATES***(Fourth Revision of IS 4623)*

**Hydraulic Gates and Valves Sectional Committee, WRD
12****Last Date for Comments:
21/08/2024**

1 SCOPE

This standard provides criteria for the structural design of radial gates.

2 REFERENCES

The Indian Standards listed in Annex A contain provisions which through reference in this text constitute provisions of this standard. At the time of publication, the editions indicated were valid. All standards are subject to revision and parties to agreements based on this standard are encouraged to investigate the possibility of applying the most recent editions of the standards.

3 GENERAL

3.1 Size of gate shall be specified as the clear width of opening and the vertical height above the sill of the gate up to the FRL or the top of the opening as the case may be.

3.2 Normally, the radial gate has an upstream skin plate bent to an arc with convex surface of the arc on the upstream side (see Fig. 1 and 2). The centre of the arc is at the centre of the trunnion pins, about which the gate rotates. The skin plate is supported by suitably spaced stiffeners either horizontal or vertical or both. If horizontal stiffeners are used, these are supported by suitably spaced vertical diaphragms which are connected together by horizontal girders transferring the load to the two end vertical diaphragms. The end beams are supported by radial arms, emanating from the trunnion hubs located at the axis of the skin plate cylinder. If vertical stiffeners are used, these are supported by suitably spaced horizontal girders which are supported by radial arms. The arms transmit the water load to the trunnion/yoke girder. Suitable seals are provided along the curved ends of the gate and along the bottom. If used as a regulating gate in tunnels or conduits, a horizontal seal fixed to the civil structure, seals with the top horizontal edge of the gate, in the closed position. The upstream face of the gate rubs against the top seal as the gate is raised or lowered (see Fig. 3). Guide rollers are also provided to limit the sway of the gate during raising or lowering.

3.3 The trunnion anchorage comprises essentially of a trunnion/yoke girder, held to the concrete of the spillway piers or the abutments by anchor rods or plate sections designed to resist the total water thrust on the gate. The trunnion or yoke girder is usually a built-up section to which the anchors are fixed.

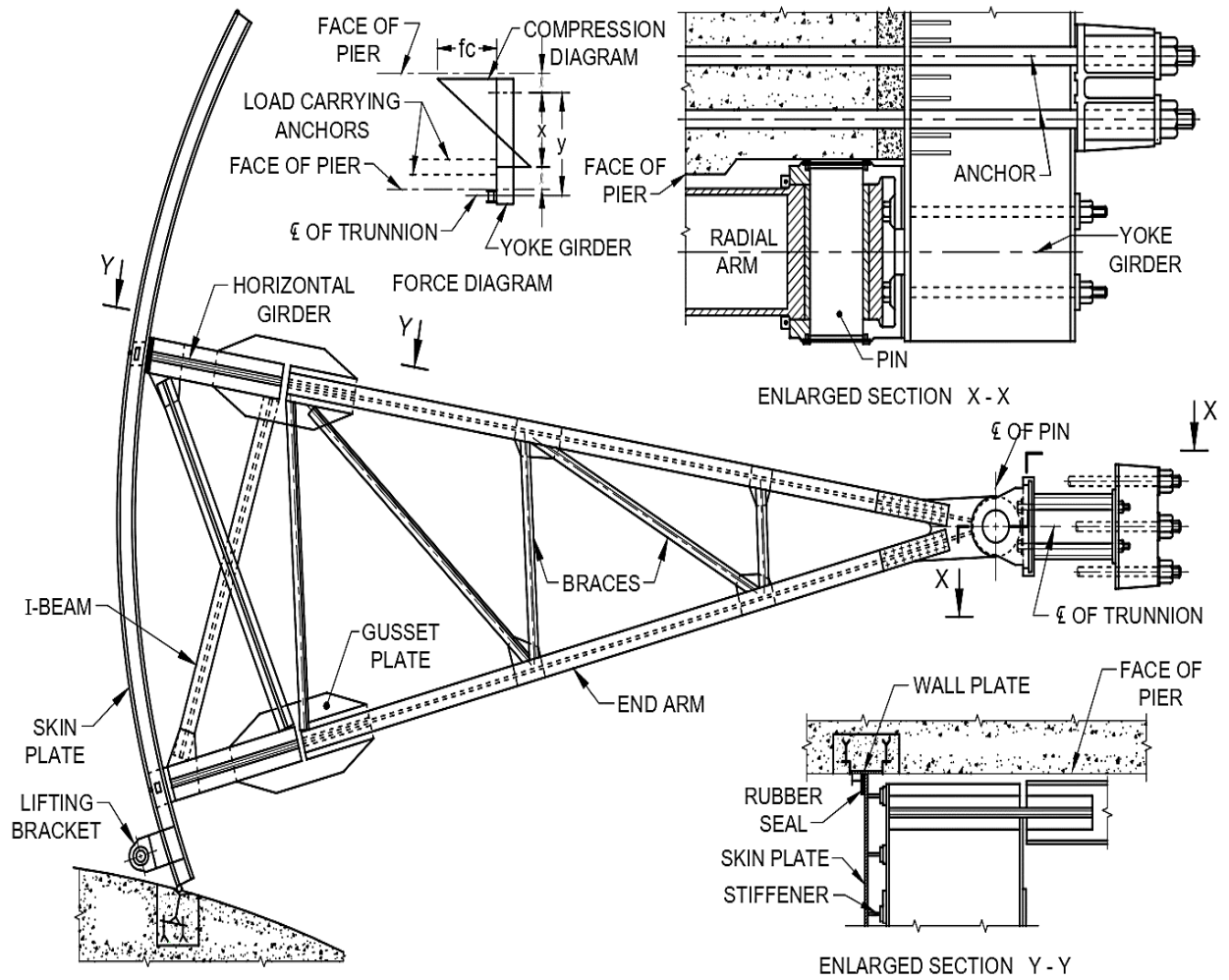
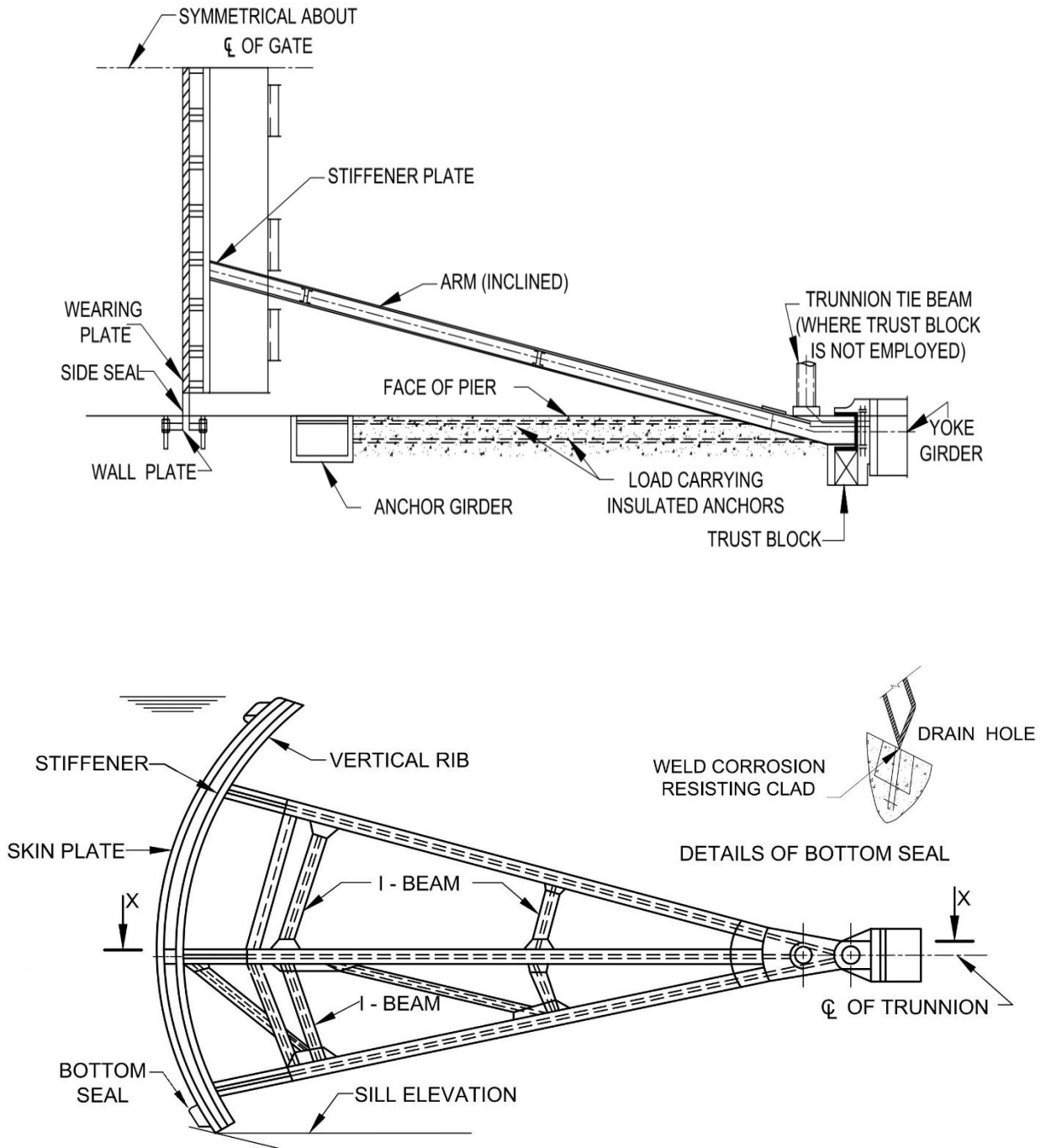

FIG. 1 ILLUSTRATIVE DIAGRAM FOR CREST TYPE RADIAL GATE WITH PARALLEL ARM



(A) CREST TYPE RADIAL GATE WITH INCLINED ARM

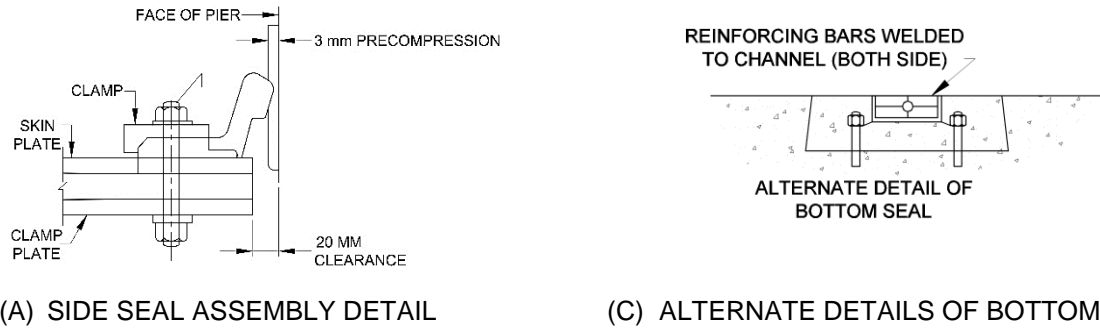
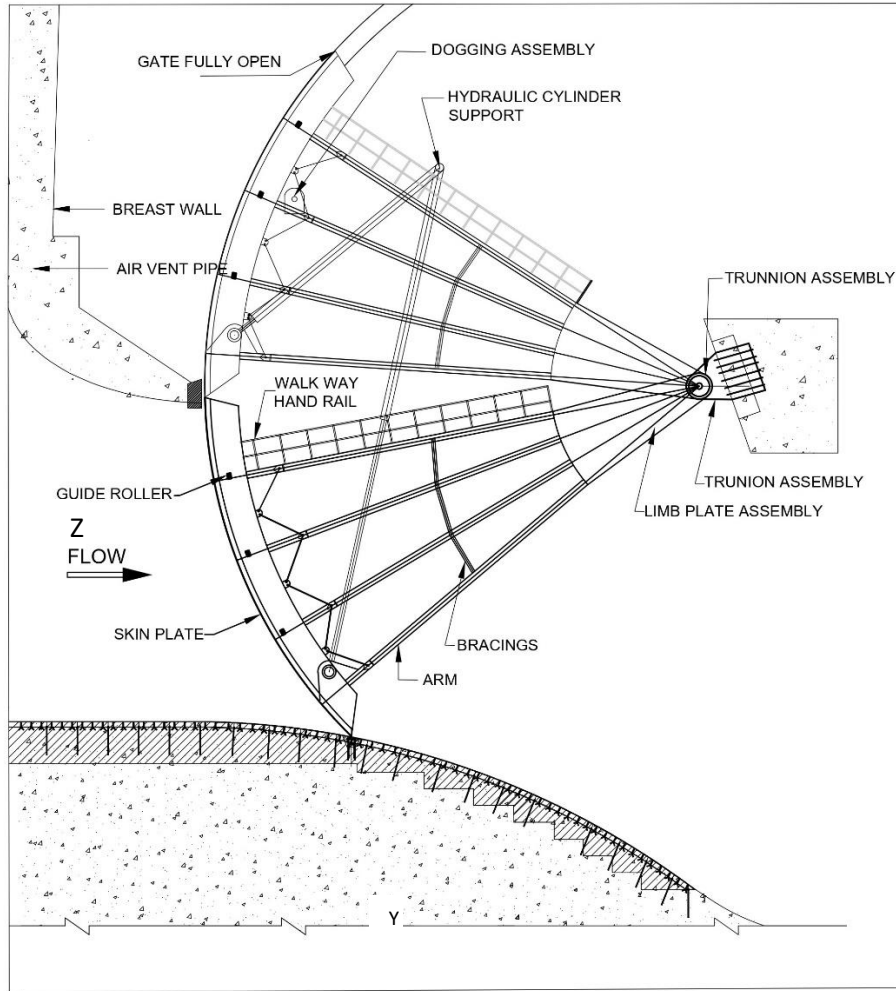

FIG. 2 ILLUSTRATIVE DIAGRAM FOR CREST TYPE RADIAL GATE WITH INCLINED ARM

3.3.1 The thrust may be distributed in the concrete either as bond stress along the length of the anchors (see Fig. 1) or as a bearing stress through the medium of an embedded anchor girder at the upstream end of the anchors. In the latter case the anchors are insulated from the surrounding concrete (see Fig. 2).

3.3.2 Alternatively, anchorages of radial gates could also comprise of pre-stressed anchorage arrangement. This system is especially advantageous in the case of large sized gates where high loads are required to be transferred to the piers and the system of anchorages mentioned in 3.3.1 is cumbersome and tedious. In that case pre-stressed anchorages, post tensioned steel cables or rods are used which when subjected to water thrust release pressure from concrete as higher tensile stresses carried by anchorages. A typical arrangement is indicated in Fig. 4.



(A) SECTIONAL VIEW OF SLUICE RADIAL GATE

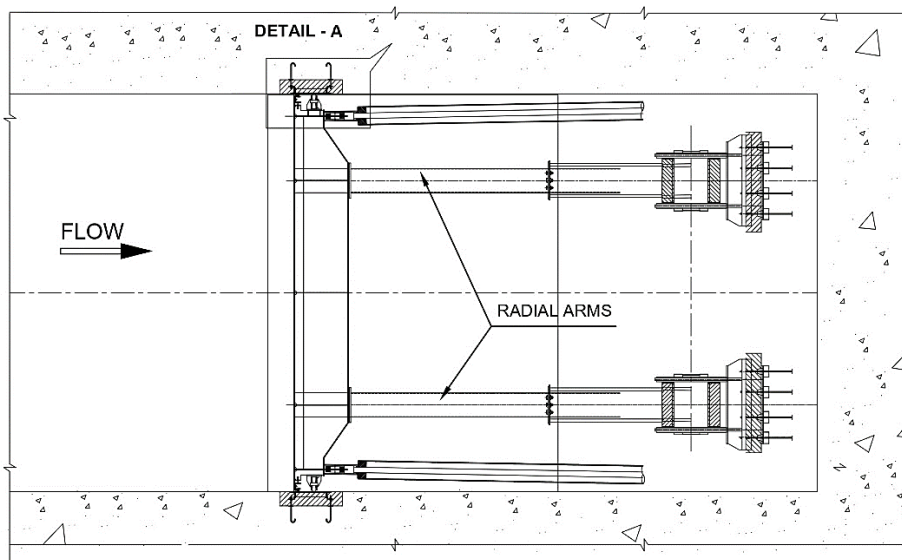

(B) PLAN VIEW OF SLUICE RADIAL GATE

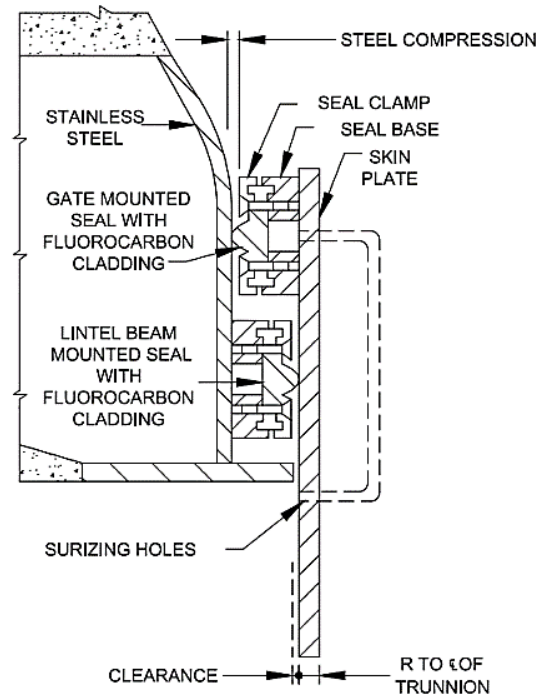

(C) DETAILS OF TOP SEAL

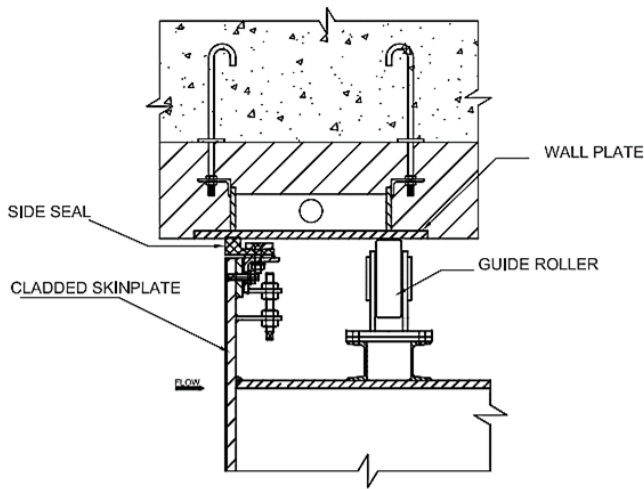

DETAIL - X

(D) SIDE SEAL AND GUIDE ROLLER

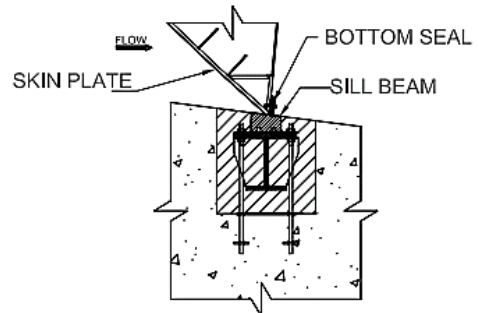

DETAIL - Y

(E) BOTTOM SEAL WITH SILL BEAM

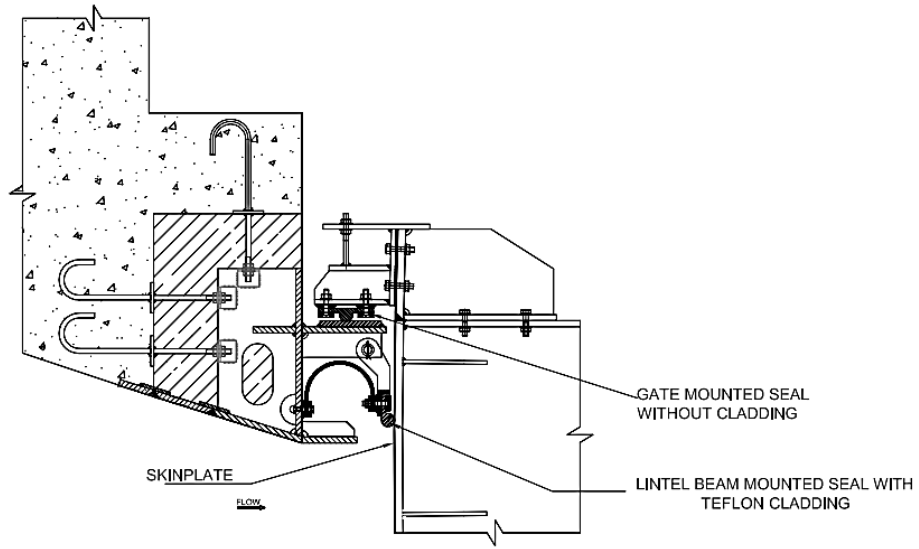

(E) TOP SEAL WITH SKIN PLATE

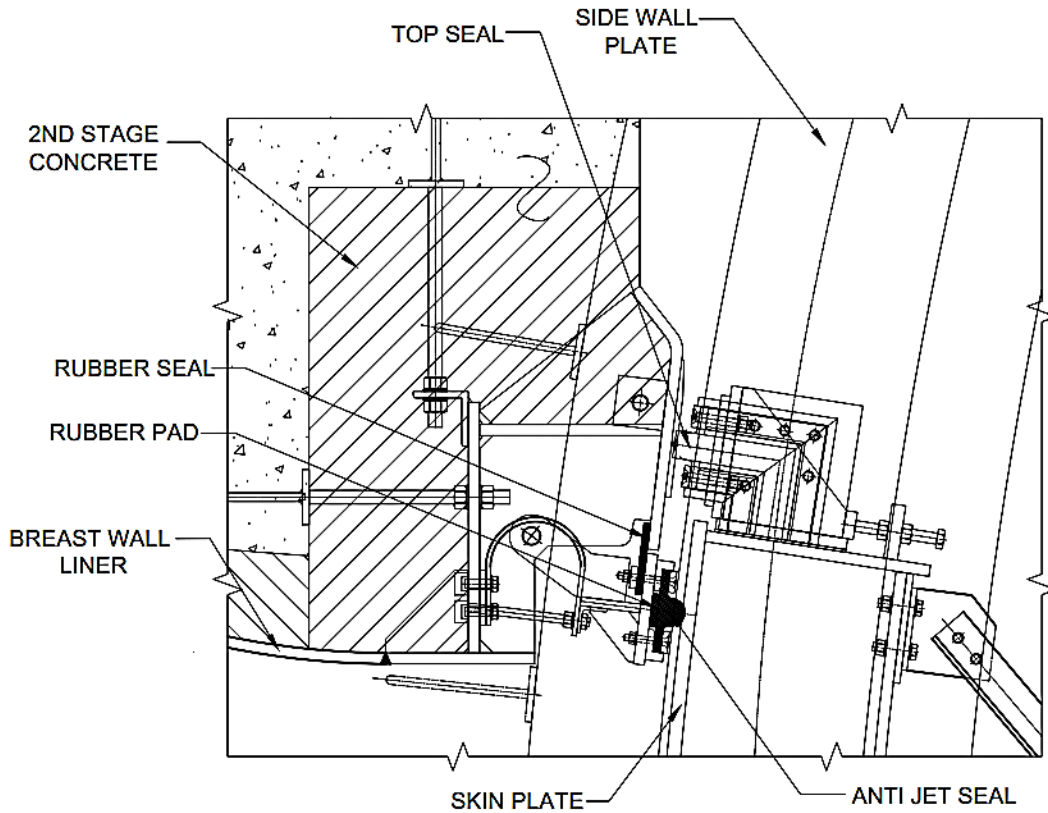

(F) ARRANGEMENT OF TOP SEAL

FIG. 3 ILLUSTRATIVE DIAGRAM FOR SLUICE/CONDUIT RADIAL GATES

3.3.2.1 The actual final stress developed in the cables/ rods after allowing for all losses should not exceed 60 percent of the UTS or 80 percent of the YP of the material.

3.3.3 The minimum grade of concrete as per IS 456 around the anchorage system shall be as follows:

- a) M-25 for Conventional anchorage system as per **3.3.1**; and
- b) M-35 for Pre-stressed anchorages system as per **3.3.2**.

3.4 When the thrust is distributed in the concrete through bond action, the anchorage girder is used to support the trunnion bracket. In the other case, another anchorage or support girder, in addition to the yoke girder supporting the load carrying anchors, is used to support the trunnion bracket.

3.5 If inclined radial arms are used instead of parallel arms, a side thrust block is provided to resist the side thrust. Alternatively, a trunnion tie is also used for the same purpose (see Fig. 2) or the lateral thrust may be directly transferred to the concrete pier through bearing from plate embedded in the concrete.

3.6 For smooth hoisting of gates in sub-freezing weather, provision for de-freezing should be made (see IS 10021).

3.7 Whenever occasional overtopping of gate is expected provision of hood, shield and flow breakers may be considered by the designer.

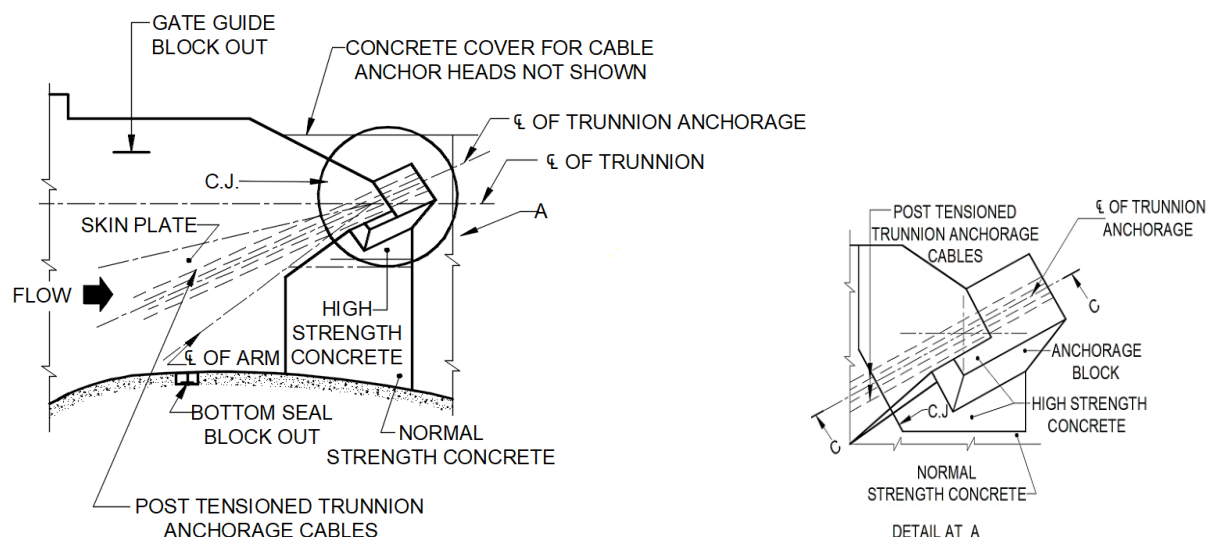

(A) ELEVATION SHOWING TRUNNION ANCHORAGE OF SPILLWAY RADIAL GATE

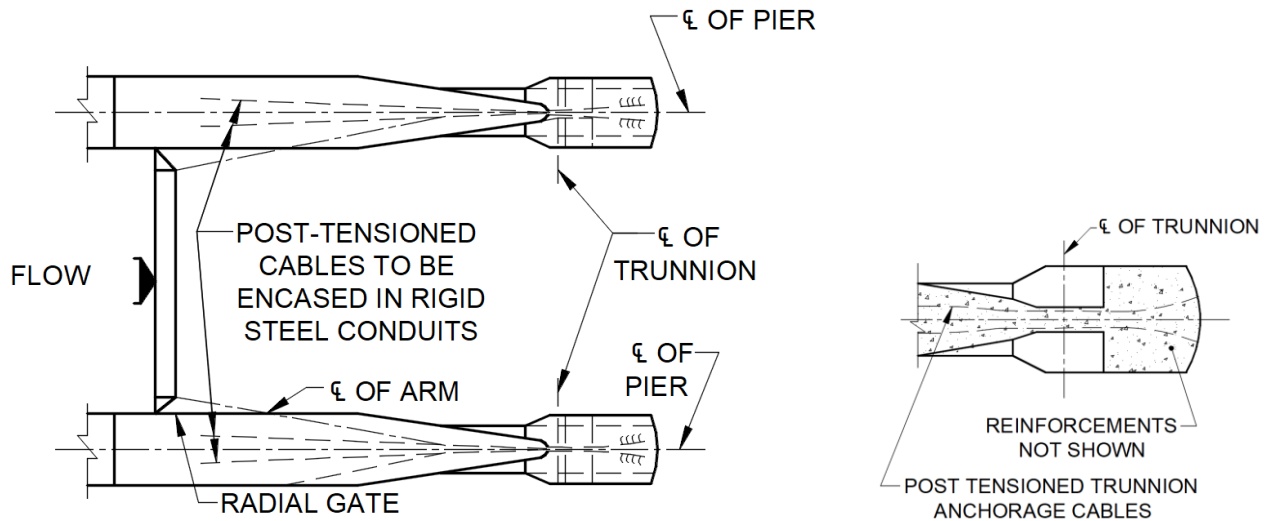

(B) PLAN OF PEIRS SHOWING ANCHORAGER

FIG. 4 TRUNNION ANCHORAGE OF SPILLWAY RADIAL GATE

3.8 Hydraulic hoist operated flap gates may be provided at the top of large size radial gates for passing floating debris.

4 CLASSIFICATIONS OF GATES

The gates may be classified as follows:

- a) Crest gates — For use in spillways;
- b) Conduit gates — For use in conduits, sluices and tunnels; and
- c) Canal gates — For use in canal regulators.

5 MATERIALS

The different materials recommended for components of radial gates is given in Table 1.

Table 1 Material for Components of Radial Gates

(Clause 5)

Sl. No.	Component	Recommended Materials	Ref. to Indian Standard
(1)	(2)	(3)	(4)
i)	Skin plate	Structural steel	6911
ii)	Stiffeners, horizontal girders, arms, bracings, tie members, anchorage girder, yoke girder, embedded girder, rest girder, load carrying anchors	Structural steel	2062
iii)	Guide rollers	Cast steel	1030
		Structural steel	2062
		Forged steel	2004
		Cast iron	210
iv)	Trunnion, hub and bracket	Cast steel Structural steel	1030 2062
v)	Pin	Corrosion resistant steel	3444
		Cast steel*	1030
		Stainless Steel	6603
vi)	Bushing	Bronze/self-lubricating bushing	305 306 318
vii)	Seal seat	Stainless steel Plate	6911
viii)	Seal base, seal-seat base and sill beam	Structural steel	2062
ix)	Pre-stressed anchor rods/cable	—	—
x)	HDPE sheath	—	—
xi)	Corrosion resistant grease	—	—
<p>NOTES</p> <p>1 Grade of the material conforming to specification mentioned above shall be specified by the designer to suit the requirement.</p> <p>2 *Material used for making pins will be electroplated with chromium in accordance with IS 1068.</p> <p>3 In case of radial gates in conduits being used as high pressure regulating gate with the top seal fixed on civil structure, the skin plate shall be of stainless steel or stainless steel cladded plate with minimum 4 mm thick cladding.</p>			

6 DESIGN CONSIDERATIONS

6.1 The design of the gate involves the following:

- a) The fixing of the following parameters:
 - 1) Location of the trunnions,
 - 2) Radius of the gate,
 - 3) Location of the sill, and
 - 4) Location and type of hoists.

- b) The design of the following component parts:
 - 1) Skin plate and stiffeners,
 - 2) Horizontal girders,
 - 3) Arms,
 - 4) Trunnion hub,
 - 5) Trunnion pin,
 - 6) Trunnion bush or bearing,
 - 7) Trunnion brackets,
 - 8) Trunnion girder or yoke girder,
 - 9) Load carrying anchors,
 - 10) Anchorage girder,
 - 11) Thrust block (if inclined arms are used),
 - 12) Trunnion tie (if inclined arms are used),
 - 13) Seals,
 - 14) Seal seat, seal base and sill beam
 - 15) Guide roller, and
 - 16) Anchor bolts.

6.1.1 The crest gate should generally be self-closing. The closing moment provided by the moving parts of the gate in any position should always be greater than the forces opposing the closure movement of the gate whether it is with the top seal against a breast wall or without top seal. However, for conduit gates, it may become necessary to provide a positive thrust for closing, in which case the hoist provided shall be suitable for the purpose.

6.1.2 The gate, in general, shall satisfy the following requirements:

- a) It shall be reasonably watertight, the maximum permissible leakage being not more than 5 liters/min/m length of seal in case of crest gates and medium head conduit gates and 10 liters/min/m length of seal in case of high heads gates. The figure of permissible leakage is the upper limit before which remedial measures shall be required to rectify defects,

- b) It shall be capable of being raised or lowered by the hoist at the specified speed,

- c) Power operated gates shall normally be capable of operation by alternate means in case of power supply failure, and

- d) If meant for regulation, it shall be capable of being held in position within the range of travel to pass the required discharge without cavitation and undue vibration.

6.2 Location of the Trunnions

6.2.1 The trunnions of the gate shall be so located that under conditions of maximum discharge over the spillway, they should remain at least 1.5 m clear of the water profile and should in no case be allowed to submerge in the flowing water. In case of radial gates in conduits the trunnion should be located above the roof level, that is, out of the path of the flow. However, in conduits, tunnels or in canals sometimes the trunnion may have to remain submerged in water. Under such conditions, suitable precautions should be taken to prevent corrosion of the trunnion parts, entry of silt between the moving parts, etc.

6.2.2 The trunnions of crest radial gates shall be so located that the resultant hydraulic thrust through the gate in the closed position for full reservoir condition lies as close to the horizontal as possible. This will reduce the upward or downward force that will otherwise be imposed on the anchorage system.

6.2.3 In case of conduits and tunnels, the trunnion shall be located clear of the water profile under free flow conditions. However, in case of pressure conduits it shall be designed for submerged condition in accordance with **6.2.1**.

6.2.4 The location of the trunnions shall be so as to allow the gate to be fully raised or lowered without interfering with the spillway or hoist bridge or any other part of the civil structure housing the gate.

6.3 Radius of the Gate

The radius of the crest gate, that is, the distance from the centre of the trunnion pins to the inside face of the skin plate shall be as far as possible, vary from H to $1.25 H$ consistent with the requirements of the trunnion location given in **6.2**, where H is the vertical distance between the top of the gate and the horizontal line through the sill.

In case of sluice radial gate, radius of the gate may be up to $1.5 H$ as the trunnion location is generally kept at higher elevation. Where, H is vertical height above sill of the gate to the top of opening.

6.4 Location of the Sill

6.4.1 The sill of the gate shall preferably be located slightly downstream of the crest, to avoid cavitation of the downstream glacis.

6.4.2 The sill shall, as far as possible, be located so that a vertical plane tangent to the upstream face of the skin plate will intersect the spillway at or downstream from the crest. This requirement would place the sill downstream of the crest. Operating clearances from the bridge and the location of the hoist may require the sill to be shifted further downstream.

6.4.2.1 For gates in canals, tunnels and conduits, the high location of the trunnions shall fulfill the requirement of **6.2.1** and **6.2.3**. The requirement given in **6.4.1** and **6.4.2** shall not apply and sill may be fixed as per the individual conditions.

6.4.3 The distance from the centre line of crest to the centre line of the sill shall be as small as possible in order to economize on the height of gate and pier size.

6.5 Location of Hoist

6.5.1 The radial gates are generally operated either by rope drum/chain hoists or by hydraulic hoist. For regulating gates in conduits/tunnels hydraulic hoists are preferred whilst for crest gates or canal gates either of the two may be suitable.

6.5.2 In case of crest gates or canal gates, the hoists may be installed on the roadway or on the piers or on an under-deck below the roadway.

6.5.3 The hoist shall be so located, that, as far as possible, the hoisting force is applied to the gate at the largest possible radius and the hoisting angle does not change much during the travel of the gate.

6.5.4 In the case of hydraulic hoist the connection to the gate is on the downstream of the skin plate while in the case of rope drum hoist the same is generally preferred on the upstream of the skin plate. In case of the rope drum hoist the hoisting, connection can also be located on the downstream side of the gate depending on the site requirements. However, in such a case a minimum of two ropes shall be connected to each drum.

6.5.5 When the hoists have to be installed in an underground chamber above the conduit these shall be so located that they remain sufficiently clear of water spray, for all positions of the gate. The requirements of the **6.5.3** shall also apply where such gates are subjected to high heads (30 m and above) regulation duty and vibrations, hydraulic hoists may invariably be used.

6.6 Skin Plate and Stiffeners

6.6.1 The skin plate and stiffeners shall be designed together in a composite manner.

6.6.2 The skin plate shall be designed for either of the following two conditions unless more precise methods are available:

- a) In bending across the stiffeners or horizontal girders as applicable, or
- b) As panels in accordance with the procedure and support conditions given in Annex C.

6.6.3 The minimum thickness of skin plate that maybe used in gates is 8 mm excluding corrosion allowance. However, in the case of large size crest gates because of the constant span under varying loading on the skin plate, it is economical to use two or more

thickness of the plates at different sections. For smaller gates as in canals tunnels and conduits the same thickness of plate can preferably be used throughout.

6.6.4 The stresses in skin plates for conditions given in **6.6.2** shall be determined as follows:

- a) For determining the stresses for conditions in bending across stiffeners or horizontal girders as per the procedure in **6.6.2** (a) bending moment shall be determined according to the conditions of supports; and
- b) For calculating the stresses in skin plates for bending as panel in accordance with the procedure given in **6.6.2** (b) and the stresses as given in Annex C shall be used.

6.6.5 In either of the cases specified in **6.6.2** while designing the stiffeners and horizontal girders the skin plate can be considered Coacting with them.

- a) The coacting width of the skin plate in non-panel fabrication as per **6.6.2** (a) shall be taken by restricting to the least of the following values:
 - i) $40 t + B$
where,
 t = thickness of skin plate, and
 B = width of the stiffener flange in contact with the skin plate.
 - ii) 0.11 span, and
 - iii) Center to center of stiffeners and girders.
- b) The width of the skin plate coacting with beam or stiffeners in panel fabrication as per **6.6.2** (b) shall be worked out as illustrated in Annex D and stresses due to beam action be calculated.

6.6.6 The stresses so computed shall be combined in accordance with the formula:

$$\sigma_v = \sqrt{\sigma_x^2 + \sigma_y^2 - \sigma_x \sigma_y + 3\tau_{xy}^2}$$

σ_v = combined stress,

σ_x = sum of stresses along x axis,

σ_y = sum of stresses along y axis, and

τ_{xy} = sum of shear stresses along x - y plane,

NOTE – The appropriate signs should be taken for σ_x and σ_y in the above formula.

6.6.7 The permissible value of mono-axial as well as combined stresses should not be greater than those specified in Annex B.

6.6.7.1 Permissible value of stresses in welds shall be the same as permitted for the parent material. For site weld the efficiency should be considered 80 percent of shop weld.

6.6.8 To take care of corrosion, the actual thickness of skin plate to be provided shall be at least 1.5 mm more than the theoretical thickness computed based on the stresses specified in Annex B. The minimum thickness of the skin plate shall not be less than 8 mm, exclusive of corrosion allowance.

6.6.9 The stiffeners may, if necessary, be of a built-up section or of standard rolled section, that is, tees, angles, channels, etc.

6.7 Horizontal Girders

6.7.1 The number of girders used shall depend on the total height of the gate but shall be kept minimum to simplify fabrication and erection and to facilitate maintenance. As a general thumb rule the number of horizontal girders and correspondingly number of arms for crest gate may be adopted as follows:

- | | |
|--------------------------------------|-----------|
| a) For height of gate up to 8.5 m | 2 No. |
| b) For height between 8.5 m and 12 m | 3 No. |
| c) For heights above 12 m | 4 or more |

6.7.2 In the case of the vertical stiffeners designed as a continuous beam the girders may be so spaced that bending moment in the vertical stiffeners at the horizontal girders are about equal.

6.7.3 When more than three girders are used, it may become necessary to allow the bending moment in the vertical stiffener at the top most girder, of a value higher than at the other girders, so as to adequately stress the skin plate, as given in **6.6.6**.

6.7.4 The girders shall be designed taking into consideration the fixity at arms support. Where inclined arms are used, the girders should also be designed for the compressive stress induced.

6.7.5 The girders shall also be checked for shear at the points where they are supported by the arms. The shear stress shall not exceed the value specified in Annex B.

6.7.6 Stiffeners and Bracings for Horizontal Girders

The horizontal girder should also be suitably braced to ensure rigidity. The spacing and design of the bearing and intermediate stiffeners shall be governed by relevant portions of IS 800.

6.8 Arms

6.8.1 As many pairs of arms as the number of horizontal girders, shall be used, unless vertical end girders are provided.

6.8.2 The arms may be straight or parallel. Inclined arms may conveniently be used to economize on the horizontal girders where other conditions permit.

6.8.3 The arms shall be designed as columns for the axial load and bending moment transmitted by the horizontal girders and shall be in accordance with IS 800 taking into consideration the type of fixity to the girder.

6.8.4 The total compressive stress shall be in accordance with IS 800 for various values of l/r where l is the effective length, and r is the least radius of gyration. These stresses shall be further reduced by an appropriate factor depending upon the permissible stresses as adopted from Annex B, since the stresses in IS 800 are based on permissible stresses of 0.66 YP. For bending stresses, the stresses specified in Annex B shall apply.

6.8.5 The arms if inclined may be fixed to the horizontal girders at about one-fifth of the width of the gate span from each end of the girder consistent with the design requirements.

6.8.6 The joints between the arms and the horizontal girders shall be designed against the side thrust due to the inclination of the arms, if inclined arms are used.

6.8.7 The arms shall be suitably braced by bracings in between the arms. The bracings connecting the arms that shall be so spaced, that the l/r ratio of the arms in both the longitudinal and transverse directions is nearly equal.

6.8.8 In case of gates likely to be overtopped, the end arms and other components should suitably be protected by means of side shields to prevent direct impact of water on arms. A hood may also be provided to protect the horizontal girders and other downstream parts.

6.9 Trunnion Hubs

6.9.1 The trunnion hubs shall rotate about the trunnion pins. The arms of the gate shall be rigidly connected to the hubs to ensure full transfer of loads.

6.9.2 The hubs shall be sufficiently long so as to allow the arms of the gate to be fixed to the respective limbs of the hubs, without having to cut and shape the flanges of the arms.

6.9.3 The thickness of the webs and flanges of each of the limbs of the hub shall be greater than that of arms to the extent possible so as to provide adequate space for the weld.

6.9.4 To ensure rigidity of the trunnion hub, sufficient number of ribs and stiffeners shall be provided in between its webs and flanges.

6.9.5 Minimum thickness of steel hub to be provided may be calculated from the following relationship. However, in the case of large size gates the hub may be designed as thick cylinder.

- i) for shaft up to 450 mm diameter $t = 0.3 d$
- ii) for shafts above 450 mm diameter $t = 0.25 d$ (not less than 135 mm)

Where, t = hub thickness; and
 d = diameter of the pin.

6.10 Trunnion Pins

6.10.1 The trunnion pin shall normally be supported at both ends on the trunnion bracket which is fixed to the anchorage or support girder. Where convenient the trunnion pins may be cantilever from the anchorage box, embedded in the piers or abutments.

6.10.2 The trunnion pin may be solid or hollow and shall be designed against bending for the total load transferred through the trunnion hub. The load shall be taken to be uniformly distributed over the length of the pin bearing against the hub.

6.10.2.1 The trunnion pin shall also be checked against shear and bearing due to the same load.

6.10.3 The bending, bearing and shear stress in the trunnion pin shall not exceed 0.33 YP, 0.35 UTS and 0.25 YP respectively.

6.10.4 Provision shall be made for a grease hole on the outer surface of the trunnion so as to allow the trunnion bearing and connected grooves to be greased periodically.

6.10.5 The trunnion pin shall be medium fit in the bearing lugs of the support and shall be suitably locked against rotation.

6.10.6 The trunnion pin should be subjected to ultrasonic/radiographic tests to ensure soundness against manufacturing defects.

6.10.7 Trunnion pins should be hard chromium plated to a minimum thickness of 50 microns if the same is not made of corrosion resistant steel.

6.11 Trunnion Bush/Bearing

6.11.1 Depending upon the requirements of design and factors like accessibility after erection design, load, size, cost effectiveness, simplicity, dependability and other considerations any of the following may be used.

- a) Slide type bronze bushing or self-lubricating bush bearings,

- b) Antifriction roller bearings, and
- c) Other special type of bearings like spherical plain bearings

6.11.2 The fits and tolerances to be adopted between the bushings/bearings, pin and trunnion hub shall be as follows [see IS 919 (Parts 1) and IS 919 (Part 2)].

<i>Type of Bearing</i> (1)	<i>Type of Fit</i> (2)	<i>Machine Tolerance</i> (3)
1) Bronze bushing a) with hub b) with pin	Interference fit Clearance fit	H7r6 H7f7
2) Antifriction bearing a) hub b) Pin	Interference fit Interference fit	H7 r6
3) Spherical plain bearing a) hub b) pin	Interference fit Interference fit	H7 r6 or p6

6.11.3 Minimum thickness of the bronze bushing (t_B) to be provided can be determined by the following formula. However, thickness of bushing shall not be less than 12 mm. Other bearings may be selected as per manufacturers rating catalogues.

$$t_B = 0.08 d + 3, \text{ where, } d \text{ is the pin diameter in mm.}$$

6.12 Trunnion Bracket

6.12.1 The bracket shall be rigidly fixed to the anchorage or support yoke girder by bolts or welding, it shall transfer the total load from the trunnion to the anchorage.

6.12.2 The bearing stress shall not exceed the value specified in Annex B.

6.12.3 The arms of the bracket shall also be designed to any bending, which may come on them due to the component of the load parallel to the base of the trunnion bracket.

6.12.4 Ribs and stiffeners shall be provided on the trunnion bracket, particularly on the sides of the bracket arms to ensure sufficient structural rigidity.

6.13 Anchorage System

6.13.1 The anchorage system shall be designed to withstand the total water load on the gate and transfer it to the piers and the abutments or to the civil structure within the tunnel or the conduit.

Alternatively, the trunnions may be located on an *in-situ* cast concrete beam/mass concrete in between the piers or concrete cantilever brackets transferring the loads directly in bearing.

6.13.2 The load may be transferred to the civil structure either in bond as a bond stress between the anchors and the concrete (see Fig. 1) or in bearing as a bearing stress between the concrete and the embedded girder at the upstream end of the anchors, which in this case are insulated from the concrete (see Fig. 2) or through a pre-stressed anchorage system using either steel rounds or steel cables.

6.13.3 Where the load is transferred by bond stress, rods are generally used as load carrying anchors. For insulated load carrying anchors, any convenient structural shape may be used although flats placed vertically or rods are generally preferred depending on the quantum of load. In the case of prestressed anchorages these can be either rods or cable.

6.13.4 For determining the force to be borne by the load-carrying anchors, the following procedure as given may be adopted.

6.13.4.1 The following procedure may be adopted to determine the forces:

- a) The maximum horizontal and vertical forces on the trunnion pin shall be determined. For the following conditions:
 - 1) Gate resting on sill and head on the gate varying from zero to maximum;
 - 2) Water level constant at the maximum level for which the gate has to be designed and the gate position varying from fully closed to fully open position. The worst combination of horizontal and vertical forces shall then be chosen; and
 - 3) For combined anchorage the loading shall also be determined with one gate closed and adjacent gate fully opened.
- b) If anchors used are inclined to the horizontal by an angle m the horizontal force so determined shall be multiplied by $\sec(m)$.
- c) For anchorages, where the anchors are not in a vertical plane through the trunnions but are in a vertical plane at a distance from the trunnions as in Fig. 1, the force F in the anchors shall be:

$$F = \frac{Py}{x}$$

where

P = the force determined in **6.13.4** and

x and y = the distance of the centre of gravity of the area in compression in concrete from the centre line of the load carrying anchors and the centre line of the trunnion respectively (see Fig. 1).

- d) For anchorages where the anchors are in a plane passing through the centre line of the trunnion and the thrust is transferred from the trunnions to these anchors through the yoke girder (see Fig. 2) the force in the anchors (p) shall be determined as per **6.13.4.1** (b).

6.13.5 The total stress in the anchors shall be the sum of the direct stress and the stress caused by the turning moment of the vertical force determined in **6.13.4.1** (a) wherever applicable.

6.13.6 The stresses in anchors made of structural steel shall not exceed the values as specified in Annex B.

6.13.7 If the load-carrying anchors are not welded to the trunnion girder but are fixed by nuts and locknuts, the ends of the anchors where considered economical may be forged to a larger diameter to provide at least the clear cross-sectional area of the anchors, at the root of the threaded portion.

6.13.8 The length of embedment of anchors for bonded type anchorages shall be such that the bond stress shall not exceed the permissible values for the concrete used subject to a minimum of two-thirds of radius of gate leaf. Anchors may be hooked at the end, or alternatively provided with anchor plates. Dimensions of the hook shall conform to those specified in **3.2** of IS 2502.

6.13.8.1 In case of bonded anchors to avoid cracking of face concrete, they should be insulated to a minimum of 500 mm length from the concrete face.

6.13.8.2 The length excluding anchor girder of insulated anchors which have an upstream embedded girder and where the load is transferred in bearing shall be such as to limit the shear stress in the 45° planes at the embedded girder to a safe permissible value subject to a minimum of 0.6 of the radius of gate.

6.13.9 All the load-carrying anchors whether bonded or insulated shall be suitably pretensioned on the trunnions to ensure proportionate load sharing by the anchor rods. In case of these anchors the prestresses shall be of a magnitude to introduce a stress of 5 percent of the permissible tensile stress in anchors.

6.14 Trunnion Girder or Yoke Girder

6.14.1 The trunnion girder may or may not be embedded in concrete. However, if embedded in concrete in the case of unloaded anchorage it shall also be wrapped in cork mastic or thermocol or other such material to provide space for displacement due to the

loading. It shall support the trunnion bracket and be held in place by the load-carrying anchors (see Fig. 1 and 2).

6.14.2 The girder shall be designed so as to be safe in bending, shear, and torsion if any, caused by the forces calculated in **6.13.4.1** (a).

6.14.3 The maximum shear stresses shall be calculated from the following considerations:

- a) Horizontal and vertical forces respectively determined in **6.13.4.1**, and
- b) Torque at the centre line of the trunnion girder due to the vertical force at the trunnion for case stated under **6.13.4.1** (a).

6.14.3.1 The total shear shall be the sum of values determined in **6.14.3** (a) and (b).

6.14.4 The maximum bending stress shall be calculated owing to the bending moment caused by the horizontal and vertical forces respectively.

6.14.5 The total shear stress calculated in **6.14.3** shall be combined to the bending stress calculated in **6.14.4** in accordance with IS 800.

6.14.6 The total combined stress in the trunnion girder for either the web or the flange shall not exceed values as specified in Annex B.

6.14.7 The maximum vertical force calculated in **6.13.4.1** shall be distributed by the trunnion girder to the concrete below the girder.

6.14.8 The total compressive stress in the concrete shall be determined by combining the direct compressive stress with the compressive or tensile stress caused due to the eccentricity of the vertical force.

6.14.8.1 The concrete immediately in contact with the trunnion girder which takes the thrust in bearing from it should be of non-shrinkage quality for a minimum thickness of 300 mm.

6.14.9 The maximum compressive stress in bearing at any point in the concrete in contact with anchor plate/girder shall not exceed $0.25 f_{ck}$ where (f_{ck} is the characteristic strength of the concrete used.)

6.14.10 Where the horizontal force from the trunnion pin is directly transferred to a yoke or trunnion girder immediately behind the trunnion pin (see Fig. 2) the yoke or anchorage girder shall be designed against bending and shear caused by this force.

6.14.11 The girder shall simply be treated as a supported beam loaded at the centre and supported at the junction of the girder and the load carrying anchors.

6.14.12 The bending and shear stress in the girder shall not exceed the values as specified in Annex B.

6.14.13 To allow for the elongation of the insulated load-carrying anchors and trunnion tie if used, the trunnion bracket shall be so fixed as to be able to slide on the rest chair.

Bronze or stainless steel pads shall be used for this purpose both on the top of the rest chair and at the bottom of the trunnion bracket (see Fig. 5).

6.14.14 The bearing stress on the bronze or stainless steel pad shall not exceed 0.3 YP.

6.14.15 Invariably all welded girders should be stress relieved unless the maximum thickness of plate used is less than 36 mm.

6.15 Thrust Block and Trunnion Tie

6.15.1 The thrust block or trunnion tie is required only if inclined arm; are used with the gate for resisting the horizontal forces. Alternatively, this lateral thrust can be directly transferred to the concrete pier through bearing from a plate embedded in concrete.

6.15.2 The thrust block shall be used when the horizontal force from the trunnion is directly transferred to a yoke girder immediately behind the trunnion (see **6.14.10**).

6.15.3 The thrust block is fixed to the trunnion/yoke girder and is designed to withstand the bending and shear force caused by the side thrust on the trunnion due to the inclined arms. A thrust washer should be used between the trunnion hub and trunnion bracket to transfer the thrust.

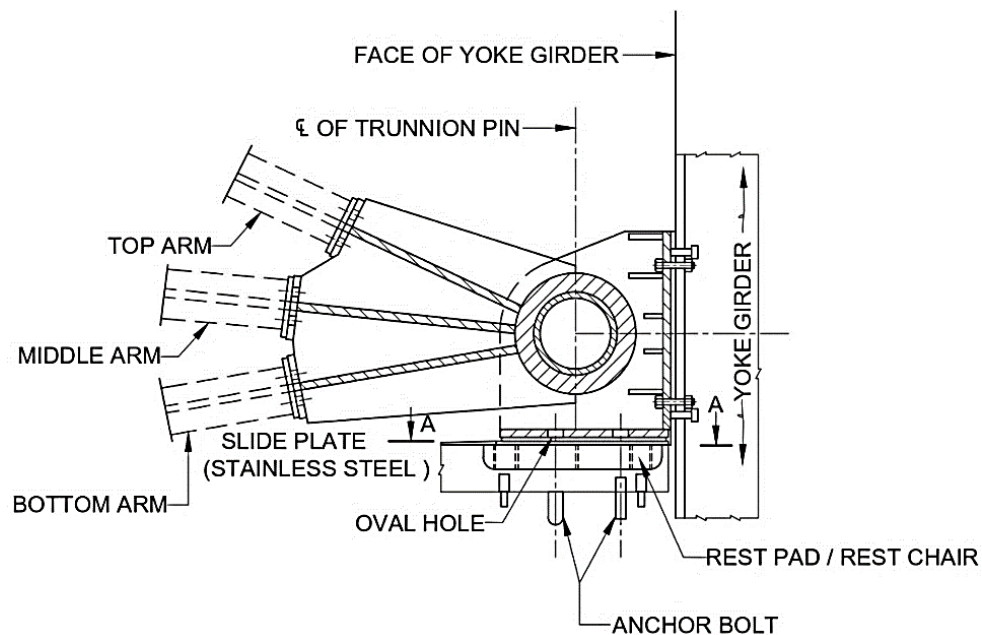

(A) CROSS SECTION

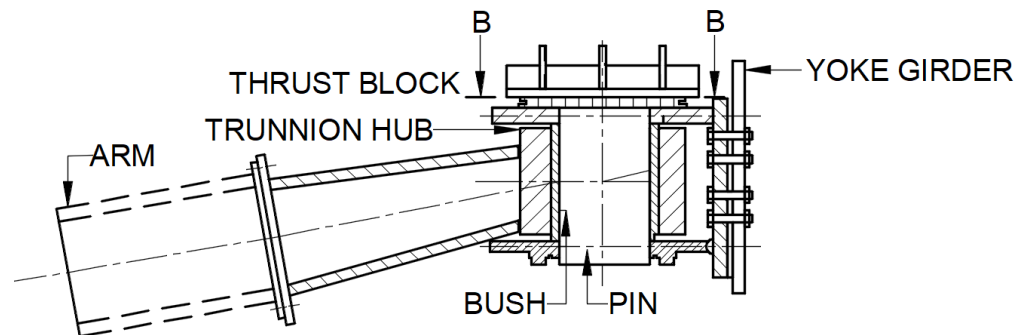

SECTIONAL PLAN OF TRUNNION ASSEMBLY

(B) SECTIONAL PLAN

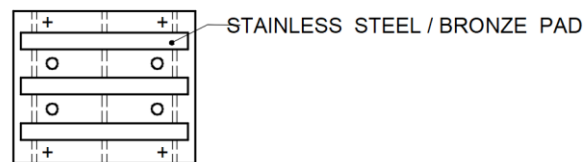

SECTION 'A-A' / 'B-B'

FIG. 5 TRUNNION ASSEMBLY ARRANGEMENT

6.15.4 The effect of the thrust block shall also be considered while computing the total compressive stress as given in **6.14.8**.

6.15.5 To allow for the elongation of the insulated load-carrying anchors, bronze to bronze sliding surfaces or bronze to stainless steel sliding surfaces shall be provided on the face of the thrust block and the mating face of the trunnion bracket (see Fig. 5).

6.15.6 The bearing stress on the bronze or stainless steel pads shall not exceed 0.3 YP.

6.15.7 Alternatively the trunnion tie can be used to withstand the side thrust caused by use of inclined arms.

6.15.8 The tensile stress in the tie beam shall not exceed the values specified in Annex B.

6.15.9 The trunnion tie shall span from one trunnion hub to the other and shall be fixed securely to the trunnion hub either by welding or by long bolts passing through holes in the trunnion hub.

6.15.10 For the trunnion tie beam standard rolled/ fabricated section or a steel pipe with flanges at the ends for bolting may be used.

6.15.11 The deflection of the trunnion tie beam due to self-weight shall be in accordance with IS 800.

6.16 Seals

6.16.1 The seals shall be fixed so as to bear tightly on the seal seats to prevent leakage in the fully closed position of the gate (see Fig. 1 and 2). For reducing seal friction, clad seals may be used. The cladding may be of brass, bronze, stainless steel, fluorocarbon to ensure a watertight mating of the gate leaf with the embedded frame.

6.16.2 Various types of seals generally used for different classes of gates shall be in accordance with IS 11855.

6.16.3 Seal Interference

6.16.3.1 The seal interference shall vary from 2 mm to 5 mm depending upon the requirement and type of installation shape of seal being used and other relevant criteria. Generally high head and larger size gates require more seal interference compared to low head and small gates. Suitable chamfer shall be provided at the bottom of the skin plate as well as the seal clamp plate to accommodate the bottom wedge seal in compressed position.

6.16.3.2 The permissible deflection of gates, with top sealing at the top sealing point should be 80 percent of initial compression of seal.

6.17 Seal Seat, Seal Seat Base and Sill Beam

6.17.1 Minimum thickness of stainless steel seal seat plate shall be 6 mm for low head gates and 8 mm in other cases after machining.

6.17.2 The seal-seat shall be either welded or screwed to the seal base. If screwed, the head of the screws shall lie at least 1 mm below the surface of the seal seat. The number of screws should be such as to give sufficient rigidity to the assembly. The screws shall be of corrosion resisting steel/brass.

6.17.3 The seal-seat shall be finished smooth.

6.17.4 The seal-seat base on which the seal-seat is fixed shall be made up of plate or any structural section. Angles or flats are used to fix the seal-seat base to the embedded anchor bolts. After complete installation the side seals wall plates and the bottom seal-seat shall preferably be flush with the surrounding concrete surfaces.

6.17.5 For conduit gates, the upstream face of the gate provides the seal-seat for the seals fixed to the embedded metal (see Fig. 3). The provision of **6.17.1** to **6.17.3** shall apply to the bottom seal.

6.17.6 The sill beam shall be provided with stainless steel flats welded or screwed on the top surface with stainless steel screws. The minimum thickness of stainless steel flat shall be 6 mm after machining. The surface of the sill beam shall be machined smooth and made flush with the surrounding concrete.

6.18 Guide Roller

6.18.1 Guide rollers shall be provided on the sides of the gate to limit the lateral motion or side sway of the gate to not more than 6 mm in either direction. At least two guide rollers on each side shall remain within the wall plate area when the gate is in fully raised condition.

6.18.1.1 The rollers shall be adjustable and removable. They shall travel on wall plates but the portion of the wall plates on which they travel may be made of structural steel instead of stainless steel.

6.18.1.2 The rollers shall be provided with plain bronze bushings turning on fixed steel pins. Provision for greasing the bushings shall also be made. Guide roller pin should be hard chrome plated to minimum 20 microns if material used is structural steel. Tolerances for guide roller assembly should be as given in **6.11.2**.

6.18.2 The guide rollers for gates shall be designed for a force equivalent to 5 percent of gate weight shared by all rollers on either side equally.

6.18.3 Permissible stresses in design shall be same as given in Annex B.

6.19 Anchor Bolts or Anchor Plates

6.19.1 In order to ensure proper alignment of the embedded parts, anchorages shall invariably be provided in two stages, that is, partly in the first stage concrete with suitable blockout openings to hold the balance embedded parts in the second stage concrete. For effective bonding of first stage and second stage concrete, suitable dowel bars should be provided and interface surface should be kept thoroughly rough. The anchor bolts in second stage concrete shall be provided with double nuts and washers. For adjustment purposes enlarged holes in the second stage embedded parts plates/ joist sections, webs and flanges shall be provided. Preferably anchor plates may be embedded in first stage concrete and anchor bolts welded subsequently.

6.19.2 The anchor bolts should not be less than 16 mm diameter. Washers shall invariably be used with the anchor bolts.

6.20 Tolerances

6.20.1 The tolerances for embedded parts and components of gates are given in Annex E. The distance between the wall plates shall be true within a tolerance of 3 mm. The anchors shall be set in the blockouts within a tolerance of 3 mm.

6.20.2 The trunnions shall be coaxial, at the same elevation, and perpendicular to centre line of gate opening.

6.21 Non-destructive Testing of Welds

All butt welds in gate components shall be 100 percent radiographically tested for their soundness. However, extent of radiography for joints in the skin plate alone could be limited to 10 percent of total weld length suitably selected. However other tests like ultrasonic dye penetrant or magnetic particle test could be conducted for full length of butt joints in the skin plate. All butt joints in hoist bridge shall also be tested radiographically 100 percent for their soundness.

7 OCCASIONAL FORCES

7.1 Earthquake Effect

Earthquake forces shall be computed in accordance with IS 1893 and the gate designed accordingly.

7.2 Wave Effect

For very wide and big reservoirs, the effect of wave height due to storms, etc, in causing increased loading on the gate, shall also be considered.

7.3 Occasional Overtopping

Whenever occasional overtopping of gate is allowed the design of gate shall be checked for increased stresses.

7.4 Permissible Stresses

The stresses in the various parts of the gate under the action of occasional forces shall not exceed 133 percent of the permissible stresses specified in Annex B subject to the maximum of 85 percent of the yield stress. In case of nuts and bolts, increase in stress shall not be more than 25 percent of allowable stress.

7.5 The earthquake forces, the wave effect and occasional overtopping shall not be considered to act simultaneously while computing the increased stress in the gate.

8 ICE LOAD

8.1 Ice impact and ice pressure Provided local conditions do not impose other values, ice impact and ice pressure shall be considered in such a way that the water pressure triangle shall be replaced as given below:

- a) In waters with ice thickness equal to or greater than 300 mm, by an even surface pressure of 30 000 N/m² up to 3 m depth; and.
- b) In waters with ice thickness up to 300 mm by an even surface pressure of 20 000 N/m² up to 2 m depth.

9 Silt Load

Silt load, if applicable, may be considered for design of gate components and anchorages. Accordingly, silt load may also be considered to calculate hoist capacity.

ANNEX A
(Clause 2)**LIST OF REFERRED INDIAN STANDARDS**

<i>IS No.</i>	<i>Title</i>
IS 210 : 2009	Grey iron castings — Specification (<i>first revision</i>)
IS 305 : 1981	Specification for aluminum bronze ingots and castings (<i>second revision</i>)
IS 306 : 1983	Specification for tin bronze ingots and castings (<i>third revision</i>)
IS 318 : 1981	Specification for leaded tin bronze ingots and castings (<i>second revision</i>)
IS 456 : 2000	Plain and reinforced concrete (<i>fourth revision</i>)
IS 800 : 2007	Code of practice for general construction in steel (<i>third revision</i>)
IS 919 (Part 1) : 2014	Geometrical product specifications (GPS) - ISO code system for tolerances on linear sizes Part 1 Basis of tolerance, deviation and fits (<i>third revision</i>)
919 (Part 2) : 2014	Tables of standard tolerance classes and limit deviation for holes and shafts (<i>second revision</i>)
1030 : 1998	Carbon steel castings for general engineering purposes (<i>fifth revision</i>)
1068 : 1993	Electroplated coatings of nickel plus chromium and copper plus nickel plus chromium (<i>third revision</i>)
1893 : 1984	Criteria for earthquake resistant design of structures (<i>fourth revision</i>)
2004 : 1991	Carbon steel forgings for general engineering purposes — Specification (<i>third revision</i>)
2062 : 2011	Hot rolled medium and high tensile structural steel - Specification (<i>seventh revision</i>)

2502 : 1963	Code of practice for bending and fixing of bars for concrete reinforcement
3444 : 1999	Corrosion resistant high alloy steel and nickel base castings for general applications - Specification (<i>third revision</i>)
6603 : 2001	Stainless steel bars and flats — Specification (<i>first revision</i>)
6911 : 2017	Stainless steel plate, sheet and strip (<i>second revision</i>)
10021 : 2000	Guidelines for de-icing system for hydraulic installations (<i>first revision</i>)
11855 : 2017	Design and use of rubber seals for hydraulic gates — Recommendations (<i>second revision</i>)

ANNEX B

(Clauses 6.6.7, 6.6.8, 6.7.5, 6.8.4, 6.12.2, 6.13.6, 6.14.6, 6.14.12, 6.15.8, 6.18.3 and 7.4)

PERMISSIBLE MONOAXIAL STRESSES FOR STRUCTURAL COMPONENTS OF HYDRAULIC GATES

Sl No.	Material and Types of of Stress		Wet Condition		Dry Condition	
			Accessible	Inaccessible	Accessible	Inaccessible
(1)	(2)		(3)	(4)	(5)	(6)
i)	Steel:					
	a)	Direct compression and compression in bending	0.45 YP	0.40 YP	0.55 YP	0.45 YP
	b)	Direct tension and tension in bending	0.45 YP	0.40 YP	0.55 YP	0.45 YP
	c)	Shear Stress	0.35 YP	0.30 YP	0.40 YP	0.35 YP
	d)	Combined stress	0.60 YP	0.50 YP	0.75 YP	0.60 YP
	e)	Bearing stress	0.65 YP	0.45 YP	0.75 YP	0.65 YP
ii)	Bronze or Brass					
		Bearing Stress	0.035 UTS	0.030 UTS	0.040 UTS	0.035 UTS

NOTE

1 YP stands for minimum guaranteed yield point stress, UTS stands for ultimate tensile strength. For materials which have no definite yield point. The yield point may be taken at 0.2 percent proof stress.

2 The term 'wet condition' applies to skin plates and those components of gate which may have a sustained contact with water, for example, horizontal girder and other components located on upstream side of skin plate. The term 'dry condition' applies to all components which generally do not have a sustained contact with water, for example, girders, stiffeners, etc. on downstream side of skin plate, even though there may be likelihood of their wetting due to occasional spray of water.

3 The term accessible applies to gates which are kept in easily accessible locations and can, therefore, be frequently inspected and maintained, for example, gates and stoplogs which are stored above water level and are lowered only during operations. The term inaccessible applies to gates which are kept below water level and/or are not easily available for frequent inspection and maintenance, for example, gates kept below water level or in the bonnet space even while in the raised position or gates which on account of their frequent use are generally in water.

ANNEX C
 [Clause 6.6.2 (b), 6.6.4]

METHOD OF COMPUTATION OF BENDING STRESS IN FLAT PLATES

C 1 STRESS OF FLAT PLATES IN PANELS

C 1.1 Bending stresses in flat plate may be computed from the following formula:

$$\sigma = \frac{K}{100} \times \frac{p \times a^2}{s^2}$$

Where,

- σ = bending stress in flat plate in N/mm²,
- K = non-dimensional factor depending on values of a and h ,
- p = water pressure in N/mm² (relative to the plate centre),
- a, b = panel width in mm (see Fig. 6 to 11), and
- s = plate thickness in mm.

The K values for points and support conditions given in Fig. 6 to 11 are given in Tables 2, 3 and 4.

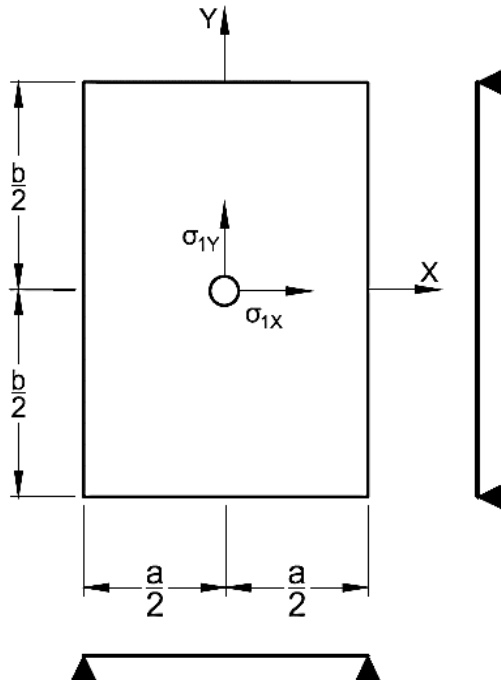

FIG. 6 ALL EDGES SIMPLY SUPPORTED

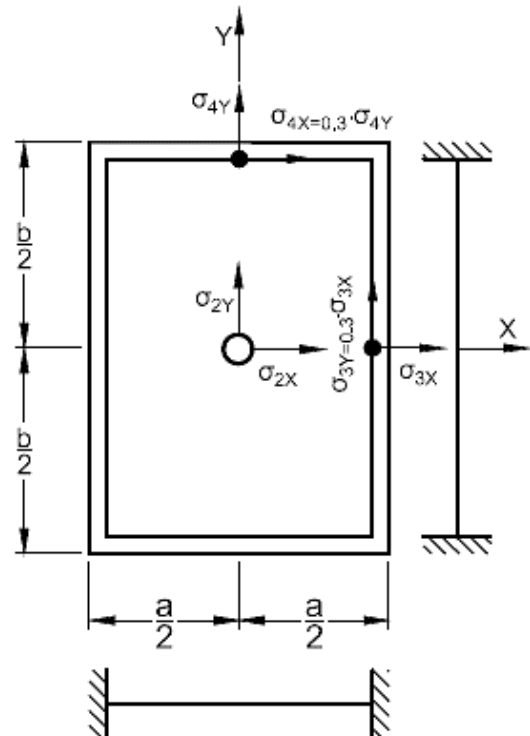

FIG.7 ALL EDGE RIGIDLY FIXED

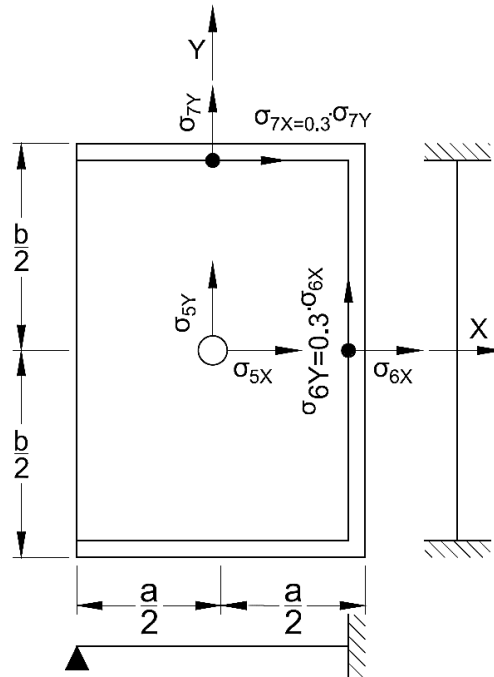

FIG. 8 TWO SHORT AND ONE LONG EDGES FIXED AND ONE LONG EDGE SIMPLY SUPPORTED

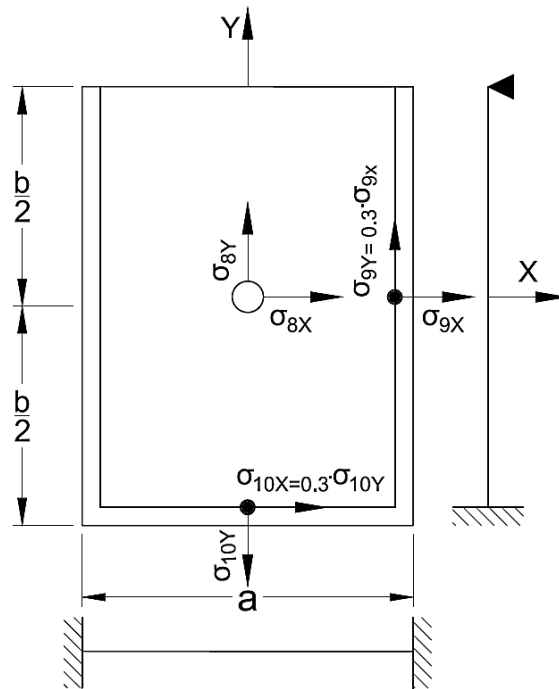

FIG. 9 TWO LONG AND ONE SHORT EDGE FIXED AND ONE SHORT EDGE SIMPLY SUPPORTED

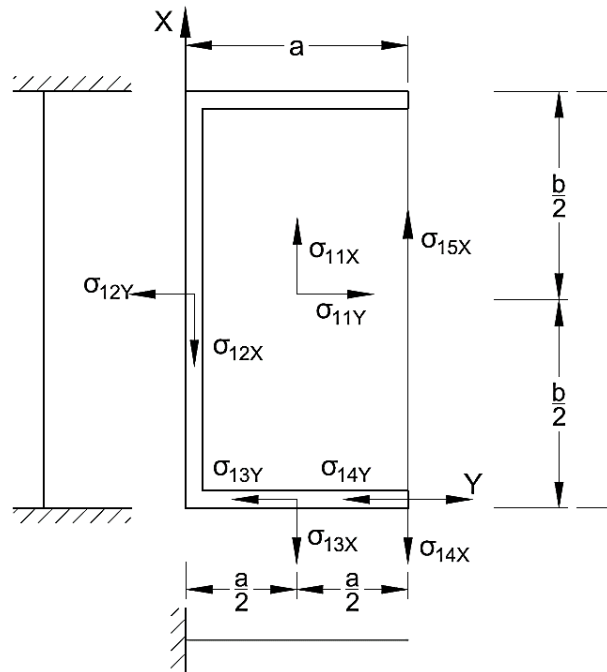

FIG. 10 THREE EDGES FIXED AND ONE LONG EDGE FREE

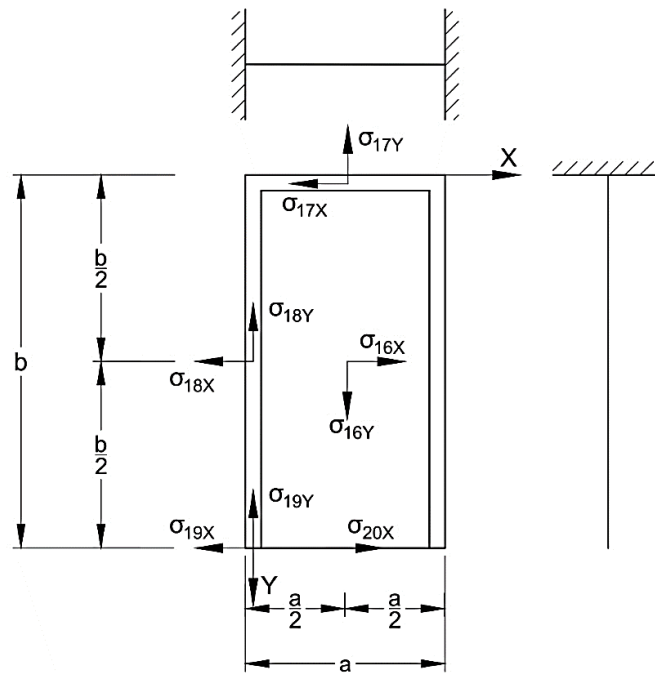

FIG. 11 THREE EDGES FIXED AND ONE (SHORTER) EDGE FREE

Table 2 Values of K for Points and Support Conditions given in Fig. 6 to Fig. 9
(Clause C 1.1)

SI No.	b/a	$\pm\sigma_{1x}$	$\pm\sigma_{1y}$	$\pm\sigma_{2x}$	$\pm\sigma_{2y}$	$\pm\sigma_{4y}$	$\pm\sigma_{3x}$	$\pm\sigma_{5x}$	$\pm\sigma_{5y}$	$\pm\sigma_{7y}$	$\pm\sigma_{6x}$	$\pm\sigma_{8x}$	$\pm\sigma_{8y}$	$\pm\sigma_{10y}$	$\pm\sigma_{9x}$
(1)	(2)	(3)	(4)	(5)	(6)	(7)	(8)	(9)	(10)	(11)	(12)	(13)	(14)	(15)	
i)	α	75.0	22.5	25.0	7.5	34.2	50.0	37.5	11.3	47.2	75.0	25.0	7.5	34.2	50.0
ii)	3	71.3	24.4	25.0	7.5	34.3	50.0	37.4	12.0	47.1	74.0	25.0	7.6	34.2	50.0
iii)	2.5	67.7	25.8	25.0	8.0	34.3	50.0	36.6	13.3	47.0	73.2	25.0	8.0	34.2	50.0
iv)	2	61.0	27.8	24.7	9.5	34.3	49.9	33.8	15.5	47.0	68.3	25.0	9.0	34.2	50.0
v)	1.75	55.8	28.9	23.9	10.8	34.3	48.4	30.8	16.5	46.5	63.2	24.6	10.1	34.1	48.9
vi)	1.5	48.7	29.9	22.1	12.2	34.3	45.5	27.1	18.1	45.5	56.5	23.2	11.4	34.1	47.3
vii)	1.25	39.6	30.1	18.8	13.5	33.9	40.3	21.4	18.4	42.5	47.2	20.8	12.9	34.1	44.8
viii)	1	28.7	28.7	13.7	13.7	30.9	30.9	14.2	16.6	36.0	32.8	16.6	14.2	32.8	36.0
Note — The edges over which the panels are continuous may, for all practical purposes, be treated as edges rigidly fixed. However, more exact analysis may be resorted to at the discretion of the designer.															

Table 3 Values of K for Points and Support Conditions given in Fig. 10
(Clause C 1.1)

SI No.	b/a	$\pm\sigma_{11x}$	$\pm\sigma_{11y}$	$\pm\sigma_{12x}$	$\pm\sigma_{12y}$	$\pm\sigma_{13x}$	$\pm\sigma_{13y}$	$\pm\sigma_{14x}$	$\pm\sigma_{14y}$	$\pm\sigma_{15x}$	$\pm\sigma_{15y}$
(1)	(2)	(3)	(4)	(5)	(6)	(7)	(8)	(9)	(10)	(11)	(12)
i)	α	22.00	75.00	90.00	300.00	91.00	28.00	205.00	62.00	2.00	0
ii)	1.0	17.67	12.29	9.45	31.50	37.64	11.29	44.55	13.40	27.96	0
iii)	1.25	22.50	13.00	15.50	51.50	48.00	14.80	53.00	16.20	37.00	0
iv)	1.50	23.50	14.20	20.50	72.50	59.50	18.20	82.00	22.70	48.00	0
v)	1.75	23.00	14.00	25.80	87.00	67.50	20.80	112.00	34.80	61.00	0
vi)	2.0	19.49	6.72	33.98	113.28	72.96	21.89	134.40	40.32	69.88	0
vii)	2.5	18.37	2.88	42.05	140.16	51.84	15.55	124.80	37.44	52.42	0
viii)	3.0	19.78	7.68	44.93	149.76	65.28	19.59	109.44	32.84	52.41	0

Table 4 Values of K for Points and support conditions given in Fig. 11
(Clause C1.1)

SI No.	b/a	$\pm\sigma_{16x}$	$\pm\sigma_{16y}$	$\pm\sigma_{17x}$	$\pm\sigma_{17y}$	$\pm\sigma_{18x}$	$\pm\sigma_{18y}$	$\pm\sigma_{19x}$	$\pm\sigma_{19y}$	$\pm\sigma_{20x}$	$\pm\sigma_{20y}$
(1)	(2)	(3)	(4)	(5)	(6)	(7)	(8)	(9)	(10)	(11)	(12)
i)	α	29.00	9.00	9.00	30.00	50.00	15.00	51.00	16.00	29.00	0
ii)	1.0	17.67	12.29	9.45	31.50	37.64	11.29	44.55	13.40	27.96	0
iii)	1.25	20.80	11.70	8.96	29.87	28.00	8.40	34.50	10.35	28.53	0
iv)	1.50	25.51	11.12	8.48	28.28	21.04	6.31	25.53	7.66	29.11	0
v)	1.75	26.48	10.56	8.49	28.30	32.00	9.60	36.50	10.95	28.97	0
vi)	2.0	27.46	10.00	8.50	28.36	45.52	13.66	50.09	15.27	28.81	0
vii)	2.5	28.07	9.13	8.51	28.38	46.66	14.00	50.80	15.24	28.78	0
viii)	3.0	28.18	8.68	8.51	28.38	46.94	14.08	50.81	15.24	28.77	0

ANNEX D

[Clause 6.6.5 (b)]

METHOD OF CALCULATION OF COACTING WIDTH OF SKIN PLATE WITH GIRDER OR STIFFENERS

D-1 METHOD

D-1.1 Co acting width of skin plate is given by $2(V \times B)$.

where

V = reduction factor (non-dimensional) depends on the ratio of the support length to the span of the plate and on the action of the moments, and is ascertainable from Fig. 12 and 13; and

B = half the span of the plate between two girders (see Fig. 12) or overhang length of a bracket plate.

D 1.1.1 The ideal support length L_I or L_{II} (see Fig. 12) corresponding to the length of the moment zone of equal sign shall in the case of continuous girders be basic as support length L . In the case of single bay girders, the ideal support length corresponds to the actual.

V_I = reduction factor corresponding to the parabolic moment zone (see Fig. 12 and 13); and

V_{II} = reduction factor corresponding to the moment zone composed of two concave parabolic stresses and approximately the triangular shaped moment zone (shown with dashes in Fig. 12 and 13).

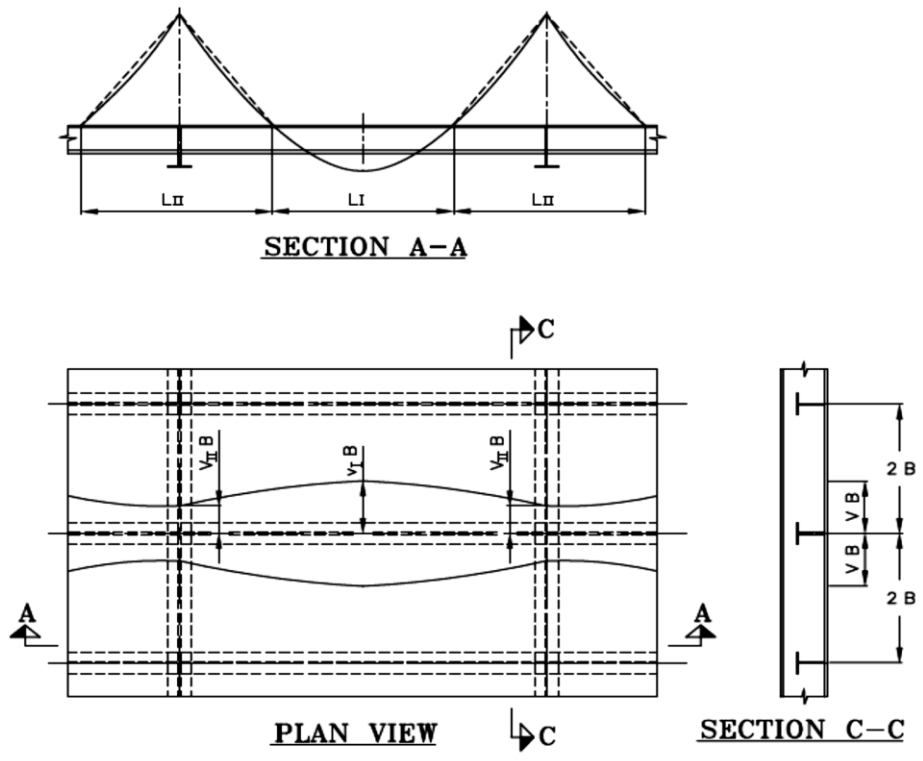

FIG.12 FIGURE SHOWING VARIATION OF CO-ACTING WIDTH FROM SUPPORT TO SUPPORT

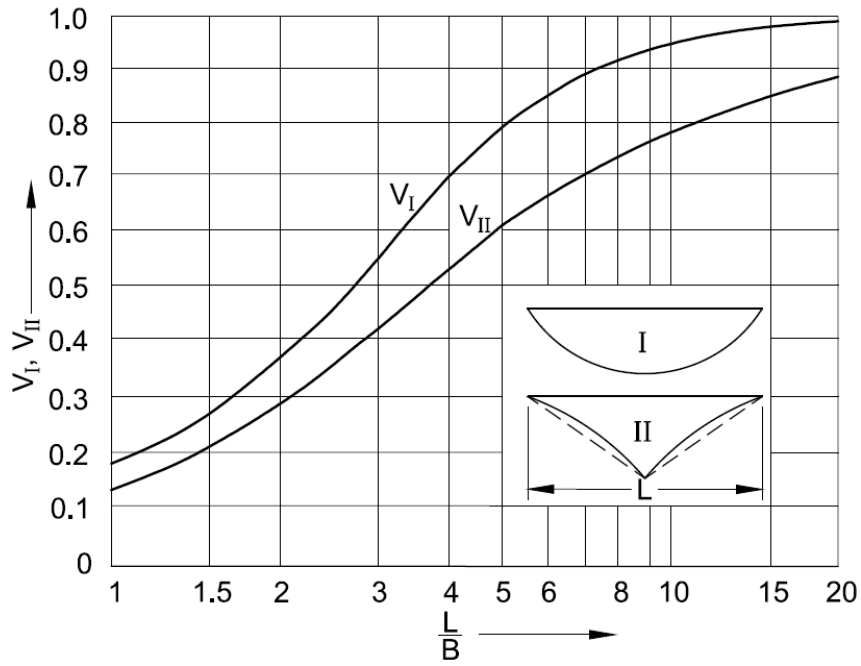

FIG. 13 CURVES SHOWING RELATIONSHIP BETWEEN L/B AND REDUCTION FACTORS V_I AND V_{II}

ANNEX E

(Clause 6.20.1)

TOLERANCES FOR EMBEDDED PARTS AND COMPONENTS OF GATES

<i>Components</i>	<i>Tolerances</i>
1) EMBEDDED PARTS	
a) Wall Plate and Sill Plate:	
1) Distance between centre line of opening and face of wall plate at sill end	+ 0.00 mm - 2.00 mm
2) Distance between centre line of opening and face of wall plate at top end	+ 2.00 mm - 0.00 mm
3) Straightness of face of wall plates and sill plates	Offset all joints to be ground smooth
4) Normality of face of wall plates to gate sill and centre line of trunnion bearings	+ 0.01° - 0.00°
5) Alignment of sill plate in horizontal plane	± 0.25
2) COMPONENTS OF GATES	
a) Guide Roller/Guide Shoe: Distance between centre line of gate and face of side seal	+ 1.00 mm - 2.00 mm
b) Side Seal : Distance between centre line of gate and face of side seal	± 1.0 mm
c) Trunnion Bearings :	
1) Collinearity of centre lines of both the trunnion bearings	± 0.25 mm
2) Horizontality of centre lines of both the trunnion bearings	± 0.25 mm
3) Parallel distance of centre line of both the trunnion bearings from upstream bottom edge of skin plate	± 3.00 mm

4) Tolerances in diameters of pin, bush hub and bracket of trunnion assembly	To suit diameters and required fits
--	-------------------------------------

