

**BUREAU OF INDIAN STANDARD**  
**DRAFT FOR COMMENTS ONLY**

*(Not to be reproduced without the permission of BIS or used as an Indian Standard)*

**भारतीय मानक मसौदा**

**क्षैतिज और प्रवण एप्रन के साथ द्रव-चालित जंप टाइप  
स्टिलिंग बेसिन के डिजाइन के लिए मानदंड**  
(IS 4997 का पहला पुनरीक्षण)

**Draft Indian Standard**

**CRITERIA FOR DESIGN OF HYDRAULIC JUMP TYPE STILLING  
BASINS WITH HORIZONTAL AND SLOPING APRON**  
(First Revision of IS 4997)

ICS 93.160

---

Dams and Spillways  
Sectional Committee, WRD 09

Last date for Comments:  
**18 November 2024**

---

**FOREWORD**

*(Formal clauses of the foreword will be added later)*

The design of downstream protection works or energy dissipators below hydraulic structures occupies a vital place in the design and construction of dams, weirs and barrages. The problem of designing energy dissipators is one essentially of reducing the high-velocity flow to a velocity low enough to minimize erosion of the natural river bed. This reduction in velocity can be accomplished by any or a combination of the following, depending upon the head, discharge intensity, tail-water conditions and the type of the bedrock or the bed material:

- a) Hydraulic jump type stilling basins:
  - 1) Horizontal apron type; and
  - 2) Sloping apron type.
  
- b) Jet diffusion and free jet stilling basins:
  - 1) Jet diffusion basins;
  - 2) Free jet stilling basins;
  - 3) Hump stilling basins; and
  - 4) Impact stilling basins.

- c) Bucket type dissipators:
  - 1) Solid and slotted roller buckets; and
  - 2) Trajectory buckets (ski-jump, flip etc.).
- d) Intersecting jets and other special type of stilling basins.

The major concern with the stilling basin type dissipator is more of structural strength rather than its hydraulic efficiency. Experiences had shown many examples of stilling basins suffering serious damages due to uplift, vibration, cavitation, and abrasion, all having their origin in the internal structure of hydraulic jump. The other relevant factors like determination of thickness of concrete floor of stilling basin, divide walls etc. have been covered in other standards pertaining to the structural designs of spillways

The design criteria recommended in this standard is meant for stilling basins of rectangular cross-section with horizontal and sloping apron. The criteria given in this standard would hold, provided that the jet entering the basin is reasonably uniform with regard to both velocity and depth. Though the criteria are applicable for all cases, yet for falls greater than 15 m, discharge intensities greater than 30 m<sup>3</sup>/s/m and possible asymmetry of flow, the specific design should be tested on model.

Stilling basins are the most common types of energy dissipators provided at the toe of spillways if tail water levels are favourable for formation of hydraulic jump.

This standard was first published in 1968. The first revision of this standard incorporates the latest generalized design trends in vogue, emphasizing the operational aspects of stilling basin. Following are the major changes incorporated in the first revision of this standard:

- a) Provision of divide walls;
- b) Necessity of cylindrical end sill;
- c) Bulking of flow and stilling basin free board;
- d) Calculation of head loss due to friction over the spillway surface;
- e) Informative list of projects with stilling basin as energy dissipator for existing and proposed dam spillways; and
- f) Graphs for ratio of tail water depth to  $D_1$  with respect to Froude number incorporated.

As the flow within hydraulic jump is an extremely complicated and rapidly varied flow, characterized by the development of large-scale turbulence, surface waves and spray, energy dissipation and air entrainment, it is recommended that the hydraulic design of stilling basin should be further optimized functionally and economically from the physical model studies

For the purpose of deciding whether a particular requirement of this standard is complied with, the final value, observed or calculated, expressing the result of a test or analysis,

shall be rounded off in accordance with IS 2 : 2022 'Rules for rounding off numerical values (*second revision*)'. The number of significant places retained in the rounded-off value should be the same as that of the specified value in this standard.

**Draft Indian Standard****CRITERIA FOR DESIGN OF HYDRAULIC JUMP TYPE STILLING  
BASINS WITH HORIZONTAL AND SLOPING APRON***(First Revision of IS 4997)*Dams and Spillways  
Sectional Committee, WRD 09Last date for Comments:  
**18 November 2024****1 SCOPE**

This standard lays down the criteria for the design of hydraulic jump type stilling basins of rectangular cross-section with horizontal and sloping apron utilizing various energy dissipators, for example, chute blocks, basin or floor blocks and end sill.

**2 NOTATIONS**

For the purpose of this standard, the following notations shall have the meaning indicated against each:

|        |   |  |
|--------|---|--|
| $D_1$  | = | depth of flow at the beginning of the jump, measured perpendicular to the floor                |
| $D_2$  | = | depth conjugate (sequent) to $D_1$ for horizontal apron  |
| $D'_2$ | = | depth conjugate (sequent) to $D_1$ for sloping apron (or partly sloping and partly horizontal) |
| $D_b$  | = | depth of basin   |
| $D_c$  | = | critical water depth   |
| $F_1$  | = | Froude number of the flow at the beginning of the jump   |
| $g$    | = | acceleration due to gravity  |
| $h_b$  | = | height of basin blocks   |
| $h_c$  | = | height of chute blocks   |
| $H_L$  | = | head loss in hydraulic jump  |
| $h_e$  | = | height of end sill   |
| $K$    | = | shape factor   |
| $l$    | = | length of the inclined portion in basin IV   |
| $L_b$  | = | length of the basin  |
| $L_j$  | = | length of hydraulic jump   |
| $q$    | = | discharge intensity  |
| $S_b$  | = | spacing of basin blocks  |
| $S_c$  | = | spacing of chute blocks  |
| $S_d$  | = | spacing of dents in dentated sill  |
| $V_1$  | = | velocity of flow at the beginning of the jump  |
| $V_2$  | = | velocity of flow at the end of jump  |
| $w_b$  | = | width of basin blocks  |

|          |   |  |
|----------|---|--|
| $W_c$    | = | width of chute blocks                          |
| $W_d$    | = | width of dents in dentated sill                |
| $\theta$ | = | angle of the sloping apron with the horizontal |

### 3 TERMINOLOGY

For the purpose of this standard, the following definitions shall apply (see Fig. 1 and Fig. 2).

**3.1 Hydraulic Jump** — Hydraulic jump in an open channel is a transition from the water depth  $D_1 < D_c$  to  $D_2 > D_c$ .

**3.2 Length of Hydraulic Jump** — The distance from the beginning of the jump to a point downstream where either the high velocity jet begins to leave the floor or to a point on the surface immediately downstream of the roller, whichever is the longer as shown in Fig. 1 and Fig. 2. The length of hydraulic jump can be determined from Fig. 3.

**3.3 Conjugate Depths** — Water depths at the beginning and the end of the hydraulic jump related by the formula:

$$\frac{D_2}{D_1} = \frac{1}{2} \left[ \sqrt{1 + 8 F_1^2} - 1 \right] \text{ ...for horizontal apron}$$

$$\frac{D_2'}{D_1} = \frac{1}{2 \cos \theta} \left[ \left( \frac{8 F_1^2 \cos^3 \theta}{1 - 2 K \tan \theta} + 1 \right)^{1/2} - 1 \right] \text{ ... for fully sloping apron}$$

where approximate value of  $K$  may be determined from Fig. 4. However,  $D_2'$  can also be determined from Fig. 5 and Fig. 12.

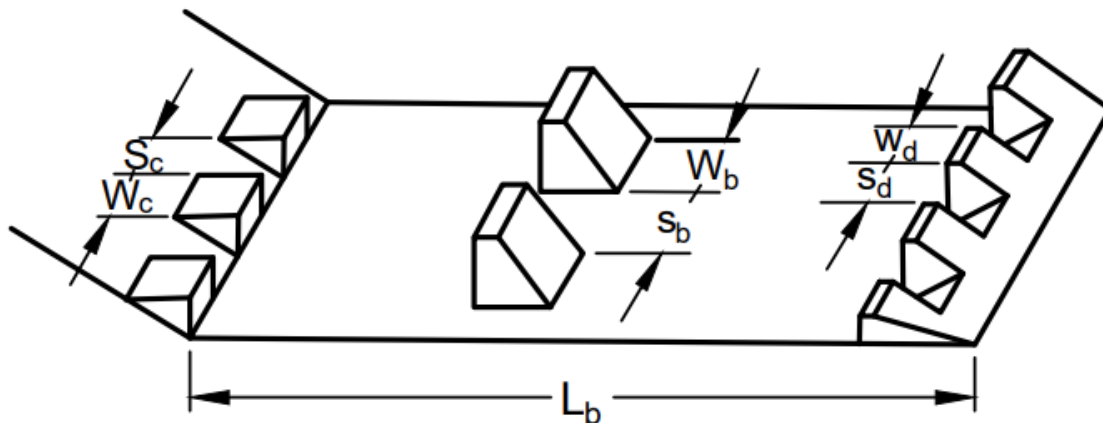

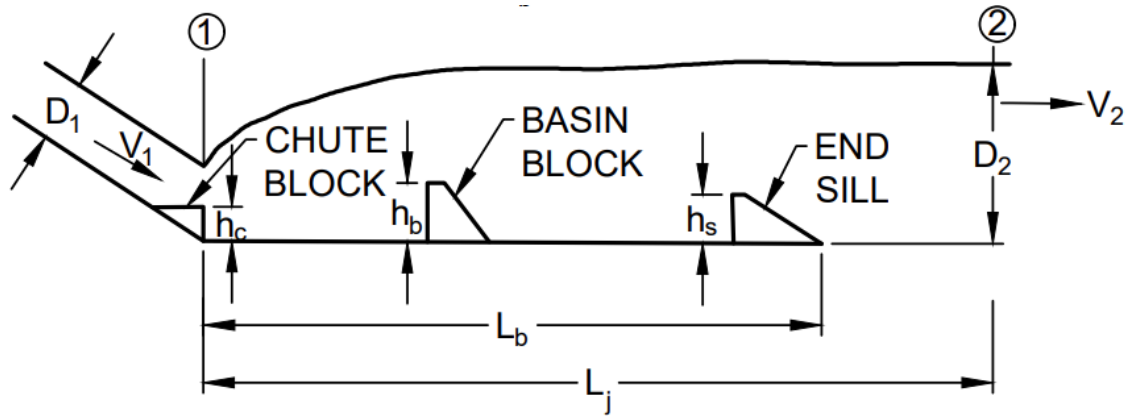
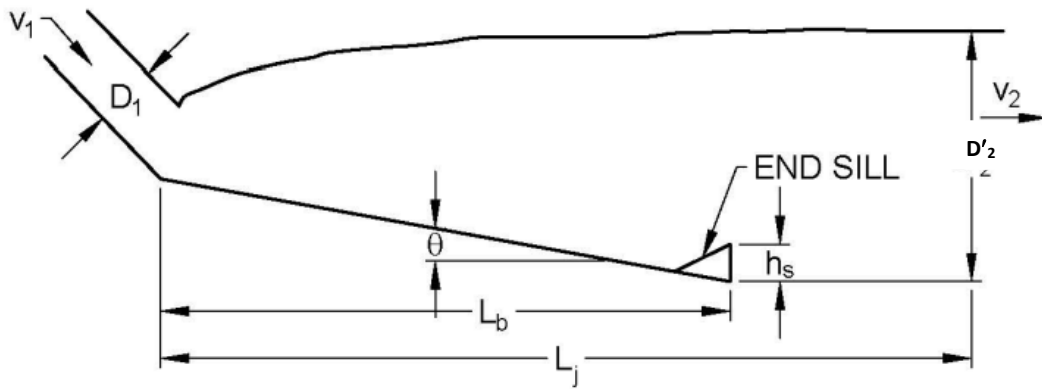
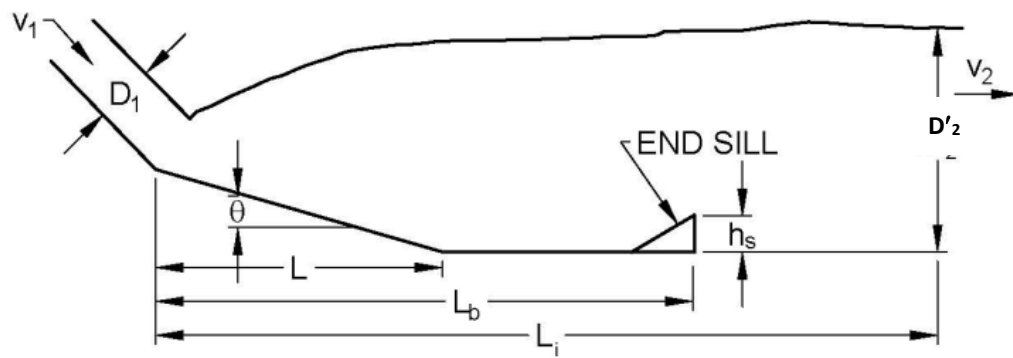

FIG.1 DEFINITION SKETCH BASIN I AND II



(A) DEFINITION SKETCH BASIN III



(B) DEFINITION SKETCH BASIN IV

FIG. 2 DEFINITION SKETCHES OF BASIN III AND IV

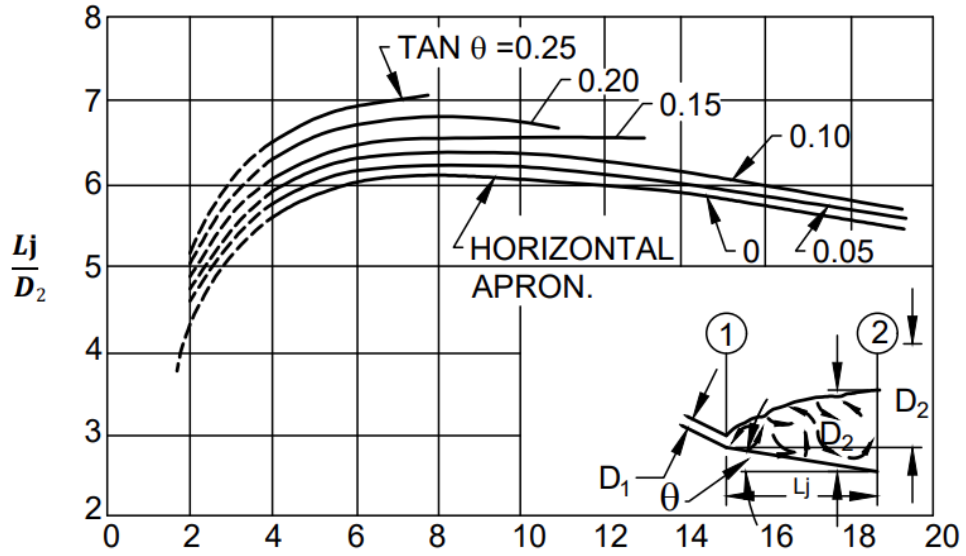

$$F_1 = \frac{v_1}{\sqrt{g D_1}}$$

FIG. 3 LENGTH OF JUMP OF CONJUGATE DEPTH  $D_2$

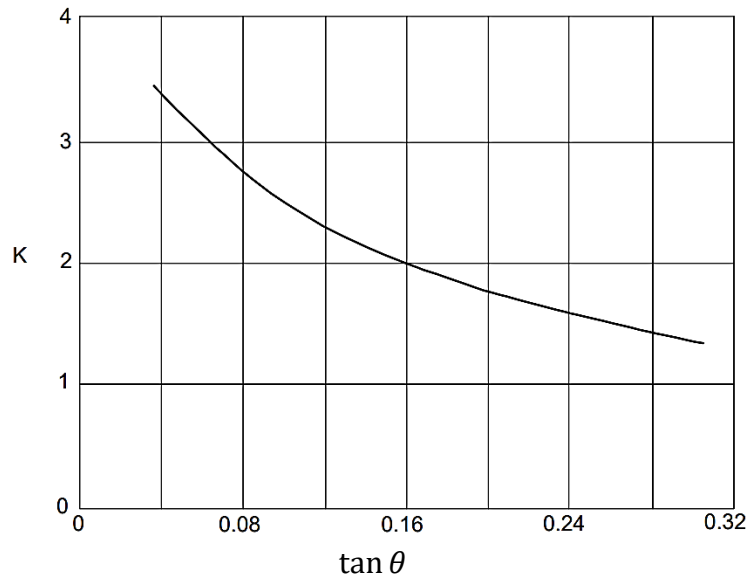

$$\frac{D'_2}{D_1} = \frac{1}{2 \cos \theta} \left[ \left( \frac{8 F_1^2 \cos^2 \theta}{1 - 2K \tan \theta} + 1 \right)^{\frac{1}{2}} - 1 \right]$$

NOTE — Above curve is based on assumption that  $K$  is independent of  $F_1$

FIG. 4 CURVE FOR DETERMINATION OF SHAPE FACTOR

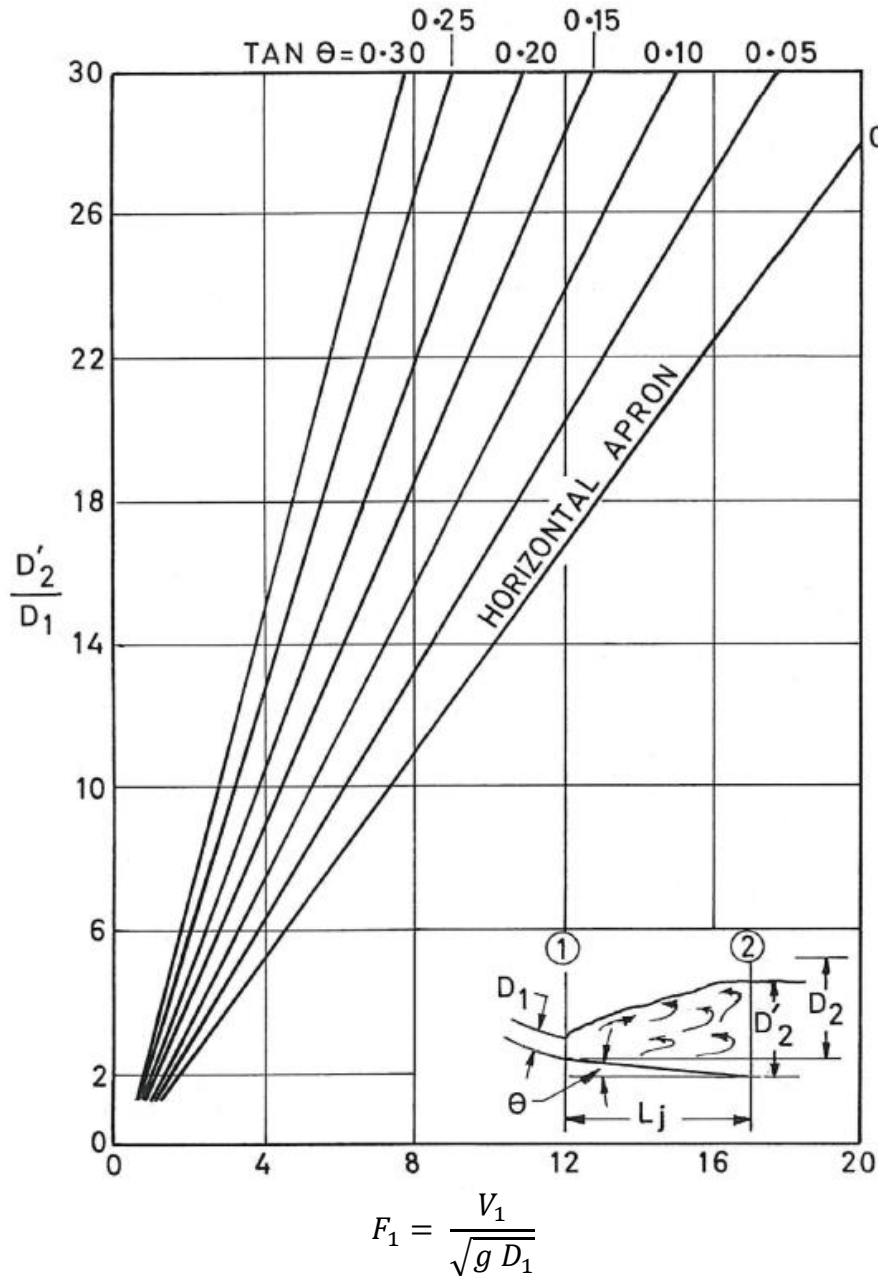

FIG. 5 RATIO OF CONJUGATE DEPTH  $D_2'$  TO  $D_1$  (BASIN III)

**3.4 Stilling Basin** — A structure in which all or part of the energy dissipating action is confined. In a stilling basin the kinetic energy first causes turbulence and is ultimately lost as heat energy.

**3.5 Hydraulic Jump Type Stilling Basin** — A basin in which dissipation of energy is accomplished basically by hydraulic jump which may be stabilized using chute blocks, basin blocks, end sill etc.



**3.6 Length of Stilling Basin** — Dimension of the basin in the direction of flow.

**3.7 Width of Stilling Basin** — Dimension of the basin perpendicular to the direction of main flow.

**3.8 Chute Blocks** — Triangular blocks installed at the upstream end of the stilling basin.

**3.9 Basin Blocks/Baffle Blocks/Baffle Piers** — Blocks installed on the basin floor between chute blocks and end sill, at a distance of  $0.8 D_2$  from toe.

**3.10 End Sill** — Solid or dentated wall constructed at the downstream end of the stilling basin.

**3.11 Froude Number** — A dimensionless number characterizing the inertial and gravitational forces in an open channel flow (see Fig. 1) and is defined as follows:

$$F = \frac{V}{\sqrt{gD}}$$

Where,

$F$  = Froude number,  
 $V$  = velocity of flow, and  
 $D$  = depth of flow.

**3.12 Shape Factor ( $K$ )** — A dimensionless parameter which varies with the Froude number and the slope of the apron. This has been plotted against slope in Fig. 4 on the assumption that it is independent of Froude number.

## 4 HYDRAULIC JUMP TYPE STILLING BASIN WITH HORIZONTAL APRON

### 4.1 General

When the tail-water rating curve approximately follows the hydraulic jump curve or is only slightly above or below it, then hydraulic jump type stilling basin with horizontal apron provides the best solution for energy dissipation. In this case the requisite depth may be obtained on a proper apron near or at the ground level so that it is quite economical. For spillways on weak bed rock conditions and weirs and barrages on sand or loose gravel, hydraulic jump type stilling basins are recommended.

### 4.2 Classification

Hydraulic jump type stilling basin with horizontal apron may be classified into the following two categories:

- a) Stilling basins in which the Froude number of the incoming flow is less than 4.5. This case is generally encountered on weirs and barrages. This basin is hereafter called as basin I.
- b) Stilling basins in which the Froude number of the incoming flow is greater than 4.5. This case is a general feature for dams. This basin is hereafter called as basin II.

NOTE — List of projects with stilling basin as energy dissipators for dam spillways is given in Annex A for information.

### 4.3 Design Criteria

**4.3.1** Factors involved in the design of stilling basins include the determination of the elevation of the basin floor, the basin length and basin appurtenances, if any.

#### 4.3.2 Determining Elevation of the Basin Floor

Knowing  $H_L$  and  $q$ ,  $D_c$ ,  $D_1$  and  $D_2$ , can be determined either from the following formulae or from Fig. 6:

$$H_L = (D_2 - D_1)^3 / (4 D_1 \cdot D_2) ;$$

$$D_c = \left( \frac{q^2}{g} \right)^{1/3} ; \text{ and}$$

$$D_2 = -\frac{D_1}{2} + \sqrt{\frac{2q^2}{D_1 g} + \frac{D_1^2}{4}}$$

Having obtained  $D_1$  and  $D_2$ , the elevation of the basin floor may be calculated by either deducting the specific energy at section 1-1 from the total energy line at that section or that at section 2-2 from the downstream total energy line.

**4.3.3** To calculate  $H_L$  from the known upstream and downstream total energy lines, the following procedure may be adopted:

- a) Where the basin is directly downstream from the crest or where the chute is no longer than the hydraulic head,  $H_L$  may be assumed equal to the difference in the upstream and downstream total energy lines, for the purpose of preliminary design; and
- b) Where the chute length (measured from upstream face up to the entrance to the stilling basin) is up to 5 times the hydraulic head (MWL – TWL), the frictional loss over the chute may be assumed to be 10 percent of the total head (MWL – apron level). For chute lengths exceeding 5 times, the frictional loss may be assumed to be 20 percent of the total head.  $H_L$  may accordingly be calculated as (MWL – TWL – friction loss), for the preliminary design. For a precise estimation; boundary layer and spillway energy loss calculations should be performed.

#### 4.3.4 Basin I

Requirements for basin length, depth and appurtenances for basin I are given below:

##### 4.3.4.1 Basin length and depth

Length of the basin may be determined from the curve given in Fig. 7(A). The basin should be provided with an end sill preferably dentated end sill. In the boulder reach the sloping face of the end sill is kept on the upstream side. Generally, the basin floor should not be raised above the level required from sequent depth consideration. If the raising of the floor becomes obligatory due to site conditions, the same should not exceed 15 percent of  $D_2$ , and the basin in that case should be further supplemented by chute blocks and basin blocks. The basin blocks should not be used if the velocity of flow at the location of basin blocks exceeds 15 m/s and in that case the floor of the basin should be kept at a depth equal to  $D_2$  below the tail-water level. The tail-water depth should not generally exceed 10 percent of  $D_2$ .

##### 4.3.4.2 Basin appurtenances

Requirements for basin appurtenances, such as chute blocks, basin blocks, and end sill are given below {see Fig. 7(B)}:

- a) *Chute blocks* — The chute blocks should be kept at a height equal to  $2D_1$  on the glacis slope. Their top length should also be equal to  $2D_1$ . The width of the chute blocks should be kept equal to  $D_1$  and their spacing as  $2.5 D_1$ . A space equal to  $D_1/2$  should be left along each wall.
- b) *Basin blocks* — The height of basin blocks in terms of  $D_1$  may be obtained from Fig. 8(B). The width and spacing of the basin blocks should be equal to their height. The upstream face of all the basin blocks shall be vertical and in one plane. A half space is recommended adjacent to the walls. The upstream face of the basin blocks should be set at a distance of  $0.8 D_2$ , from the downstream face of the chute blocks.
- c) *End sill* — The height of the dentated end sill is recommended as  $0.2D_2$ . The maximum width and spacing of dents shall be according to Fig. 7(B). A dent is recommended adjacent to each side wall. In the case of narrow basin, it is advisable to reduce the width and spacing but in the same proportion. It is not necessary to stagger the end sill dents with reference to chute blocks.

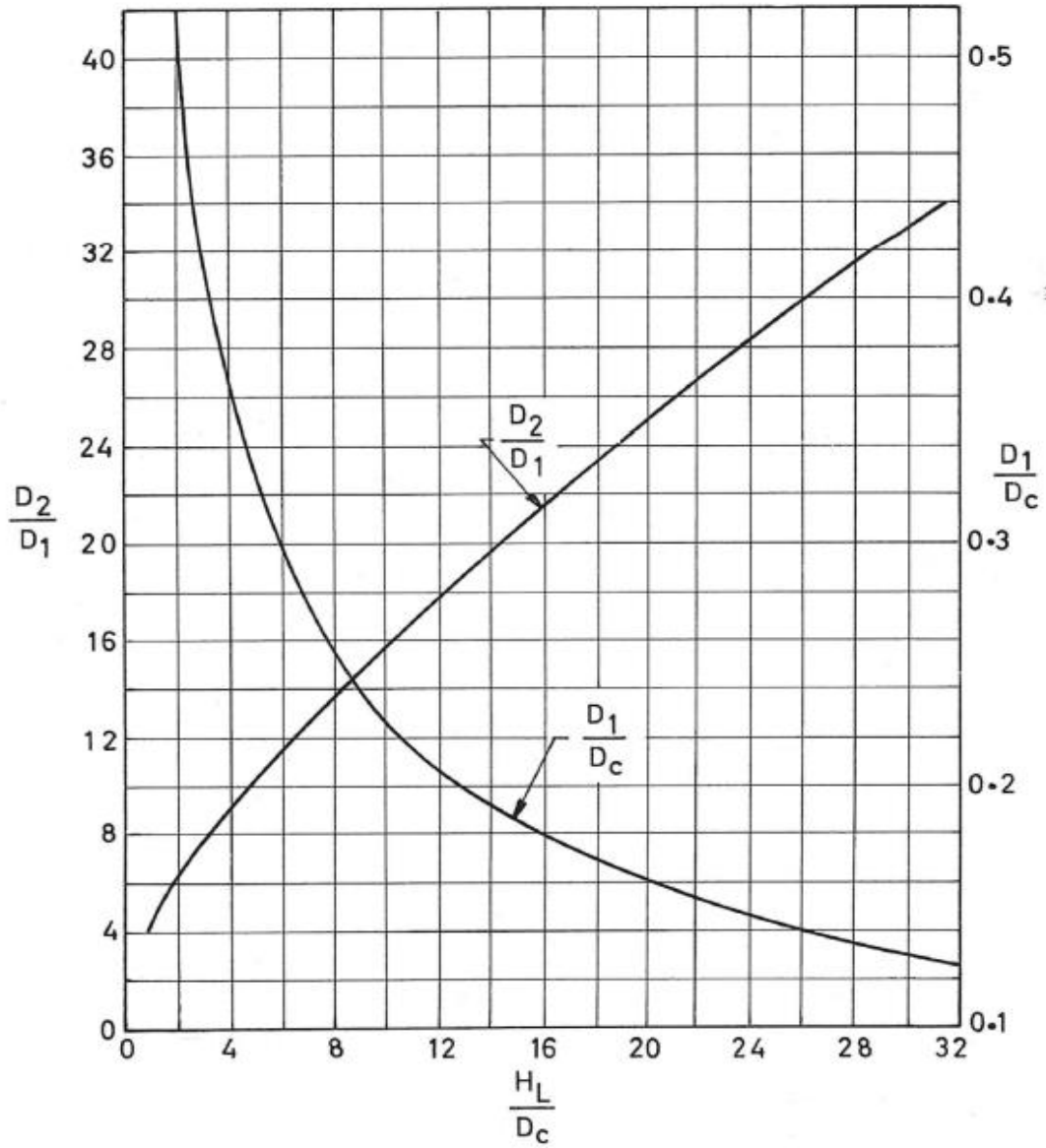
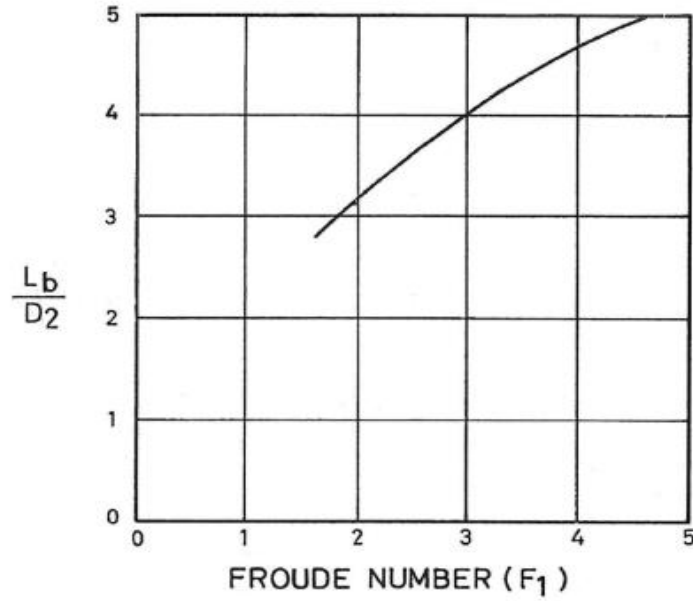
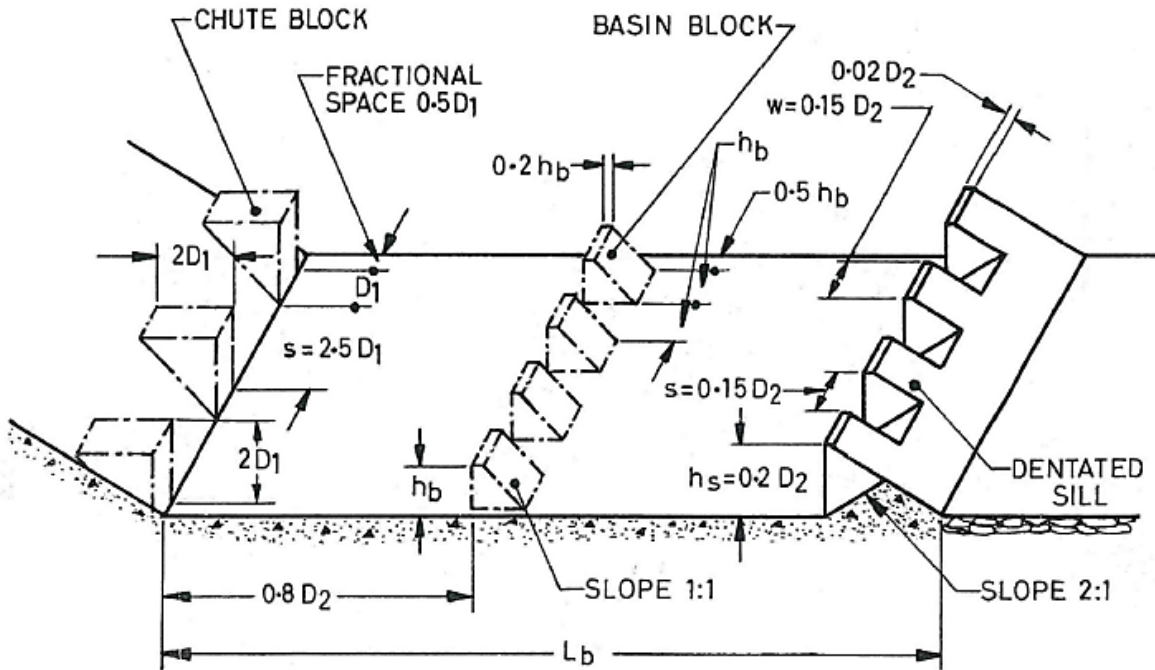

FIG. 6 CURVE FOR DETERMINATION OF SEQUENT DEPTH (HORIZONTAL APRON)



7A RECOMMENDED LENGTH FOR BASIN I



7B APPURTENANCES FOR BASIN I

FIG. 7 DIMENSIONAL SKETCH FOR BASIN I

### 4.3.5 Basin II

Requirements for basin length depth and appurtenances for basin II are given below:

#### 4.3.5.1 Basin length and depth

Length of the basin is determined from the curve given in Fig. 8(A). The basin should be provided with chute blocks and end sill. The maximum raising of the basin floor shall not exceed 15 percent of  $D_2$ , and the basin in that case will be further supplemented by basin blocks. However, when the flow velocity at the location of basin blocks exceeds 15 m/s, no basin blocks are recommended and in that case the floor of the basin should be kept at a depth equal to  $D_2$  below the tail-water level. The tail-water depth should not generally exceed 10 percent of  $D_2$ .

#### 4.3.5.2 Basin appurtenances

Requirements for basin appurtenances, such as chute blocks, basin blocks and end sill are given below {see Fig. 8(B)}:

- a) *Chute blocks* — The height, width and spacing of the chute blocks should be kept equal to  $D_1$ . The width and spacing may be varied to eliminate fractional blocks. A space equal to  $D_1/2$  is preferable along each wall;
- b) *Basin blocks* — The height of basin blocks in terms of  $D_1$  can be obtained from Fig. 8(B). The width and spacing should be kept three-fourth of the height. These should be placed at distance of  $0.8 D_2$ , downstream from the chute blocks; and
- c) *End sill* — Same as **4.3.4.2** (c).

The ratio of tail water depth  $D_1$  with respect to Froude number (for basin I and basin II) are shown in Fig. 9

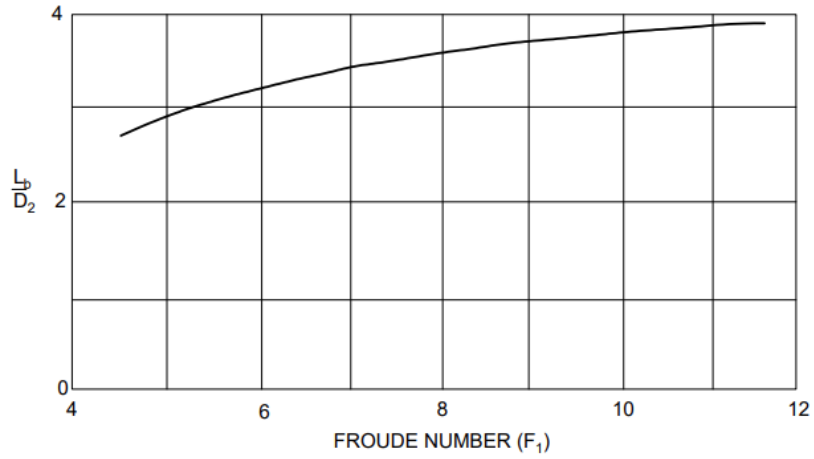

8A RECOMMENDED LENGTH FOR BASIN II

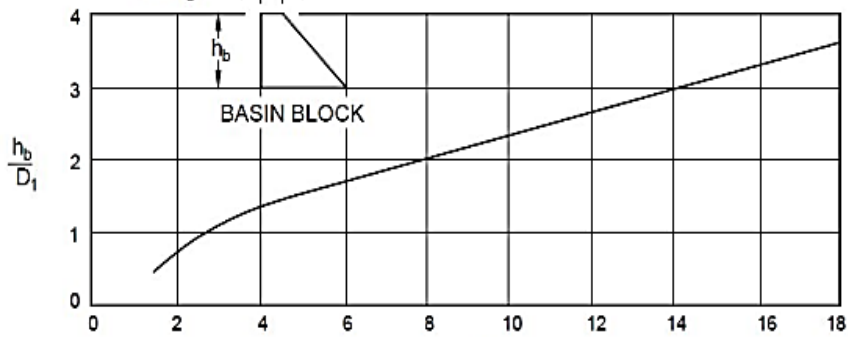
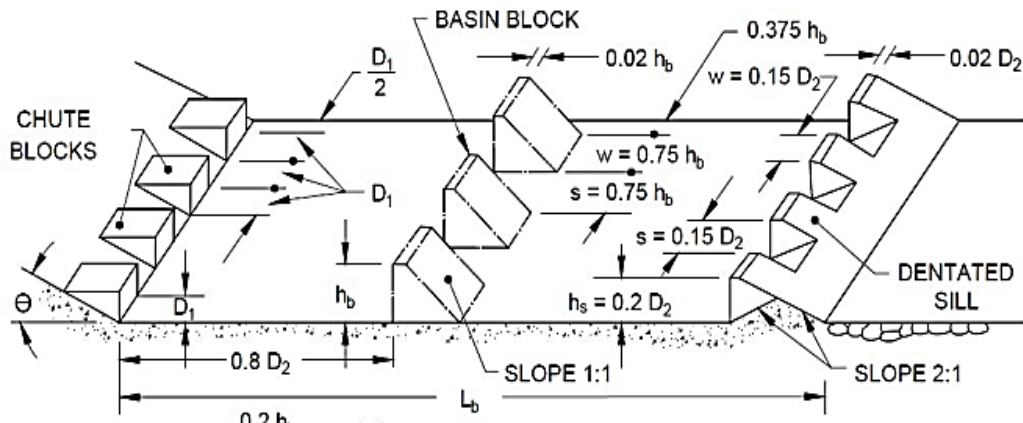

$$F_1 = \frac{V_1}{\sqrt{gD_1}}$$

8B APPURTENANCES FOR BASIN II

FIG. 8 DIMENSIONAL SKETCH FOR BASIN II

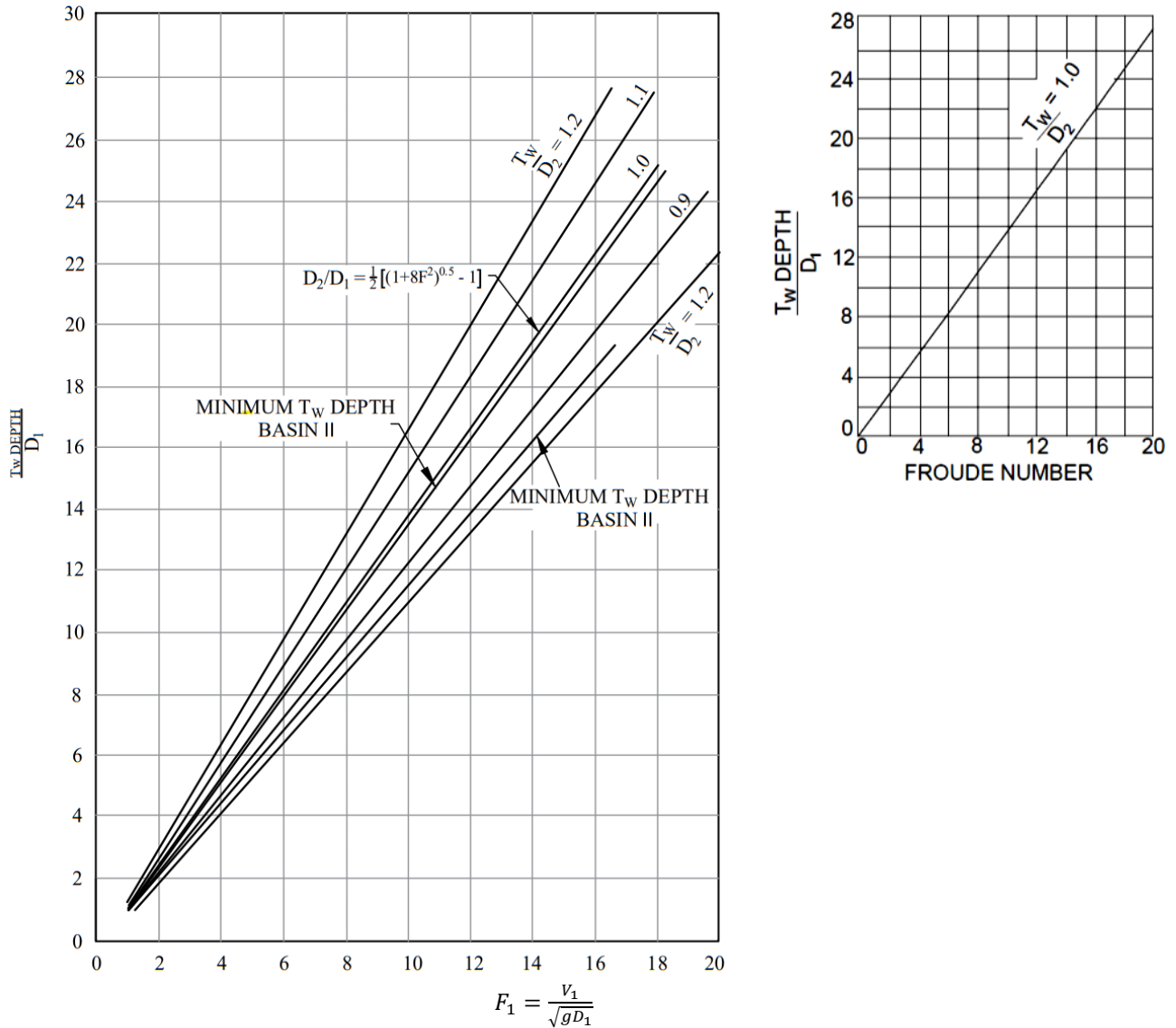

FIG. 9 RATION OF TAIL WATER DEPTH TO  $D_1$  VS FROUDE NUMBER (BASIN I AND II)

## 5 HYDRAULIC JUMP TYPE STILLING BASINS WITH SLOPING APRON

### 5.1 General

When the tail-water is too deep as compared to the sequent depth  $D_2$ , the jet left at the natural ground level would continue to go as a strong current near the bed forming a drowned jump which is harmful to the river bed. In such a case, a hydraulic jump type stilling basin with sloping apron should be preferred as it would allow an efficient jump to be formed at suitable level on the sloping apron.



## 5.2 Classification

The hydraulic jump on a sloping apron may occur in four different forms depending on the tail-water conditions (see Fig.10). The action in cases *C* and *D* is same if it is assumed that horizontal floor begins at the end of the jump in case *D*. Case *B* is virtually case *A* operating with excessive tail-water depth. Case *A* has been dealt with previously in 4. The criteria for the design of stilling basins for case *D* and case *B* hereafter known as Basin III and Basin IV respectively are given in 5.3.

**5.2.1** Basin III is recommended for the case where tail-water curve is higher than the  $D_2$  curve at all discharges.

**5.2.2** Basin IV is suitable for the case where the tail-water depth at maximum discharge exceeds  $D_2$ , considerably but is equal to or slightly greater than  $D_2$ , at lower discharges.

## 5.3 Design Criteria

**5.3.1** It is not possible to standardize design criteria for sloping aprons to the same extent as in the case of horizontal apron. In this case, greater individual judgment is required. The slope and overall shape of the apron are determined from economic consideration, the length being judged by the type and soundness of the river bed downstream. The following design criteria should serve only as a guide in proportioning the sloping apron designs.

### 5.3.2 Basin III

In the design of Basin III, the following procedure may be adopted:

- a) Assume a certain level at which the front of jump will form for the maximum tail water depth and discharge.
- b) Determine  $D_1$  from the known upstream total energy line by applying Bernoulli's theorem and calculate  $F_1$ . Then find out conjugate depth  $D_1$  from equation given in 3.3.
- c) Assume a certain slope and determine the conjugate depth  $D_2$ , and length of the jump for the above Froude number from Fig. 5 and Fig. 3 respectively. The length of the apron should be kept equal to 60 percent of the jump length.
- d) Test whether the available tail water depth at the end of the apron matches the conjugate depth  $D_2$ . If not, change the slope or the level of the upstream end of the apron or both. Several trials may be required before the slope and the location of the apron are compatible with the hydraulic requirement.
- e) The apron designed for maximum discharge may then be tested at lower discharges, say 25 percent, 50 percent and 75 percent of design discharge. If the

tail-water depth is sufficient or is in excess of the conjugate depth for the intermediate discharges, the design is acceptable. If not, a flatter slope at lower apron level should be tried or basin IV may be adopted.

- f) The basin should be supplemented by a solid or dentated end sill of height equal to 0.05 to 0.2  $D_2$ , with an upstream slope of 2 : 1 to 3 : 1.

The ratio of tail water depth  $D_1$  with respect to Froude number (for basin III) are shown in Fig. 11.

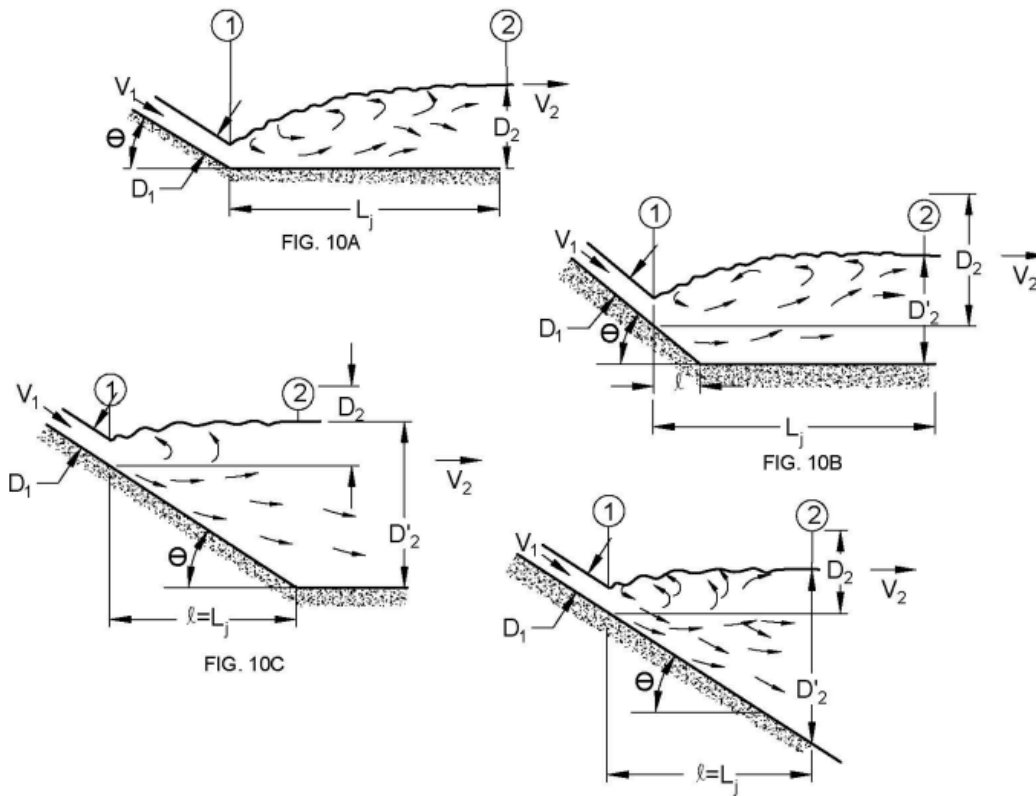
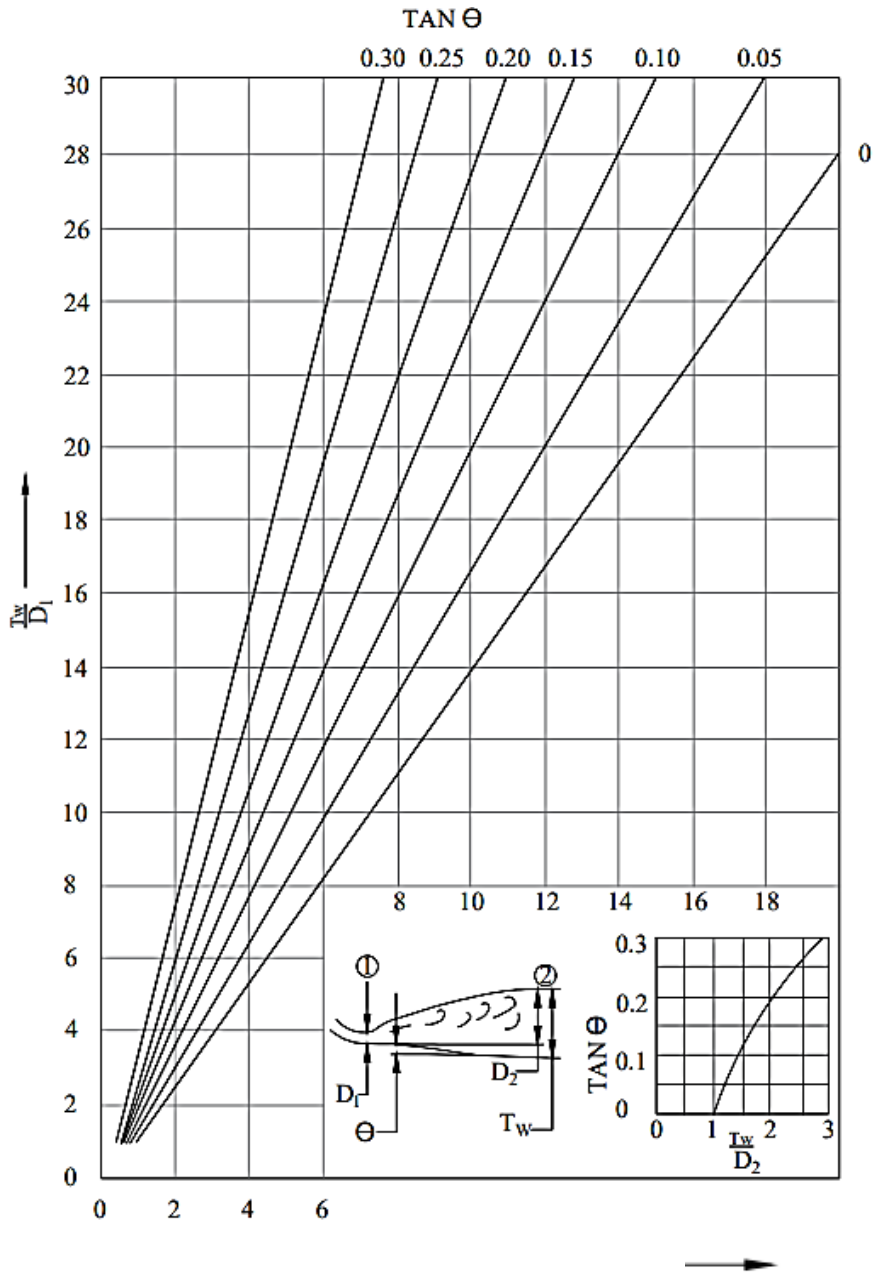

FIG. 10 DIFFERENT FORMS OF HYDRAULIC JUMP ON SLOPING APRON



$$F_1 = \frac{V_1}{\sqrt{gD_1}}$$

FIG. 11 TAIL WATER DEPTH TO  $D_1$  VERSUS FROUDE NUMBER FOR SLOPING APRON (BASIN III)

### 5.3.3 Basin IV

In the design of Basin IV, the following procedure may be adopted:

- a) Determine the discharge at which the tail-water depth is most deficient.
- b) For the above discharge, determine the level and length of the apron on the basis of criteria given in 4.

- c) Assume a certain level at which the front of jump will form for the maximum tail-water depth and discharge.
- d) Determine  $D_1$  from the known upstream total energy line by applying Bernoulli's theorem and calculate  $F_1$ . Then find out conjugate depth  $D_2$ , from equation given in 3.3.
- e) Determine a suitable slope (by trial and error) so that the available tail-water depth matches the required conjugate depth  $D_2$ , determined from Fig. 12.
- f) Determine the length of the jump for the above slope from Fig. 3. If the sum of the lengths of inclined portion and horizontal portion is equal to about 60 percent of the jump length, the design is acceptable. If not, fresh trials may be done by changing the level of the upstream end of the jump formation.
- g) The basin should be supplemented by a solid or dentated end sill of height 0.05 to  $0.2 D_2$ , and upstream slope of 2:1 to 3:1.

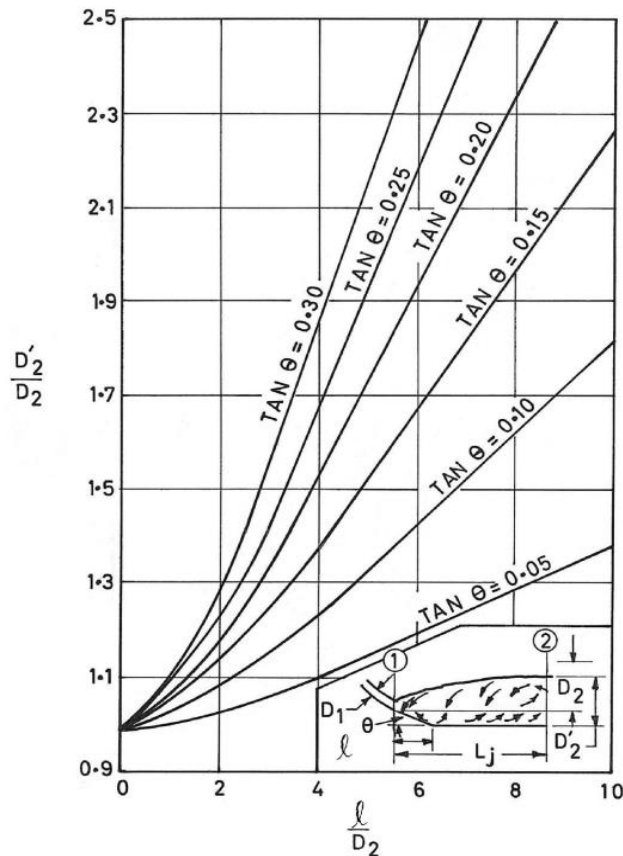

FIG. 12 TAIL WATER REQUIREMENT FOR SLOPING APRON (BASIN IV)

## 6 PROVISION OF DIVIDE WALL/ SUBMERSIBLE DIVIDE WALLS

Provision of divide walls to separate the stilling basin in number of bays helps in reducing the extent of return eddies formed in the stilling basin due to closure of few spans. This is especially important in spillways having large number of spans. The divide walls reduce the extent of return eddies thereby minimizing the tendency of deposition of material into

stilling basin and consequent damage due to abrasion. Segregation of stilling basin into a number of bays also facilitates easy and quick inspection or repair by restricting the zone of dewatering. If the spillway is designed for dual purpose of passing the floods and flushing of sediment, provision of appurtenances like chute and baffle blocks is not advisable. As a result, the stilling basin becomes excessively long and often deep-seated below the general river bed, making it vulnerable to deposition of silt during flushing operation. A trade-off is desirable between the hydraulic efficiency of energy dissipation and the self-cleansing potential of the stilling basin during flushing operation. Cylindrical end sills are generally preferred for easy movement of sediment out of the basin.

## 6.1 Cylindrical End Sill

A hydraulic jump stilling basin may have to be adopted where geological conditions are not favourable. The high unit discharge passing down a low head during flushing, results in a low Froude number condition. The stilling basins for the Froude number in the range of 2.5 to 4.5 are rather difficult to design to ensure satisfactory performance for the entire range of discharge. Because of the requirement of passing high sediment flows, use of energy dissipating appurtenances like chute and baffle blocks is not advisable. As a result, the stilling basin becomes excessively long and often deep-seated below the general river bed, making it vulnerable to deposition of silt during flushing operation. Therefore, a trade-off is desirable between the hydraulic efficiency of energy dissipation and the self-cleansing potential of the stilling basin during flushing operation. Cylindrical end sills are generally preferred for easy movement of sediment out of the basin. Fig. 13 shows the definition sketch for the cylindrical end sill.

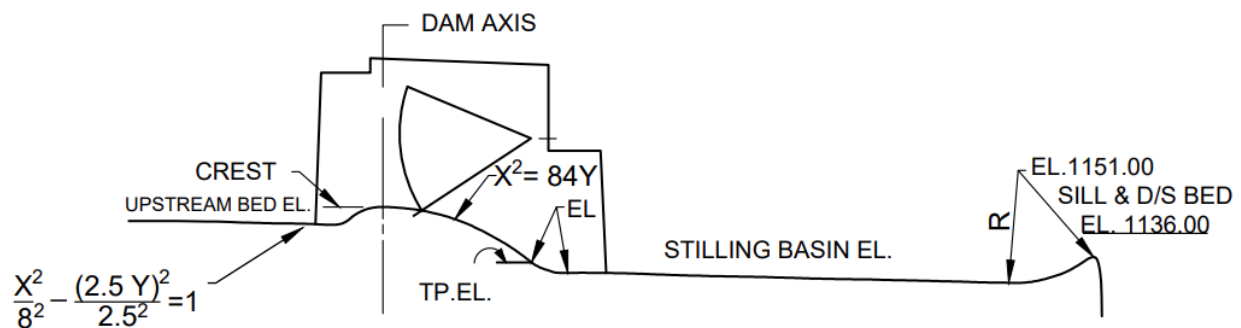

FIG. 13 TYPICAL CROSS – SECTION OF SPILLWAY AND STILLING BASIN WITH CYLINDRICAL END SILL

## 6.2 Bulking of Flow

Air bulking occurs where the turbulent water boundary reaches the water surface and air is introduced into the flow (entrained air) as a result of this turbulence. Bulking generally increase the depth of flow and to adjust the increased flow depths, the following equation can be applied:

$$\frac{d_b}{d} = \frac{1}{1 - \bar{C}}$$

Where,

$d$  = flow depth (non-bulked), in 'm';

$d_b$  = bulked flow depth, in 'm'; and

$\bar{C}$  = mean air concentration.

There is an apparent reduction in the coefficient of friction for highly aerated flow. Adjustments to the flow depth can be made to account for the reduction related to air concentration as shown in Fig. 14. The heights of the training walls may be finalised based on the water surface profiles observed from the model studies, bulking of flow due to air entrainment in the prototype and free board. The effect of bulking of flow due to air entrainment may be considered above a value of 25 percent.

### 6.2.1 Stilling Basin Free Board

Freeboard is ordinarily provided so that the stilling basin walls is not overtopped by surges, splash and spray, and wave action set up by the turbulence of the jump. The surface roughness of the flow is related to the energy dissipated in the jump and to the depth of flow in the basin. The following empirical expression provides values that have proved satisfactory for most basins:

$$\text{Free board} = 0.1(V_1 + D_2)$$

Where,

$V_1$  = Velocity of flow entering the basin upstream of the jump, in m/s; and

$D_2$  = Conjugate depth, in m.

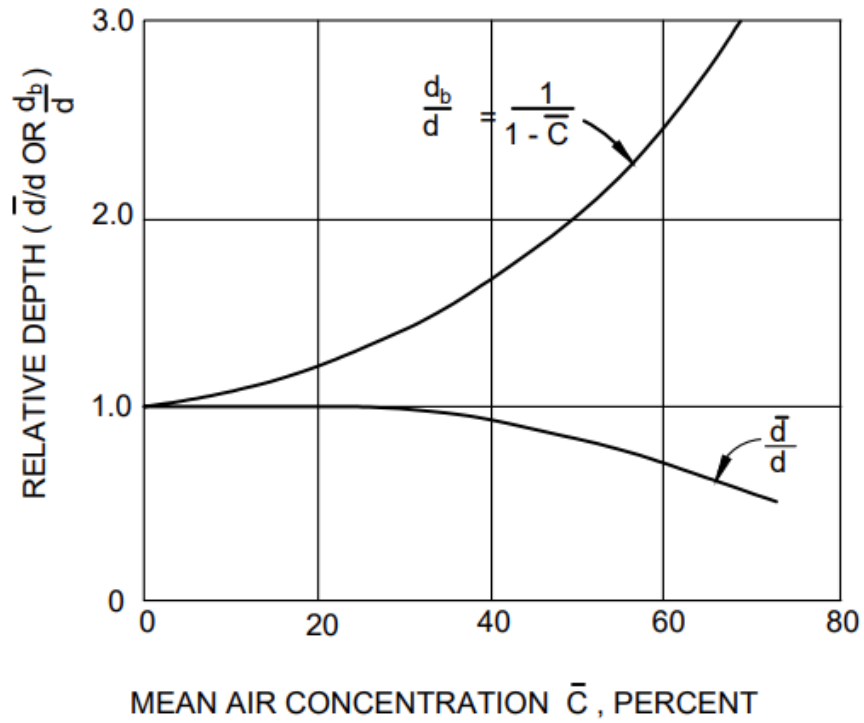
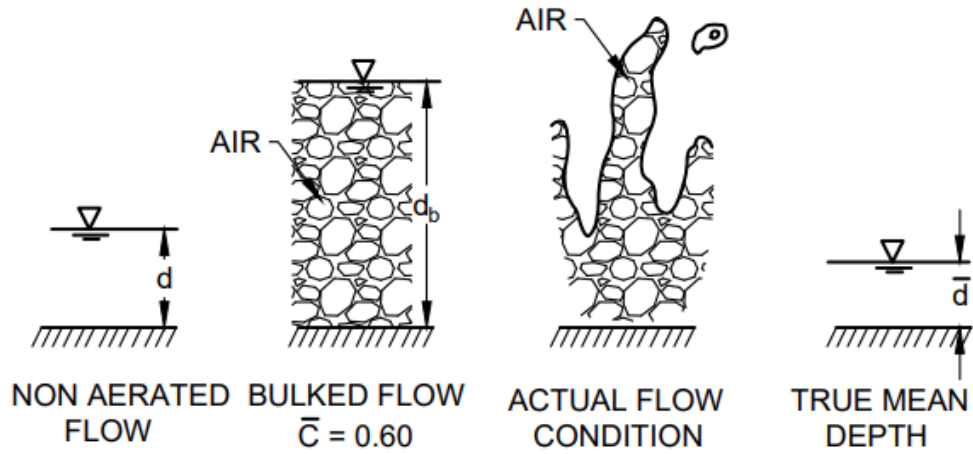

FIG. 14 AIR CONCENTRATION IN FLOW (FALVEY, 1980)

SEP 2024

**ANNEX A**  
(Clause 4.2 Note)

**Table 1 List of Projects with Stilling Basin as Energy Dissipator for Existing and Proposed Dam Spillways**

| SI No. | Name of the Structure                          | m <sup>3</sup> /s | m <sup>3</sup> /s/m | D <sub>1</sub> | D <sub>2</sub> | F <sub>1</sub> | L <sub>b</sub> | $\frac{L_b}{D_2}$ | D <sub>b</sub> | $\frac{D_b}{D_2}$ | Basin Appurtenances |                   |                   |
|--------|--|-------------------|---------------------|----------------|----------------|----------------|----------------|-------------------|----------------|-------------------|---------------------|-------------------|-------------------|
|        |  |                   |                     |                |                |                |                |                   |                |                   | $\frac{h_c}{D_1}$   | $\frac{h_b}{D_1}$ | $\frac{h_s}{D_2}$ |
| (1)    | (2)  | (3)               | (4)                 | (5)            | (6)            | (7)            | (8)            | (9)               | (10)           | (11)              | (12)                | (13)              | (14)              |
| i)     | Teesta Low Dam Project, Stage-III, West Bengal | 10430             | 106.00              | 4.78           | 19.71          | 3.25           | 70.00          | 3.55              | 19.71          | 1.00              | –                   | –                 | 0.18              |
| ii)    | Teesta Low Dam Project, Stage-IV, West Bengal  | 15400             | 122.22              | 4.77           | 23.00          | 3.75           | 70.00          | 3.04              | 31.00          | 1.35              | –                   | –                 | 0.17              |
| iii)   | Kotlibhel–IB, Uttarakhand                      | 26615             | 204.73              | 6.56           | 32.95          | 3.89           | 106.60         | 3.24              | 44.20          | 1.34              | –                   | –                 | 0.28              |
| iv)    | Kotlibhel–II, Uttarakhand                      | 39750             | 212.44              | 6.88           | 33.30          | 3.76           | 80.00          | 2.40              | 41.38          | 1.24              | –                   | –                 | 0.15              |
| v)     | Jigaon, Maharashtra                            | 24131             | 82.50               | 3.71           | 17.58          | 3.69           | 91.00          | 5.18              | 14.60          | 0.83              | –                   | –                 | 0.23              |
| vi)    | Omkareshwar, M.P.                              | 88315             | 154.94              | 5.67           | 26.65          | 3.66           | 70.00          | 2.63              | 24.00          | 0.90              | –                   | –                 | 0.26              |
| vii)   | Chamera-III, H.P.                              | 11400             | 240.00              | 7.80           | 35.08          | 3.50           | 50.00          | 1.43              | 39.00          | 1.11              | –                   | –                 | 1.56              |
| viii)  | Sewa-II, J and K                               | 4020              | 87.39               | 2.99           | 21.37          | 5.39           | 60.00          | 2.81              | 23.50          | 1.10              | –                   | –                 | 0.19              |
| ix)    | Dhanikari, Andaman and Nicobar                 | 225               | 15.00               | 0.58           | 8.62           | 10.87          | 30.00          | 3.48              | 8.80           | 1.02              | –                   | –                 | 0.46              |
| x)     | Hirakund Additional Spillway, Odisha           | 9122              | 100.24              | 3.68           | 21.82          | 4.53           | 91.00          | 4.17              | 24.75          | 1.13              | 1.02                | –                 | 0.21              |
| xi)    | Kurichu, Bhutan                                | 12200             | 151.55              | 5.36           | 26.97          | 3.89           | 104.00         | 3.86              | 25.00          | 0.93              | –                   | –                 | 0.15              |
| xii)   | Chamera-II, H.P.                               | 9000              | 115.38              | 4.83           | 21.40          | 3.46           | 94.04          | 4.40              | 22.00          | 1.03              | –                   | –                 | 0.23              |
| xiii)  | Garudeshwar, Gujarat                           | 62807             | 103.30              | 4.44           | 20.02          | 3.52           | 63.50          | 3.17              | 27.34          | 1.37              | –                   | –                 | 0.14              |
| xiv)   | Icha, Bihar                                    | 21682             | 98.55               | 3.96           | 20.48          | 4.00           | 80.00          | 3.91              | 19.10          | 0.93              | –                   | –                 | 0.21              |