

भारतीय मानक ब्यूरो  
BUREAU OF INDIAN STANDARDS

*Draft For Comments Only*

Doc: TXD 01 (25206) WC  
March 2024

*(Not to be reproduced without permission of BIS or used as Standard)*

भारतीय मानक मसौदा

वस्त्रादि — बिना कटे भारतीय जूट, मेस्टा/बिमली के परीक्षण के लिए  
भौतिक तरीके

[ IS 7032 (भाग 1 से 9) का दूसरा पुनरीक्षण ]

*Draft Indian Standard*

TEXTILES — PHYSICAL METHODS OF TEST FOR  
UNCUT INDIAN JUTE, *MESTA/BIMLI*

[ *Second Revision of IS 7032 (Part 1 to 9)* ]

ICS 59.060.10

---

Physical Methods of Test Sectional Committee,  
TXD 01

Last date for receipt of comments  
**06 May 2024**

---

FOREWORD

*(Formal clauses will be added later)*

This standard was originally published in 1973 and subsequently revised in 1976. Initially, this standard consisted of nine parts (Parts 1 to 9) which covered methods of test for various characteristics of Jute fibres. In the first revision, the method for determination of brightness (colour) (Part 9) had been withdrawn.

This standard supersedes IS 7032 (Part 1-8) : 1986 'Physical methods of test for uncut Indian jute, Mesta and Bimli (first revision)'. After publication of this standard, it shall be treated as withdrawn.

IS 271 'Grading of white, *tossa* and *daisee* uncut Indian Jute (*fifth revision*)', IS 9846 'Grading of uncut Indian *Mesta*', and IS 11596 'Grading of uncut Indian *Bimli*' have been published for grading of different type of Jute fibres.

These standards have taken into consideration the characteristics such as strength, lustre, colour, density, fineness, root content and defects, etc, for grading of fibres. Previously, these grading standards prescribe the ‘Hand and eye method’ for grading and allot scores for different characteristics but this revision has been made in the light of experience gained since its publication and to incorporate the following major changes also:

- a) Incorporated the test method of various digital Jute grading instruments developed by ICAR-NINFET. These are digital automatic bundle strength tester, digital fineness meter and digital colour meter for grading the Jute fibre as these provide accurate and reliable results;
- b) ‘Part 9 Colour’ for measurement of colour has been included;
- c) All amendments have been incorporated;
- d) Test reports have been modified; and
- e) References to Indian standards have been updated.

This standard contains the below-mentioned parts and is aimed at obtaining instrumental measures for characteristics of Jute, *Mesta/Bimli* fibres for the purpose of grading. To achieve this aim only those methods, which are simple and could be adopted by the graders with the minimum of effort and where scoring could be possible, have been selected after a survey of the work done by research institutions, the published literature and also keeping in view the type of instruments available with the industry:

Part 1	General
Part 2	Reed Length
Part 3	Root Content
Part 4	Defects
Part 5	Foreign Matter
Part 6	Bulk Density
Part 7	Bundle Strength
Part 8	Fineness
Part 9	Colour

In reporting the result of a test or analysis made in accordance with this standard, if the final value, observed or calculated, is to be rounded off, it shall be done in accordance with IS 2 : 2022 ‘Rules for rounding off numerical values (*second revision*)’.

*Draft Indian Standard*

# TEXTILES — PHYSICAL METHODS OF TEST FOR UNCUT INDIAN JUTE, *MESTA/BIMLI*

## PART 1 GENERAL

[*Second Revision of IS 7032 (Part 1)*]

### 1 SCOPE

This standard (Part 1) prescribes the definitions of terms, sampling procedure and atmospheric conditions for testing of uncut Indian Jute (white and *tossa*), *Mesta/Bimli* fibres.

### 2 REFERENCES

The standards listed below contain provisions which, through reference in this text, constitute provisions of this standard. At the time of publication, the editions indicated were valid. All standards are subject to revision, and parties to agreements based on this standard are encouraged to investigate the possibility of applying the most recent editions of the standards indicated below:

<i>IS No.</i>	<i>Title</i>
IS 196 : 1966	Atmospheric conditions for testing ( <i>revised</i> )
IS 271 : 2020	Textiles — Grading of <i>White, Tossa</i> and <i>Daisee</i> Uncut Indian Jute ( <i>fifth revision</i> )
IS 6359 : 2023	Method for conditioning of textiles ( <i>first revision</i> )
IS 9846 : 1981	Grading of uncut Indian <i>Mesta</i>
IS 11596 : 1986	Specification for grading of uncut Indian <i>Bimli</i>

### 3 TERMINOLOGY

For the purpose of this standard, the following definitions shall apply.

### 3.1 Fibres

**3.1.1 *Bimli*** — It is a substitute for Jute obtained from the bark of *Hibiscus sabdarifa*. It is generally inferior and coarser than Jute. Chemically the fibre is different from Jute in its low lignin content.

**3.1.2 *Jute*** — A multicellular fibre obtained from the bast of various species of *Corchorus*, of which the round pod Jute (*Corchorus capularis* or white Jute) and the long pod Jute (*Corchorus clitorius* or *TOSSA* Jute) are the most important. The fibre strands are long usually varying from 1.5 m to 3.5 m.

**3.1.3 *Mesta*** — It is a substitute for Jute obtained from the bark of *Hibiscus cannabinus*. It is generally inferior and coarser than Jute. Chemically the fibre is different from Jute in its low lignin content.

### 3.2 General Terms

**3.2.1 *Colour*** — The property of a fibre which distinguishes its appearance as creamy, white, grey, etc.

#### NOTES

**1** The colour description of white, *TOSSA* Jute in relation to the terms used for the purpose of grading in IS 271 is given below:

<i>Term</i>	<i>Colour Description</i>	
	<i>White Jute</i>	<i>TOSSA Jute</i>
Very good	Light creamy to white	Golden to reddish white
Good	Creamy pink to brownish white	Reddish to brownish white
Fairly good	Brownish to reddish white with some light grey	Reddish to brownish white with some light grey
Fair average	Brownish to light grey	Light grey to copper colour
Average	Grey to dark grey	Grey to dark grey

**2** The colour description of *Mesta* fibres in relation to the terms used for the purpose of grading in IS 9846 is given below:

Good	Creamy to whitish
Fair	Light grey
Average	Greyish to dark

**3** The colour description of *Bimli* fibres in relation to the terms used for the purpose of grading in IS 11596 is given below:

Good	Creamy to whitish
Average	Greyish to dark

**3.2.2 Density** — Mass per unit volume of the fibre including its airspaces. The higher density is a characteristic of better quality fibre. In the hand and eye method for grading of raw Jute, heaviness or body of the fibre is assessed. This is more or less equivalent to the bulk density of the fibre.

**3.2.3 Fineness** — A measure of diameter (width) or mass per unit length, or both of the fibre filament.

NOTE — The finer the fibre, the better is its quality.

**3.2.4 Foreign Matter** — These are dust and mud, moss and stick which are mostly lost during processing and are thus subject to claims.

**3.2.5 Lustre** — The display of different intensities of light reflected both specularly and diffusely from different parts of a surface exposed to the same incident light. Due to this reflection of light the surface of textiles (fibre, yarn or fabric) looks glossy or shining.

NOTE — In case of Jute fibres, higher lustre is generally a characteristic of a better quality fibre.

**3.2.6 Natural Dust** — The dust which might get associated with the fibre during the process of its production.

**3.2.7 Parcel** — A consignment containing certain number of bales, bundles or drums.

**3.2.8 Reed** — The fibre system from the individual Jute, *Mesta/Bimli* plants.

**3.2.8.1 Reed length** — The length of the reed from bottom to top (excluding the underground root portion in case of *Bimli*).

**3.2.8.2 Effective reed length** — The length of the reed after the root and hard barky croppy ends have been removed.

**3.2.9 Root** — The hard barky region at the lower end of the reed which requires additional softening treatment, normally called, 'cuttings'. This includes the underground root portion in case of *Bimli*.

**3.2.10 Strength** — The ability of the fibres to resist strain or rupture induced by external force.

**3.2.10.1** The strength aspect of the fibres is classified their tenacity. strain or rupture depending upon

#### NOTES

<sup>1</sup>Tenacity is the breaking load of a material under test divided by the linear density of the unstrained material, expressed as grams per tex.

2 Linear density is the mass per unit length; the quotient obtained by dividing the mass of fibre or yarn by its length. When the mass is expressed in grams and the length in kilometres, the resulting value, the quotient, is expressed as tex.

3 IS 271 specifies the terms 'very good', 'good', 'fairly good', 'fair average', 'average' and 'weak mixed' for the purpose of grading Jute fibres.

4 IS 9846 specifies the terms 'very good', 'good', 'fairly good', 'average' and 'weak mixed' for the purpose of grading *Mesta* fibres.

5 IS 11596 specifies the terms 'good', 'fair', 'average' and 'weak mixed'.

### 3.3 Defects

- a) Major — Entangled croppy end fibre, centre root, dazed and overrated fibres, mossy fibre, runners, knots, entangled sticks and hunka.
- b) Minor — Croppy fibre, weak croppy fibre, gummy fibre, loose sticks, specks, leaf and loose leaf.

**3.3.1** *Centre Root (Bukchhal)* — The hard barky region in the middle part of the reed which requires additional softening treatment.

**3.3.2** *Croppy Fibre* — Fibre with top ends rough and hard (but not barky) caused by careless retting.

**3.3.2.1** *Weak croppy fibre* — Fibre which has become unusually weak over a length of about 30 cm at the top end.

**3.3.2.2** *Entangled croppy end fibre* — Fibre with an unusually entangled croppy end.

**3.3.3** *Dazed Fibre* — Fibre which is weak in strength and dull in appearance, due to usually being stored in moist condition.

**3.3.4** *Gummy Fibre* — Fibres held together by undissolved pectineous matter.

**3.3.5** *Hunka* — The very hard barky fibre running continuously from the lower end to almost the tip of the reed.

**3.3.6** *Knots* — Stiff barky spots in the body of the reed which break the continuity of the fibres when opened.

**3.3.7** *Leaf and Loose Leaf* — It is the dark grey leafy or paper like substance (remnant of the skin of the plant) appearing on the strand. Loose leaves are those that lie loosely on the fibre and are easily removable.

**3.3.8 Mossy Fibre** — A type of vegetation which sometimes gets attached to the plant. Its portions may remain on the fibre even after retting and washing. It can be separated by hand.

**3.3.9 Over-Retted Fibre** — Fibre which has lost its strength and brightness on decomposition due to prolonged retting.

**3.3.10 Runners** — Hard barky fibre running from the lower end to the middle region, more or less continuously.

**3.3.11 Specks** — Soft barky spots in the body where fibres can be separated with some effort without breaking their continuity, though they may remain as weak spots.

**3.3.12 Sticker, Entangled Sticks and Loose Sticks** — Sticks are remnants of woody part of Jute, *Mesta/Bimli* plant over which fibre sheath is formed. Entangled sticks are broken sticks which are linked with fibre mass and are not easily removable. Loose sticks are broken sticks easily removable by shaking.

#### 4 CONDITIONING AND TESTING OF TEST SPECIMENS

The test shall be carried out in prevailing atmospheric conditions. However, in case of dispute, the conditioning and testing shall be carried out at standard atmospheric conditions of 65 %  $\pm$  2 % relative humidity and 27 °C  $\pm$  2 °C temperature (*see* IS 196 and IS 6359).

#### 5 SAMPLING

**5.1 Lot** — The quantity of raw Jute, *Mesta/Bimli* of one type and quality delivered to one buyer against one dispatch note shall constitute a lot.

**5.2** The samples for testing shall be drawn in accordance with Table 1.

**Table 1 Sampling of Jute, *Mesta/Bimli***  
(*Clause 5.2*)

Sl No.	No. of Bales in the Lot	No. of Bales to be Drawn and Opened	No. of <i>MORAHs</i> to be Drawn	No. of Strands to be Drawn
(1)	(2)	(3)	(4)	(5)
i)	Up to 10	1	5	30
ii)	11 to 20	2	10	30
iii)	21 to 100	3	15	30
iv)	101 to 150	4	20	40
v)	151 to 200	5	25	50
vi)	Above 200	—	—	50 ( <i>see</i> Note)

NOTE — The number of bales and *MORAHs* shall be so drawn as to get 50 strands.

*Draft Indian Standard*

## **TEXTILES — PHYSICAL METHODS OF TEST FOR UNCUT INDIAN JUTE, *MESTA/BIMLI***

### **PART 2 REED LENGTH**

[*Second Revision of IS 7032 (Part 2)*]

#### **1 SCOPE**

This standard (Part 2) prescribes a method for the determination of reed length of Jute, *Mesta/Bimli* fibre strands.

#### **2 EQUIPMENT**

**2.1** The following set of equipment are required:

- a) A smooth platform or floor;
- b) Measuring tape; and
- c) A pair of scissors.

#### **3 PROCEDURE**

##### **3.1 Reed Length**

Lay the fibre strand on a smooth horizontal platform or floor. Remove any kinks or bends with minimum tension without unduly stretching the fibre strand. Measure the length of the strand from one end to the other with the help of a tape correct to 0.5 cm ( $L$ ).

##### **3.2 Effective Reed Length**

Measure the length of the root ( $L_1$ ) and croppy end portion ( $L_2$ ) correct to 0.5 cm. Determine the effective reed length by the following formula:

$$\text{Effective reed length} = L - (L_1 + L_2)$$

**3.3** Repeat the test with the remaining test specimens and determine the average of all the values.

#### **4 REPORT**



**4.1** The report shall include the following information:

- a) Type of fibre tested;
- b) Average reed length;
- c) Average effective reed length; and
- d) Size of the sample (strands).

**TEXTILES — PHYSICAL METHODS OF TEST FOR  
UNCUT INDIAN JUTE, *MESTA/BIMLI***

**PART 3 ROOT CONTENT**

[ *Second Revision of IS 7032 (Part 3)* ]

**1 SCOPE**

This standard (Part 3) prescribes a method for the determination of root content of Jute, *Mesta/Bimli* fibre strands.

**2 EQUIPMENT**

2.1 The following set of equipment are required:

- a) Weighing balance, and
- b) A pair of scissors.

**3 PROCEDURE**

**3.1 Reed length (L):** Lay the fibre strand on a smooth horizontal platform or floor. Remove any kinks or bends with minimum tension without unduly stretching the fibre strand. Measure the length of the strand/reed from one end to the other with the help of tape or scale correct to 0.5 cm. (minimum 5 readings).

**3.2 Root length:** Measure the length of the bottom root (L<sub>1</sub>) portion of each individual strand/reed correct to 0.5 cm.

3.3 Repeat the test with the remaining test specimens.

**4 CALCULATIONS**

4.1 Calculate the root content of the individual test specimens as follows:

$$\text{Root content} = \frac{L_1}{L} \times 100$$

4.2 Calculate the average of all the values obtained in 4.1.

## **5 REPORT**

**5.1** The report shall include the following information:

- a) Type of fibre tested;
- b) Average root content, percent; and
- c) Size of the sample (strands).

**TEXTILES — PHYSICAL METHODS OF TEST FOR  
UNCUT INDIAN JUTE, *MESTA/BIMLI***

**PART 4 DEFECTS**

[*Second Revision of IS 7032 (Part 4)*]

**1 SCOPE**

**1.1** This standard (Part 4) prescribes a method for the determination of defects (centre root, crop-end, runners and hunka) in the Jute, *Mesta/Bimli* fibre strands.

**2 EQUIPMENT**

**2.1** The following set of equipment are required:

- a) Weighing balance, and
- b) A pair of scissors.

**3 PROCEDURES**

**3.1** Take a test specimen consisting of full-length reeds and determine its mass to an accuracy of 1 g ( $W$ ).

**3.2** Cut the centre-root and crop-end portions and keep them separately. Determine the mass of the centre-root ( $W_1$ ) and crop-end ( $W_2$ ) to an accuracy of 1 g.

**3.3** Separate out the runners from the cut fibres, if any, and determine its mass to an accuracy of 1 g ( $W_3$ ).

**3.4** Remove the hunka from the cut fibres and determine its mass correct to 1 g ( $W_4$ ).

**3.5** Repeat the test with the remaining test specimens.

**4 CALCULATIONS**

**4.1** Calculate the percentage of centre-root, crop-end, runner and hunka of the individual test specimens as follows:

a) Centre-root,  $P_1 = \frac{W_1}{W} \times 100$

b) Crop-end,  $P_2 = \frac{W_2}{W} \times 100$

c) Runner,  $P_3 = \frac{W_3}{W} \times 100$

d) Hunka,  $P_4 = \frac{W_4}{W} \times 100$

**4.2** Determine the percentage of total defects by adding  $P_1$ ,  $P_2$ ,  $P_3$ , and  $P_4$

**4.3** Determine the average of all the values.

## **5 REPORT**

**5.1** The report shall include the following information:

- a) Type of fibre tested;
- b) Average percentage of;
  - 1) centre-root;
  - 2) crop-end;
  - 3) runner; and
  - 4) hunka.
- c) Average total defects; and
- d) Size of the sample (strands).

**TEXTILES — PHYSICAL METHODS OF TEST FOR  
UNCUT INDIAN JUTE, *MESTA/BIMLI***

**PART 5 FOREIGN MATTER**

[ *Second Revision of IS 7032 (Part 5)* ]

**1 SCOPE**

This standard (Part 5) prescribes a method for the determination of foreign matter (dust, mud, moss and stick) of the Jute, *Mesta/Bimli* fibre strands.

**2 EQUIPMENT**

**2.1 Weighing Balance**

**3 PROCEDURES**

**3.1** Take a test specimen and weigh it to an accuracy of 1 g ( $W_1$ ). Beat the fibre strand against a hard surface and shake to remove dust, mud and other foreign matter. Continue beating until the mass becomes reasonably constant. Separate out by hand the moss and sticks, if any, from the strand. Then determine the final mass of the strand to an accuracy of 1 g ( $W_2$ ).

**3.2** Repeat the test with the remaining test specimens.

**4 CALCULATIONS**

**4.1** Calculate the percentage of foreign matter of the individual test specimen as follows:

$$\text{Foreign matter, percent} = \frac{W_1 - W_2}{W_1} \times 100$$

**4.2** Calculate the average of all the values.

**5 REPORT**

**5.1** The report shall include the following information:

- a) Type of fibre tested;
- b) Average amount of foreign matter, percent; and

c) Size of the sample (strands).

*Draft Indian Standard*

**TEXTILES — PHYSICAL METHODS OF TEST FOR  
UNCUT INDIAN JUTE, *MESTA/BIMLI***

**PART 6 BULK DENSITY**

[*Second Revision of IS 7032 (Part 6)*]

**1 SCOPE**

This standard (Part 6) prescribes a method for the determination of bulk density of Jute, *Mesta/Bimli* fibres.

**2 PREPARATION OF TEST SPECIMEN**

**2.1** Take clean portions of 100 mm length at random from the middle region of the reeds (like leaving aside rooty bottom, croppy-end and defects). Adjust the sample 'size' so that the mass of each sample is 40 g. Prepare at least 3 such samples.

**3 APPARATUS**

**3.1 Metallic Plates** — of 100 mm × 25 mm with suitable arrangements for bringing them close by applying pressure in the form of dead weight. An outline sketch of an apparatus suitable for this purpose is given in Fig. 1.

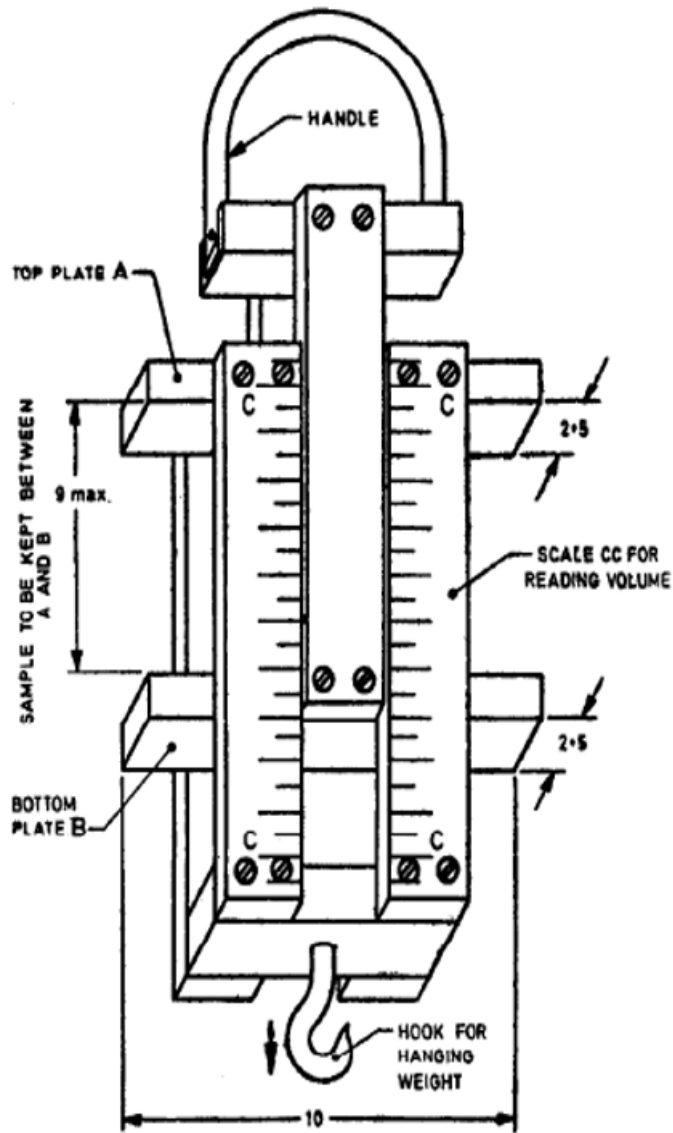

All dimensions are in centimeters.

FIG. 1 BULK DENSITY MEASURING GADGET

### 3.2 Weighing Balance

## 4 PROCEDURE

4.1 Take a sample as laid down in 2.1 and place it in between the two metallic plates keeping the gadget flat on the table. Suspend the instrument from the handle. Apply a load of 10 kg and note down the volume of the fibres from the scale of the instrument.

NOTE — The samples may be tested in the prevailing atmospheric conditions. However, in case of dispute, the sample shall be conditioned and tested in standard atmospheric conditions as specified in 4 of IS 7032 (Part 1).

4.2 Similarly, test the other two test specimens.



## 5 CALCULATIONS

5.1 Calculate the bulk density by the following formula:

$$D = \frac{M}{V}$$

Where

$D$  = bulk density,

$M$  = mass of fibres compressed in g, and

$V$  = volume of fibres under compression in ml.

## 6 REPORT

6.1 The report shall include the following information:

- a) Type of fibre tested;
- b) Number of test specimens tested; and
- c) Bulk density.

# TEXTILES — PHYSICAL METHODS OF TEST FOR UNCUT INDIAN JUTE, *MESTA/BIMLI*

## PART 7 BUNDLE STRENGTH

[ *Second Revision of IS 7032 (Part 7)* ]

### 1 SCOPE

This standard (Part 7) prescribes a method for testing bundle strength of Jute, *Mesta/Bimli* fibres by tensile testing machines, working at constant rate of loading (CRL), constant rate of elongation (CRE) and constant rate of traverse (CRT).

### 2 PRINCIPLE

A bundle of fibres of 1.5 ktex to 3.0 ktex or recommended by the instruction manual of the instrument is gripped between two suitable clamps and their breaking load is determined on tensile testing machines. Then, tenacity is calculated by dividing the breaking load by the mass of the fibres held between the clamps.

### 3 PREPARATION OF TEST SPECIMEN

**3.1** Take a clean portion of 200 mm in length at random from the middle region of the reeds (leaving aside the rooty bottom, cropy end and defects). Cut out sufficient length from each portion to cover fully both clamps. The mass of each portion should be approximately 300 to 600 mg; heavier ones shall be thinned out from the side and to the lighter ones another reed or a portion of a reed shall be added. Make this adjustment simply by feel. Take 5 portions constituting 5 test specimens (bundles).

**3.2** Similarly prepare at least 2 more sets of 5 specimens as in **3.1**.

### 4 TERMINOLOGY

**4.1 Fibre bundle** — A test specimen consisting of a thin layer of parallel fibres having length specified by the instrument manual.

**4.2 Tenacity** — Breaking load of the fibre sample under test divided by the linear density of the unstrained fibre. It is usually expressed in terms gm/tex.

**4.3 Breaking load** — Maximum force recorded when a test specimen ruptures.

**4.3 Gauge length** — The distance between the inner faces of the pair of jaw at the start of the test.

## 5 APPARATUS

**5.1 Testing Machine** — Tensile strength testing machine with a capacity of 100 kgf or a little more working on one of the following principles:

- a) Constant rate of traverse (CRT);
- b) Constant rate of load (CRL); or
- c) Constant rate of extension (CRE).

**5.1.1** The specimens shall break within  $20 \text{ s} \pm 5 \text{ s}$ . In case of constant rate of traverse machine, the time of break shall exceed the inertial period of the instrument. The load range of the machine shall be such that the observed values would be between 10 percent to 90 percent of the full-scale load. The permissible error in the machine at any point in this range shall not exceed  $\pm 1$  percent of the maximum load. The machines shall be provided with the following arrangements:

- a) Two clamps with the following provisions to grip the specimens:
  - 1) Each clamp shall be such that at least 10 mm of fibre length is gripped. There should be no slippage of fibres during the test. To prevent slippage the inside of the clamps should preferably be lined with leather or rubber padding.
  - 2) The clamps shall be capable of being adjusted to 50 mm test length.
- b) A scale or dial for recording the load in kilograms.

NOTE — A suitable instrument developed by ICAR-National Institute of Natural Fibre Engineering and Technology, Kolkata is described in Annex A.

## 6 PROCEDURE

**6.1 Mounting the Test Specimen** — Place the two clamps 50 mm apart. Put the fibre bundle in one of the clamps and tighten it. Straighten the fibres, putting a small tension and tighten it in the other clamp. If the clamps are detachable, these can be taken out of the machine, placed on a platform, separated 50 mm apart and the fibre bundle fixed as above. The clamps can then be inserted into the clamp holders on the machine. The fibre bundle should be parallel to the axis of the machine.

**6.2** With the help of preliminary specimen, set the machine so that the specimen breaks within  $20 \text{ s} \pm 5 \text{ s}$ . In the case of constant rate of traverse type machine set it at a rate of traverse so that the time of break exceeds the inertial period of the instrument.

**6.3** Operate the machine and carry the test to rupture and record the breaking load of the specimen. If the specimen slips in the jaws the test shall be discarded but noted, and another test taken in view thereof.

NOTE — Even if a test value is isolated on account of break near the jaw, the value shall be noted but not taken into account in calculations. If such breaks exceed 10 percent of the number of specimens tested, suitable corrective action on the machine may have to be taken.

**6.4** With a knife or sharp razor blade cut the fibres flush at the inner edges of the two clamps and collect the tufts of fibres thus obtained. Test the other test specimens in similar manner.

**6.4.1** Weigh the broken tufts of fibres for the 5 specimens together.

**6.5** Test at least 3 groups of 5 specimens each in similar manner.

NOTE — Sampling and procedures for testing for measurement of bundle strength by ‘Digital Bundle Strength tester’ are given in Annex A.

## **7 CONDITIONING AND TESTING OF TEST SPECIMENS**

**7.1** All the tests shall be carried out as laid down in 4 of IS 7032 (Part 1).

**7.1.1** In case standard atmospheric conditions are not available, the samples may be conditioned and tested at the prevailing atmospheric conditions and the prevailing relative humidity shall be noted and correction applied for mass and breaking load as given below:

- a) *Correction for mass* — Convert the mass of fibre bundles as obtained in **6.4.1** to equivalent mass at 65% relative humidity. For this purpose, the equilibrium moisture regain for Jute corresponding to prevailing RH, will require to be determined from the regain humidity curve for Jute or by using a suitable moisture regain meter. For example, if the moisture regain at the prevailing RH is R the corrected mass at 12 percent moisture regain corresponding to 65% RH will be given by the formula  $M \times \frac{100+12}{100+R}$ , (12 is the approximate moisture regain of Jute at 65 % relative humidity).
- b) *Correction for breaking load* — Convert the breaking load values obtained in **6.3** for the difference in relative humidity to breaking load at 65 % relative humidity by multiplying with the applicable correction factor as given in Annex B. However, if the relative humidity is between 35 % to 75 %, the correction for breaking load value is small and may be ignored. The corrected values of mass and breaking load shall be used in the formula given in **8.1**.

## 8 CALCULATION

8.1 Calculate the tenacity of the fibre by the following formula:

$$\text{Tenacity (in g/tex), } S = \frac{50 \times T}{M}$$

where

$T$  = sum of the breaking load values of 5 bundles of fibres in kgf; and

$M$  = total mass of all the bundles in milligrams.

NOTE — 50 in tenacity formula has been obtained by multiplying the length by 10. The length indicated in 5.1 [a (2)] is 5 cm.

8.2 Determine the average value of tenacity  $S$  from at least 3 sets of readings.

NOTE — When the difference between any two values of tenacity ( $S$ ) exceeds 15 percent of the mean, another value for  $S$  should be obtained and the average of four readings shall be reported.

## 9 REPORTS

9.1 The report shall include the following information:

- a) Type of fibre tested;
- b) Type of machine;
- c) Number of test specimens tested;
- d) Tenacity;
- e) Breaking load; and
- f) State of test specimen.

**ANNEX A**  
(Clauses 5.1.1 and 6.5)

**NINFET DIGITAL BUNDLE STRENGTH TESTER**

(Mention of the name ‘NINFET Digital Bundle Strength Tester’ of a specific (or proprietary), instrument is not intended to promote, or give preference to the use of this instrument over others not mentioned.)

**A-1 DESCRIPTION OF THE INSTRUMENT**

This instrument measures the bundle strength of Jute, *Mesta/Bimli* fibres. It works on the principle of constant rate of loading (CRL). The length of the fibre bundle of 12.5 cm and weight of 300 mg to 600 mg is gripped between two suitable clamps/jaws and tenacity (g/tex) is measured.

NOTE — This testing machine consists of permanent magnet DC motor, ramp generator circuit, load cell and latch circuit. Permanent magnet DC motor operates from a ramp generator circuit, which produces a linearly increasing current with respect to time having a constant slope. The schematic diagram of the bundle strength tester is shown in Fig. 1. The torque induced in the motor will be thus proportional to the current taken by the motor. The ramp generator will thus induce a linearly increasing torque to the motor, which will be fed to the arm. This applied torque will be multiplied by the ratio of the lengths from the pivot to the motor end with the length from pivot to the fibre-holding end. So, the induced force on the fibre bundle will be increased slowly but at a constant rate. When the amount of the induced force will be just greater than the breaking strength of the fibre bundle under test, the fibre bundle will be broken off. At the time of breaking off the fibre bundle, a limit switch will turn off the ramp generator circuit and the current will thus be cut off. At that instant, the value of the current will be latched and the latch circuit will store this value. This stored value of the current taken by the motor will indicate the breaking strength of the fibre to some other scale.

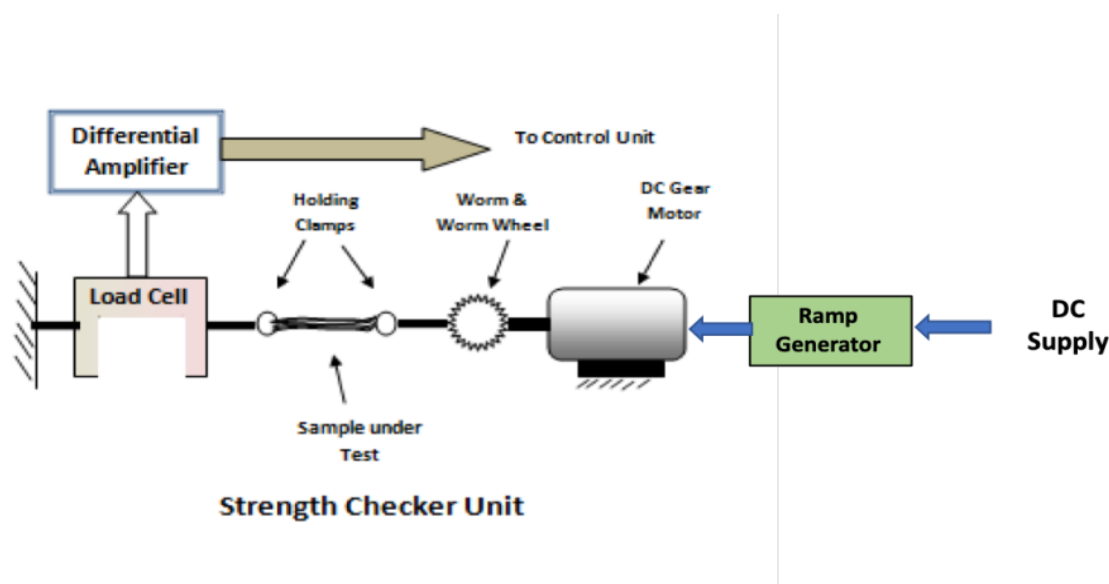

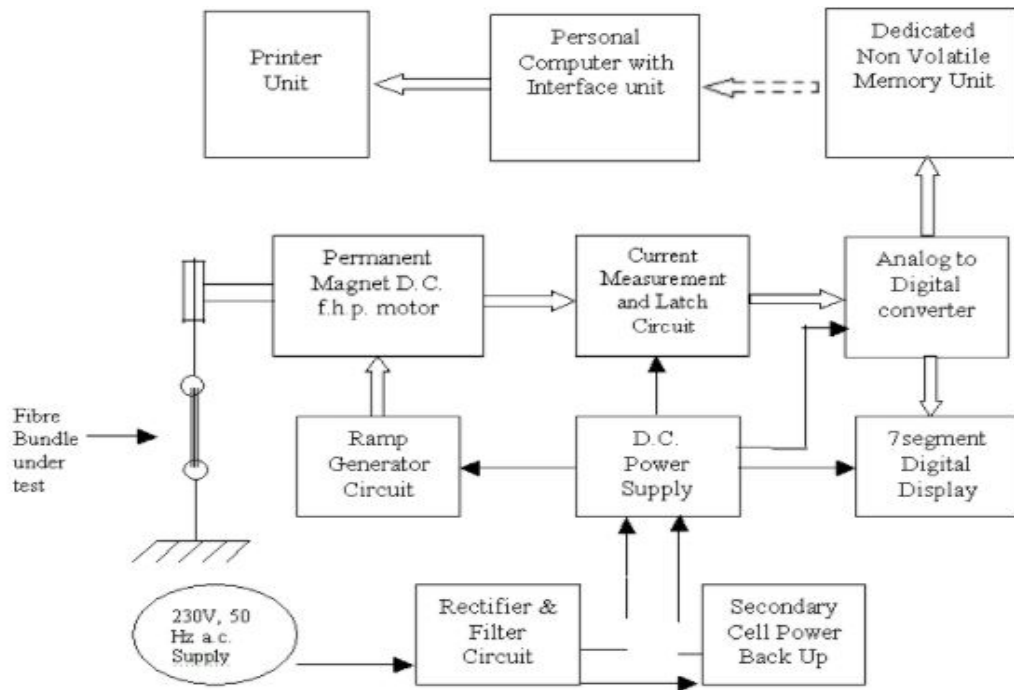

FIG. 1 THE SCHEMATIC DIAGRAM OF THE BUNDLE STRENGTH TESTER

## A-2 APPARATUS

**A-2.1 Testing Machine** – Bundle strength testing instrument with a load cell capacity of 200 kgf or a little more working on Constant rate of load (CRL) can be used. The instrument employed on aforesaid principles is automatic bundle strength tester. Automatic bundle strength tester shall have fibre clamp holder (jaws) as an integral part of the instrument. The permissible resolution in the instruments load cell at any point of measurement shall not be more than 0.1 kg.

The instrument shall have the following arrangements:

- The instrument shall be provided with means for indicating or recording both forces applied and tenacity of test specimen after rupture of fibre.
- Knob or weight measurement setup to vary the weight of bundle shall be provided in the instrument.
- Specimens shall be placed parallel into the jaw. The Jaw shall hold fibre firmly and distance between two jaws shall not be more than 50 mm. To restrict excess movement of jaw, limit switch shall be provided.
- The length of jaw shall not be more than 50 mm and width shall be 10 mm and to prevent fibre slippage inside the jaw/ clamps, holding unit must be lined with leather or rubber padding
- The instrument shall be capable of constant rate of load of 3 kg/second with an accuracy of 10 percent.
- The uncertainty of the instrument shall not be exceed  $\pm 0.075$  gm/tex

**A-2.2 Balance** – balance with 10 to 220 mg with capable of weighing the specimen to an accuracy of  $\pm 5$  mg.

**A-2.3 Device for Fibre Cutting** — fibre cutter or a pair of scissors.

### **A-3 PREPARATION OF TEST SPECIMEN**

A clean portion of 200 mm in length shall be taken at random from the middle region of the reeds (leaving aside the rooty bottom, crappy end and defects). Sufficient length from each portion is cut out to cover fully both the clamps. The mass of each portion shall be approximately 300 to 600 mg; heavier ones shall be thinned out from the side and to the lighter ones shall be added from another reed or a portion of a reed. This adjustment shall be made simply by feel. Take 2 portions constituting 5 test specimens (bundles).

### **A-4 PROCEDURE**

Make the necessary preliminary adjustments appropriate to the instruments used as per technical manual.

- a) Weight the specimen to be tested and place centrally in longitudinal in the jaws/clamps.
- b) Set the weight of specimen using knob provided on the instrument and break the fibre.
- c) Specimen must be break within 10 mm to 20 mm of recommended distance.
- d) There shall be no slippage of fibres from the jaw or clamp during the test. The bundle shall be break in the middle of the region of fibre.

Note — If the specimen slips in the jaws, the test shall be discarded and new specimen shall be used for repeating the experiment.

- e) The instrument shall be operated as per the procedure given in technical manual of the instrument and the bundle strength shall be recorded accordingly.
- f) At least 2 groups of five specimens shall be tested in similar manner, if the difference between tenacity exceeds 15 percent of the mean, another one trail may be conducted and shall be reported.

### **A-5 OPERATION OF THE INSTRUMENT**

- a) Prepare the sample as per standard procedure and weight it before placing the specimen in the jaw/clamps.
- b) Enter the weight of specimen using knob provided on the instrument.
- c) Then Press the “TEST” button for breaking of fibre.

### **A-5 CONDITIONING AND TESTING OF TEST SPECIMENS**

The test shall be carried out in prevailing atmospheric conditions. However, in case of dispute, the conditioning and testing shall be carried out at standard atmospheric conditions of 65 %  $\pm$  2 % relative humidity and 27 °C  $\pm$  2 °C temperature (see IS 196 and IS 6359).

### **A-6 CALIBRATION OF THE INSTRUMENT**



The correction factors shall be considered for calculation of strength. The load cell of the instrument must be calibrated by NABL accredited laboratory. The length and weight of the specimen required for calibration of digital bundle strength tester shall be same that of mechanical bundle strength tester. Conduct at least 20 measurements in both the instruments and the correction factor may be calculated by the following equation:

$$\text{Correction factor} = \frac{\text{Bundle strength value in mechanical instrument (g/tex)}}{\text{Bundle strength value in digital instrument (g/tex)}}$$

It shall be made sure that necessary adjustments are appropriate to instruments. The instrument display shows SET LOAD FACTOR option when menu button is pressed long. The load factor is set by pressing TARE and TEST button for ascending and descending the value (the default stored in the instrument is 1). The load factors would be stored after long press of MENU button.

**ANNEX B**  
[Clause 7.1.1 (b)]

**FACTORS FOR CORRECTING BUNDLE STRENGTH OF JUTE  
AT DIFFERENT RELATIVE HUMIDITIES (OR MOISTURE  
REGAINS) TO STRENGTH AT 65 % RH (12.4  
PERCENT MOISTURE REGAIN)**

<i>Equilibrium Related Humidity, Percent</i>	<i>Moisture Regain Percent</i>	<i>Correction Factor (Multiply by)</i>
10	3.0	1.35
15	3.9	1.21
20	4.8	1.13
25	5.7	1.08
30	6.5	1.05
35	7.0	1.03
40	8.0	1.01
45	8.7	1.00
50	9.5	
55	10.5	
60	11.5	
65	12.4	
70	13.5	1.01
72	14.0	1.02
75	15.0	1.03
80	16.5	1.06
85	18.8	1.09
90	22.0	1.15
95	26.8	1.24

NOTE — No correction is necessary when the relative humidity of the testing atmosphere ranges between 35 and 75 percent.

# TEXTILES — PHYSICAL METHODS OF TEST FOR UNCUT INDIAN JUTE, *MESTA/BIMLI*

## PART 8 FINENESS

[*Second Revision of IS 7032 (Part 8)*]

### 1 SCOPE

**1.1** This standard (Part 8) prescribes a method for the determination of fineness of Jute, *Mesta/Bimli* fibres by air flow method.

### 2 PRINCIPLE

**2.1** A specified mass of fibres is compressed to a constant volume in a cylindrical chamber with open ends to which a flowmeter and a manometer are connected. A regulated current of air is then passed through the compressed fibres and the average fibre fineness read from the scale.

### 3 TERMINOLOGY

**3.1 Linear Density** — Mass per unit length; the quotient obtained by dividing the mass of the fibre by its length.

**3.2 Fineness** — It is a measure of diameter or thickness of the fibre. Fineness is usually expressed by linear density or mass per unit length in tex (gm/km) unit.

**3.3 Operating pressure** — The pressure required to create the required pressure difference across the orifice. It is expressed in kPa.

### 4 APPARATUS

**4.1 Air Flow Apparatus** — It shall consist of the following principal parts:

- a) *Constant Volume Chamber* — for taking a known mass of fibres and compressing it to a fixed known volume. It generally comprises:
  - 1) a plug cell into which the fibres are packed,
  - 2) a plunger which compresses the fibres, and
  - 3) a screw cap which clamps the plunger to the base.
- b) *Means for Air Regulation* — for regulating and controlling the flow of air through or air pressure difference across the specimen. It shall give sufficiently fine control of air

supply so that the level of the flowmeter or manometer may be quickly adjusted to the working valve.

- c) *Means for Producing Air Flow* — Capable of producing the required air pressure applied to the specimen or the required pressure difference across the specimen.
- d) *Means for Measuring the Resistance to Air Flow or the Air Pressure Difference Across the Specimen* — The combination of manometer for maintaining the air pressure applied to the specimen and a flowmeter for indicating the rate of air flow through the specimen may be used. Flowmeter or manometer shall be calibrated to directly read the fineness in tex or denier.

NOTE — Three suitable instruments developed by: (a) Ahmedabad Textile Industry's Research Association, Ahmedabad (modified by Indian Jute Industries Research Association, Kolkata); (b) ICAR-Jute Technological Research Laboratories, Kolkata; and ICAR-National Institute of Natural Fibre Engineering and Technology, Kolkata are described in Annexes A, B and C respectively.

**4.2 Balance** — Capable of weighing the specimen to an accuracy of  $\pm 5$  mg.

**4.3 Device for Fibre Cutting** — fibre cutter or a pair of scissors.

## 5 PREPARATION OF TEST SPECIMEN

**5.1** Take a suitable portion at random from the middle regions (leaving aside the rooty bottom and under-retted crop ends) of several reeds, covering the full range of the sample. Clean each portion so as to free it from barky, specky and knotty spots, hard gummy fibres as well as other extraneous materials. If necessary, the cut fibre reeds shall be lightly struck against a hard surface to shake off the adherent dirt and dust. Cut the fibre bundles to a specified length and take the mass of the fibres as required by the instrument used (*see Annexes A, B and C*).

## 6 PROCEDURE

**6.0** Make the necessary preliminary adjustments appropriate to the instrument used. Ensure that the meniscus of the manometer is at the zero mark.

**6.1** Place the test specimen in the fibre compression cylinder, taking care that all the fibres are placed inside. Adjust the machine as recommended by the instruction manual of the instrument (*see Annexes A, B and C*).

**6.2** Cause the air to flow through the specimen and read the air flow or the difference in pressures on the scale to an accuracy of half a division of the scale.

**6.3** Remove the test specimen from the fibre compression cylinder and take one or two more readings on the same specimen as recommended by the instruction manual of the instrument.

**6.4** Take the other test specimens and determine the test values in the manner set out in **6.1** to **6.3**.

## **7 CALCULATIONS**

**7.1** Calculate the average of all the values taken for all test specimens.

## **8 REPORT**

**8.1** The report shall include the following information:

- a) The instrument used;
- b) Number of test specimens; and
- c) Fibre fineness in tex, or denier.

## **ANNEX A**

*(Clauses 4.1, 5.1 and 6.1)*

### **IJIRA JUTE FIBRE FINENESS TESTER**

(Mention of the name 'IJIRA Jute Fibre Fineness Tester' of a specific (or proprietary), instrument is not intended to promote, or give preference to the use of this instrument over others not mentioned.)

#### **A-1 DESCRIPTION OF THE INSTRUMENT**

**A-1.1** A working sketch is shown in Fig. 1. A rubber bulb (6) which when squeezed, pumps air into a tank (8), equipped with a loosely fitting float (7) which can rise to the top of the tank. As the float descends, it forces air through the outlet of the apparatus if the rate of flow is sufficiently small, sensibly constant air pressure can be secured for a sufficiently long interval. The air outlet in the needle valve (14) is connected in series with the sample chamber (11). The cylindrical sample chamber is filled with a weighed amount of the opened sample under investigation, and closed by a perforated piston (10) which compresses the plug to the same dimensions each time. After passing through the plug, the air escapes into the atmosphere. The junction of the needle valve and the sample chamber is connected to the reservoir manometer (4). The measuring limb of this reservoir consists of three parts, namely, a first vertical section, which is always filled by the manometric liquid when testing any sample within the range of the instrument; an inclined section which is directly calibrated in denier, and a third vertical section which serves to monitor the constancy of total pressure. The entire assembly is mounted on a board provided with levelling screws.

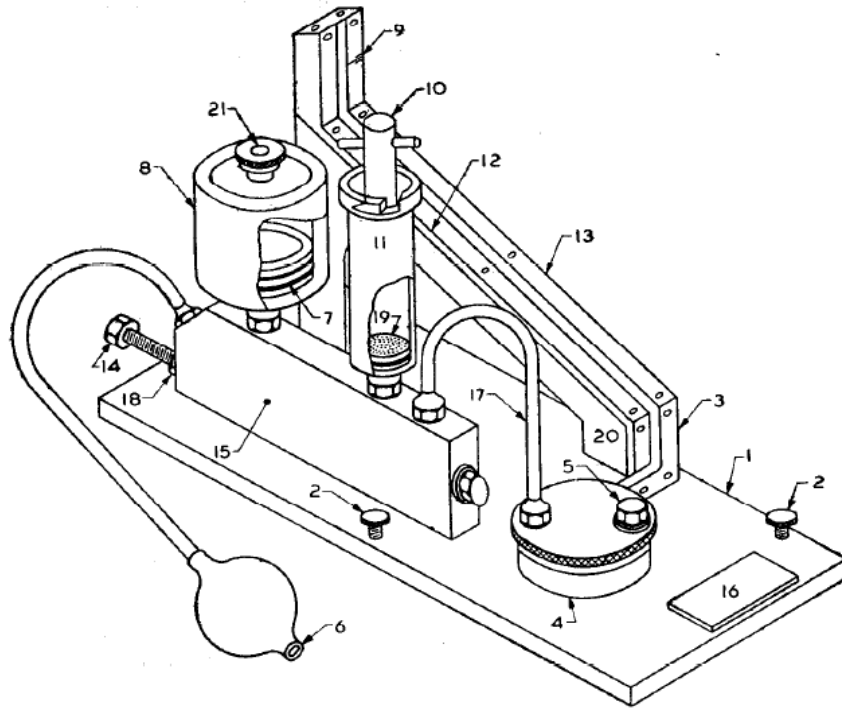

- |   |                                   |
|---|-----------------------------------|
| 1. Thermosetting laminate mounted board | 11. Sample chamber                |
| 2. Levelling screws                     | 12. cm scale                      |
| 3. Reference mark for liquid            | 13. Denier scale                  |
| 4. Reservoir for manometric liquid      | 14. Needle valve                  |
| 5. Reservoir plug                       | 15. Distributor                   |
| 6. Aspirator bulb                       | 16. Name plate                    |
| 7. Float                                | 17. Air pressure maintaining tube |
| 8. Air tank                             | 18. Check nut                     |
| 9. Reference mark for total pressure    | 19. Perforated disc               |
| 10. Piston                              | 20. All gradient stand            |
|   | 21. Air filter                    |

FIG. 1 IJIRA FIBRE FINENESS TESTER

**A-1.1.1** The calibrated section of the manometer is inclined (horizontal gradient 1 in 5) in order to increase the sensitivity and spread out the scale.

## A-2 OPERATING PROCEDURE

**A-2.1** Level the instrument with the help of the levelling screws and a spirit level.

**A-2.2** Collect about 40 g of raw Jute after proper sampling. Cut the fibre to approximately 1 cm pieces. Mix the cut fibres thoroughly and tease out by hand.

**A-2.3** Divide the cut sample into 3 sub-samples. Weigh one specimen of 8.65 g from each sub-sample.

**A-2.4** Pack the weighed specimens into the sample chamber and close the chamber by piston (10),

**A-2.5** Squeeze the aspirator bulb (6) a number of times as the float in the tank (8) rises to the top. Stop squeezing and the float will start descending. Observe the position of manometer liquid. At a certain point the manometer reading will remain steady for a while. Note the denier reading corresponding to this position of the manometer liquid.

**A-2.6** Remove the specimen, fluff it out and repeat for a repeat test.

**A-2.7** Repeat as in **A-2.6**. Altogether take 3 readings for each specimen.

**A-2.8** Repeat the, test for the other two specimens as in **A-2.3** to **A-2.7**.

**A-2.9** Find the average of the 9 readings.

### **A-3 CHECKING**

**A-3.1** In order to check from time to time that the instrument is performing satisfactorily, readings should be taken on the calibration sample provided.

## **ANNEX B**

*(Clauses 4.1, 5.1 and 6.1)*

### **JTRL JUTE FIBRE FINENESS TESTER**

(Mention of the name 'JTRL Jute Fibre Fineness Tester' of a specific (or proprietary) instrument is not intended to promote, or give preference to the use of that instrument over others not mentioned.)

#### **B-1 DESCRIPTION OF THE INSTRUMENT**

**B-1.1 Air Flow Production Arrangement** — The aspirator (*I* in Fig. 2) is a wide flat tank T, of 400 cm<sup>2</sup> area with a narrow outlet *O*<sub>1</sub> of 6 mm diameter. The tank is raised to suitable height (40 to 50 cm) by a stand the outlet at *O*<sub>2</sub> being extended below by a rubber tube for a higher water head without having to handle a large quantity of water.

**B-1.1.1** To maintain a constant water head, the top level drop has been neutralized by pulling down the end of the outlet rubber tube to some extent, such that the difference in water head (*H*)

between the water level in the tank and the tip of the outlet  $O_2$  remains constant. This has been achieved by a simple device. The end  $O_2$  of the outlet rubber tube is attached to the top opening of the receiver  $T_2$  hung from a spring. The spring is so adjusted that the weight of liquid being drained into the receiver is sufficient to extend the spring by an amount equal to the drop in the liquid level in the  $T_1$ . The constant level difference thus maintained ensures constant rate of flow.

**B-1.1.2** For refilling the tank  $T_1$  the receiver  $T_2$  is hung upside down from a hook  $N$  above the tank  $T_1$  into which the receiver empties itself through the same rubber tube  $E$ . The tank  $T_1$  has two openings,  $I_1$  and  $I_2$  at the top,  $I_1$  having a tap, and one outlet with a tap at the bottom. The inlet tube  $I_2$  is connected to the regulating valve  $Y$  and the other parts of the instrument, through it air is sucked in as water flows out of the tank. The tap  $I_1$  provides an opening to the atmosphere during refilling. In the receiver  $T_2$  also the side opening  $B$  maintains a connection between the inside and the outside atmosphere. The specifications of the flow system are such that a maximum flow rate of about 15 ml per second can be mentioned for 25 seconds.

**B-1.2 Flow Gauge** — The flow gauge ( $II$  in Fig. 2) is essentially a manometer ( $F_1, F_2$ ), attached to the two ends of a glass wool plug or an equivalent glass or brass capillary tube  $W$  in a glass tube. For a particular flow rate through the plug, a difference of pressure develops between the ends of the plug and is indicated in this manometer. This manometer is calibrated in terms of flow rate, since pressure difference is proportional to the flow rate. The packing of the glass wool plug may be altered for different ranges of flow rate.

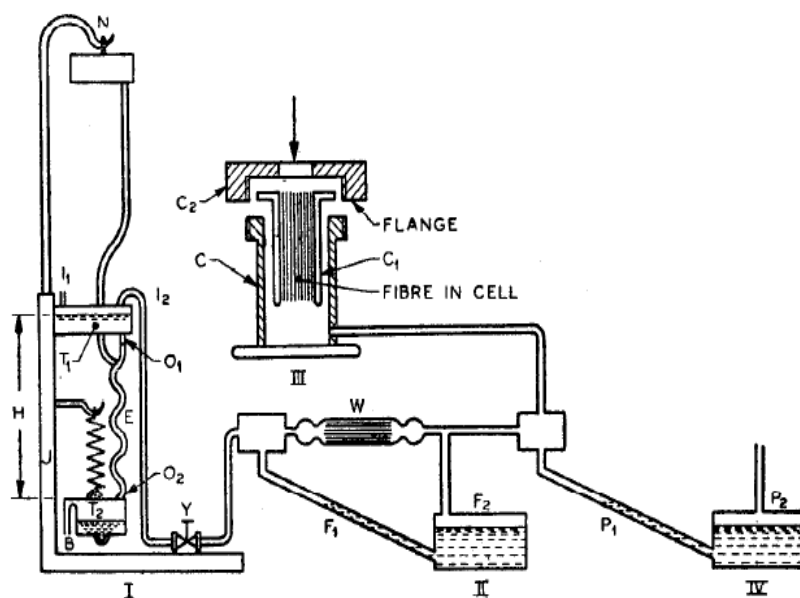

Keys

<i>I</i>	Aspirator	$I_1$	Tap
<i>II</i>	Flowmeter	$I_2$	Inlet tube
<i>III</i>	Plug Chamber	$J$	Stand
<i>IV</i>	Manometer	$N$	Hood
$B$	Side opening	$O_1$	Narrow outlet



$C$	Chamber	$O_2$	End of the rubber tube
$C_1$	Plug cell	$P_1, P_2$	Pressure gauge
$C_2$	Centre open screw cap	$T_1$	Tank
$E$	Rubber tube	$T_2$	Receiver
$F_1, F_2$	Manometer	$W$	Glass wool plug
$H$	Water head	$Y$	Regulating valve

FIG. 2 INSTRUMENT FOR FIBRE FINENESS DETERMINATION

**B-1.2.1** To increase the sensitivity of the flow gauge manometer, the area of limb  $F_2$  is made much larger than that of the other, such that the depression in the wider limb is negligible in comparison to the elevation of the liquid in the narrow limb, and further, the narrow limb is kept inclined at  $60^\circ$  to the vertical. A sliding scale is placed beside the narrow limb. The zero of the scale is made to coincide with the liquid meniscus before starting the test. If the meniscus level falls below a mark, some liquid may be added into the wider limb. The glass wool plug is so adjusted that the flow gauge manometer reading is changed from 0 to 26 cm with increase in flow rate from 0 to 15 ml per second.

**B-1.3** Fibre Plug and the Chamber - A plug is formed of parallel fibre bundles. Such a plug is introduced longitudinally into a cylindrical cell  $C_1$  of 1.25 cm diameter and 5 cm length (*III* in Fig. 2). At one end, the cell has a flange which can be pressed air-tight on the rubber ring over the rim of a wider chamber  $C$  by a centre open screw cap 2.

**B-1.3.1** The chamber is thus open to the atmosphere at the top, and a small tube at the bottom connects the chamber to the manometer and the other parts of the instrument.

**B-1.4 Pressure Gauge** — The pressure gauge  $P_1, P_2$  (*IV* in Fig. 2) is a manometer used for registering the difference of pressure between the two ends of the fibre plug. One end of the manometer as well as the fibre plug is open to the atmosphere. The design of the gauge is exactly similar to that of the manometer used for the flow gauge. The zero of the scale is always set at the liquid meniscus before the experiment is started.

## B-2 FIBRE CUTTER

**B-2.1** For a 5 cm plug cell, the fibre bundle shall be cut to 5 cm length. Fibre cutter (Fig. 3) consists of a channel of rectangular cross section with a closely fitting plunger both cut exactly to 5 cm length. The fibre is placed longitudinally in the channel with ends projecting on both sides. The plunger is then pressed by a crew, from the top. The projecting ends of the fibres are then cut flush with the channel ends by a chisel and hammer. The rotatable rectangular frame through which the crew works can be turned aside when the fibre is put in the channel. The plunger is provided with a projection (not shown in Fig. 3) across the length to prevent tilting.

## B-3 OPERATION OF THE INSTRUMENT

**B-3.1** A group of raw Jute fibre samples is cut to 5 cm length by the cutter and exactly 3 g are weighed out of it to form the test bundle. This mass is found suitable for the size of the plug cell used and is also specific for a particular calibration. The bundle is wrapped tightly in a paper strip and introduced into the plug cell  $C_1$ . The paper is then taken out or torn off by pushing the bundle gently either way, keeping the fibre ends flush with the cell ends. The cell is then fitted air-tight onto the chamber  $C$ .

**B-3.1.1** The tank  $T_1$  is filled with water and the top tap  $I_1$  is closed. With the receiver on the spring  $S$ , the outlet tap  $O_1$ , is opened. The regulating valve  $Y$  is then manipulated to attain a fixed difference of pressure indicated on the pressure gauge. Immediately the flow gauge reading is taken.

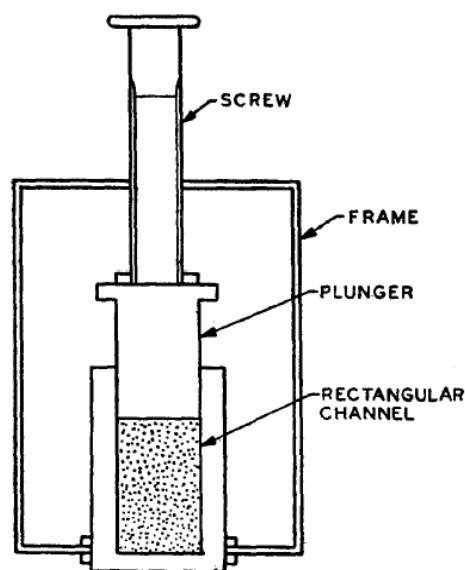

FIG. 3 FIBRE CUTTER

## **B-4 CALIBRATION OF THE INSTRUMENT**

### **B-4.1 Calibration of the Pressure Gauge Manometer**

**B-4.1.1** The fibre plug chamber  $C$  is disconnected and the instrument connected to a vertically mounted U-tube manometer through the leg of a T-tube. One end of the head piece of the T-tube is connected to the U-tube manometer and the other end closed air-tight by means of a screw clip on a rubber tubing.

**B-4.1.2** The water aspiration system is replaced by a suction pump which is connected to the regulating valve  $Y$ . The suction pump is run on and the regulating valve  $Y$  opened slowly to obtain a steady pressure difference in the U-tube manometer. The two liquid columns in the U-tube may be made level again by letting in air through the screw clip on the T-tube.

**B-4.1.3** The steady pressure difference in the U-tube manometer is 9 cm with a manometric liquid (kerosine oil) of specific gravity 0.82. The corresponding pressure gauge reading on the instrument is then marked on a scale placed beside it. For subsequent readings of the flow gauge, the air suction through the valve Y should be controlled so as to give this particular valve of steady pressure on the pressure gauge manometer of the instrument.

#### **B-4.2 Calibration of the Flow Gauge Manometer**

**B-4.2.1** Take a vertically mounted rotameter (a flowmeter having a rotating indicator of air-flow) and connect a rubber tubing at the lower end. Clamp on the rubber tubing a screw clip to regulate air flow through the rotameter.

**B-4.2.2** Disconnect the U-tube manometer and connect the upper end of the rotameter to this point. Run on the suction pump. Adjust the control valve Y and the screw clip of the rubber tubing attached to the rotameter alternately so as to have different flow rates at the particular steady pressure indicated by the pressure gauge manometer of the instrument (corresponding to a pressure head of 9 cm in the U-tube manometer referred to).

**B-4.2.3** Note down the rate of air flow in the rotameter, and mark this flow on the scale beside the flow gauge manometer of the instrument. A number of flow rates all at the steady pressure difference, are thus marked on the flow gauge scale. A calibration curve is drawn relating flow rates (ml/s) and scale length (cm) of the flow gauge. This calibration curve is used to find out the different 'tex' values corresponding to the different flow rates by using the formula,  $\text{tex} = 0.283 \times \text{flow in ml/s}$ . The flow gauge scale is then calibrated directly in terms of tex values.

#### **B-5 SENSITIVITY OF THE INSTRUMENT**

**B-5.1** Since both the pressure and the flow gauges are sensitive enough to detect a change of 1 mm in reading, the approximately error of observation is not likely to exceed 2 percent, when the pressure gauge stands at 18.0 cm and the flow gauge between 6.0 and 26.0 cm. Considering the variation within a sample, this order of sensitivity seems to be sufficient for textile fibres. A 3-g bundle may be made to represent as many regions as possible, to minimize the variation between readings.

**ANNEX C**  
(Clauses 4.1, 5.1 and 6.1)

**NINFET DIGITAL JUTE FIBRE FINENESS TESTER**

(Mention of the name ‘NINFET Digital Jute Fibre Fineness Tester’ of a specific (or proprietary), instrument is not intended to promote, or give preference to the use of this instrument over others not mentioned.)

**C-1 DESCRIPTION OF THE INSTRUMENT**

This instrument measures fineness of Jute, *Mesta/Bimli* fibres by air flow method. The fineness tester works on the principle of pressure difference across the specimen. A specified mass of fibres is compressed to a constant volume in a cylindrical chamber with open ends to which pressure sensors are deployed to measure difference pressures.

The instrument is comprised of air pump, reservoir, pressure sensors and cylindrical plug cell. The line diagram of the instrument is shown in the Fig. 4. The air pump supplies air to plug cell through an air reservoir which provides a stable flow of the air at constant pressure. Using pressure sensors, the pressure is sensed and maintained constant. The pump is run by the triac set using a relay to maintain a constant pressure through the fibre sample under test and an orifice placed in the air flow channel. The difference of pressure across the orifice is measured by using other two pressure sensors and from this value; the flow of air is calculated and displayed in segment display. At the time of measurement of Jute sample, the pressure shall be adjusted by knob provided in the machine. After that, press a ‘TEST’ button and eventually, the display shows the fineness of the test fibre in tex.

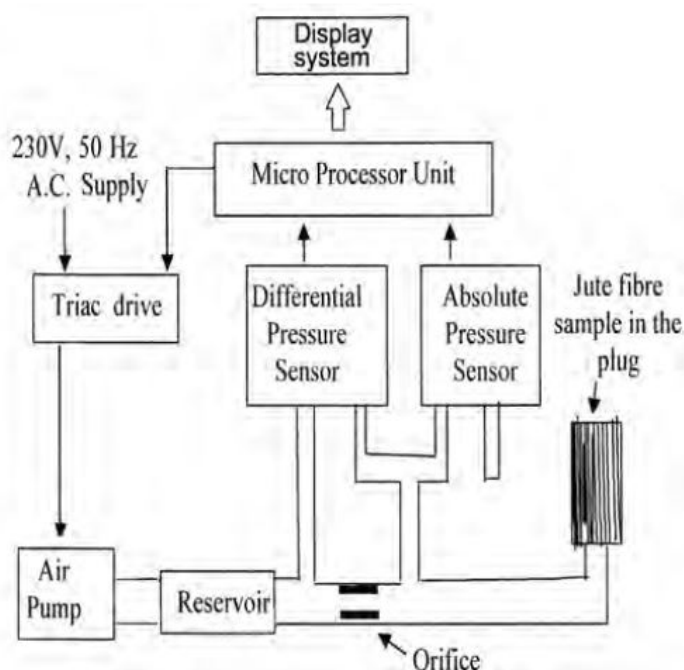

FIG. 4 LINE DIAGRAM OF THE INSTRUMENT

## C-2 APPARATUS

C-2.1 The digital fineness tester shall consist of the following components:

- a) **Air pump** — to provide prerequisite air pressure for the system. The air pump shall be able to develop 1.5 kPa air pressure without fluctuating.
- b) **Reservoir** — provide a stable flow of air at constant pressure and shall be capable of supplying required air pressure to the specimen or the required pressure difference across the specimen.
- c) **Constant volume chamber** — for taking a known mass of fibres and compressing it to a fixed known volume. It generally comprises:
  - 1) a plug cell into which the fibres are packed,
  - 2) a plunger which compresses the fibres, and
  - 3) a screw cap which clamps the plunger to the base.

The fibre plug cell in which specimen placed shall have cylindrical in shape with internal diameter of 12.5 mm and length of about 50 mm.

- d) **Pressure sensors** — to sense pressure and maintain constant pressure in the system. The pressure sensor shall be able to measure the difference across the orifice in the range of -2 kPa to +10 kPa).
- e) **Pressure adjustment** — potentiometer type pressure adjusting or pressure adjustments switch to maintain required pressure of the system.
- f) **Orifice** — the orifice with diameter of 5 mm shall be provided in the instrument to maintain pressure difference across the orifice.

C-2.2 **Balance** — Balance with 10 mg to 220 mg with capable of weighing the specimen to an accuracy of  $\pm 5$  mg.

C-2.3 **Device for fibre cutting** — Fibre cutter or a pair of scissors.

## C-3 OPERATION OF THE INSTRUMENT

- a) The sample shall be prepared as per procedure mentioned in C-4. Then sample shall be introduced into plug cell by wrapping with paper strip. The paper then taken out or torn off by pushing the bundle gently either way, keeping the fibre ends flush with the cell ends.
- b) The specimen shall be placed in fibre plug cell and the standard pressure for Jute fibre may be adjusted (0.72 kPa) by knob provided in the instrument.

- c) Press “Test” button for measuring fineness of fibre.

#### **C-4 PREPARATION OF TEST SPECIMEN**

Fibres of 100 mm length are shall be taken at random from the middle regions (leaving aside the rooty bottom and under-retted crop ends) of several reeds, covering the full range of the sample. The fibre portion is cleaned to free it from barky, specky and knotty spots, hard gummy fibres and dust. Combing is not recommended for Jute fibre. After cleaning, the fibres are cut to a length of 5 cm and bundle shall be weighed with electronic weighing balance having an accuracy of  $\pm 5$  mg. The weight of the fibre shall not be more than 3.0 g.

#### **C-5 Bundle insertion in Fibre plug cell.**

The weighed bundle shall be placed diagonally on a piece of paper, wrap tightly and insert into the cylindrical plug cell. The paper shall be taken out by pushing the bundle in plug cell leaving the fibre end flush with the cell ends. Then, plug cell shall be fitted to fibre plug.

#### **C-6 PROCEDURE**

- i) It shall be made in such a way that the necessary adjustments are appropriate to instruments particularly about system pressure. If system pressure is fluctuating, the required pressure shall be set by operating system for 5 min.
- ii) The specimen shall be placed in fibre plug cell and the standard operating pressure for Jute fibre may be adjusted ( $0.72 \pm 0.1$  kPa) by knob and note down the fineness of fibre.
- iii) Repeat the procedure and take 3 readings for each specimen and repeat the other two specimens.
- iv) Find the average of the nine readings.

#### **C-7 SENSITIVITY OF INSTRUMENT**

The sensitivity of the instrument shall not be more than 2 percent. The instrument shall be calibrated at least once in a year. If the instrument provides sensitivity more than 2 per cent, report it in final report.

#### **C-8 CALIBRATION OF DIGITAL FINENESS METER**

The length and weight of the specimen shall be same that of specimen required for mechanical fineness instrument. The fineness of fibre may be measured in a digital instrument and mechanical instrument and correction factor may be calculated by dividing value of digital instrument from value of mechanical instrument.

Instrument display shows set factor option while pressing long the both ‘START’ and ‘TEST’ button simultaneously. The correction factor shall be set either by ‘START’ button or ‘TEST’ Button. Correction value can be increased by pressing START button and decreased by pressing ‘TEST’ Button. After setting the correction factor, both the buttons shall be pressed for storing the value.

# **TEXTILES — PHYSICAL METHODS OF TEST FOR UNCUT INDIAN JUTE, *MESTA/BIMLI***

## **PART 9 COLOUR**

### **1 SCOPE**

This standard prescribes a method for measuring colour of Jute, *Mesta/Bimli* fibres by reflectance photometer.

### **2 PRINCIPLE**

The instrument is based on the principle of measuring the optical reflectance (or reflectivity) of objects, i.e., the fraction of the incident optical power which is reflected.

### **3 APPARATUS**

Photo-electric Sensor shall consist primarily of an emitter for emitting light and a receiver for receiving light.

NOTE — One suitable instrument developed by ICAR-National Institute of Natural Fibre Engineering and Technology, Kolkata is described in Annex A.

### **4 PREPARATION OF TEST SPECIMENS**

A minimum 10 full-length reeds shall be taken from the fibre reed randomly from the representative sample. The reeds shall be cleaned and made free from dust and dirt. The sample portion shall be placed on the platform and locked. Manually cleaning is recommended.

### **5 CONDITIONING AND TESTING OF TEST SPECIMENS**

The test shall be carried out in prevailing atmospheric conditions. However, in case of dispute, the conditioning and testing shall be carried out at standard atmospheric conditions of 65 %  $\pm$  2 % relative humidity and 27 °C  $\pm$  2 °C temperature (see IS 196 and IS 6359).

### **6 PROCEDURE**

Ensure the instrument's proper functioning and calibrate it. Securely place the reed portion of the sample on the platform. Position a colour meter on the fibre-containing platform. Check the colour at three reed positions (top, middle, and lower), taking three readings at each location. Consider the average value of the nine readings for evaluation.

### **7 TEST REPORT**

The report shall include the following information:

- a) The instrument used;

- b) Number of test specimens;
- c) Colour value; and
- d) Type of fibre tested.

## ANNEX A (Clause 3)

### NINFET COLOUR AND LUSTRE TESTER

(Mention of the name 'NINFET Colour and lustre meter' of a specific (or proprietary), instrument is not intended to promote, or give preference to the use of this instrument over others not mentioned.)

#### 1 PRINCIPLE

The colour and lustre meter works on the principle of reflectance photometer. The sample to be measured shall be positioned in the wooden platform on which colour meter placed.

#### 2 APPARATUS

**2.1** Photo-electric Sensor shall consist primarily of an emitter for emitting light and a receiver for receiving light. The electronic version of the colour meter shall consist of the following components:

- a) **Photo-electric sensor** — Photo-electric Sensor shall consist primarily of an Emitter for emitting light and a Receiver for receiving light. Sensor must be located at 45° for better reflection and emission of light. Four LED strip light bulbs shall be equipped for light source. For colour measurement, two PIN photodiode sensor (BPW34) must be used.
- b) **Area of light falling**—The area of light impinging shall not be more than 250 mm<sup>2</sup>.
- c) **Wood platform** — The length and width of wood platform shall be more than the length and width of colour meter. The colour of wood platform shall be black. It shall have lock arrangement for better holding of fibre.

**2.1.1 Accuracy** — Uncertainty of the digital colour meter shall not be more than 0.05 percent.

#### 2.2 Description

It consists of incandescent light source, sensor, display and wooden platform to place the sample. In this instrument, incandescent source of light and light dependent resistor are used to accept the reflected light from the sample under test. The instrument has three high brightness LED at angle of 45° to horizontal to provide required illumination on the object. Array of silicon PIN photodiode sensors (BPW34) (4 No's), of which three are placed exactly in the centre for colour measurement and one at 45° to the horizontal for lustre, sense reflected light and converts it to



voltage, which is calibrated for colour and lustre. The specimen to be measured should be placed beneath the instrument and TEST button is pressed for results. The values of colour will be with respect to whiteness and the lustre value will be shown as the ratio of specular reflection value divided by the Diffused reflection value (S/D). The instrument has wooden platform on which specimens are placed to avoid external lights interference with the system.

### **2.3 Sensitivity**

The sensitivity of the instrument for colour measurement shall be 0.1 percent. If the sensitivity of the instrument more than 2 percent, mention in final report.

### **2.4 Calibration**

The same fibre specimen shall be checked in colour lustre meter and colour spectrophotometer. The Whiteness Index value of the spectrophotometer shall be set in the digital instrument. It is advice to calibrate at least once in a year for better accuracy and precision.

## **4 SAMPLING**

20 full-length reeds shall be taken from the fibre reed randomly from the representative sample. The reeds shall be cleaned and made free from dust and dirt. The sample portion shall be placed on the platform and locked. Manually cleaning is recommended.

## **5 OPERATIONS OF THE INSTRUMENT**

- a) Adjustments appropriate to instruments shall be made, especially checking the battery charge percentage as described in the user manual. When the battery level percentage of the meter is less than 50 percent, measurement shall not be conducted.
- b) The wooden platform shall be locked after the fibre is placed on it.
- c) On pressing the test switch, the instrument display shall show the colour (percent) and lustre value.
- d) Regularly clean the instrument with a brush to ensure that the photodiode sensors are free from dust.
- e) Whenever a battery discharges too early, it shall be replaced.

## **6 PROCEDURE**

- a) Assure that instrument is in proper operating conditions and check the calibration.
- b) Place the reed portion of the sample on platform and secure.
- c) A colour meter shall be placed on the platform having the fibre.
- d) The colour shall be checked at three positions of the reed (top, middle, and lower) and take three reading of same location.

## **7 CALCULATIONS**

The arithmetic mean of nine readings shall be considered.