

भारतीय मानक ब्यूरो
BUREAU OF INDIAN STANDARDS

Draft for comments only

Doc: TXD 32 (25487) WC

भारतीय मानक मसौदा

वस्त्रादि — ऑक्सीजन सूचकांक द्वारा ज्वलनशीलता ज्ञात करना

(आई एस 13501 का पहला पुनरीक्षण)

Draft Indian Standard

Textiles — Determination of Flammability by Oxygen Index

(*First Revision of IS 13501*)

ICS 13.220.40

Not to be reproduced without permission of
BIS or used as Standard

Last date for receipt of comment is
01 July 2024

Textiles Protective Clothing Sectional Committee, TXD 32

FOREWORD

(Formal clauses will be added later)

Oxygen index results obtained using the method prescribed in this standard can provide a sensitive measure of the burning characteristics of a textile material intended for clothings under certain controlled laboratory conditions, and hence may be useful for quality control purposes. The results obtained are dependent upon the shape, orientation and isolation of the test specimen and conditions of ignition. For particular materials or applications, it may be necessary or appropriate to specify different test conditions. Such requirements should be referred to in other standards.

This standard was originally published in 1992. It has been revised to incorporate following changes:

- i) References of Indian standards have been updated

- ii) Amendment has been incorporated.

Results obtained from test specimens of differing thickness or by using different ignition procedures may not be comparable and no correlation with flammability behaviour under other fire conditions is implied. Results obtained in accordance with this standard must not be used to describe or appraise the fire hazard presented by a particular textile material or shape under actual fire conditions, unless used as one element of a fire risk assessment that takes into account all the factors pertinent to the assessment of the fire hazard of a particular application for the textile material.

In reporting the result of a test or analysis made in accordance with this standard, if the final value, observed or calculated, is to be rounded off, it shall be done in accordance with IS 2 : 2022 'Rules for rounding off numerical values (*second revision*)'.

1 SCOPE

1.1 This standard specifies method for determining the minimum concentration of oxygen, in admixture with nitrogen that will support combustion of small vertical test specimens under specified test conditions. The results are defined as oxygen index values.

1.2 The method prescribed in this standard provides a sensitive measure of the burning characteristics of textile materials intended for clothings.

2 REFERENCES

The standards listed in Annex A contain provisions which through reference in this text, constitute provisions of this standard. At the time of publication, the editions indicated were valid. All standards are subjected to revision, and parties to agreements based on this standard are encourage to investigate the possibility of applying the most recent editions of the standards indicated in Annex A.

3 PRINCIPLE

3.1 A small test specimen is supported vertically in a mixture of oxygen and nitrogen flowing upwards through a transparent chimney. The upper end of the specimen is ignited. The minimum concentration of oxygen in a mixture of oxygen and nitrogen flowing upward in a test chimney that will just support combustion is measured under equilibrium conditions of candle-like burning. The equilibrium is established by the relation between the heat generated from the combustion of the specimen and the heat lost to the surroundings as measured by one or the other of two arbitrary criteria, namely, the period for which burning continues, or the length of specimen burnt. This point is approached from both sides of the critical oxygen concentration in order to establish the oxygen index.

4 DEFINITION

4.0 For the purpose of this standard, the definitions given in IS 11871 and the following definition shall apply.

4.1 Oxygen Index

The minimum concentration of oxygen by percentage volume in a mixture of oxygen and nitrogen that will just support combustion of a material under specified test conditions.

5 APPARATUS

The following apparatus shall be arranged as indicated in Fig. 1 and 2.

5.1 Test Chimney

A heat resistant glass tube supported vertically on a base through which oxygen-containing gas mixture can be introduced. The preferred dimensions of the chimney are 450 mm minimum height and 75 mm minimum diameter cylindrical bore. The upper outlet shall be restricted as necessary by an overhead cap having an outlet small enough to produce an exhaust velocity of at least 90 mm/s from a flow rate within the chimney of 30 mm/s (*see Note*). Chimneys of other dimensions, with or without restricted outlets, may be used, if shown to give equivalent results. The bottom of the chimney, or the base upon which the chimney is supported, shall incorporate a means for distributing evenly the gas mixture entering the chimney. The preferred means comprises solid glass beads of between 3 and 5 mm diameter, in a layer between 80 and 100 mm deep. Other means, such as radial manifolds, may be used, if shown to give equivalent results. A porous screen may be mounted below the level of the specimen holder, to prevent falling combustion debris from fouling the gas entry and distribution paths. The chimney support may incorporate a levelling device and indicator, to facilitate vertical alignment of the chimney and a test specimen supported therein. A dark background may be provided to facilitate observation of flames within the chimney.

NOTE— For tubes of 75 to 100 mm diameter, a cap converging to an outlet of 40 mm diameter at a level at least 10 mm above the top of the cylindrical chimney has been found satisfactory.

5.2 Test Specimen Holder

Suitable for supporting a specimen vertically in the centre of the chimney. The specimen shall be supported by both vertical edges in a frame equivalent to that illustrated in Fig. 2, with reference marks at 20 mm and 100 mm below the top of the frame. The profile of the holder and its support should be smooth to minimize induction of turbulence in the rising flow of gas.

5.3 Gas Supply

Comprising commercial grade oxygen and nitrogen. If an air supply is used with oxygen or nitrogen, it shall be clean and dry. The gas supply system shall incorporate a drying device. The constituent gas supply lines shall be linked in a manner which thoroughly mixes the gases, before they enter the gas distribution device at the base of the chimney, so that the variation in oxygen concentration in the gas mixture rising in the chimney, below the level of the test specimen, is less than 0.2 percent (v/v).

5.4 Gas Measurement and Control Devices

Suitable for establishing the concentration of oxygen and nitrogen in the gas mixture entering the chimney with an accuracy of ± 1.0 percent (v/v).

NOTE — System of measurement and control that have proved satisfactory include the following:

- a) Needle valves on individual and mixed gas supply lines, a paramagnetic oxygen analyzer that continuously samples the mixed gas, and a flowmeter to indicate when the gas flow through the chimney is within the required limits;
- b) Calibrated orifices, gas pressure regulators and pressure gauges on the individual gas supply lines; Or
- c) Needle valves and calibrated flowmeters on the individual gas supply lines.

Systems (b) and (c) may require calibration after assembly to ensure that the compounded errors of the component parts do not exceed the requirements of **5.4**.

5.5 Flame Igniter

Comprising a tube that can be inserted into the chimney to apply to the test specimen a flame issuing from an outlet of 2 ± 1 mm diameter at the end of the tube. The flame fuel shall be commercially available liquefied petroleum gas (LPG). The fuel supply shall be adjusted so that the flame will project 6 to 25 mm vertically downwards from the outlet when the tube is vertical within the chimney and the flame is burning within the chimney atmosphere.

5.6 Timing Device

Capable of measuring periods up to 10 min with an accuracy of 5 seconds.

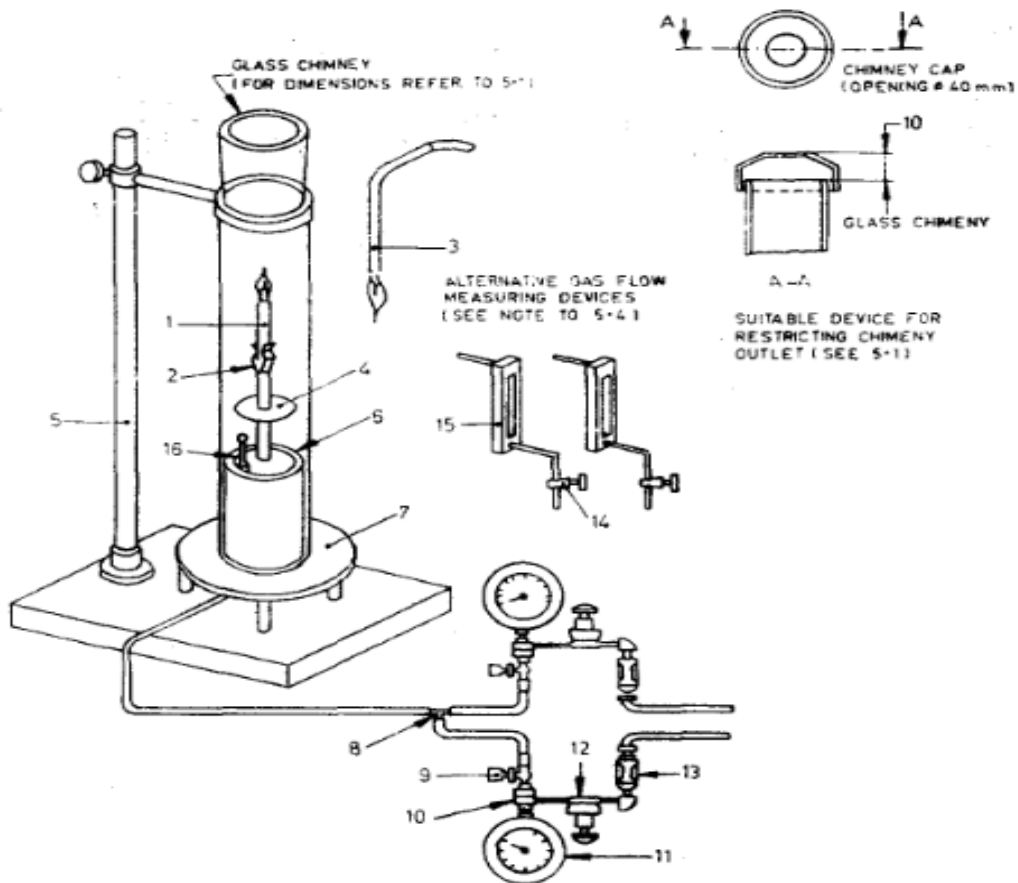

- | | | |
|------------------------------|-----------------------|---------------------------------|
| 1 Burning test specimen | 7 Base plate | 12 Precision pressure regulator |
| 2 Specimen holder | 8 Gas premixing point | 13 Filter |
| 3 Igniter | 9 Cut-off valve | 14 Needle valve |
| 4 Debris screen of wire mesh | 10 Orifice in holder | 15 Gas flow meter |
| 5 Chimney support | 11 Pressure gauge | 16 Temperature sensor |
| 6 Bead bed | | |

FIG 1 DIAGRAM OF TYPICAL APPARATUS FOR DETERMINATION OF OXYGEN INDEX

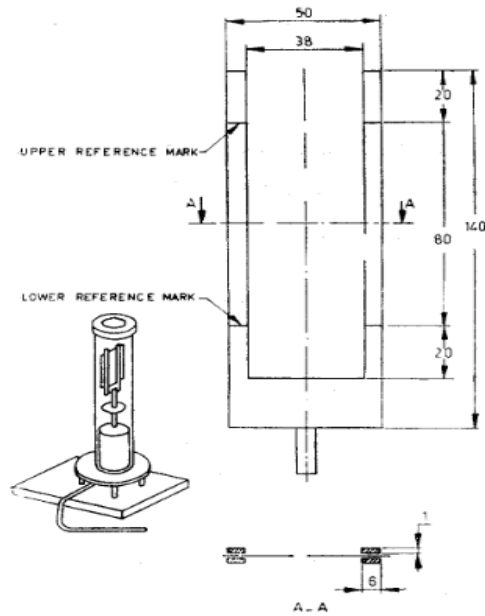

All dimensions in millimetres with tolerances of ± 0.25 mm.

FIG 2 FRAME DESIGN FOR SUPPORTING NON-SELF-SUPPORTING TEST SPECIMENS

5.7 Soot, Fumes Heat-Extraction System

Providing sufficient ventilation or exhaust to remove fumes or soot expelled from the chimney without disrupting the gas-flow rate or temperatures in chimney.

NOTES

1 If soot-generating materials are being tested, the glass chimney may require cleaning to maintain good visibility, and the gas inlets, or inlet screen, and temperature sensor (if fitted) may also require cleaning to function properly. Suitable precautions should be taken to protect personnel from noxious materials or burns during testing or cleaning operations.

2 Any other suitable oxygen analyzer equipment based on the principle specified in this standard and capable of giving reliable and reproducible results directly, may also be used.

6 CALIBRATION OF EQUIPMENT

6.1 For compliance with this method, calibrate the equipment periodically in accordance with the instructions given in Annex B so that the maximum interval between recalibration and use complies with the periods stated in Table 1.

Table 1 Equipment Calibration Frequencies

(Clause 6.1)

SI No.	Item	Maximum Period
(1)	(2)	(3)
i)	Gas-flow rate controls	6 months
ii)	Oxygen concentration controls	6 months

iii)	Gas system joints (as required by B-2 in Annex B):	
	a) for joints disturbed use or cleaning of the apparatus	24 hours
	b) for undisturbed joints	6 months

7 PREPARATION OF TEST SPECIMENS

7.1 Sampling

Obtain a sample sufficient for preparation of 5 to 10 test specimens. The sample shall be taken, if relevant, in accordance with the materials specification or otherwise specified.

NOTE — For a material for which the oxygen index is known to within ± 2 , 5 test specimens may be sufficient. For materials of unknown oxygen index, or which exhibit erratic burning characteristics, between 8 and 10 test specimens may be required.

7.2 Test Specimen Dimensions and Their Preparation

Cut test specimens of size $140 \pm 5 \text{ mm} \times 52 \pm 0.5 \text{ mm}$. Ensure that the surfaces of the specimens are clean and free from flaws that could affect burning behaviour. The edges of the specimens shall be relatively smooth and free from furr or burrs of material left from machining.

7.3 Marking of Test Specimens

For monitoring the distance over which a specimen burns, it may be marked with transverse lines at one or more levels which are dependent upon the specimen form and the ignition procedure to be used. If wet inks are used, the marks shall be dry before the specimen is ignited.

7.3.1 The reference marks for testing specimens are carried by the supporting frame (*see* Fig. 2).

7.4 Conditioning and Testing Atmospheres

7.4.1 Conditioning

Before testing, condition the specimens for 24 hours in a standard atmosphere of 65 ± 2 percent relative humidity and 27 ± 2 °C temperature (*see* IS 6359). If the test is not carried out immediately after conditioning, place the specimens in a tightly closed container until the commencement of the test. Each specimen shall be tested within two minutes of removing it from either the conditioning atmosphere or the container.

7.4.2 Testing Atmosphere

Carry out the test in a substantially draught-free room or enclosure in an atmosphere of relative humidity between 20 to 80 percent and temperature between 20 to 35 °C.

8 PROCEDURE

8.1 Setting up the Apparatus and Test Specimen

8.1.1 Re calibrate equipment components, if necessary (*see* **6.1** and Annex B).

8.1.2 The test shall be conducted in the testing atmosphere specified in **7.4.2**

8.1.3 Select an initial concentration of oxygen to be used. When possible, this may be based on experience of results for similar materials. Alternatively, try to ignite a test specimen in air, and note the burning behaviour. If the specimen burns rapidly, select an initial concentration of about 18 percent (v/v) of oxygen; if the test specimen burns gently or unsteadily select an initial oxygen concentration of about 21 percent WO; if the specimen does not continue to burn in air, select an initial concentration of at least 25 percent (v/v), depending upon the difficulty of ignition or the period of burning before extinguishment in air.

8.1.4 Ensure that the test chimney is vertical (*see* Fig. 1). Mount a specimen vertically in the centre of the chimney so that the top of the specimen is at least 100 mm below the open top of the chimney and the lowest exposed part of the specimen is at least 100 mm above the top the gas distribution device at the base of the chimney (*see* Fig. 1 or Fig. 2 as appropriate).

8.1.5 Set the gas mixing and flow controls so that an oxygen/nitrogen mixture containing the desired concentration of oxygen is flowing through the chimney at a rate of 40 ± 10 mm/s. Allow the gas to flow for at least 30 seconds to purge the system prior to ignition, of each specimen, and maintain the flow without change during ignition and combustion of each specimen. Ignite the test specimen as described in **8.2**.

8.1.6 Record the oxygen concentration used as the volume percent calculated according to the equations given in Annex C.

8.2 Igniting the Test Specimen

8.2.1 Apply the lowest visible part of the flame to the top of the specimen using a sweeping motion, if necessary, to cover the whole surface, but taking care not to maintain the flame against the vertical faces or edges of the specimen. Apply the flame for up to 30 seconds, removing it every 5 seconds for just sufficient time to observe whether or not the entire top surface of the specimen is burning.

8.2.2 Consider the specimen to be ignited, and commence measurement of the period and distance of burning, as soon as removal of the igniter, after a contact period increment of 5-seconds, reveals, burning supported by the whole of the top end surface of the specimen.

8.3 Assessing Burning Behaviour

8.3.1 For the purpose of **8.3.2** to **8.3.6** inclusive, observe and terminate the burning of individual test specimens as follows:

8.3.2 Commence measurement of the period of burning as soon as the specimen has been ignited in accordance with **8.2**, as applicable, and observe its burning behavior. If burning ceases but spontaneous re-ignition occurs in less than 1 second, continue the observation and measurements.

8.3.3 The concentration of oxygen is too high and must be reduced if the specimen burns and either the period or the extent of burning exceeds the relevant limits specified in Table 2. The concentration of oxygen must be raised if the flaming of the specimen extinguishes before meeting the criteria specified in Table 2. Do not adjust the oxygen concentration after igniting the specimen.

Table 2 Criteria for Oxygen Index Measurements
(Clauses 8.3.3 and 8.3.5)

SI No.	Period of Burning After Ignition (seconds)	Extent of Burning
(1)	(2)	(3)
i)	180	58 mm below the top of the specimens

NOTE—These criteria do not necessarily produce equivalent oxygen index results for specimens of differing shape or tested using different conditions or procedures.

8.3.4 Adjust the oxygen concentration, insert a new specimen, or if the previous specimen is long enough, turn it end for end or cut off the burnt end, then purge and re-ignite.

8.3.5 Continue repeating **8.1.5** to **8.3.4** until the critical concentration of oxygen is determined. This is the lowest oxygen concentration that will meet the criteria specified in Table 2. At the next lower concentration that will give a difference in oxygen index of 0.2 percent or less, the specimen should not meet the criteria specified in Table 2.

NOTES

1 The critical oxygen concentration has been found to be dependent on the temperature of the specimen at ignition and the temperature of the gas mixture.

2 For a material having consistent burning characteristics, the difference in oxygen concentration between and extinguishing as specified in 8.3.2 will be reproducible within 0.1 percent to 0.3 percent depending on the sensitivity of the flow measuring equipment and upon the particular oxygen concentration involved. Some materials, however, exhibit erratic burning characteristics because of inhomogeneity, char formation, dripping, bending, etc, which cause less reproducible results. In such cases, the critical concentration may be determined by a statistical testing method as given in *American Statistical Association Journal*, pp-967-970 (1965).

8.3.6 Perform the test at least three times by starting at a slightly different flow rate still within 30 to 50 mm/second limits and again performing the procedure from 8.1.5 to 8.3.5.

9 CALCULATIONS

9.1 Calculate the oxygen index, n , of the material for each replicate in 8.3.6 by the formula:

$$n = \frac{100O_2}{O_2 + N_2}$$

where

O_2 = the volumetric flow of oxygen in cm^3/s , at the concentration determined in 8.3.5; and

N_2 = the corresponding volumetric flow rate of nitrogen in cm^3/s .

NOTE — If an oxygen analyzer is used, the oxygen index should be determined using the readout from the particular instrument used.

9.1.1 If air is used and either oxygen or nitrogen is added as required, calculate n assuming that air contains 20.9 percent oxygen as follows:

$$n = (100 \times O_2) + (20.9 \times A) : (O_2 + N_2 + A)$$

where

A = the volumetric flow rate of air in cm^3/s .

10 TEST REPORT

10.1 The test report shall include the following:

- a) Identification of the material tested, including, where relevant, the type of material, density, previous history, and the specimen orientation with respect to any anisotropy in the material or sample;
- b) The test specimen dimensions;
- c) The igniter used;
- d) The individual oxygen index values found for each of the tests, and average index value;
- e) A description of any relevant ancillary characteristics or behaviour, such as charring, dripping, severe shrinkage, erratic burning, after-glow;
- f) Any variations from the requirements of this standard;
- g) Any other information required by the law in force

ANNEX A

(Clause 2)

LIST OF REFERRED STANDARDS

<i>IS No.</i>	<i>Title</i>
IS 6359: 2023	Method for conditioning of textiles
IS 11871: 1986	Methods for determination of flammability and flame resistance of textile fabrics

ANNEX B

(Clauses 6.1 and 8.1.1 and Table 1)

CALIBRATION OF EQUIPMENT

B-1 CALIBRATION OF GAS FLOW RATE CONTROLS

B-1.1 Check the system for indicating the gas-flow rate through the chimney using a water-sealed rotating drum meter (wet test meter), or an equivalent device, with an accuracy equivalent to ± 2 mm/s flow rate through the chimney.

B-1.2 Estimate the flow rate by dividing the total gas-flow rate through the chimney by the cross-sectional area of the bore of the chimney, for example by using the equation.

$$F = 1.27 \times 10^6 \frac{q_v}{D_2}$$

Where

F = the flow rate through the chimney, in mm per second:

q_v = the total gas-flow through the chimney, in litres per second

D = the diameter of the bore of the chimney, in millimeters.

B-2 CALIBRATION OF OXYGEN CONCENTRATION CONTROLS

B-2.1 Check the the concentration of oxygen in the mixture of gases flowing into the chimney to an accuracy of 0.1 percent (v/v) of mixture, either by sampling the chimney atmosphere for analysis or by using an independently calibrated oxygen analyzer *in situ*. Integral oxygen analyzers may be calibrated using standard oxygen/ nitrogen mixtures. The checks should be carried out for at least three different nominal concentrations, representing respectively maximum, minimum and intermediate levels for the oxygen concentration range for which the equipment is to be used.

B-2.2 Carry out leak-tests on all joints where leaks could change the oxygen concentration levels in the chimney from the concentration levels set or indicated.

B-3 CALIBRATION OF COMPLETE EQUIPMENT

B-3.1 Check the performance of the equipment for a specific test procedure, by testing a calibrated material and comparing the measured results with the expected result for the calibrated material. For information on the availability and use of calibrated materials, *see* Annex C.

ANNEX C

(Clause 8.1)

CALCULATION OF OXYGEN CONCENTRATION

B-1 Calculate the oxygen concentrations according to the following equation:

$$C_o = \frac{100 V_o}{V_o + V_N}$$

Where

C_o = the oxygen concentration, in percent by volume;

V_o = the volume of oxygen per volume of mixture; and

V_N = the volume of nitrogen per volume of mixture.

NOTES

1 If an oxygen analyzer is used, the oxygen concentration should be determined using the readout from the particular instrument used.

2 If the result is calculated from flow or pressure data for individual gas streams contributing to the mixture, it is necessary to allow for the proportion of oxygen present in streams other than a pure oxygen supply. For example, for mixtures made using air mixed

with oxygen of 98.5 percent (v/v) purity or with nitrogen containing 0.5 percent (v/v) of oxygen, the oxygen concentration, in percent by volume, should be calculated using the relationship:

$$C_0 = \frac{98.5 V_o^t + 20.9 V_A^t + 0.5 V_N^t}{V_o^t + V_A^t + V_N^t}$$

Where

V_o^t = the volume of oxygen stream used, per volume of mixture;

V_A^t = the volume of air stream used, per volume of mixture; and

V_N^t = the volume of nitrogen stream used, per volume of mixture.

assuming that the streams are at the same pressure and temperature.

For mixture based on two gas streams, V_o^t, V_A^t, V_N^t becomes zero, as appropriate

