

BUREAU OF INDIAN STANDARDS

DRAFT FOR COMMENTS ONLY

(Not to be reproduced without permission of BIS
or used as an Indian Standard)

भारतीय मानक मसौदा

सड़क वाहन - ट्रैक्टरों और अर्ध-ट्रेलरों के बीच यांत्रिक युग्मन -
भाग 1: सामान्य कार्गो के लिए ट्रैक्टरों और अर्ध-ट्रेलरों के बीच
अंतर्विनिमयता

(आई एस 8007 का दूसरा पुनरीक्षण)

Draft Indian Standard

**Road vehicles — Mechanical coupling between tractors and semi-trailers
— Part 1: Interchangeability between tractors and semi-trailers for
general cargo**

(Second Revision of IS 8007)

ICS : 43.040.70

Transport Tractors, Trailers and Industrial Trucks
Sectional Committee, TED 22

Last date for receipt of Comments
is 30/10/2023

Transport Tractors, Trailers and Industrial Trucks Sectional Committee, TED 22

FOREWORD

(Formal clause to be added later on)

This standard was first published in 1976 which was based on ISO 1726: 1973. Subsequent to the revision in the ISO 1726: 2000, this standard was revised in 2004 to bring it in line with the revised ISO Standard. This second revision has been undertaken to publish it as modified adoption of ISO 1726-1.

In this revision the following are the major changes:

- 1) Clause 3.1- Height of fifth wheel of laden tractor has been modified.

The composition of the Committee responsible for the formulation of this standard is given at Annex B (Will be added later).

For the purpose of deciding whether a particular requirement of this standard is complied with, the final value, observed or calculated, expressing the result of a test or analysis, shall be rounded off in accordance with IS 2: 2022 'Rules for rounding off numerical values (*revised*)'. The number of significant places retained in the rounded off value should be the same as that of the specified value in this standard.

Draft Indian Standard

**Road vehicles — Mechanical coupling between tractors and semi-trailers
— Part 1: Interchangeability between tractors and semi-trailers for
general cargo**

(Second Revision)

1 SCOPE

This standard specifies dimensions to ensure interchangeability between a tractor vehicle and a coupled semi-trailer, the two together constituting an articulated vehicle. It specifies certain interchangeability dimensions, including those of the gooseneck contour, as well as operating dimensions related to angle values. The specifications permit the same semi-trailer to be used with either two- or three-axle tractors.

Annex A gives interface technical specifications for tractors designed for towing high-cube semi-trailers, including ISO containers having an external height of 2.9 m.

This standard covers articulated vehicles used in commercial cargo transport of the greatest possible variety. However, it may not be applicable to special combination types such as low-bed or tipper vehicles.

This standard does not provide limitations of maximum gross mass and overall dimensions, which are generally laid down by legislative requirements.

2 REFERENCE

The following Standard is necessary adjunct to this standard. At the time of publication, the edition indicated was valid. All Standards are subject to revision, and parties to agreements based on this standard are encouraged to investigate the possibility of applying the most recent edition of the standard indicated below:

<i>ISO No.</i>	<i>Title</i>
ISO 337	Road vehicles — 50 semi-trailer fifth wheel coupling pin — Basic and mounting interchangeability dimensions.

3 INTERCHANGEABILITY DIMENSIONS

3.1 Height of Fifth Wheel of Uncoupled Tractor — The height ' h ' above GRP of the fifth wheel of an uncoupled tractor shall be *Max.* 1500 mm. In case of 90 mm fifth wheel coupling height ' h ' in uncoupled condition shall be *Max.* 1550 mm.

3.2 Forward-Clearance-Zone Radius of Semi-Trailer — The semi-trailer's forward-clearance-zone radius, d (*see* Fig. 2), shall not exceed 2040 mm.

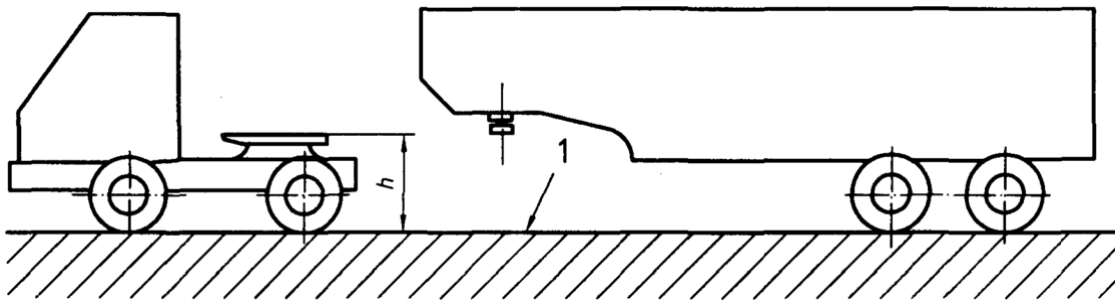

Key

1 GRP

FIG.1 — HEIGHT OF FIFTH WHEEL

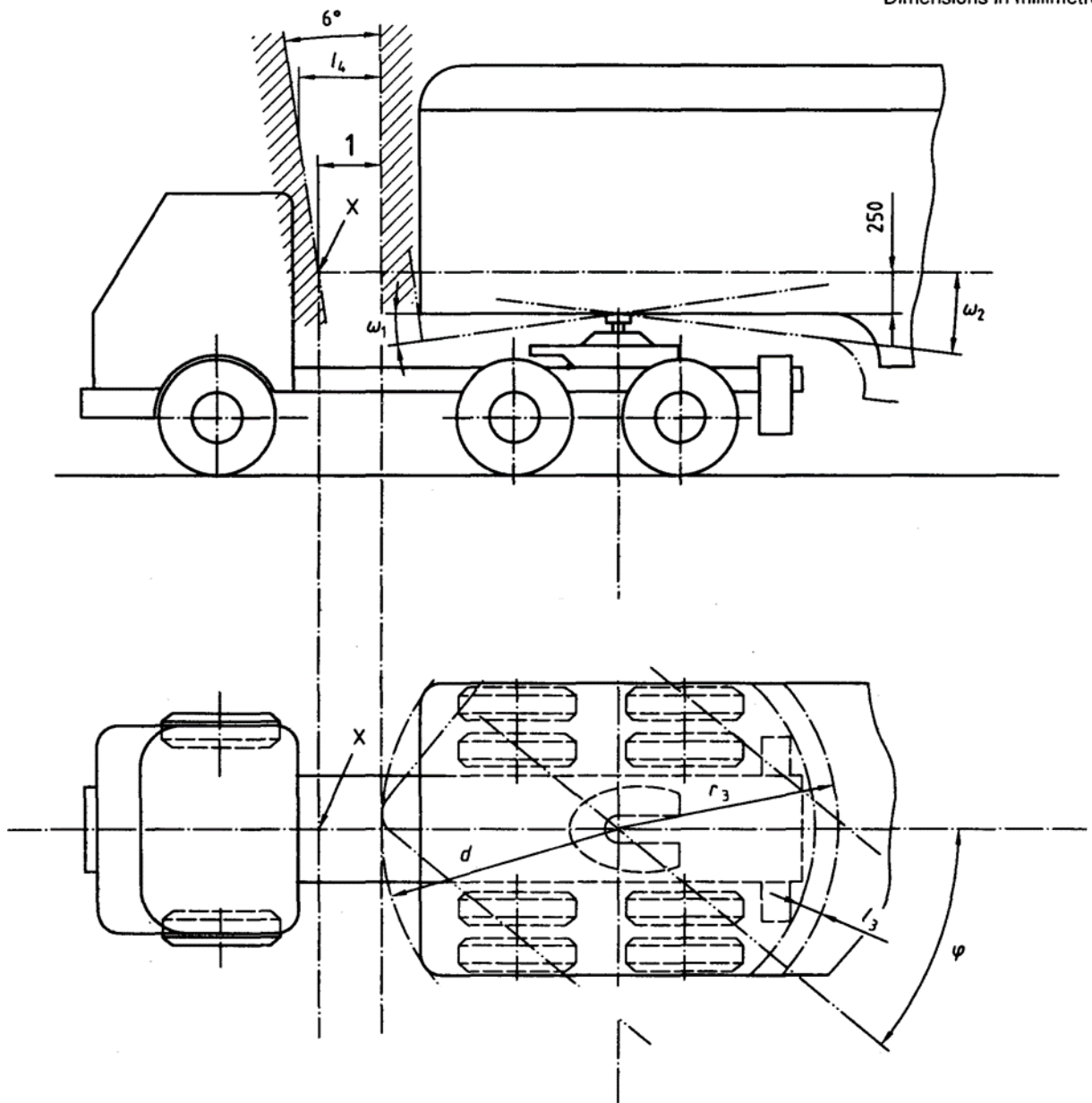

Key

1 l_4 at point X = 80 mm Min

FIG. 2 — FREE SPACE BETWEEN TRACTOR AND SEMI-TRAILER

3.3 Gooseneck Contour — The gooseneck shall be located on the outside of a surface consisting of two planes and one surface of revolution interconnected without forming a step. These three parts of the total surface are shown in Fig. 3, 4 and 5 and defined as follows:

- A plane horizontal and perpendicular to the axis of the coupling pin with a length of l_2 (AB) and a width of that of the semi-trailer, limited by the intersection of
- A second plane of the same width, making an angle γ with the first plane, limited by the intersection of
- A surface of revolution generated by rotating the vertical portion DE, situated at a radius, r_3 , from the axis of the coupling pin, and an arc of a circle of radius r_2 (CD — C'D'), between the second plane and DE, such that no discontinuity arises.

The values adopted for these generator elements:

- $l_2 = 750$ mm
- $\gamma = 4^\circ$
- $r_2 = 450$ mm
- $r_3 = 2300$ mm

The above dimensions allow the determination of the center of the circle of radius r_2 .

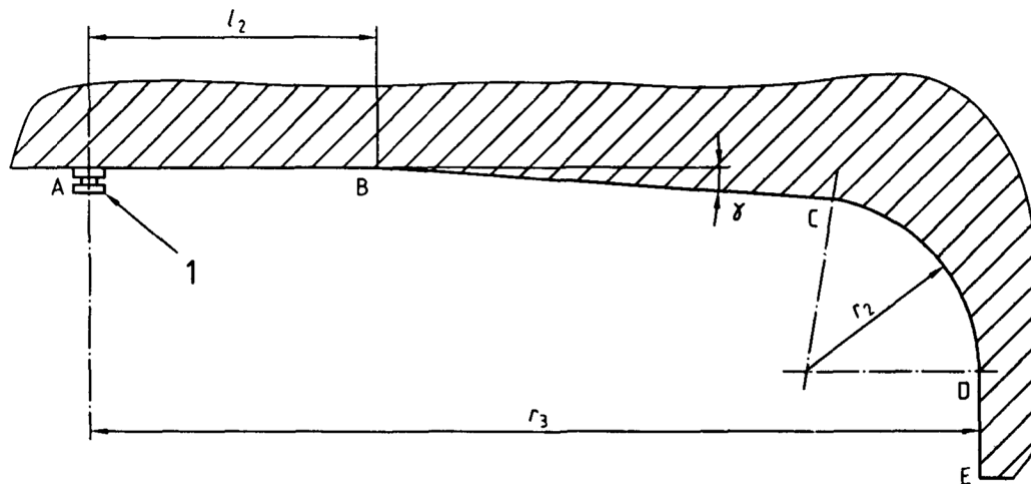

Key

- 1 Coupling pin (in accordance with ISO 337)
- 2 Centre profile
- 3 Outer profile

FIG. 3 GOOSENECK CONTOUR: GENERATOR ELEMENTS

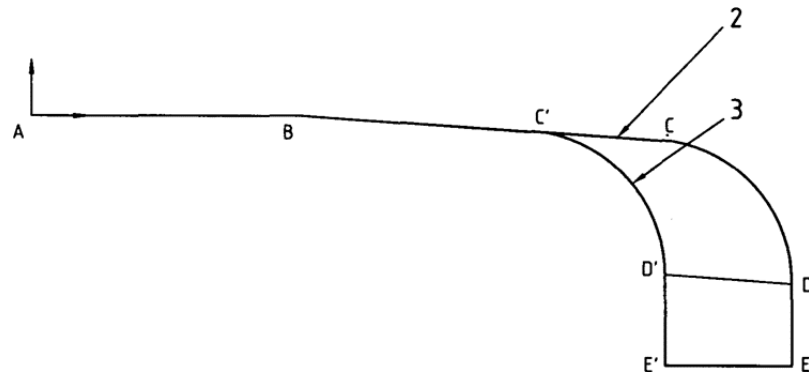

Key

- 1 Coupling pin (in accordance with ISO 337)
- 2 Centre profile
- 3 Outer profile

FIG. 4 GOOSENECK CONTOUR: CENTER AND OUTER PROFILES

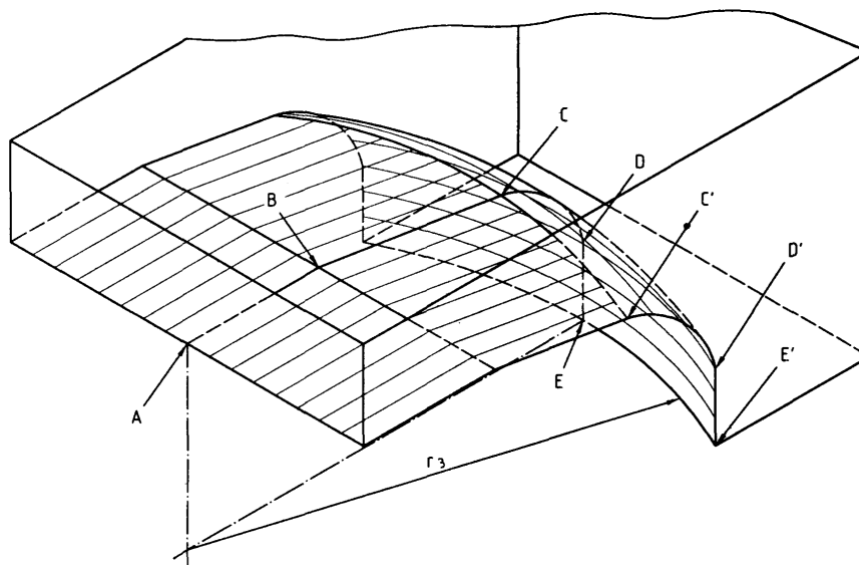

Key

- 1 Coupling pin (in accordance with ISO 337)
- 2 Centre profile
- 3 Outer profile

FIG. 5 GOOSENECK CONTOUR: THREE-DIMENSIONAL VIEW

4 OPERATING DIMENSIONS

4.1 Angles of Inclination of Semi-Trailer in Relation to Tractor.

The tractor shall be constructed so that tractor and semi-trailer components, except for those concerned with articulation, do not make contact with each other when the articulated vehicle is running in a straight line, and when the angle of inclination of the semi-trailer relative to the tractor does not exceed the following values (*see* Fig. 2):

$$\begin{aligned}\omega_1 &= 6^\circ \text{ towards the front;} \\ \omega_2 &= 7^\circ \text{ towards the rear.}\end{aligned}$$

For the purposes of the measurement of ω_1 and ω_2 , the fifth wheel plate is assumed to be situated in a horizontal plane. The tractor shall be set at the attitude which corresponds to the design laden condition when the tractor is standing on a horizontal plane.

4.2 Lateral Inclination

When the trailer is at a lateral inclination, δ (*see* Fig. 6), of a maximum of 3° relative to the tractor chassis, there shall be no contact between the tractor chassis and the semi-trailer.

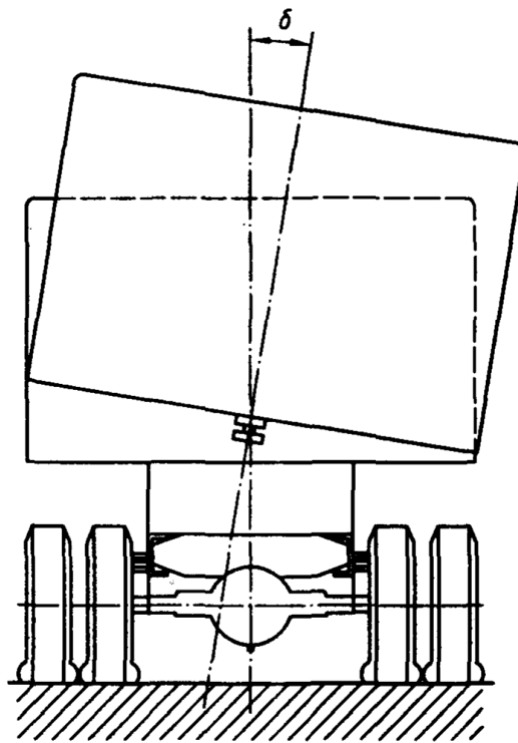

FIG. 6 — LATERAL INCLINATION

4.3 Angle of Articulation

The angle of articulation φ (*see* Fig. 2) is the projection of the angle between the longitudinal axes of the tractor and semi-trailer in the horizontal plane.

The articulation of the vehicle shall be such that no contact is made between the semi-trailer and the tyres or spray-suppression equipment of the tractor, taking into account the maximum value $\omega_2 = 7^\circ$ for all angles φ up to 25° , for both two- and three-axle tractors.

Under maneuvering conditions, the angle of articulation φ shall be able to reach 90° , with the angle of inclination ω_2 varying from 7° to 3° as φ varies from 25° to 90° .

4.4 Free Space between Tractor and Semi-Trailer

The free space between the tractor and semi-trailer is measured as follows (*see* Fig. 2):

- a) l_3 is the distance between two cylinders of revolution, both having the kingpin axis as their axis. One of these cylinders has the radius r_3 (lower part of the gooseneck), the other cylinder is that of the smallest radius within which all points of the rear part of the tractor are located. The distance l_3 shall be a minimum of 100 mm.
- b) l_4 is the horizontal clearance between a cylinder of revolution having as its axis the axis of the fifth wheel coupling and a conical surface of revolution having the same axis. The cylinder of revolution has the radius d . The conical surface is generated by a line making an angle of 6° from the vertical towards the front of the tractor. This line is positioned in such a way that the conical surface does not interfere with any point of the tractor located above the fifth-wheel coupling horizontal plane. A point, X, of this surface is positioned on the Plane of symmetry of the semi-trailer at a height of 250 mm above the fifth wheel coupling face. At X, l_4 shall be a minimum of 80 mm.

5 DESIGNATION

Tractors and semi-trailers in compliance with the requirements of this standard (excluding Annex A) shall be designated:

Tractors and semi-trailers IS 8007 - S.

Tractors and semi-trailers in compliance with Annex A shall be designated:

Tractors and semi-trailers IS 8007 - A.

6 BIS CERTIFICATION MARKING

6.1 Each coupling may also be marked with the Standard Mark.

6.2 The use of the Standard Mark is governed by the provisions of the *Bureau of Indian Standards Act, 2016* and the Rules and Regulations made thereunder. The details of conditions under which the license for the use of the Standard Mark may be granted to manufacturers or producers may be obtained from the Bureau of Indian Standards.

ANNEX A
(*Clauses 1 and 5*)

(Normative)

**INTERFACE SPECIFICATIONS FOR TRACTORS DESIGNED FOR TOWING HIGH-CUBE
SEMI- TRAILERS**

For tractors designed to tow high-cube semi-trailers, including ISO containers having an external height of 2.9 m, the requirements instead of those stated in **3.2** are:

- The height h above GRP of the fifth wheel of a laden tractor shall be in the range 1 025 mm to 1 100 mm;
- The height h above GRP of the fifth wheel of an uncoupled tractor shall not exceed 1 150 mm.

Although three-axle tractors are not excluded from Annex A, it might be difficult to apply its specifications and at the same time comply with the angles of inclination and other requirements specified elsewhere in this standard. Any deviations from compliance should be carefully evaluated by those competent to do so in order to decide whether safe and satisfactory operation can be ensured.