

BUREAU OF INDIAN STANDARDS

DRAFT FOR COMMENTS ONLY

(Not to be reproduced without permission of BIS or used as an Indian Standard)

भारतीय मानक मसौदा

पावरचालित औद्योगिक ट्रकों की पारिभाषिक शब्दावली
(चौथा पुनरीक्षण)

POWERED INDUSTRIAL TRUCKS - TERMINOLOGY
(Fourth Revision)

ICS: 53.060

© BIS 2024

Transport Tractors, Trailers and Industrial
Trucks Sectional Committee, TED 22

Last date for receipt of comments
is 28/10/2024

Transport Tractors, Trailers and Industrial Trucks Sectional Committee, TED 22

FOREWORD

(Formal clause to be added later on)

The objective of this standard is to define the various terms used in the classification and characteristics of powered industrial trucks. It is expected that this standard will provide common parlance to the manufacturers as well as to the users of industrial trucks terms in this field, avoiding ambiguity in interpretation.

In this fourth revision following changes have been incorporated:

- a) References, ICS No. have been updated; and
- b) Other editorial changes have been done to bring the standard in the latest style and format of Indian Standards

The committee responsible for the preparation of this standard is given in Annex B (**Will be added later**).

For the purpose of deciding whether a particular requirement of this standard is complied with, the final value, observed or calculated, expressing the result of test or analysis, shall be rounded off in accordance with IS 2: 2022 'Rules for rounding off numerical values (*second revision*)'. The number of significant places retained in the rounded off value should be the same as that of the specified value in this standard.

Draft Indian Standard

POWERED INDUSTRIAL TRUCKS - TERMINOLOGY
(Fourth Revision)

1 SCOPE

1.1 This standard specifies the various terms used for powered industrial trucks, its components and accessories.

1.2 Some terms are not being defined, because they are self-evident or because they are in general use elsewhere such as petrol trucks/diesel trucks.

1.3 This standard also defines the terms relating to industrial trailer and operating areas where such trucks are expected to be used (*see Annex A*).

2 REFERENCES

The standards given below contain provisions which, through reference in this text, constitute provision of this standard. At the time of publication, the editions indicated were valid. All standards are subject to revision, and parties to agreements based on this standard are encouraged to investigate the possibility of applying the most recent editions of these standards.

<i>IS No.</i>	<i>Title</i>
IS/ISO 22877: 2004	Castors and wheels - Vocabulary, symbols and multilingual terminology
IS 7451 (Part 1): 2020	Reciprocating internal combustion engines: Part 1 General definitions
IS 7451 (Part 2): 2006	Reciprocating internal combustion engines: Part 2 Definitions of location of an engine
IS 7451 (Part 3): 1974	Reciprocating internal combustion engines: Part 3 Definitions of right-hand and left-hand single bank engines
IS 7451 (Part 4): 1974	Reciprocating internal combustion engines: Part 4 Designation of direction of rotation
IS 7451 (Part 5): 1974	Reciprocating internal combustion engines: Part 5 Designation of the cylinders
IS 7451 (Part 6): 2007	Reciprocating internal combustion engines: Part 6 Hand operated control devices - Standard direction of motion
IS 7570: 1975	Glossary of terms relating to fork arms and attachments of forklift trucks

3 TERMS RELATING TO TRUCKS BY CLASSIFICATION

The terms are defined in order of classification. The classification is based on:

- a) Mode of action;
- b) Power of source;
- c) Mode of control;
- d) Height of lift; and
- e) Mode of travel.

3.1 Classification by Mode of Action

3.1.1 *Fixed Height Load Carrying Truck (Fixed Platform Trucks).*

Trucks carrying its load on a non-elevating platform (*see Fig 1*).

3.1.2 *Towing and Pushing Tractor*

3.1.2.1 *Towing tractor*

Industrial truck, travelling on the ground fitted with coupling means, and specially designed to draw vehicles traveling on the ground (*see fig 2*).

3.1.2.2 *Pushing tractor*

Tractor fitted at the front end with a buffer plate and which can also push vehicles travelling on the ground or on railway trucks (*see Fig. 2*).

3.1.3 *Lift Trucks*

Industrial trucks which is capable of loading, raising and transporting loads.

3.1.3.1 *Stacking high-lift trucks*

Truck fitted with a platform, fork arms or other load handling devices, able to raise a load either palletized tiering and untiering.

- a) *Counterbalanced lift truck* — Stacking lift truck fitted with fork arms (which can be replaced by another device) on which the load, either palletized or not, is put in a cantilever position in relation to the front wheels and balanced by the mass of the truck (*see Fig. 3*)
- b) *Reach truck (with retractable mast or fork arm carriage)* — Stacking lift truck with outriggers which the load can be repositioned by moving the mast or fork arm carriage (*see Fig. 4*)

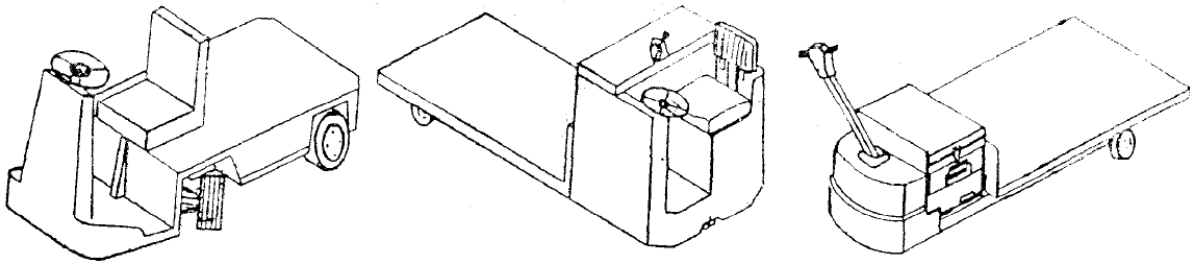

Fig. 1 Fixed Height Load Carrying Truck

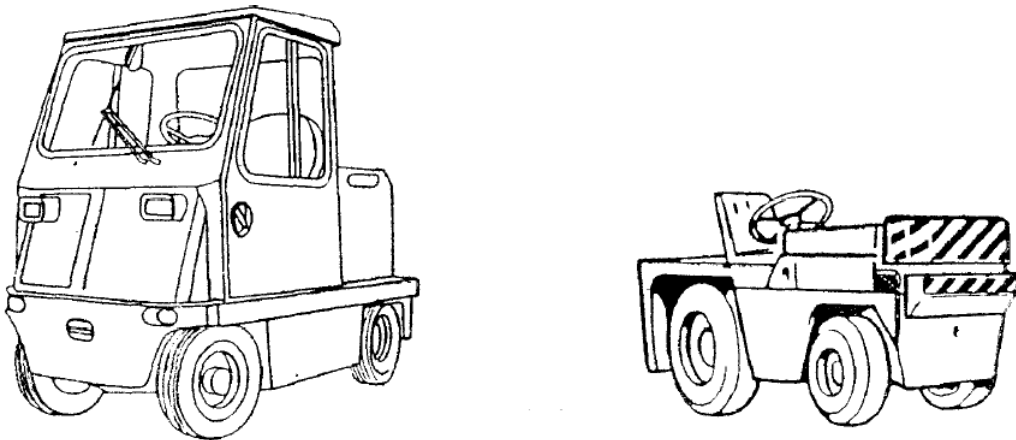

Fig. 2 Towing and Pushing Truck

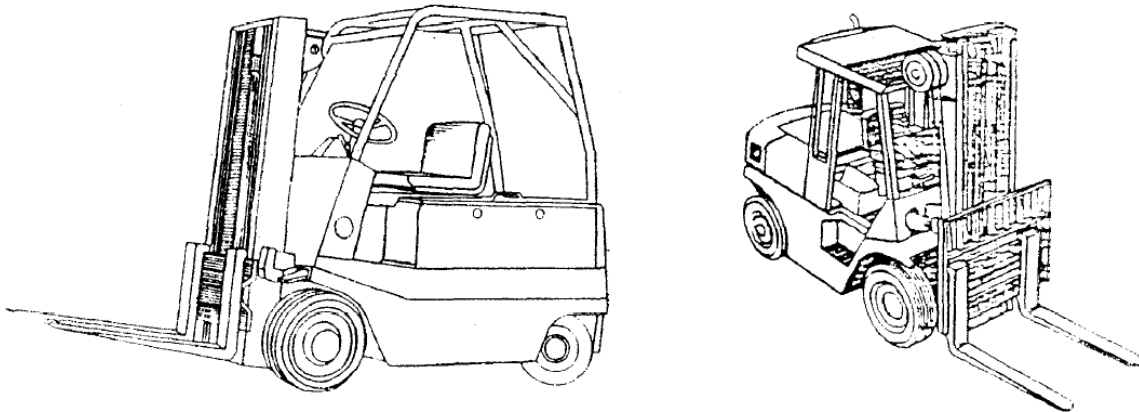
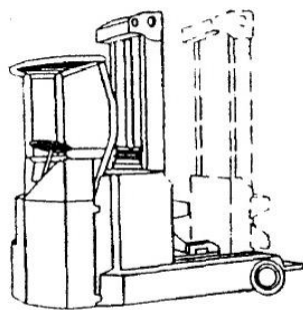
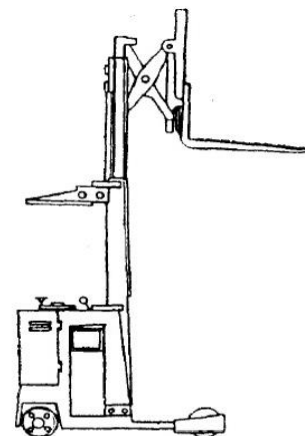

Fig. 3 Counterbalanced Lift Truck

- c) *Straddle trucks* — Stacking lift truck with outriggers, fitted with a fork, the arms of which are located between the outriggers and the centre of gravity of the load is always within the stability polygon (*see Fig. 5*).
- d) *Pallet stacking truck* — Stacking lift truck where the fork arms extend over the frame structure (*see Fig. 6*).
- e) *Platform truck* — Stacking lift truck with a load platform extending over the frame structure (*see Fig. 7*).
- f) *Truck with elevatable operating position* — Stacking lift truck, fitted with an operator's platform which can be raised with the load for tiering (*see Fig. 8*).
- g) *Side-loading truck (one side only)* — Lift truck with mast structure or fork arm carrier which can be extended and retracted between the axles and perpendicular to the longitudinal axis of the truck, allowing it to pick up and raise a load in a counterbalanced position in relating to one side of the truck and stack or unstack alongside the truck (*see Fig. 9*).
- h) *Rough terrain truck* — Wheeled counter balanced trucks, intended primarily for operation on unimproved natural terrain or disturbed terrain (*see Fig. 10*).
- j) *Lateral stacking truck (both sides)* — High lift stacking truck capable of stacking and retrieving loads on both sides of the direction of travel (*see Fig. 11*).
- k) *Lateral and front stacking truck* — High lift stacking truck capable of stacking and retrieving loads ahead and to both sides of the direction of travel (*see Fig. 12*).
- m) *Straddle carrier (high-lift type) truck* — Lift truck where the frame and lift unit straddle the load to raise, move and stack it (*see Fig. 13*).



A Retractable Mast Truck



B Retractable Fork Arm Truck

Fig. 4 Reach Truck

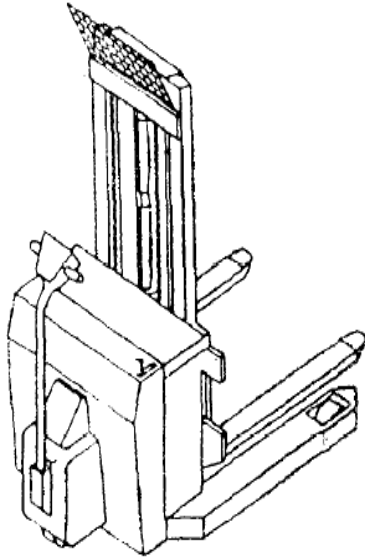

Fig. 5 Straddle Truck

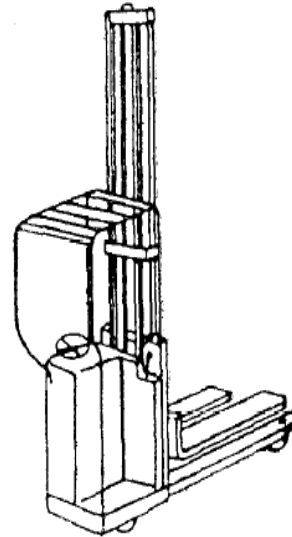

Fig. 6 Pallet Stacking Truck

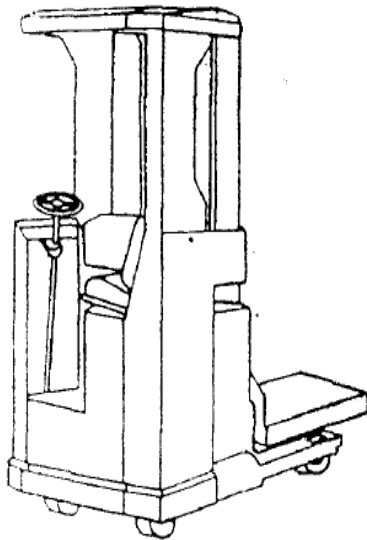

Fig. 7 Platform Truck

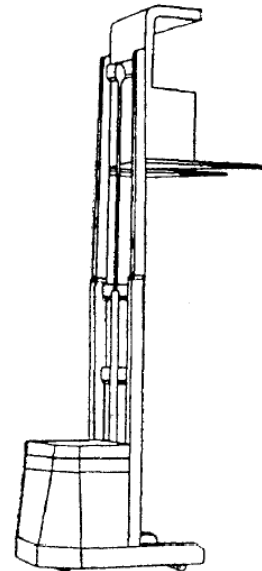

Fig. 8 Truck with Elevatable Operating Position

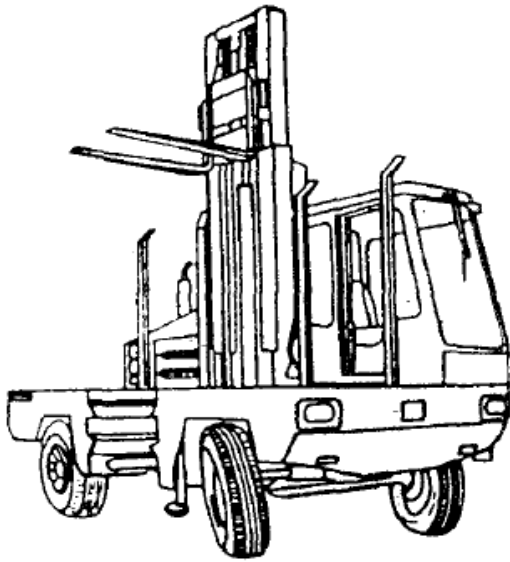

Fig. 9 Side-Loading Truck

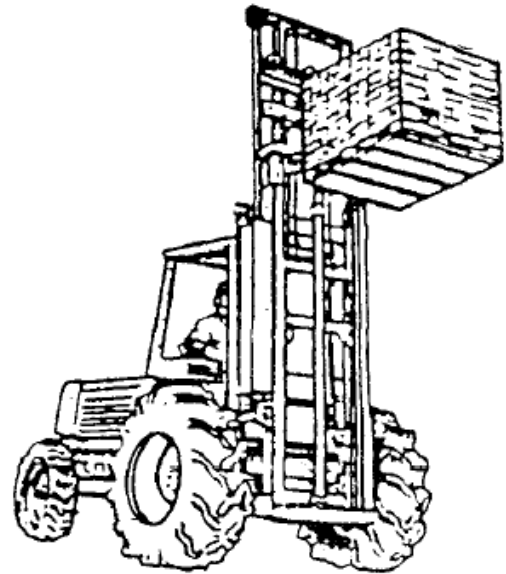

Fig. 10 Rough Terrain Truck

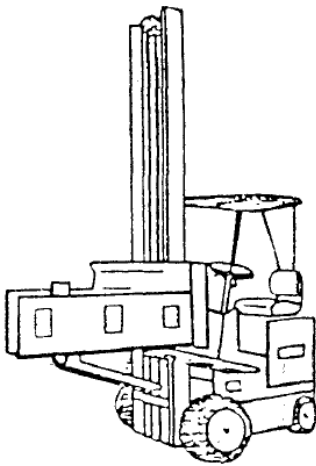

Fig. 11 Lateral Stacking Truck (Both Sides)

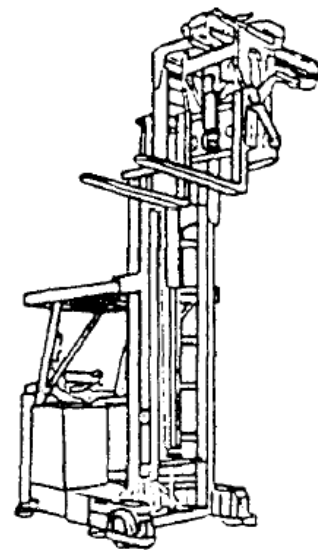

Fig. 12 Lateral and Front Stacking Truck

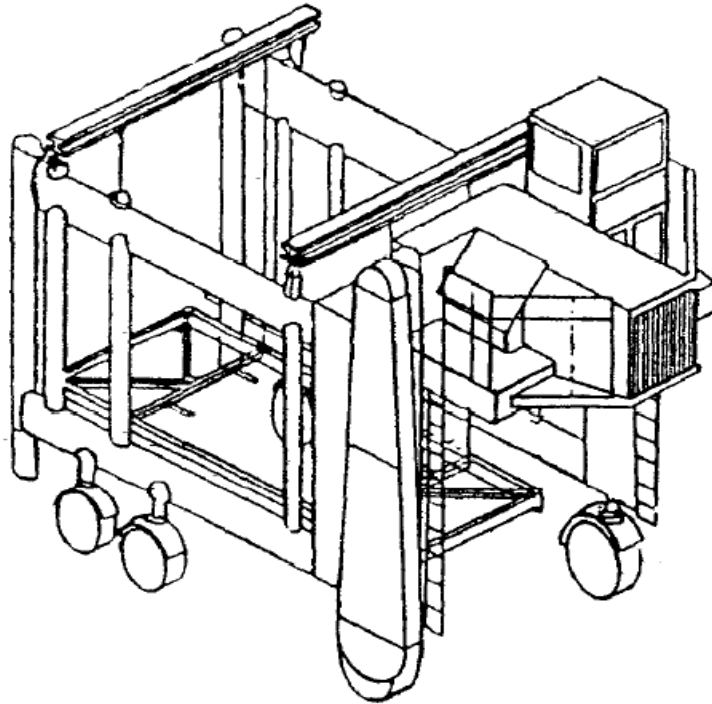

Fig. 13 Straddle Carrier (High-Lift Type) Truck

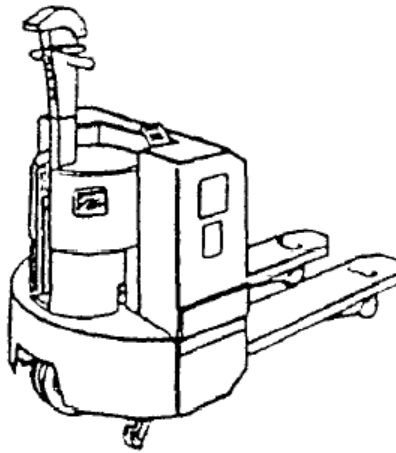

Fig. 14 Pallet Truck

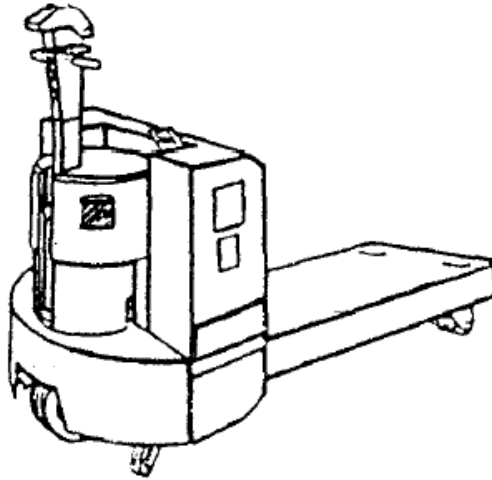

Fig. 15 Platform and Stillage Truck

3.1.3.2 *Non-stacking low-lift truck*

Truck fitted with a platform or fork arms and able to raise its load to a height just sufficient to allow its transportation.

- a) *Pallet truck* — Pedestrian or rider controlled non-stacking lift truck fitted with form arms (*see* Fig. 14).
- b) *Platform and stillage truck* — Pedestrian or rider-controlled non-stacking lift truck fitted with a load carrying platform or structure (*see* Fig. 15)
- c) *Straddle carrier (non-stacking type) truck* — Lift truck where the frame and lift unit straddle the load to raise and move it (*see* Fig. 16).

3.1.3.3 *Order picking truck*

Lift truck fitted with an operator's platform which can be raised with the platform or fork arms, allowing the operator to load or unload goods from racking to the load carrying attachment (*see* Fig. 17).

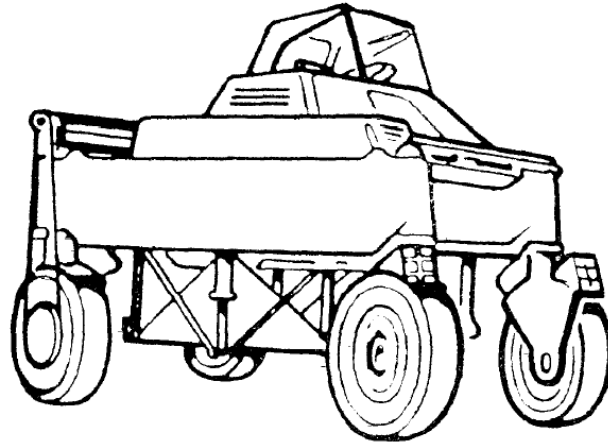
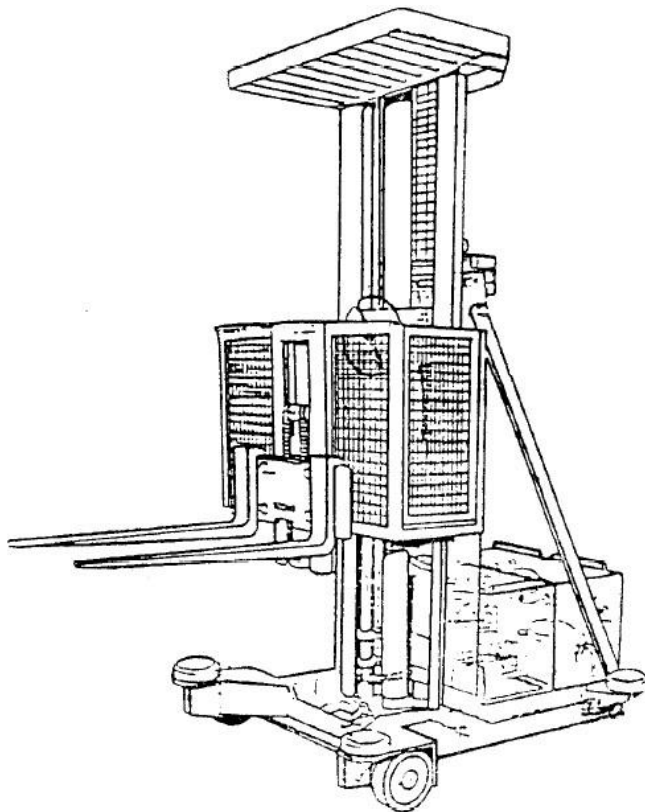

Fig. 16 Straddle Carrier (Non-Stacking Type) Truck

Fig. 17 Order Picking Truck



3.2 Classification by Power Truck

3.2.1 Internal Combustion Truck

- a) Petrol truck,
- b) Liquefied petroleum gas (LPG) truck,
- c) LPG/petrol (gasoline) truck, and
- d) Diesel truck.

3.2.2 Electric Truck

- a) Storage battery truck; and
- b) External source truck.

3.2.3 Internal Combustion, Electric Truck

3.3 Classification by Type of Wheel

- a) Wheels with pneumatic tyres
- b) Wheels with solid tyres for pneumatic tyre rims,
- c) Wheels with solid tyres, and
- d) Wheels with metal rims.

3.4 Classification by Mode of Control

3.4.1 Rider Control Truck

- a) Sit-on truck
 - i) Facing forward, and
 - ii) Other than direction of travel.
- b) Stand-on truck
 - i) Facing forward, and
 - ii) Other than direction of travel.

3.4.2 Pedestrian-Controlled Truck

3.4.3 Driverless Truck

3.5 Classification by Height of Lift

- a) Non-lifting truck,
- b) Low-lift (non-stacking) truck,
- c) Medium-lift (stacking and non-stacking)
- d) High-lift (stacking and non-stacking) truck.

3.6 Classification by Mode of Travel

3.6.1 *Free Travel*

3.6.1.1 *Uni-directional*

Movement in either direction on a line parallel with its longitudinal axis.

3.6.1.2 *Bi-directional*

Movement in either direction on a line parallel with its longitudinal axis, or perpendicular to this axis.

3.6.1.3 *Multi-directional*

Movement in any direction relative to its longitudinal axis.

3.6.2 *Guided Travel*

Movement on a line defined by external means.

3.6.3 *Dual-purpose*

Movement in any direction and optional guided travel.

4 TERMS RELATING TO COMPONENT INDUSTRIAL TRUCKS

4.1 Chassis and Associated Components

4.1.1 *Chassis*

Main frame structure to which the various units of the truck, that is engine, transmission, lifting gear, are fixed (*see Fig.18*).

4.1.2 *Counterweight*

Mass fixed to the chassis intended to counter balance the load (*see Fig. 18*).

4.1.3 *Ballast Containers*

Containers which, when filled with ballast, act as counterweights.

4.1.4 *Auxiliary Ballast Weights*

Additional masses fixed to the chassis of the truck.

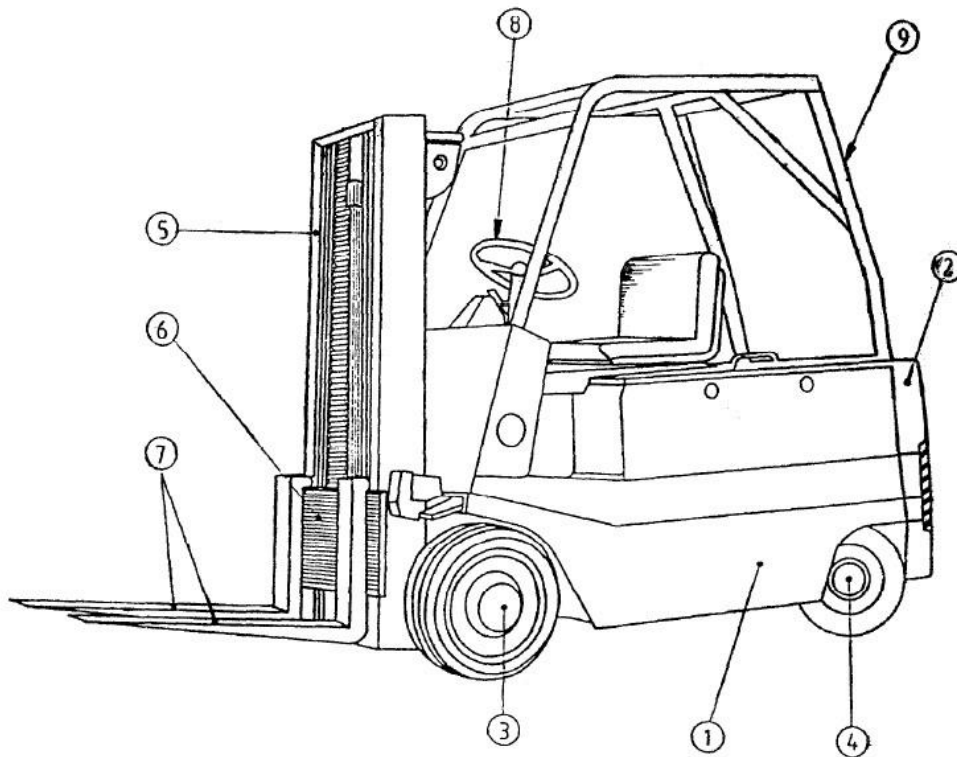

<i>Ref. No.</i>	<i>Terms</i>
1.	<i>Chassis</i>
2.	<i>Counterweight</i>
3.	<i>Drive axle</i>
4.	<i>Steer axle</i>
5.	<i>Mast</i>
6.	<i>Fork arm carrier</i>
7.	<i>Fork arms</i>
8.	<i>Steering wheel</i>
9.	<i>Overhead guard</i>

Fig. 18 Chassis and Associated Components

4.1.5 *Bodywork*

Protective or styling panels fitted to the body.

4.1.6 *Operator's Position*

Place for the operator and all the various operating controls.

4.1.1 Stabilizers

Movable components, generally in pairs, for maintaining the stability of a truck during stacking operations.

4.2 Axles

Axles are classified as follows:

- a) Drive axle (*see* Fig. 18),
- b) Steer axle (*see* Fig. 18),
- c) Drive-steer axle, and
- d) Load axle.

4.3 Driving and Steering Unit

Driving unit pivoting on the vertical axis, fitted with a single or dual wheel, used for driving and steering the truck.

4.4 Wheels [*see* IS/ISO 22877]

4.4.1 Function of Wheels

Function of wheels are as follows:

- i) Drive,
- ii) Steer,
- iii) Drive-steer,
- iv) Load, and
- v) Guide wheels.

4.4.1.2 Stabilizer wheels

Auxiliary wheels or castors, usually in pairs, solidly or resiliently mounted to the chassis of an industrial truck to assist maintaining stability.

4.4.2 Arrangement of Wheels

- a) Number of wheels at any mounting
 - i) Single wheels
 - ii) Twin Wheels
 - iii) Multiple wheels
- b) Mounting of wheels
 - i) Cantilever wheels

- ii) Fork wheels

4.4.3 Construction of Wheels

- a) Wheel made from only one material (monoblock, for example metal, plastics, rubber);
- b) Bonded tyre wheel
- c) Pressed-on tyre wheel;
- d) Split rim for removable solid tyres, flat base;
- e) Split rim for removable solid tyres, conical base; and
- f) Wheels for pneumatic tyres and pneumatic solid tyres, for pneumatic tyre rims.

4.4.4 Suspension Mountings

- a) Articulated wheels,
- b) Spring-loaded wheels,
- c) Bogie wheels, and
- d) Tandem wheels.

4.5 Other Means of Support

4.6 Power Units

- a) Electric motor,
- b) Internal combustion engine [see IS 7451 (Parts I to 6)],
- c) Petrol engine,
- d) Liquefied petroleum gas (LPG) engine.
- e) LPG/petrol engine,
- f) Diesel engine, and
- g) Dual fuel engine.

4.7 Transmission Systems

4.1.1 Hydraulic Transmission

4.7.1.1 Hydrodynamic transmission

A system in which the torque from the power unit IS transmitted by a hydraulic impeller and turbine.

4.7.1.2 Hydrostatic Transmission

A system in which torque from the power unit is transmitted by means of positive displacement hydraulic pump(s) and one (or several) motor(s).

4.7.2 Mechanical Transmission

A system in which the torque from the power unit is transmitted by direct means, that is gear, chain or belt with or without a clutch.

4.7.3 Electrical Transmission

A system in which torque from the power unit is transmitted by means of an electric generator and one or several motor(s).

4.8 Electrical Equipment

4.8.1 Electric Trucks

- a) Traction battery;
- b) Charging set (built-in or not); and
- c) Control devices (controllers, contractors, resistances, electronic control systems).

4.8.2 Engine-Powered Trucks

- a) Starter battery;
- b) Charging equipment (dynamo, alternator etc); and
- c) Starter motor.

4.8 Ancillary Electrical Equipment (for All Types of Trucks)

- a) Lighting
 - i) Driving lights (obligatory)
 - ii) Working lights
- b) Instruments
 - i) Recording (ampere/hour meter, time recorder, etc.)
 - ii) Indicating (fuel, temperature, battery discharge, etc.)
- c) Accessories (connectors, wires, etc.)

4.9 Fuel Supply System for IC Engine

- a) Supply system for petrol (gasoline)
- b) Supply system for diesel
- c) Supply system for liquefied petroleum gas (LPG)
 - i) Removable container
 - ii) Fixed container with filling valve
 - iii) Pressure reducer

- iv) Gas-air mixer (vaporizer)
- v) Valves
- vi) Safety-valves
- vii) Piping

4.10 Steering System

- a) Control elements
 - i) Wheel (*see* Fig. 18)
 - ii) Lever
 - iii) Tiller
 - iv) Oscillating platform
- b) Types of system
 - i) Mechanical system
 - ii) Hydraulic system
 - iii) Pneumatic system
 - iv) Electric system
 - v) Composite system
- c) Types of control
 - i) Manual control
 - ii) Power assisted control
 - iii) Fully assisted control

4.11 Braking System

- a) Types of brakes
 - i) Service brake
 - ii) Parking (or immobilizing) brake
 - iii) Emergency brake
- b) Types of system
 - i) Mechanical system
 - ii) Hydraulic system
 - iii) Electric system
 - iv) Pneumatic system
 - v) Composite (or power assisted) system
 - vi) Power reversal

- c) Types of control
 - i) Mechanical control
 - ii) Power assisted control
 - iii) Fully powered control

4.12 Load Bearing Attachments

4.12.1 Fork Arms (*see Fig. 18*)

- a) Hook mounted fork arms (*see IS 7570*),
- b) Shaft mounted fork arms,
- c) Bolted fork arms,
- d) Special (rotating, folding, etc.) fork arms, and
- e) Extension for the fork arms.

4.12.2 Load Platform

- a) Fixed load platform,
- b) Elevating load platform, and
- c) Tipping load platform.

4.12.3 Other Attachments

4.12.3.1 Types of attachments

- a) Attachment fixed with respect to the form carrier (crane arm, boom, etc.) or with respect to the chassis (container, tank, etc.)
- b) Load bearing attachment or part, movable with respect to the fork carrier (fork truck) or with respect to the chassis (other trucks)
 - i) Mechanical attachment (drop bottom container, scoop, etc.)
 - ii) Hydraulic attachment (clamp, side shift, rotating head, etc.)
 - iii) Pneumatic attachment (vacuum, etc.)
 - iv) Electric attachment (electro-magnet, etc.)

4.12.3.2 Modes of action of equipment

- a) Simple clamping device for engaging the load (for example stabilizer, squeeze clamp attachment)
- b) Simple equipment for engaging and imparting movement to the load (for example side shift, push-pull, rotating head)

- c) Multiple equipment (rotating clamp, etc.)

4.13 Components Associated with Movement of the Load (Excluding Travel)

4.13.1 Common Components

- a) Motor or engine, and
- b) Hydraulic components (pump, control valve, piping and accessories).

4.13.2 Lifting Assembly

4.13.2.1 Mast

A fixed upright in which the load carrier or one of several moving uprights slide (*see* Fig. 18).

- a) *Non-telescopic (simple) mast* - Mast composed only of a single pair of uprights.
- b) *Telescopic mast* - Mast composed of a fixed pair of uprights, and one or more moving upright.
 - i) *Double mast (simple telescopic)* - Mast composed of one fixed and one moving upright.
 - ii) *Triple mast* - Mast composed of one fixed upright and two moving uprights.
 - iii) *Quadruple mast* - Mast composed of one fixed upright and three moving uprights.
- c) *Lifting jack* - One or more lifting jacks (hydraulic cylinders) lifting either through chains or cables, or directly on the load carrier (or load platform) on the moving uprights.
 - i) *Simple lifting jack* - Jack with single ram used for the elevation of the load.
 - ii) *Compound lifting jack* - Jack with more than one ram arranged concentrically, which are raised one after the other.
- d) *Lifting chain (or cable)*

4.13.2.2 Articulated arms

- a) *Linkage system* - Lifting mechanism with longitudinal articulating arms, usually actuated by hydraulic jacks, to orientate the load carrier (*see* Fig. 19).
- b) *Telescopic system* - Lifting mechanism with a longitudinal telescopic and elevating arm, usually activated by hydraulic jacks, to orientate the load carrier (*see* Fig. 20).
- c) Control jacks

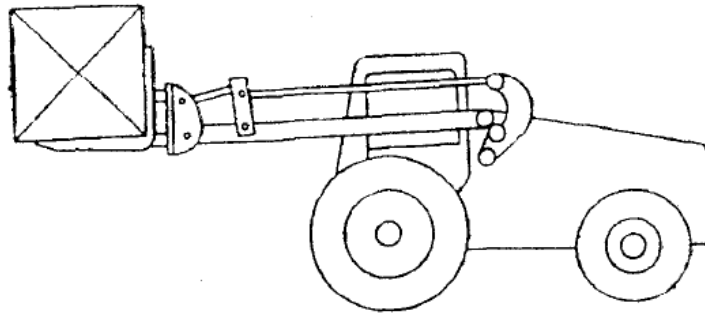

Fig. 19 Linkage System

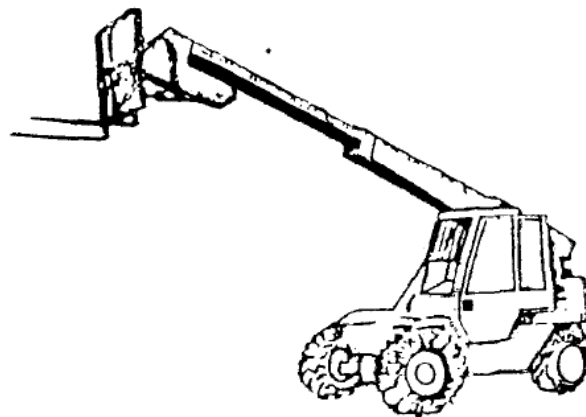

Fig. 20 Telescopic System

4.13.2.3 Other Components

- a) Fork arm carrier - Component sliding on the fixed upright in the case of a non-telescopic mast or on the last moving upright in the case of a telescopic mast and bearing the load carrying means (*see* Fig. 18);
- b) Fork arm (or other attachments);
- c) Tilting system; and
- d) Reach system.

4.13.3 Other Lifting Systems (*for example cranes on fixed height load carrying trucks*)

- a) Screw lifting system, and
- b) Winch lifting system.

5 TERMS RELATING TO INDUSTRIAL TRUCK DATA

5.1 Service Mass

Mass of a complete truck with its accessories and ready for use, that is full fuel tank for internal combustion engine trucks, traction battery for electric storage battery trucks, the truck being unladen and without driver.

5.2 Shipping Mass

Mass of the truck with its accessories, but with no source of energy on the truck, that is without fuel or traction battery.

NOTE — The word without fuel' should be understood as follows:

- a) For petrol, diesel or LPG trucks with a fixed container: with empty container;
- b) For LPG trucks with a semi-fixed container: with empty container; and
- c) For LPG trucks with a removable container: without container

5.3 Mass of the Traction Battery Unit

Mass of the battery unit, that is battery, container and ballast, if any.

5.4 Load Per Axle (Front, Rear) of the Truck in Working Order, Unladen

5.5 Load Per Axle (Front, Rear) of the Truck in Working Order with its Rated Load

5.6 Load Per Wheel (Front, Rear) of the Truck in Working Order, Unladen

5.7 Load Per Wheel (Front, Rear) of the Truck in Working Order, with its Rated Load

5.8 Truck

- a) Front (*see* Fig. 21), and
- b) Rear (*see* Fig. 21).

5.9 Wheel Base (*see* Fig. 21)

5.10 Rated Capacity and Load Diagram

5.11 Load Centre Distance

5.12 Overall Dimensions

- a) Heights
 - i) Height, mast retracted (*see* Fig. 21)
 - ii) Height, mast extended (*see* Fig. 21)

- iii) Height of overhead guard or over cab (*see* Fig. 21)
- b) Length without fork arms (*see* Fig. 21)
- c) Width (*see* Fig. 21)

5.13 Free Lift Height

Maximum height of the fork without extending the telescopic mast above the fixed mast (*see* Fig. 21).

5.14 Maximum Lift Height at Rated Load

5.15 Overall Maximum Lift Height (*see* Fig. 21)

5.16 Overhead

- a) Front overhang (*see* Fig. 21),
- b) Rear overhang (*see* Fig. 21), and
- c) Lateral overhang.

5.17 Ground Clearance under Mast (*see* Fig. 21)

5.18 Ground Clearance at Centre of Wheel-Base (*see* Fig. 21 and 22)

5.19 Ramp Angles (*see* Fig. 21 and 22)

5.20 Minimum Outside Turning

5.21 Width of Theoretical Minimum Intersecting Aisle (With and Without Load) (*see* Fig. 21)

5.22 Width of Theoretical Minimum Aisle for Right Angle Stacking (With or Without Load) (for a Given Pallet) (set Fig. 21)

5.23 Drawbar Pull

5.24 Maximum Negotiable Gradient

- a) Laden, and
- b) Unladen.

5.25 Maximum Tilt of the Mast or for Carriage

- a) Maximum tilt forward (*see* Fig. 21), and
- b) Maximum tilt backward (*see* Fig. 21).

5.26 Maximum Travel Speed on the Level (With and Without Load)

5.27 Stopping Distance

5.28 Maximum Lift Speed (With and Without Load)

5.29 Maximum Lowering Speed (With and Without Load)

6 TERMS RELATING TO SPECIFIC OPERATIONS

6.1 Engaging and Disengaging the Load

- a) Engaging and raising the load, and
- b) Lowering and disengaging the load.

6.2 Lifting and Lowering the Load

- a) Lifting the load, and
- b) Lowering the load.

6.3 Stacking/Unstacking

6.3.1 *Stacking*

Handling consisting of lifting a load, and placing it on a stack composed of similar loads.

6.3.2 *Unstacking*

Removing a load from the top most position in a stack and lowering.

6.4 Tiering/Untiering

6.4.1 *Tiering*

Handling consisting of lifting a load from a rack or shelf in a storage system.

6.4.2 *Untiering*

Handling consisting of lifting a load from a rack or shelf and lowering.

6.5 Tilting the Mast (or Fork Arms)

- a) Forward tilt, and
- b) Backward Tilt.

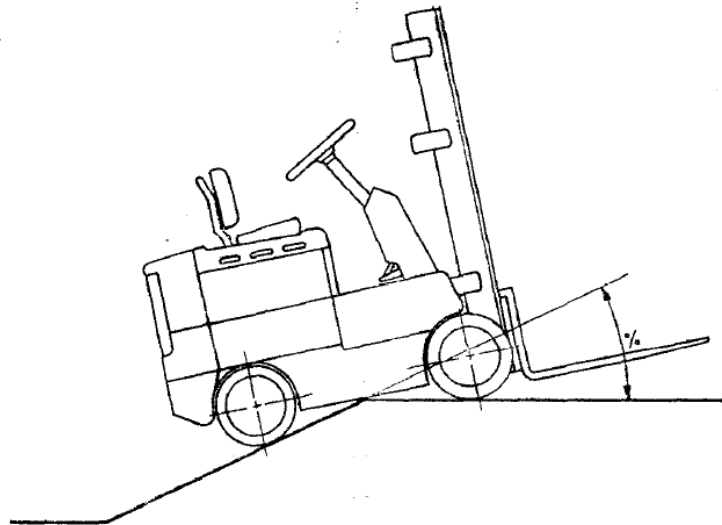

Fig. 22 Hump Clearance

6.6 Extension or Retraction of the Mast or Fork Arms

- a) Forward extension or retraction, and
- b) Lateral extension or retraction.

6.7 Travelling

6.8 Inching

Small movements of a truck, to enable a load to be positioned precisely during a handling operation for example in stacking.

6.9 Towing

6.10 Coupling /Uncoupling

- a) Coupling, and
- b) Uncoupling.

6.11 Rotating (Attachments)

6.12 Pivoting (Mass or Attachments)

Rotation of the entire lifting assembly or of a single load carrying unit about a vertical axis, to allow lateral changes to be made from the frontal position or vice versa.

6.13 Load Push/Load Pull

6.14 Side shifting

6.15 Spreading the Fork Arms (*see Fig. 21*)

6.16 Rotating (Fork Arms)

6.17 Clamping / Unclamping

6.18 Load Stabilization

6.19 Scooping / Emptying

6.20 Lowering Stabilizers/Raising Stabilizers (for One Side Loading Fork Trucks)

6.21 Tipping

6.22 Order Picking

7 TERMS RELATING TO SAFETYFEATURES

7.1 Stability

Ability of a truck, either loaded or unloaded, to resist overturning as a result of static or dynamic forces arising in service.

7.1.1 *Static Stability*

Resistance to overturning of a stationary trucks.

7.1.1.1 *Longitudinal static stability*

Resistance to overturning of a stationary trucks either forward or backward.

7.1.1.2 *Lateral static stability*

Resistance to overturning of a stationary trucks to right or left

7.1.2 *Dynamic Stability*

Resistance to overturning of a moving truck under the action of forces developed when travelling and/or handling the load.

7.1.2.1 Longitudinal dynamic stability

Resistance to overturning of a moving truck either forwards or backwards.

7.1.2.2 Lateral dynamic stability

Resistance to overturning of a moving truck to right or left.

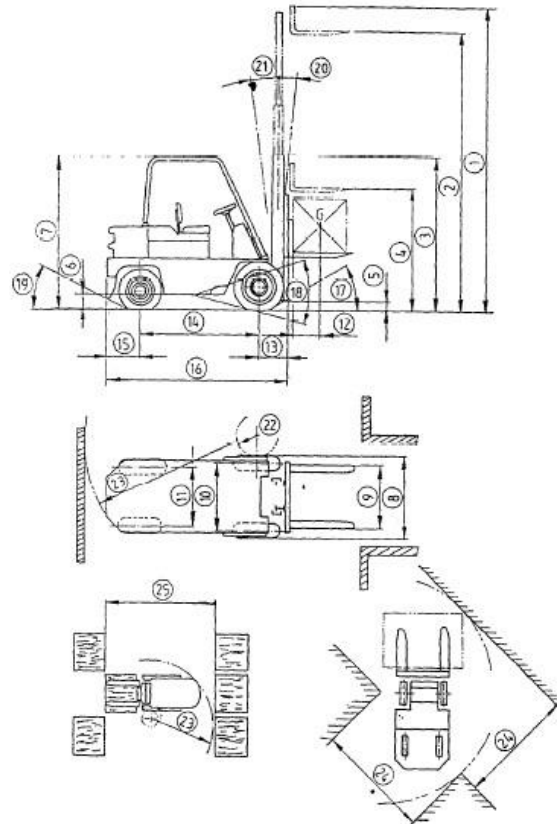

<i>Ref. No.</i>	<i>Terms</i>	<i>Ref. No.</i>	<i>Terms</i>
1.	Height mast extended	14.	Wheel base
2.	Maximum lift heights	15.	Overhang, rear
3.	Height, mast retracted	16.	Length without fork arms
4.	Free lift height	17.	Approach angle
5.	Ground clearance under mast	18.	Ramp angle
6.	Ground clearance at centre of wheel-base	19.	Departure angle
7.	Height of overhead guard or over cab	20.	Forward tilt, <i>Max</i>
8.	Overall width	21.	Backward tilt, <i>Max</i>
9.	Outside spread of fork arms	22.	Minimum inside turning radius
10.	Track, front	23.	Minimum outside turning radius
11.	Track, rear	24.	Width of theoretical minimum intersecting aisle
12.	Load centre distance	25.	Width of theoretical minimum aisle for right angle stacking (for a given pallet)
13.	Overhang, front		

Fig. 21 Terms Relating to Truck Data

7.2 Brakes

7.3 Safety Equipment

7.3.1 *Guards for Driving Position*

Complete or partial guard bordering the driving position, especially at extreme points with the object of protecting the driver frontally and/or laterally against contact with fixed obstacles or other vehicles.

7.3.2 *Overhead Guard*

Superstructure tied on the truck above the head of the driver, to protect him from objects falling from the load or the stack on which loads are being handled, or from adjacent stacks (*see* Fig. 18).

7.3.3 *Load Restrainer*

Vertical screen usually mounted on the form arm carrier to prevent any part of the load transported or handled from falling towards the operator.

7.3.4 *Spark-guard (Internal Combustion Engine)*

7.3.5 *Exhaust Gas Cooler*

7.3.6 *Exhaust Gas Purifier (for Example Catalyser)*

7.3.7 *Flame-proofing Equipment*

7.3.8 *Load Indicator*

7.3.9 *Horn*

7.3.10 *Safety Lock*

Switch to immobilize the truck, operated by a key or other means which is removed by the driver when leaving the truck unattended.

7.3.11 *Safety Switch (Seat or Pedal)*

Switch to cut off the power to a traction motor (sometimes also applying the brake), as soon as the operator ceases to exert pressure on the part actuating the switch; this may be a seat or pedal on a driver-operated truck, or the tiller of pedestrian-controlled truck.

7.3.12 *Safety Reverser*

Device located at the end of the tiller or pedestrian-controlled truck, to reverse the direction of motion when it strikes or approaches the operator (or an obstacle).

7.3.13 *Rear-view Mirror*

7.3.14 *Electrical Overload Switch*

7.3.15 *Anti-collision Device (Remote-Controlled Trucks)*

Safety device located ahead of a remote control truck, activated mechanically, optically, magnetically or by other means, which cuts off the supply current to the traction motor whilst applying the brakes.

7.3.16 *Operator Restraining Device*

Means of ensuring the safety of an operator on an order-picking truck; it may consist of safety rails to contain the operator within an enclosed area or alternatively it may be harness attached to the truck frame-work by a short length of rope or chain.

7.3.17 *Warning Lights (Flashing Beacon, Rotating Flasher etc.)*

ANNEX A
(Clause 1.3)

**TERMS RELATIXG TO INDUSTRIAL TRAILERS AND OPERATING AREAS OF
INDUSTRIAL TRUCKS**

A-1 INDUSTRIAL TRAILER

A-1.1 Industrial Trailer

Load-bearing wheeled vehicle designed to be towed on the ground by an industrial tractor or truck.

A-1.2 Non-Self-Loading Trailer

Trailer designed only for carrying, and having no loading system.

A-1.3 Self-Loading Trailer

Industrial trailer equipped with a device allowing loading and unloading without the intervention of any lifting or handling equipment.

A-2 OPERATING AREAS OF INDUSTRIAL TRUCKS

A-2.1 Working Area

Area where the truck performs loading, unloading, stacking, unstacking, tiering (in racks), untiering and associated operations.

- a) Handling at ground level, and
- b) Handling above ground level.

A-2.2 Travel Paths

- a) Tracks,
- b) Aisles, and
- c) Ramps.

A-2.2.1 Dimensions

- a) Minimum free width, and
- b) Minimum free height.

A-2.2.2 Limits of Travel Paths

A-2.2.2.1 *Marking and signals*

- a) Marking
- b) Signal - visual or auditive warning of the existence of an obstacle or hazard on the travel path

A-2.2.2.2 *Barrier*

Physical impediment to the passage of trucks or personnel.

- a) *Permanent barrier* - Barrier which is structurally secure in position.
 - 1) *Fixed barrier* - Permanent barrier which does not incorporate a means of passage.
 - 2) *Opening barrier* - Permanent barrier which incorporates a means of passage
- b) *Portable barrier* - Temporary free standing barrier.

A-2.2.3 *Doors*

- a) Manually operated doors
- b) Power operated doors

Doors operated by means of electrical, hydraulic or pneumatic power

- i) *Manual control doors* - Power operated doors responding to manual operation of a control.
 - ii) *Automatic control doors* - Power operated doors responding to the proximity of a truck.
- c) Flexible doors

Doors constructed of a material allowing opening or deformation by a traversing truck.

- a) *Hinged doors* — Flexible doors suspended on hinges.
- b) *Suspended strip doors* — Flexible doors constructed of strips of flexible material suspended from the upper beam (or lintel).

A-2.2.4 *Bridge Plate and Dockboard*

Rigid movable bearing plate ensuring continuity of a travel path between two operating areas (for example between a platform and vehicle) or allowing passage over an obstacle.

ANNEX B
(Foreword)

COMMITTEE COMPOSITION

Transport Tractors, Trailers and Industrial Trucks Sectional Committee, TED 22

Will be Added Later.