

For BIS Use Only

भारतीय मानक मसौदा

समुद्र-गामी पोतों की रक्षा-नौका, रक्षा-बेड़ा तथा बचाव-नौका के लिए संकेतन दपण – विशिष्टि
(आई एस 12264 का पहला पुनरीक्षण)

Draft Indian Standard

**SIGANLLING MIRROR FOR LIFEBOATS, LIFERAFTS AND RESCUE BOATS FOR
SEA-GOING SHIPS – SPECIFICATION**

(First Revision of IS 12264)

(ICS 47.080)

Not to be reproduced without permission
of BIS or used as standard

**Last date for receipt of
comments is 10 08 2024**

Marine Engineering and Safety Aids Sectional Committee TED 19

FOREWORD

This draft standard (First Revision) will be adopted by the Bureau of Indian Standards after the draft finalized by the Marine Engineering and Safety Aids Sectional Committee is approved by the Transport Engineering Division Council.

This standard was first published in 1987. This first revision is being undertaken to update the standard and to incorporate latest technological advancement/development that has taken place in various field. The salient features of this first revision are.

- a) The standard has been drafted as per latest drafting guidelines.
- b) Reference of revised Indian Standard has been given.
- c) Requirements and test have been modified in accordance with ISO/ DIS 18813.

d) Maintenance and inspection guidelines have been added as Annex B.

Signalling mirrors are used to signal for help over long distances. By aiming the mirror at the sun, the person in distress could signal the reflected flash of light for miles. The availability of signalling mirror on life-boat, life-raft and rescue boat is also a requirement under *Life Saving Appliances Code*.

In the formulation of this standard, assistance has been taken from ISO/ DIS 18813:2021.

Annex A and annex B are for information only.

The composition of the Committee responsible for formulation of this standard is given as Annex C (Will be added later).

For the purpose of deciding whether a particular requirement of this standard is complied with, the final value, observed or calculated, expressing the result of test or analysis, shall be rounded off in accordance with IS 2: 2022 'Rules for rounding off numerical values (*second revision*)'. The number of significant places retained in the rounded off value should be the same as that of the specified value in this standard.

1 SCOPE

This standard specifies material, general constructional requirements and testing of signalling mirrors available on lifeboat, life rafts and rescue boats of sea-going vessels.

2 REFERENCES

The following Indian Standard is necessary adjuncts to this standard. At the time of publication, the edition indicated was valid. All standards are subject to revision, and parties to agreements based on this standard are encouraged to investigate the possibility of applying the most recent editions of the standards indicated below:

<i>IS No.</i>	<i>Title</i>
6911 : 2017	Stainless steel plate, sheet and strip - Specification (<i>Second Revision</i>)
7328 : 2020	Specification for Polyethylene Material for Molding and Extrusion (<i>Third Revision</i>)
1260 (Part 2) : 2020	Packaging — Distribution Packaging — Graphical Symbols for Handling and Storage of Packages Part 2 General Good (Fourth Revision)

9536 : 1989

Polyamide cord – Specification (*first revision*)

3 MATERIAL

3.1 The parts of the mirror may be manufactured from the materials recommended in Table 1.

Table 1 Requirement of Materials
(*Clause 3.1*)

Name of the part	Material/ Grade
Mirror	Steel 04Cr18Ni10Ti conforming to IS 6911
Spoon	Polyethylene conforming to IS 7328
Thread	Nylon conforming to IS 9536

4 DIMENSIONS

The recommended shape and dimension of the signaling mirror is give in Fig.1.

5 GENERAL CONSTRUCTION REQUIREMENTS

5.1 Mirror

The signalling mirror shall be of metal, plastic, or glass with a smooth, even, and unpitted reflecting surface.

5.1.1 Metal mirrors with a base of corrodible metal shall be plated over the base with copper, and upon that a plating of nickel with a final coating of chromium. Plating shall be done after all stamping, cutting, and grinding is completed.

5.1.2 The reflecting area of plastic or glass mirrors shall be by deposition of either aluminium or silver. The rear of the reflecting area and edges shall be adequately protected from corrosion by a durable protective coating. Glass, if used, shall be tempered.

5.2 Lanyard

A lanyard shall be securely attached to each mirror by means of a hole. The lanyard shall be approximately 1 m long and in the form of a 0.5 m loop. The dry breaking strength of the lanyard shall be 220 N *Min.*

5.3 Mirror

5.3.1 The mirror shall be flat, with a reflecting area of at least 110 cm^2 , and of such thickness that it cannot be easily deformed in use. Any corners shall be rounded. At the centre of the mirror there shall be an effective aiming means of optical quality such that a person of normal vision can observe a distant small signalling target through it.

5.3.2 A wiping cloth to remove finger and hand stains, of twice the area of one mirror, shall be included with the mirror.

5.3.3 Weight of the signalling mirror shall not exceed 0.25 kg.

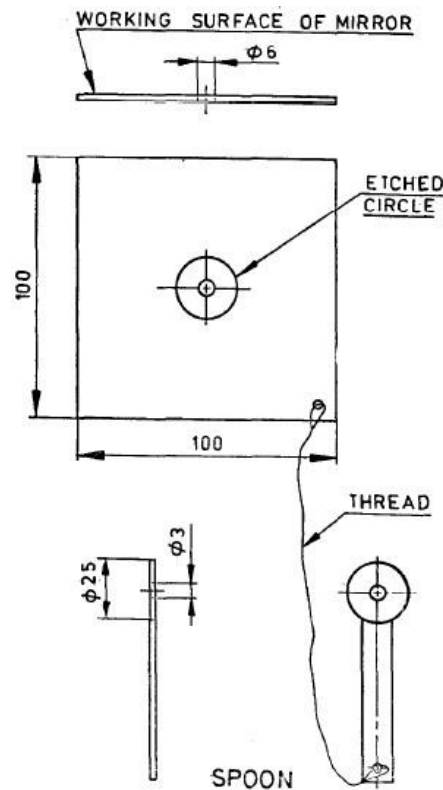

All dimensions in millimetres.
FIG. 1 SIGNALLING MIRROR

6 TESTING

6.1 Reflection Test

The reflected intensity of the mirror shall be measured in a dark room at a distance 2 m using a standard lamp and intensity-meter. The reflectance shall be 80 percent *Min.*

6.2 Flatness Test

The area and shape of a reflected beam of sunlight on a surface 2 m from the mirror shall be measured. The shape and area of the reflected beam on the wall shall be same as that of the mirror.

6.3 Oil Resistance Test

The mirror shall be submerged in petrol for 24 h. No visible deformation, defect or other change shall be observed after mirror is taken out.

6.4 Drop Test

The mirror shall be dropped from a height of 2 m on a hardwood board 25 mm thick, secured to a concrete floor, in such a position that the reflecting surface strikes the board. Repeat the test with the mirror positioned so as to strike the back and two different corners. The mirror shall not break after the drop.

6.5 Lanyard Strength Test

The tensile strength of the lanyard shall be measured at a displacement speed of 200 mm/min for 100 mm length. The test should be performed using five test pieces. The breaking strength shall be 220 N *Min.*

7 PACKING

7.1 Each mirror, together with the lanyards and operating instructions as specified in **8.2** shall be packed in a single durable watertight container enclosed within an outer durable container.

8 MARKING

8.1 Each signaling mirror outer container shall be marked with the following:

- a) SIGNALLING MIRROR; and
- b) Name of the manufacturer.

8.2 Appropriate instructions for the mirror type shall be printed on waterproof paper in text at least 3 mm high, or permanently affixed to the back of the mirror, and shall include diagrams illustrating the use of the mirror.

8.3 BIS Certification Marking

The signaling mirror may also be marked with the Standard Mark.

8.3.1 The product(s) conforming to the requirements of this standard may be certified as per the conformity assessment schemes under the provisions of the *Bureau of Indian Standards Act, 2016* and the Rules and Regulations framed thereunder, and the product(s) may be marked with the Standard Mark.

9 SAMPLING

Unless otherwise agreed upon between a supplier and purchaser, the inspection sampling shall be as per IS 2500 (Part 1).

ANNEX A
(Informative)

INSTRUCTIONS FOR USE OF SIGNALLING MIRROR

A-1. Hold the mirror in one hand and the spoon in the other, about 300 mm away as shown in Fig. 2.

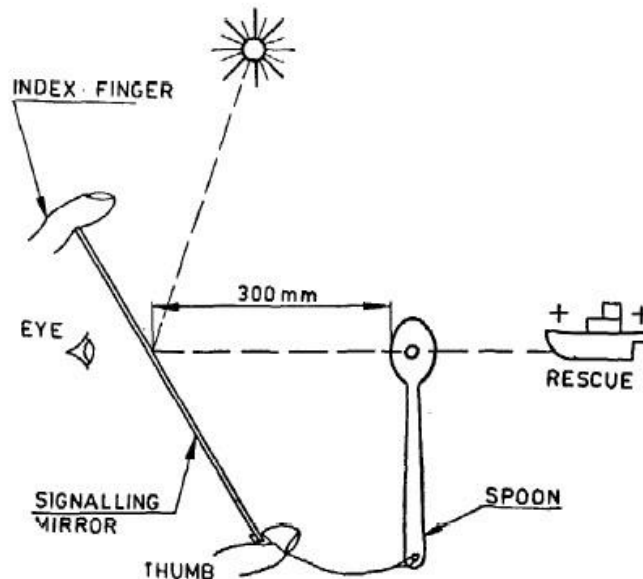

FIG. 2 USE OF SIGNALLING MIRROR

A-2 Stand facing towards the sun. The working surface of the mirror shall be turned towards the sun.

A- 3 Obtain the shade of the center hole in the mirror on the hole in the spoon.

A- 4 Align eye, the hole in the mirror and the hole in the spoon and aim towards the rescue plane or ship or person whose attention is to be attracted.

ANNEX B
(Informative)

MAINTENANCE AND PERIODIC INSPECTION GUIDELINES

The signalling mirror package should not be opened for inspection. If the sealed package is intact, if there is no indication that the mirror is broken and if the package markings are legible, the mirror should be considered acceptable for continued use

ANNEX C
(Foreword)

COMMITTEE COMPOSITION