

For Comments only

DRAFT *INDIAN STANDARD*

SHEAVES USED WITH SHIPS' BLOCKS — SPECIFICATION

(*First Revision of IS 6143*)

(ICS No. 47.020.40; 53.020.30)

**Not to be reproduced without permission
of BIS or used as an Indian Standard**

**Last date for receipt
of comments is 12 06 2024**

Shipbuilding Sectional Committee, TED 17

FOREWORD

This draft Indian Standard (First Revision) will be adopted by the Bureau of Indian Standards after the draft finalized by the Shipbuilding Sectional Committee is approved by the Transport Engineering Division Council.

This standard was first published in 1971. This first revision is being undertaken to update the standard and to incorporate latest technological advancement/ development that has taken place in various fields. The salient features of this first revision are:

- a) The standard has been drafted as per latest drafting guidelines.
- b) Reference to Indian Standard has been updated
- c) Grades of material have been updated.

Ship's blocks for wire rope are used in various positions with the cargo handling gear and other general purpose work on ships. The blocks used on ships are to be tested for proof loads as specified in the Dock Workers (Safety, Health and Welfare) Regulations, 1990, which is in accordance with the ILO convention.

This standard generally covers the regulations for the testing of cargo handling appliances specified by the Classification Societies.

Ship's blocks using wire ropes are permitted to be used only as deck lead blocks, or as span blocks single or double reeved for topping the unloaded derrick. In addition, they can also be used as lead blocks, for guy tackle runners, if the runners are turned round to an angle of not more than 90°.

The composition of the Committee responsible for the formulation of this standard is given at Annex A (Will be added later).

For the purpose of deciding whether a particular requirement of this standard is complied with, the final value, observed or calculated, expressing the result of test or analysis, shall be rounded off in accordance with IS 2: 2022 ‘Rules for rounding off numerical values (*second revision*)’. The number of significant places retained in the rounded off value should be the same as that of the specified value in this standard.

1 SCOPE

This standard specifies the material and dimensions of sheaves used with ships’ blocks of nominal sizes 1 to 12.

2 REFERENCES

The following standards contain provisions which through reference in this text, constitute provision of this standard. At the time of publication, the editions indicated were valid. All standards are subject to revision, and parties to agreements based on this standard are encouraged to investigate the possibility of applying the most recent editions of the standard indicated below:

<i>IS No.</i>	<i>Title</i>
IS 210 : 2009	Grey iron castings — Specification (<i>fifth revision</i>)
IS 318 : 1981	Specification for leaded tin bronze ingots and castings (<i>second revision</i>)
IS 1030 : 1998	Carbon steel castings for general engineering purposes – Specification (Fifth Revision)
IS 1570 (Part 2) : 1979	Schedule for wrought steels : Part 2: Carbon steels (Unalloyed steels) (<i>second revision</i>)
IS 1865 : 1991	Iron castings with spheroidal or nodular graphite - Specification (Third Revision)
IS 2102 (Part 1) : 1993	General tolerances: Part 1 tolerances for linear and angular dimensions without individual tolerance indications (Third Revision)
IS 2581 : 2002	Round strand galvanized steel wire ropes for shipping purposes — Specification (<i>fourth revision</i>)
IS 14329 : 1995	Malleable iron castings - Specification

3 TERMINOLOGY

For the purpose of this standard, the following definition shall apply.

3.1 Nominal Size — Safe working load in tonnes of the block with which the sheave is used, is the nominal size of the sheave.

4 TYPE

4.1 Sheaves are classified as Types A and Type B.

4.2 Type B is further classified as Type B1, Type B2 and Type B3 respectively.

5 GENERAL

5.1. The diameter of the sheave measured at the bottom of the groove shall be at least nine times of the diameter of the appropriate rope for Type A and 14 times for Type B respectively. Wire rope shall be of construction 6×19 M (12/6-1) conforming to IS 2581.

5.2 The radius of the groove shall be about 1 mm more than the radius of the rope used, to ensure that the rope lies properly at the bottom of the groove. If the groove is too wide, the rope would, owing to the pull, become flattened and its wear will be considerably increased. The angle formed by the sides of the grooves should vary from 30 to 45°. The depth of the groove is approximately equal to the diameter of the rope used. The nominal strength of rope used shall be taken as 130 kN/ cm² even if ropes of greater nominal strength are used.

5.3 The bush for Types A and Type B1 are similar (see figure 5). A number of holes are drilled in the bush for lubrication.

5.4 Three equally spaced grooves are provided in the bush of Type B2 and Type B3 respectively for receiving the leather pieces. The oil passages are located differently, in Types B2 and B3 as shown in figure in Fig. 3 and 4 respectively.

5.5 The bush shall be force fit in the boss of the sheave.

6 MATERIAL

6.1 The material used for the manufacture of sheave and bush shall be as given below:

SI No.	PART	Material Conforming to
i)	Casing	i) Grade FG 260 of IS 210; or ii) Grade SG 400/18 of IS 1865; or iii) Grade 20C8 of IS 1570 (Part 2); or iv) IS 1030; or v) IS 14329.
ii)	Bush	Grade LTB 2 of IS 318

7 DIMENSIONS

7.1 The dimensions for Types A and Type B shall be as shown in Tables 1 and 2 respectively.

7.2 The dimensions for the bush shall be as shown in Table 3.

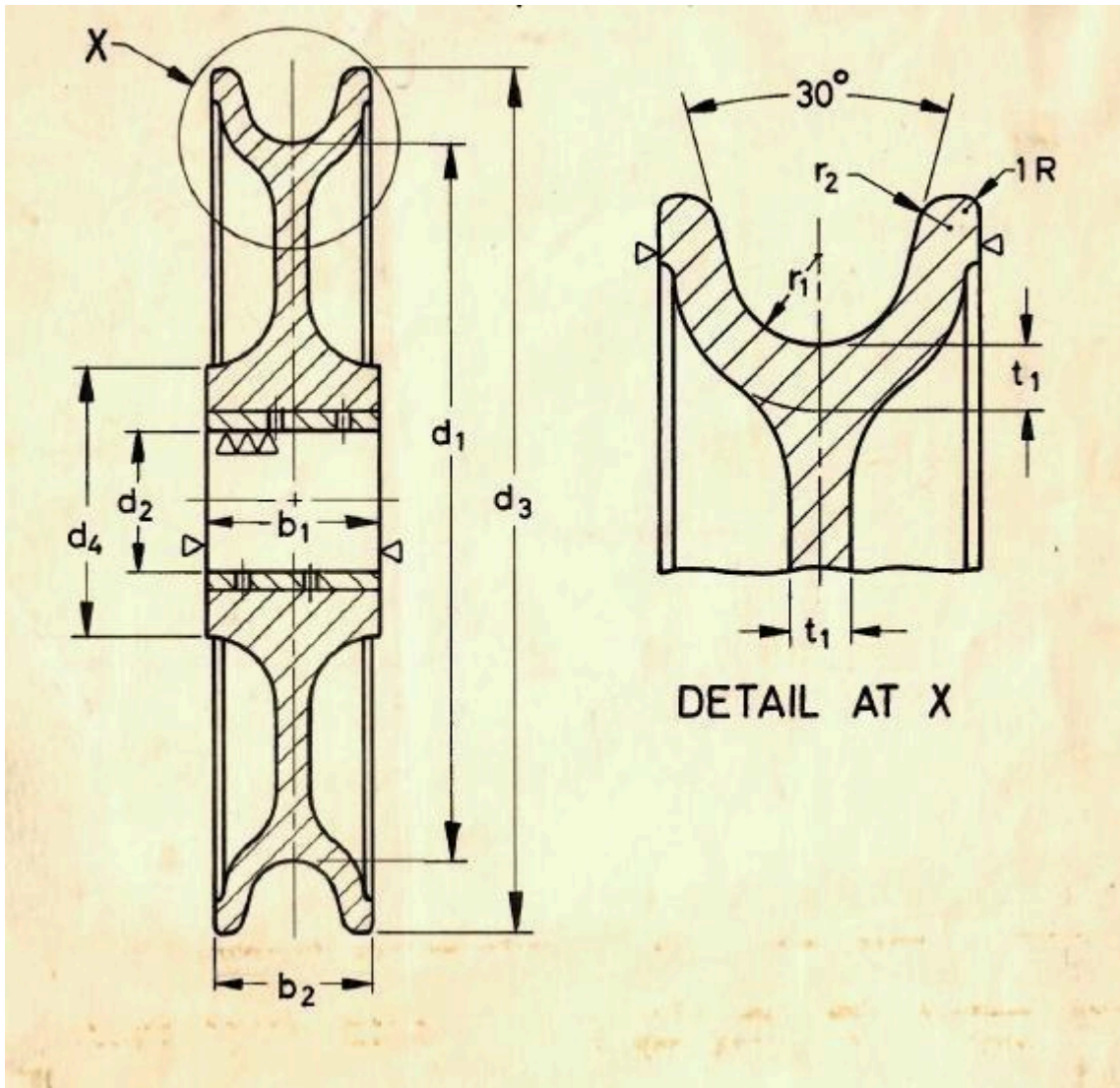

Fig.1 Sheave of Type A

Table 1 Dimensions for Type A Sheaves
 (Clauses 7.1, 8.1 and 8.2)

Nominal Size of Sheave	*Wire Rope Dia	b_1 h13	b_2 h13	d_1	d_2 C11	d_3	d_4	r_1 ± 0.5	r_2 Approx	t_1	
										Cast Iron	Other† Material
(1)	(2)	(3)	(4)	(5)	(6)	(7)	(8)	(9)	(10)	(11)	(12)
1	12	27	25	112	22	135	42	7	2.5	7	5
2	16	34	32	150	32	180	56	9	2.5	8	6
3	20	42	40	180	40	220	70	11	4.0	9	6
4	22	48	46	215	45	260	80	12	5.0	9	7
5	24	54	52	235	50	290	85	13	6.0	10	7
6	28	60	58	270	55	330	96	15	6.0	11	8
8	32	67	64	300	65	365	105	17	6.0	12	9
10	36	75	72	325	70	400	120	19	8.0	14	10
12	40	83	80	360	80	440	125	21	8.0	16	12

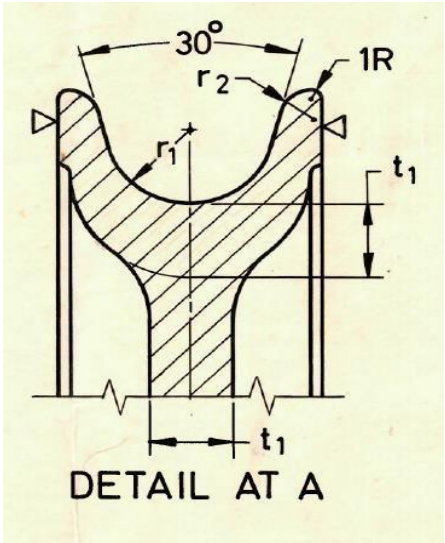
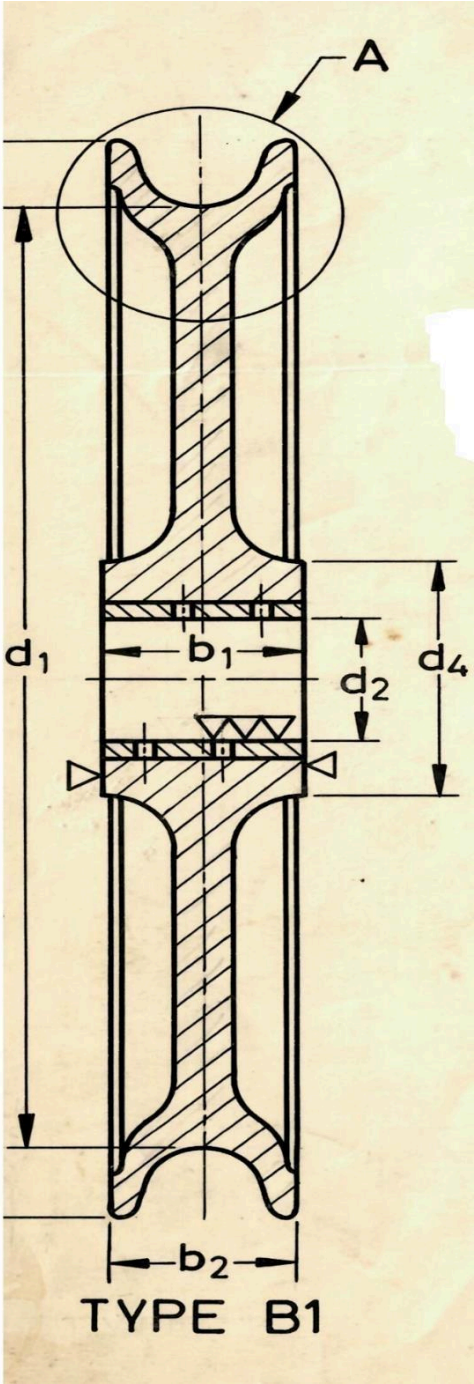

Fig.2 Sheave of Type B1`

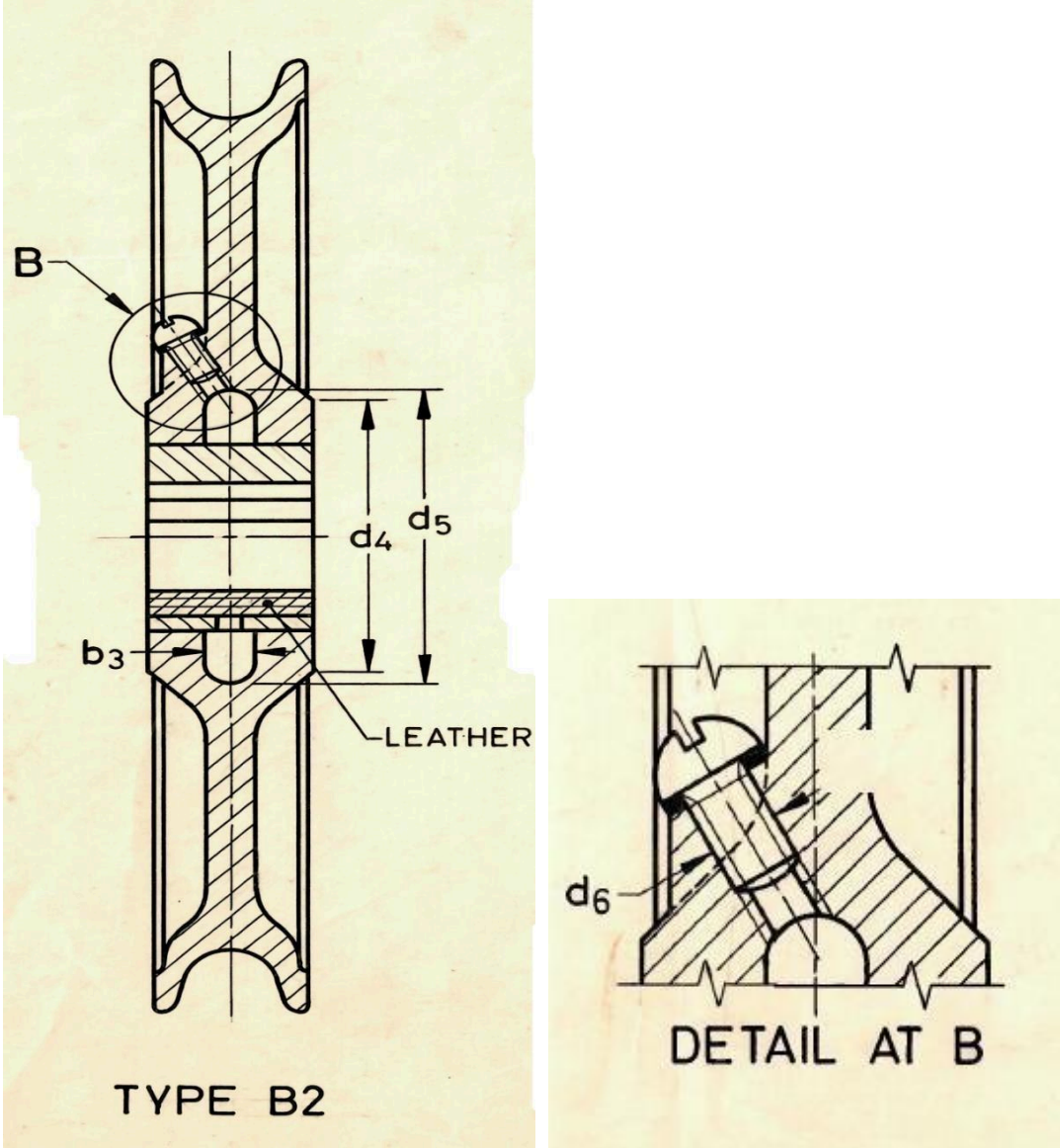

Fig.3 Sheave of Type B2

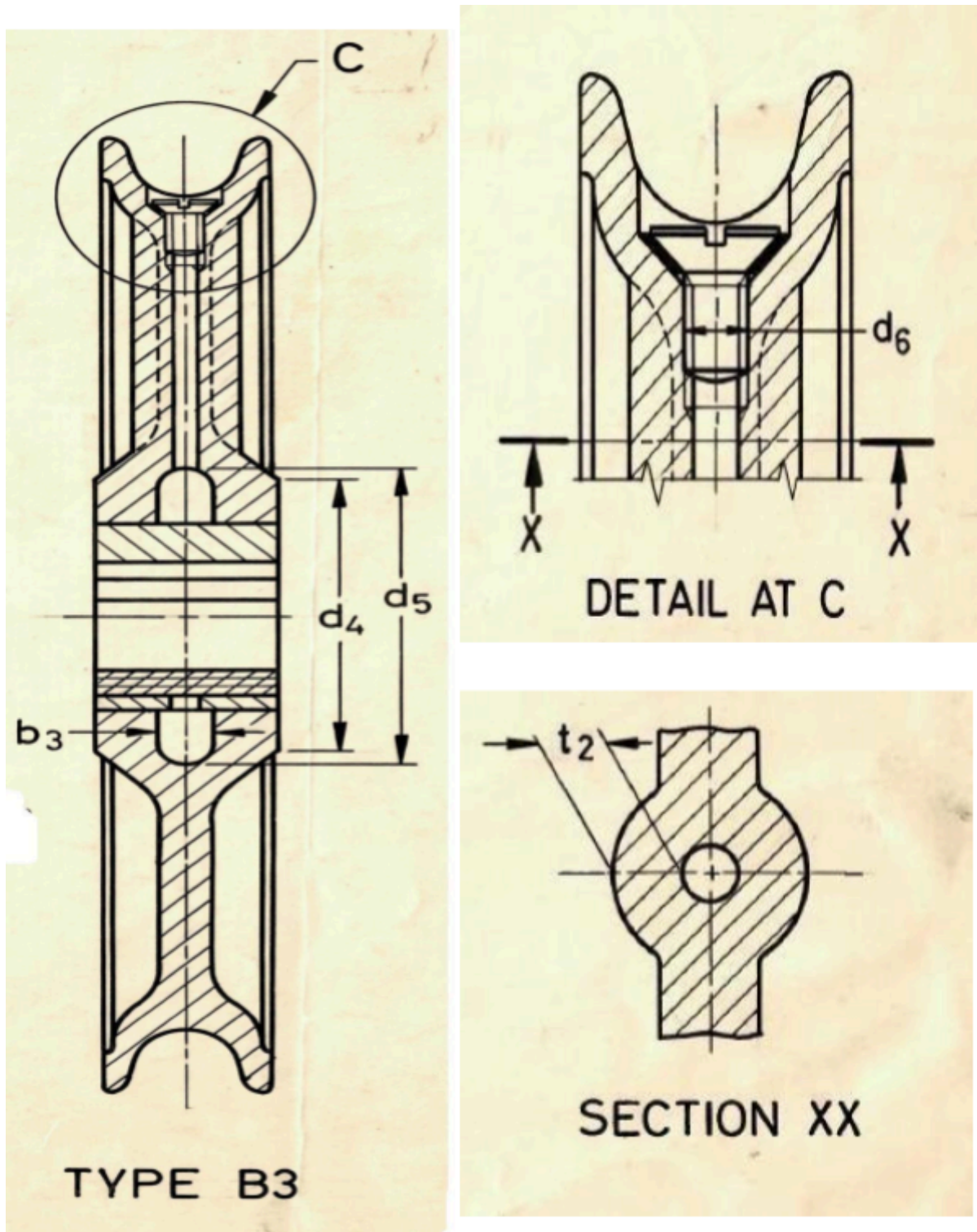

Fig.4 Sheave of Type B3

Table 2 Dimensions for Type B1, B2 and B3 Sheaves
(Clauses 7.1, 8.1 and 8.2)

Nominal Size of Sheave	*Wire Rope Dia	b_1 h13	b_2 h13	b_3	d_1 C11	d_2	d_3	d_4		d_5	d_6	r_1 ± 0.5	r_2 Approx	t		t_2 Approx
								Type B1 (9)	Types B2 and B3 (10) (11)					Cast Iro n (15)	Other† Materia l (16)	
(1)	(2)	(3)	(4)	(5)	(6)	(7)	(8)	(9)	(10)	(11)	(12)	(13)	(14)	(15)	(16)	(17)
1	12	27	25	8	170	22	195	42	55	60	M6	8	3	8	5	6
2	16	34	32	10	225	32	260	55	70	75	M6	10	3	9	6	7
3	18	42	40	14	255	40	295	70	85	90	M8	11	4	10	7	8
4	20	48	46	15	280	45	320	80	95	100	M8	12	4	11	8	8
5	22	54	52	16	318	50	360	85	100	115	M8	13	4	12	9	9
6	24	60	58	18	375	55	430	95	110	125	M8	15	5	13	10	9
8	28	67	64	20	400	65	460	105	120	135	M10	16	6	14	11	10
10	32	75	72	22	450	70	515	115	130	145	M12	18	8	14	11	10
12	36	83	80	22	505	80	580	125	140	155	M12	20	8	16	12	11

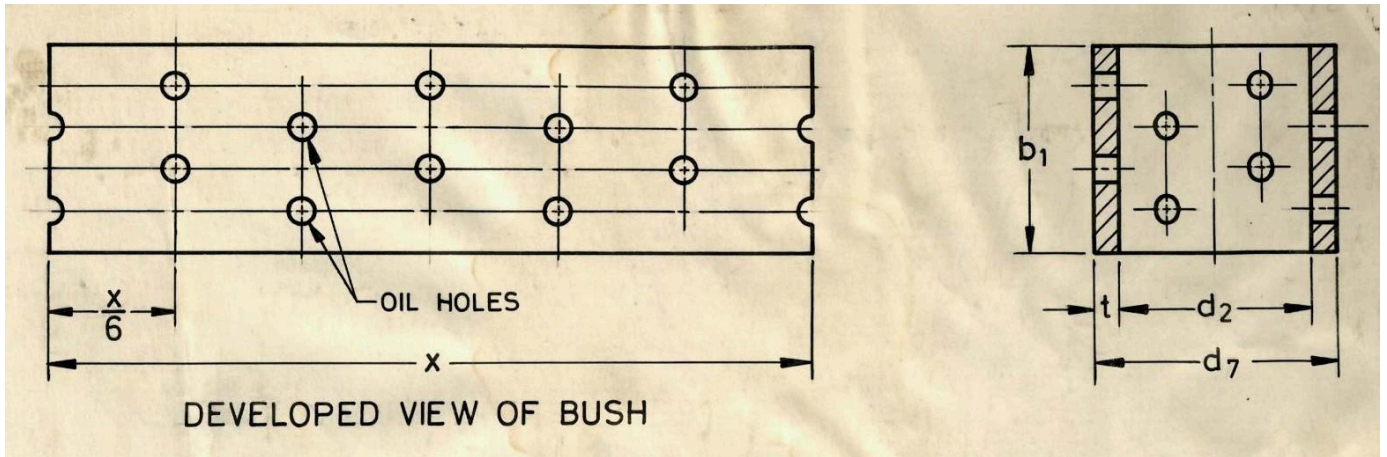

Fig.5 Bush for Type A and Type B1 Sheaves

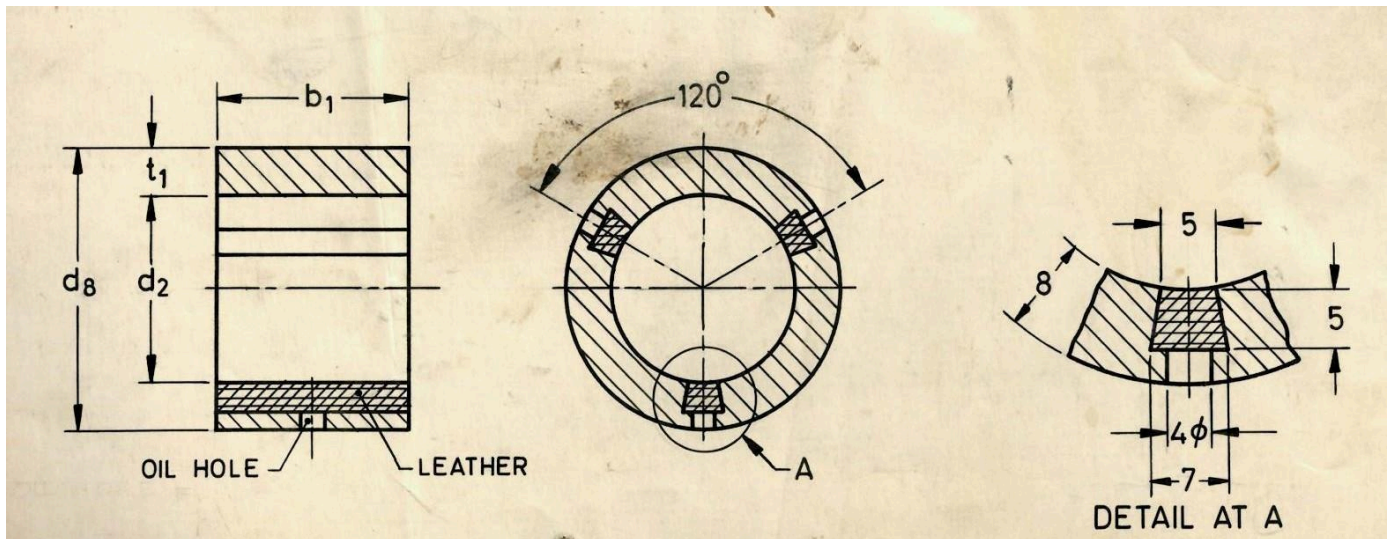

Fig. 6 Bush for Type B2 and Type B3 Sheaves

Table 3 Dimensions for Bushes for Sheaves
(Clauses 7.2 and 8.1)

d_2	d_7	d_8	t	t_1
H7	r6	r6		
(1)	(2)	(3)	(4)	(5)
22	28	38	3	8
32	40	48	4	8
40	50	56	5	8
45	55	61	5	8
50	60	66	5	8
55	67	71	6	8
65	80	81	7.5	8
70	85	86	7.5	8
80	100	100	10	8

NOTE — See Table 2 for dimension b_1 .

8 TOLERANCES

8.1 The tolerance for certain dimensions are shown in Tables 1, 2 and 3. The tolerance on other dimensions shall be coarse deviation according to IS 2102 (Part 1).

8.2 There shall be no negative tolerance on dimension t_1 , in Tables 1 and 2.

ANNEX A
(Foreword)

COMMITTEE COMPOSITION

SHIPBUILDING SECTIONAL COMMITTEE, TED 17

(Will be added later)