

For Comments Only

BUREAU OF INDIAN STANDARDS

DRAFT FOR COMMENTS ONLY

(Not to be reproduced without the permission of BIS or used as an Indian Standard)

भारतीय मानक मसौदा

साइकिल — पैडल समुच्चय — विशिष्टि

(आई एस 628 का तीसरा पुनरीक्षण)

Draft Indian Standard

BICYCLES – PEDAL ASSEMBLY – SPECIFICATION

(Third Revision of IS 628)

ICS 43.150

Bicycles Sectional Committee, TED 16

**Last date for receipt of comments is
03/03/2024**

FOREWORD

(Formal clause will be added later)

This standard was initially published in 1955 and revised in 1963 and 1993. In this revision, following significant changes have been made:

- More choices of materials have been allowed;
- More number of shapes have been included; and
- New tests such as durability test, Impact test and Toxicity test have been specified.

The composition of the Committee responsible for the formulation of this standard is given in **Annex B. Will be add later**

For the purpose of deciding whether a particular requirement of this Standard has complied with the final value, observed or calculated, expressing the result of a test or analysis shall be rounded off as per IS 2 : 2022 Rules for rounding off numerical values (*Second revision*). The number of significant places retained in the rounded-off value should be the same as that of the specified value in this Standard.

Draft Indian Standard

BICYCLES – PEDAL ASSEMBLY – SPECIFICATION

(*Third Revision*)

1 SCOPE

This standard prescribes the requirements for pedal assembly suitable for fitting in bicycles for general use.

2 REFERENCES

The following standards contain provisions, which through reference in this text, constitute provisions of this standard. At the time of publication, the editions indicated were valid. All standards are subject to revision and parties to agreements based on this standard are encouraged to investigate the possibility of applying the most recent editions of the standards indicated below.

<i>IS No.</i>	<i>Title</i>
1068: 1993	Electroplated coatings of nickel plus chromium and copper plus nickel plus chromium on iron and steel (third revision)
1570-4: 1988	Schedules for wrought steels: Part 4 alloy steels (Alloy Constructional and Spring Steels) with specified chemical composition and mechanical properties (<i>first revision</i>)
1572: 1986	Electroplated coatings of cadmium on iron and steel (<i>second revision</i>)
1573: 1986	Electroplated coating of zinc on iron and steel (<i>second revision</i>)
2898 (Part 1): 2019/ ISO 3290-1: 2014	Rolling bearings -- Balls: Part 1 Steel balls (<i>second revision</i>)
4398: 1994	Carbon - Chromium steel for the manufacture of balls, rollers and bearing races - Specification (<i>second revision</i>)
ISO 6742-2: 2023	Cycles Lighting and retro-reflective device. Part 2: Retro-reflective device
10613: 2023	Cycles - Safety and performance requirements for bicycles (<i>third revision</i>)
DOC: TED 16 (18837)	BMX bicycles – Safety requirements and test methods
DOC: TED 16 (23113)	Cycles - Safety requirements for bicycles for young children (<i>second revision</i> of IS 15533:2018/ISO 8098: 2014)
DOC: TED 16 (23339)	Cycles — Electrically power-assisted cycles (EPAC): Part 1 Pedal-Assisted Bicycles

3 MATERIALS

3.1 The components of the pedal assembly may be made from any suitable material subject to its conformity with tests specified in this standard. The commonly used materials for spindle or axle are Steel, Cr-Mo Steel. Stainless Steel and Titanium alloy are the commonly used materials for body. For platform the commonly used materials are Stainless Steel, Aluminium alloy, Forged alloy, Composites or Synthetic Plastic, and Rubber.

3.2 Components of the pedal assembly which are subjected to friction such as ball races and spindle shall have a minimum hardness of 600 HV (with 5 kgf load) on the wearing surfaces.

3.3 Balls, if made of steel, shall conform to grade 105Cr5 of IS 1570 (Part 4) or Grade 103Cr4 of IS 4398. The finished balls shall conform to grade 200 of IS 2898 part 1. These shall be heat treated to achieve hardness between 708 HV to 890 HV (with 5 kgf load). These shall be spherical and uniform in size.

The manufacturers may use any other suitable material for balls subject to their conformity with tests specified in this standard.

3.4 If ceramic balls are used, they shall conform to the grade Si₃N₄ (Silicon Nitride) or its equivalent. The finished balls shall conform to grade 5 of IS 2898 part 2. These shall be heat treated (hot isostatic pressed) to achieve hardness between 78 HRC to 83 HRC (with 150 kgf load). These shall be spherical and uniform in size.

4 SHAPES AND DIMENSIONS

4.1 The pedal spindle shall conform to the dimensions given in Fig. 1, Fig. 2 and Table 1. Other components shall be made to suit the spindle size (see Fig. 3, Fig. 4, Fig. 5).

4.2 Some common shapes of pedal are given in Fig. 3, Fig. 4 and Fig. 5.

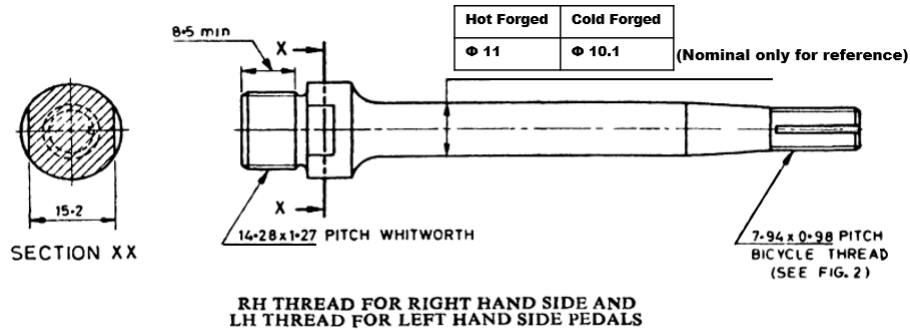

NOTE — The left hand side pedals shall either be stamped LH or suitably knurled to indicate LH thread.

All dimensions in millimetres.

FIG. 1 PEDAL SPINDLE

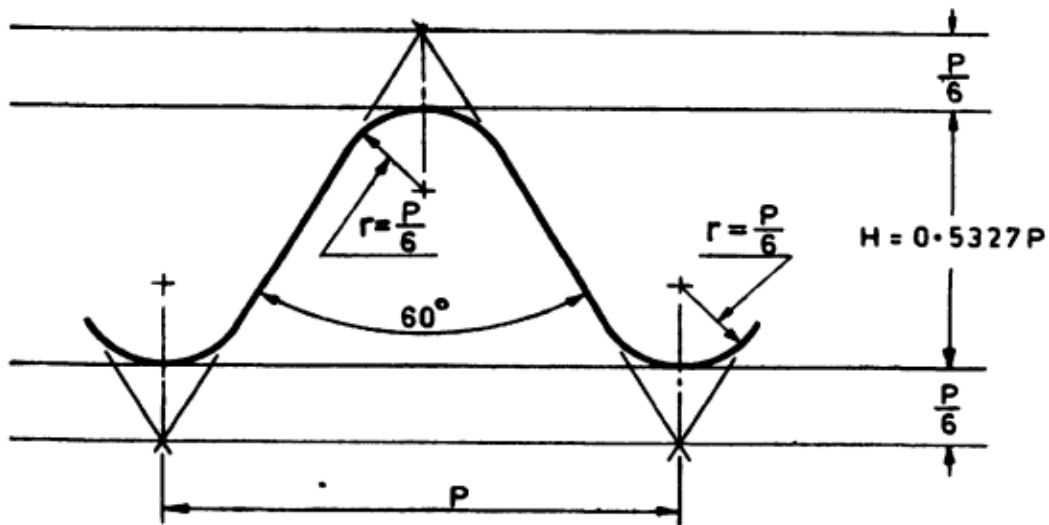

FIG. 2 FORM OF THREAD

Table 1 Dimensions of Form Thread
 (Clause 4.1)

All dimensions in millimetres

Sl No.	Size	Pitch P	External Thread						Internal Thread					
			Major Dia.		Effective Dia.		Minor Dia.		Major Dia.	Effective Dia.		Minor Dia.		
			Max	Min	Max	Min	Max	Min	Min	Max	Min	Max	Min	
(1)	(2)	(3)	(4)	(5)	(6)	(7)	(8)	(9)	(10)	(11)	(12)	(13)	(14)	
i)	7.94 × 0.98	0.977	7.938	7.798	7.417	7.325	6.896	6.706	7.938	7.508	7.417	7.093	6.896	

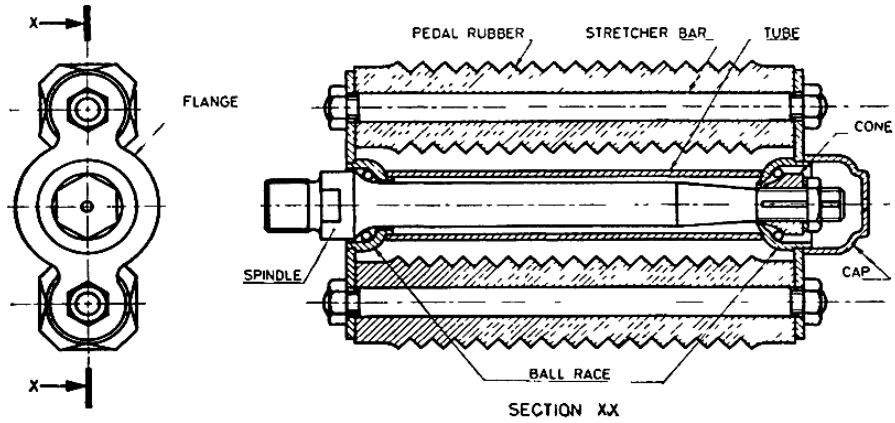
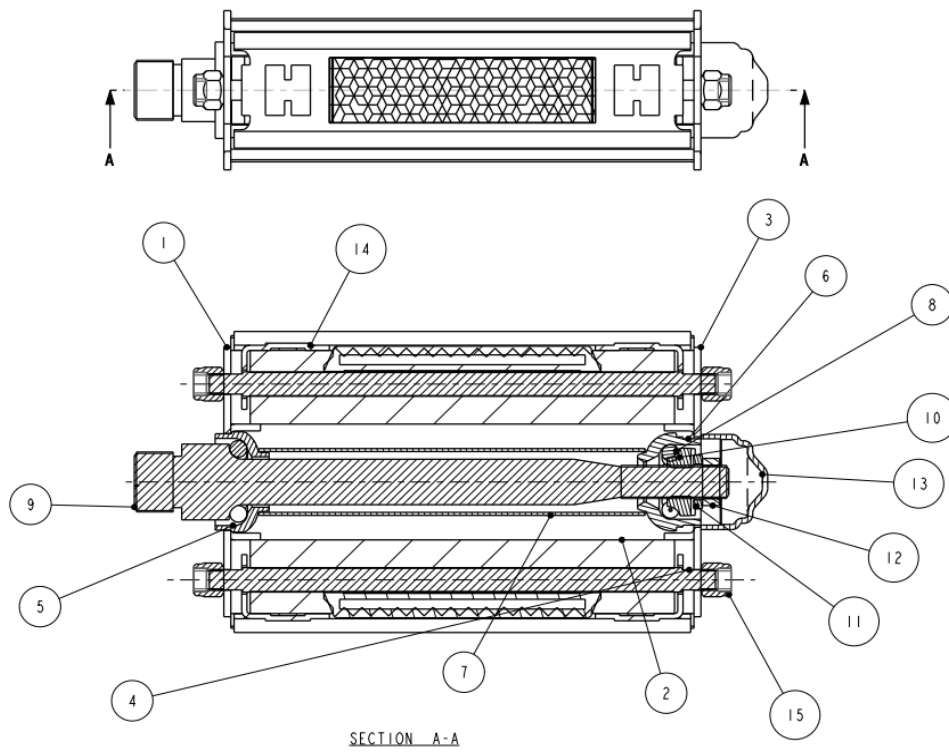
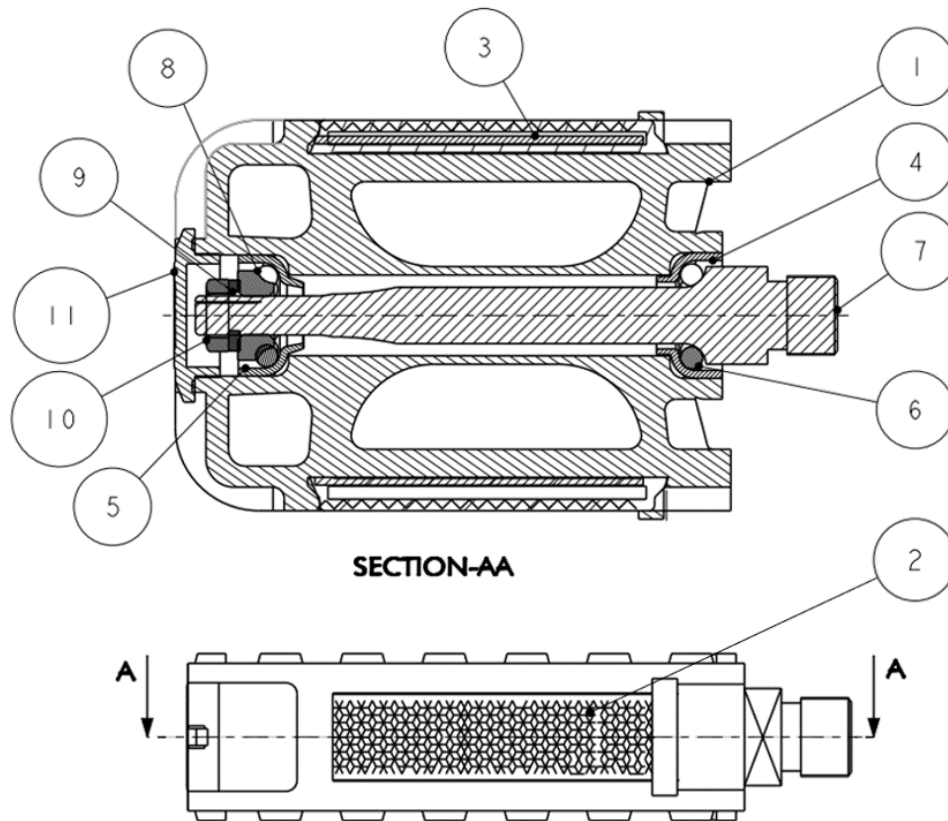

FIG. 3 BLOCK TYPE PEDAL ASSEMBLY (SCHEMATIC)



No.	Name of Parts	No.	Name of Parts
1	Pedal Plate Crank End	9	Pedal Axle
2	Pedal Block	10	Pedal Axle Cone
3	Pedal Plate Cone End	11	Lock Washer
4	Stretcher Bar	12	Pedal Axle Nut
5	Crank End Cup	13	Dust Cover
6	Cone End Cup	14	Block Plate
7	Pedal Pipe	15	HEX NYLOC Nut M5 X 0.8P
8	Steel Ball		

FIG. 4 RAT-TRAP/HEAVY DUTY TYPE PEDAL ASSEMBLY (SCHEMATIC)



No.	Name of Parts	No.	Name of Parts
1	Pedal Body	7	Pedal Axle
2	Pedal Reflector	8	Pedal Axle Cone
3	Reflector Strip	9	Lock Washer
4	Crank End Cup	10	Pedal Axle Nut
5	Cone End Cup	11	Pedal Cap
6	Steel Ball		

FIG. 5 INTEGRAL TYPE PEDAL ASSEMBLY (SCHEMATIC)

5 MANUFACTURE

5.1 Pedal shall be fitted to the spindle for free rotations. The pedal spindle assembly shall be then connected to the crank arm through threads for transferring the motion or power to the chain wheel. The threads shall be so formed as to facilitate easy fitting and replacement. The pedal spindle shall have a right-handed crank fitting thread if it is a right pedal spindle and a left-handed crank fitting thread if it is a left pedal spindle. The pedal shall bear a marking of “Right” or “Left” accordingly. The reflector attached to the pedal body shall conform to IS/ISO 6742-2.

6 FINISH

6.1 The spindles may preferably be chemically coloured or plated.

6.2 The tubes, flanges, stretcher bars and caps, if made of steel shall be finished smooth and shall be enamelled or nickel-chrome plated to Service Grade No. 1 [Classification Code Fe/(s Ni) 10b (Cr r)] of IS 1068 or cadmium plated to Service Condition No. 2 (Classification No. Fe/Cd 8) of IS 1572 or zinc plated to Service condition No. 2 (Classification No. Fe/Zn 7.5) of IS 1573 and if made of aluminium alloys shall be finished smooth and shall be enamelled or nickel-chrome plated to Service Grade No. 1 [Classification Code Al/(s Ni) 10b (Cr r)] of IS 1068.

NOTE

In view of the shape of some of the components a uniform thickness of plating is not to be expected. Therefore, in order to ensure that the thickness of nickel plating at any point is not less than that specified, an appropriately higher plating thickness should be aimed at.

6.3 Finished surfaces without plating shall be given a suitable rustproof treatment unless the substrate material is corrosion resistant.

6.4 Exposed edges that could come into contact with the rider's hands, legs, etc, during normal riding or normal handling and normal maintenance shall not be sharp, for example, deburred, broken, rolled, or processed with comparable techniques.

7 TESTS

All strength tests involving any synthetic resin/plastic materials shall be pre-conditioned for two hours and tested at an ambient temperature of $23\text{ }^{\circ}\text{C} \pm 5\text{ }^{\circ}\text{C}$.

7.1 Static Load Test (Not applicable to Young Children's bicycles)

7.1.1 For 'Young adult bicycles'; 'City and Trekking'; 'Roadster'; 'SLR bicycles'; 'Mountain bicycles'; and 'Racing bicycles', the pedal shall pass the test as specified in **4.10.3** of IS 10613.,

7.1.2 For BMX bicycles, the pedal shall pass the test as specified in **4.14.3** of DOC: TED 16 (18837)

7.1.3 For EPAC bicycles, the pedal shall pass the test as specified in **4.3.12.3** of TED 16 (23339).

7.2 Dynamic Durability Test

7.2.1 For bicycles for young children, the pedal shall pass the test as specified in **4.12.4** of Doc TED 16(23113)

7.2.2 For 'Young adult bicycles'; 'City and Trekking'; 'Roadster'; 'SLR bicycles'; 'Mountain bicycles'; and 'Racing bicycles', the pedal shall pass the test as specified in **4.10.5** of IS 10613.,

7.2.3 For BMX bicycles, the pedal shall pass the test as specified in **4.14.4** of DOC: TED 16 (18837)

7.2.4 For EPAC bicycles, the pedal shall pass the test as specified in **4.3.12.5** of TED 16 (23339).

7.3 Impact Test

7.3.1 Impact Test on pedal

7.3.1.1 For bicycles for young children, the pedal shall pass the test as specified in **4.12.3** of Doc TED 16(23113)

7.3.1.2 For 'Young adult bicycles'; 'City and Trekking'; 'Roadster'; 'SLR bicycles'; 'Mountain bicycles'; and 'Racing bicycles', the pedal shall pass the test as specified in **4.10.4** of IS 10613.,

7.3.1.3 For BMX bicycles, the crank/pedal assembly shall pass the test as specified in **4.14.5.1** of DOC: TED 16 (18837)

7.3.1.4 For EPAC bicycles, the pedal shall pass the test as specified in **4.3.12.4** of TED 16 (23339).

7.3.2 Impact Test on Plastic (Synthetic Resin) Pedal (Only applicable to BMX bicycles)

For BMX bicycles, the plastic pedal shall pass the test as specified in **4.14.5.2** of DOC: TED 16 (18837).

7.3.3 Toxicity Test

7.3.3.1 For bicycles for young children, the pedal shall pass the test as specified in **National Annex A** of Doc TED 16(23113).

7.3.3.2 For ‘Young adult bicycles’; ‘City and Trekking’; ‘Roadster’; ‘SLR bicycles’; ‘Mountain bicycles’; and ‘Racing bicycles’, the pedal shall pass the test as specified in **4.1.2** of IS 10613.

7.3.3.3 For BMX bicycles, the crank/pedal assembly shall pass the test as specified in **4.20** of DOC: TED 16 (18837)

7.3.3.4 For EPAC bicycles, the pedal shall pass the test as specified in **4.3.1.9** of TED 16 (23339).

8 MARKING

8.1 The pedal assembly shall be marked indicating the source of manufacture and/or trademark. The pedal assembly shall carry suitable identification mark for left hand threads as indicated in Fig 1.

8.2 BIS Certification Marking

8.2.1 The pedal assembly may also be marked with the Standard Mark.

8.2.2 The product(s) conforming to the requirements of this standard may be certified as per the conformity assessment schemes under the provisions of the *Bureau of Indian Standards Act, 2016* and the Rules and Regulations framed thereunder, and the products may be marked with the standard mark.