

For Comments Only

BUREAU OF INDIAN STANDARDS

DRAFT FOR COMMENTS ONLY

(Not to be reproduced without the permission of BIS or used as an Indian Standard)

भारतीय मानक मसौदा

साइकिलें — साइकिल रिम्स — विशिष्टि

(आई एस 624 का पांचवां पुनरीक्षण)

Draft Indian Standard

BICYCLES — BICYCLE RIMS — SPECIFICATION

(Fifth Revision of IS 624)

ICS 43.150

Bicycles Sectional Committee, TED 16

**Last date for receipt of comments is
11/06/2024**

FOREWORD

(Formal clause will be added later)

This standard was initially published in 1955 and revised in 1961, 1991 and 2003. In this revision, besides others changes several new profiles of rims have been included. The provision of more number of spoke holes have also been made.

While preparing this standard, considerable assistance has been drawn from the following:

- ISO 5775-2:2021 'Bicycle tyres and rims Part 2: Rims' issued by the International Organization for Standardization; and
- JIS D 9421:2009 'Rims for bicycles' published by Japanese Industrial Association.

The composition of the Committee responsible for the formulation of this standard will be added later.

For the purpose of deciding whether a particular requirement of this Standard has complied with the final value, observed or calculated, expressing the result of a test or analysis shall be rounded off as per IS 2 : 2022 Rules for rounding off numerical values (*Second revision*). The number of significant places retained in the rounded-off value should be the same as that of the specified value in this Standard.

Draft Indian Standard

BICYCLES — BICYCLE RIMS — SPECIFICATION
(*Fifth Revision*)

1 SCOPE

This standard specifies the dimensions and other requirements of bicycle & rickshaw rims made out of steel, aluminium or any other material suitable for tyres of the same sizes conforming to IS 2414.

2 REFERENCES

The following standards contain provisions, which through reference in this text, constitute provisions of the standards. At the time of publication, the editions indicated were valid. All standards are subject to revision and parties to agreements based on this standard are encouraged to investigate the possibility of applying the most recent editions of the standards indicated below:

<i>IS/ISO No.</i>	<i>Title</i>
513 (Part 1): 2016	Cold Reduced Carbon Steel Sheet and Strip Part 1 Cold Forming and Drawing Purposes
1285: 2023	Wrought Aluminium and Aluminium Alloys - Extruded Round Tube and Hollow Sections for General Engineering Purposes (<i>fourth revision</i>)
2414: 2023	Cycle and rickshaw pneumatic tyres — Specification (<i>fourth revision</i>)
1068: 1993	Electroplated coatings of nickel plus chromium and copper plus nickel plus chromium on iron and steel (<i>third revision</i>)
1599: 2023/ ISO 7438: 2020	Method for bend test (<i>fifth revision</i>)
1608 (Part 1): 2022/ ISO 6892-1: 2019	Metallic materials - Tensile testing - Part 1 : Method of test at room temperature (<i>first revision</i>)
10613: 2023	Cycles - Safety and performance requirements for bicycles (<i>third revision</i>)
DOC: TED 16 (23113)	Cycles - Safety requirements for bicycles for young children (<i>Second revision of IS 15533 : 2018/ISO 8098: 2014</i>) (<i>under development</i>)
DOC: TED 16 (18837)	BMX bicycles – Safety requirements and test methods (<i>under development</i>)
DOC: TED 16 (23339)	Cycles — Electrically power-assisted cycles (EPAC): Part 1 Pedal-Assisted Bicycles (<i>under development</i>)

3 CLASSIFICATION

This standard covers the following basic types of the rims:

3.1 Steel Rims:

- a) Beaded edge (BE);
- b) Straight side (SS);
- c) Hooked bead (HB);
- d) Hooked edge (HE); and
- e) Crotchet (C).

3.2 Alloy Rims:

- a) Tubeless Straight side (TSS);
- b) Tubeless Crotchet (TC);
- c) Single wall (SW);
- d) Double wall (DW); and
- e) Triple wall (TW).

4 TERMS AND DEFINITIONS

For the purposes of this standard, the following terms and definitions shall apply.

4.1 Rim base

Tyre side portion of the rim profile which comes into contact with tyre beads during mounting, inflation and use.

4.2 Weather side of the rim

Portion of the rim profile exposed to ambient weather conditions.

4.3 Tyre side of the rim

Portion of the rim profile used for tyre mounting and retention.

5 SHAPES AND DIMENSIONS

5.1 The typical profiles of various types of rims are illustrated in Fig. 1 to Fig 10. These profiles are for guidance only and are intended for the design of the corresponding rolling dies and not intended to be measured on the rim.

5.2 The dimensions of rims shall be as specified in Table 1 to Table 13. Methods for measuring and gauging bicycle rim dimensions is given in Annex A.

5.2.1 Measurement of Circumference

The circumference of the rim is measured along the bead seat by a steel measuring tape conforming to dimensions given in Table 18.

5.3 The tolerance on steel strip thickness, used for making rims shall be as specified in IS 513 (Part 1). The tolerance on extruded aluminium alloy rim profile thickness shall be as specified in IS 1285.

6 MATERIAL

6.1 Rims shall be manufactured from cold-rolled carbon steel strips having the following physical properties when tested in accordance with IS 1608:

Ultimate tensile strength, <i>Min</i>	310 MPa
Yield strength, <i>Min</i>	185 MPa
Elongation, <i>Min</i>	25 percent on 50 mm

6.1.1 The steel strip shall be capable of being flattened on itself without any signs of fracture (*see* IS 1599).

6.2 Aluminium rim shall be manufactured from extruded aluminium alloy having the following physical properties when tested in accordance with IS 1285:

Tensile strength, <i>Min</i>	215 MPa
Yield strength, <i>Min</i>	160 MPa
Elongation, <i>Min</i>	10 percent on 50 mm
Hardness, <i>Min</i>	70 BHN
The Joining pin shall have hardness of 150 ± 10 BHN	

7 DESIGNATION

The rim shall be designated by the type, nominal width code, nominal rim diameter code and material name.

Example — A rim of Type BE with nominal rim diameter 635 mm and width code 25 mm and the material made out of steel shall be designated as BE-635-25-Steel.

Rim made out of aluminium alloy shall be designated as BE-635 -25-AlAlloy and same is applicable for tubeless type rim.

8 MANUFACTURE

8.1 The holes for spokes and valves shall be punched or drilled in accordance with the dimensions given in Fig. 11, Fig. 12 and Table 14 to Table 16 and variation in pitch of spoke hole should be within 2 mm. The valve hole shall be pierced centrally on the nose of rim and shall be at the centre of the two spoke holes. The holes shall be clear, circular, and free from burrs.

8.2 The rims made of steel may be provided with drain holes of 2.5 mm diameter on either side of the bead seat. The holes shall be located diametrically opposite to each other, that is, at least two holes on each bead and in all, not less than four holes to a rim.

8.2.1 The joint line on the tyre side and edge of spoke hole, valve hole shall be free from visible burrs.

8.2.2 The position of valve hole relative to spoke holes shall be as shown in Fig. 11 and Fig. 12 when viewed from the tyre side.

8.2.3 The valve or spoke hole should not be punched on the weld joining line or on the pin joining line of the rim in the case of the aluminium alloy rim.

8.2.4 For aluminium alloy rim the joints shall be made with the help of the pin which has the double shearing load of 1 000 kgf (Min).

8.2.5 The closing force for the joining pin with the rim shall be 1 000 kgf (Min).

8.3 The rims shall be manufactured circular in shape. The difference between any two mutually perpendicular inside diameters shall not exceed 6 mm.

8.4 The flatness of both the faces of the rim shall be within 2 mm when measured by a feeler gauge on a flat surface.

8.5 For tubeless applications with through-drilled spoke holes, the rim base protection must provide an air-tight seal adequate for the maximum allowable pressure as recommended by the rim manufacturer.

8.5.1 Tyres that are labelled with “tubeless” or “tubeless ready” can be used without inner tube. Tyres that are not labelled accordingly shall be used with an inner tube.

9 FINISH

9.1 The rim shall be free from rust, scale and oily substances. It shall be suitably pre-treated and plated or powder-coated or painted.

9.2 The plated rims shall be nickel plus-chrome plated and the electroplated coatings shall conform to service condition No. 1 with classification code Fe/Ni 10b Cr r of IS 1068 with provision that s nickel may be substituted for b nickel, and mc or mp chromium may be substituted for r-chromium.

The plating on the significant surfaces (*see* Fig. 13) shall not be less than the minimum specified for the service condition of IS 1068. The aluminium alloy shall be nickel plus chrome plated and the electroplated coatings shall conform to service condition No. 1 with classification code Al/Ni 10b Cr r with the provision that p, d or s nickel, may be substituted for b nickel and mc or mp chromium may be substituted for r-chromium.

Anodizing thickness for Al-alloy rim shall be 5-10 microns.

NOTE — The significant surface implies the extended surface of the rim after fixing the tyre.

10 COMPRESSION TEST

10.1 Testing Machine

The test shall be conducted on any suitable device, which is capable of loading the rim in the manner schematically indicated in Fig. 14.

10.2 Procedure

The rim shall be held between the two supports keeping the joint at right angle to the line of loading. The load shall be gradually increased to a load of 50 kg for adult bicycles & 30 kg for young children and kept for 2 min. The load shall then be released and the rim shall be examined. The permanent deformation at the point of application of load shall be 1 mm or less.

11 TEST FOR FINISH

11.1 Physical test

A solid steel ball measuring 13 mm in diameter shall be dropped from a height of 1.5 m on any painted, powder-coated or plated significant surface of the rim. The painted, powder-coated or plated portion where the steel ball strikes the frame sample shall withstand the Impact without any sign of tear or peeling off.

11.2 Chemical test

11.2.1 Painted, powder-coated, or plated rim shall be tested according to one of the applicable tests as described in Table 17.

11.2.2 In the case of the painted surface, the paint shall not soften, peel off or show any colour change when tested as per **11.2.1**.

11.2.3 In the case of powder-coating or plating, there shall be no adhesion loss, blisters or flaking on an area more than 3mm on either side from X-cut when tested as per **11.2.1**.

12 MARKING

12.1 The rims shall bear the rim designation, source of manufacture and/or trade-mark.

12.2 BIS Certification Marking

The rims may also be marked with the Standard Mark.

12.2.1 The use of the Standard Mark is governed by the provisions of the Bureau of Indian Standards Act, 1986 and the Rules and Regulations made thereunder. The details of conditions under which the licence for the use of the Standard Mark may be granted to the manufacturers or producers may be obtained from the Bureau of Indian Standards.

13 PACKING

Rims shall be packed in such a way that they are not damaged during transit.

14 SYMBOLS

The following symbols are used in this standard:

- A — Specified rim width,
- A₁ — Rim width at the tyre bead seat,
- D — Specified rim diameter,
- D₁ — Measuring rim diameter,
- D₂ — Outer diameter,
- G — Flange height,
- H, H₁ — Unobstructed minimum depth above rim base with rim tape fitted to permit tyre fitment,
- H₂ — Overall Height of the Rim,
- L₁ — Well width above rim tape,

- P — Bead seat width,
- R₂ — Flange radius,
- R₃ — Bead seat radius,
- R₄ — Well top radius,
- W — Measuring tape width, and
- B — Bead seat angle.

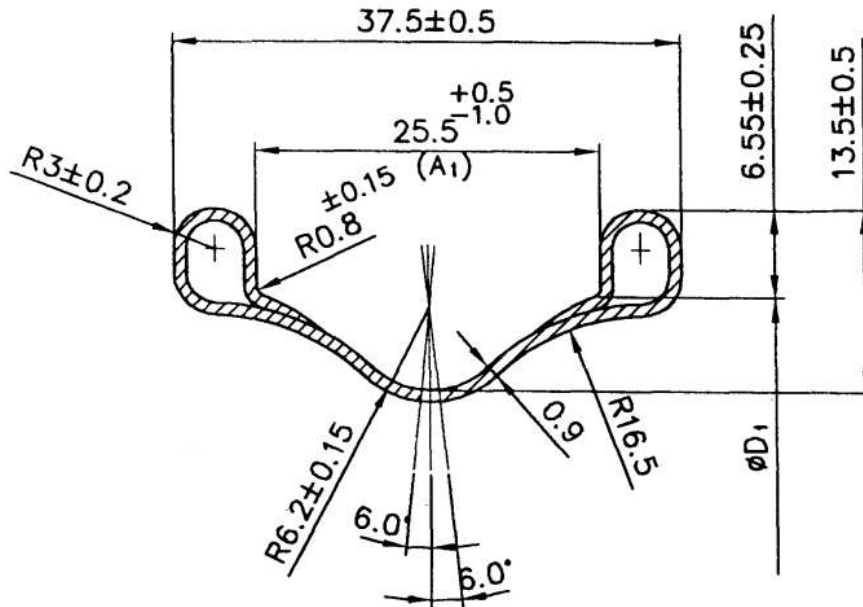

All dimensions in millimetres.

FIG. 1 BEADED EDGE CROSS-SECTION DETAILS

Table 1 Dimensions for Beaded Edge Rims
 (Clause 5.2)

All Dimensions in millimetres.

(1)	Type	Nominal Diameter Code	Nominal Width Code	Rim Width at Tyre Bead Seat A_1	Specified Rim Diameter D	Measuring Rim Diameter D_1	Circumference at Bead Seat $D_1 \pm 1.5$	Number of Spoke Hole (Informative Reference)
(1)	(2)	(3)	(4)	(5)	(6)	(7)	(8)	(9)
i)	BE	305	25	25.5	304.70	304.35	956	20
ii)		349	25	25.5	349.20	349.20	1096	
iii)		400	25	25.5	400.10	399.85	1256	20 (or) 28
iv)		408	25	25.5	408.75	408.40	1293	
v)		534	25	25.5	535.50	533.15	1676	32 (or) 36 (or) 40 (or) 64
vi)		540	25	25.5	539.60	539.25	1695	
vii)		559	25	25.5	558.60	558.45	1755	
viii)		584	25	25.5	583.90	583.55	1834	
ix)		635	25	25.5	634.70	694.35	1994	

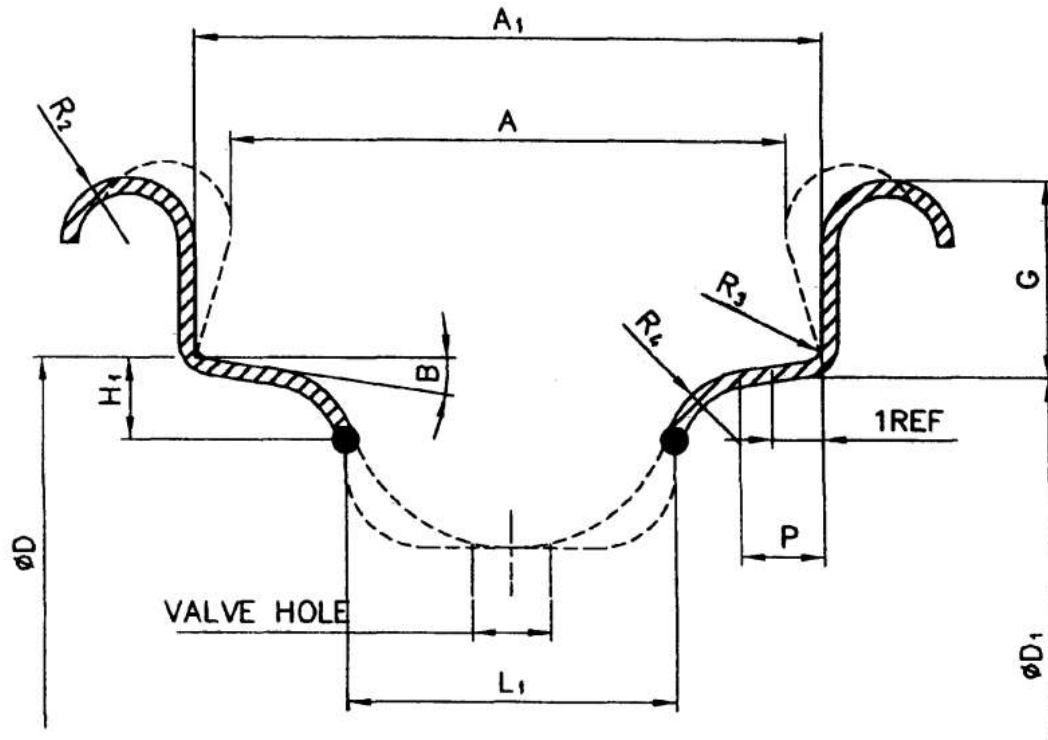

FIG. 1 STRAIGHT SIDE RIMS

Table 2 Dimensions of Straight Side Rims
 (Clause 5.2)

All Dimensions in millimetres.

Sl No.	Type	Nominal Rim Width Code	A ± 1	A ₁ +0 -1	G ± 0.5	P Min.	H ₁ ¹⁾²⁾ Min.	L ₁ ²⁾ Min.	R ₂ Min.	R ₃ Min.	R ₄ Min.	B ³⁾ +5° -0°
(1)	(2)	(3)	(4)	(5)	(6)	(7)	(8)	(9)	(10)	(11)	(12)	(13)
i)	SS	18.0	18.0	18.0	6.6	1.8	1.8	10	1.5	1.0	1.5	10°
ii)		20.0	20.0	-	6.5	2.0	2.0	11	1.8	1.0	1.5	10°
iii)		20.0	20.0	20.3	6.5	2.0	2.2	11	1.2	0.8	2.4	10°
iv)		22.0	22.0	-	6.5	2.2	3.0	11	1.8	1.0	2.0	10°
v)		24.0	24.0	-	7.0	3.0	3.0	11	2.0	1.0	2.5	10°
vi)		27.0	27.0	-	7.5	3.5	3.5	14	2.5	1.0	2.5	10°
vii)		30.5	30.5	-	8.0	3.5	3.5	14	2.5	1.0	2.5	10°

¹⁾ For r 400 mm diameter and smaller, increase depth H₁ by 1 mm.

²⁾ The dimension H₁ in conjunction with dimension L₁ defines the unobstructed space above the rim base and the nipple heads. With the rim tape fitted, to permit satisfactory tyre fitment. The actual well depth of the rim shall be defined at the discretion of rim manufacturers to achieve this objective.

³⁾ For rolled rims with nominal rim diameter of 400 mm and smaller, B = 15° ± 10°.

Table 3 Specified and Measuring Rim Diameters for Straight Side Rims
 (Clause 5.2)

All Dimensions in millimetres.

Sl No.	Type	Nominal Rim Diameter Code	Specified Rim Diameter, D	Measuring Rim Diameter ¹⁾ , D ₁
(1)	(2)	(3)	(4)	(5)

i)		194	194.2	193.85
ii)		203	203.2	202.85
iii)		222	222.2	221.85
iv)		239	239.4	239.05
v)		248	247.6	247.25
vi)		251	250.8	250.45
vii)		279	279.2	278.85
viii)		288	287.8	287.45
ix)		298	298.4	298.05
x)		305	304.7	304.35
xi)		317	317.0	316.65
xii)		330	329.8	329.45
xiii)		337	336.6	336.25
xiv)		340	339.6	339.25
xv)		349	349.2	348.85
xvi)		355	355.0	354.65
xvii)		357	357.1	356.75
xviii)		369	368.6	368.25
xix)		381	380.9	380.55
xx)		387	387.1	380.55
xxi)		390	389.6	386.75
xxii)		400	400.1	399.75
xxiii)		406	405.6	405.25
xxiv)		419	418.6	418.25
xxv)		428	428.1	427.75
xxvi)		432	431.6	431.25
xxvii)		438	437.7	437.35
xxviii)		440	439.9	439.55
xxix)		451	450.8	450.45
xxx)		484	484.0	483.65
xxxi)		489	488.6	488.25
xxxii)		490	490.2	489.85
xxxiii)	SS	498	497.5	497.15
xxxiv)		501	501.3	500.95
xxxv)		507	507.3	506.95
xxxvi)		520	520.2	519.85
xxxvii)		531	530.6	530.25
xxxviii)		534	533.5	533.15
xxxix)		540	539.6	539.25
xl)		541	540.8	540.45
xli)		547	546.5	546.15
xlii)		559	558.8	558.45
xliii)		565	564.9	564.55
xliv)		571	571.0	570.65
xlv)		584	583.9	583.55
xlvi)		590	590.2	589.85
xlvii)		597	597.2	596.85
xlviii)		609	609.2	608.85
xlix)		622	622.3	621.95
l)		630	629.7	629.35
li)		635	634.7	634.35
lii)		642	641.7	641.35

¹⁾ The tolerance on the measured seat circumference is ($\pi \times$ measuring rim diameter) ± 1.5 mm.

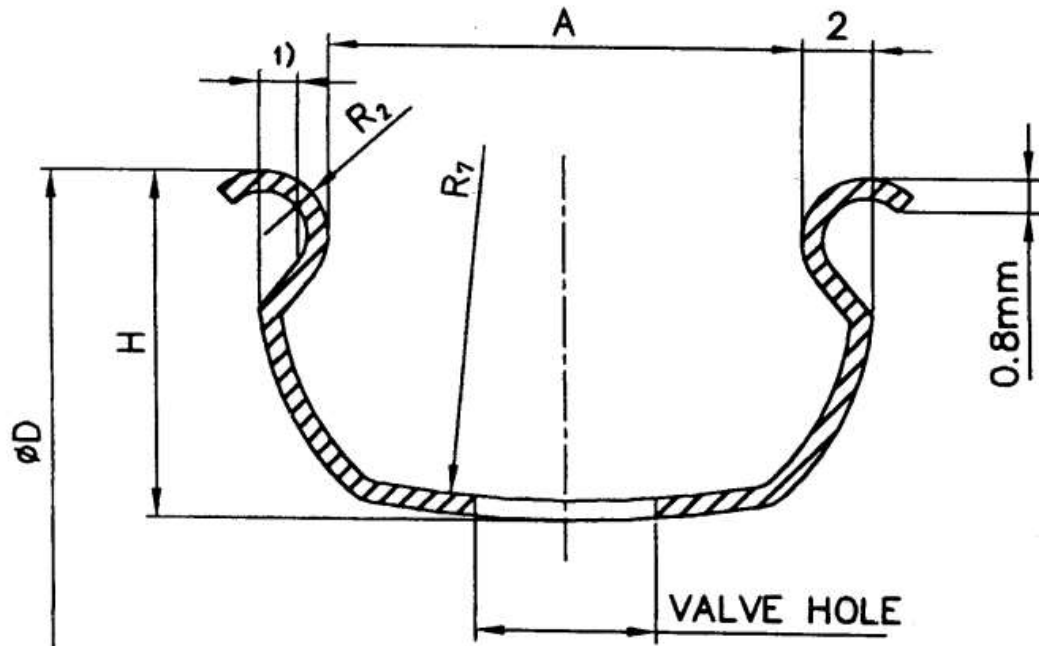

¹⁾ Optional opening not to exceed 1 mm.

FIG. 3 HOOKED BEAD RIMS

Table 4 Dimensions of Hooked Bead Rims
 (Clause 5.2)

All Dimensions in millimetres.

SI No.	Type	Nominal Rim Width Code	A ± 1	H Min.	R_2 ± 0.5	R_7 Min.
(1)	(2)	(3)	(4)	(5)	(6)	(7)
i)	HB	20	20	13	2	30
ii)		25	25	14	2	50
iii)		27	27	15	2	70

Table 5 Specified Rim Diameters and Circumferences for Hooked Bead Rims
 (Clause 5.2)

All Dimensions in millimetres.

SI No.	Type	Nominal Rim Diameter Code	Specified Rim Diameter, D	Specified Rim Circumference $\pi D \pm 2.5$
(1)	(2)	(3)	(4)	(5)
i)	HB	270	269.9	847.9
ii)		321	320.7	1007.5
iii)		372	371.5	1167.1
iv)		422	422.3	1326.7
v)		459	458.8	1441.4
vi)		473	473.1	1486.3
vii)		510	509.6	1601.0
viii)		524	523.9	1645.9
ix)		560	560.4	1760.6
x)		575	574.7	1805.5
xi)		611	611.2	1920.1

All dimensions in millimetre

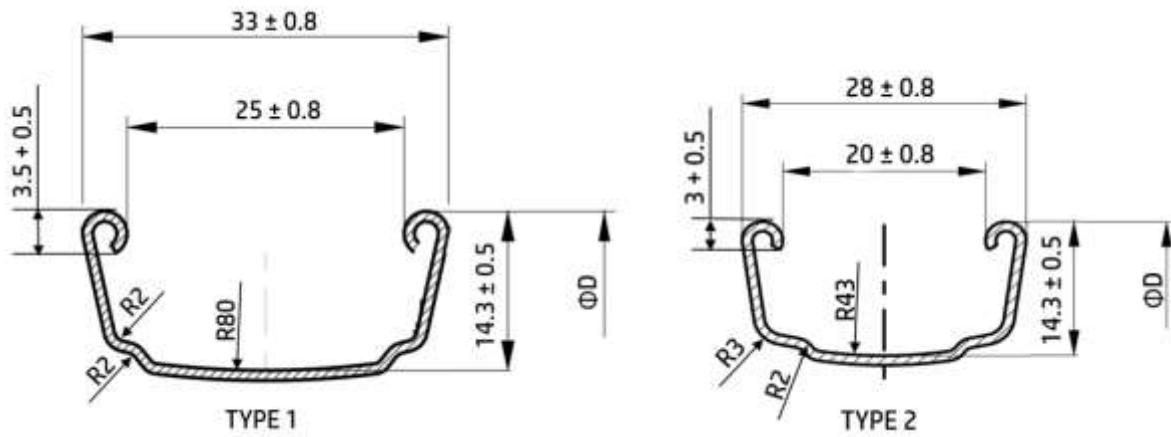

FIG. 4 HOOKED EDGE RIMS

Table 6 Outer Rim Diameters and Circumferences for Hooked Edge Rims
 (Clause 5.2)

All Dimensions in millimetres.

SI No.	Type	Outer Rim Diameter, D	Outer Rim Circumference $\pi D \pm 2.5$	Number of Spoke Hole (Informative Reference)
(1)	(2)	(3)	(4)	(5)
i)	Type 1 (HE1)	217	682	20
ii)		220	691	
iii)		270	848	
iv)		321	1007	20 or 28
v)		371	1167	28 or 36
vi)		422	1327	
vii)		473	1486	
viii)		524	1646	
ix)		575	1805	36
x)	Type 2 (HE2)	270	848	16 or 20
xi)		301	946	20
xii)		321	1007	20 or 28 or 36
xiii)		371	1167	
xiv)		422	1327	
xv)		473	1486	

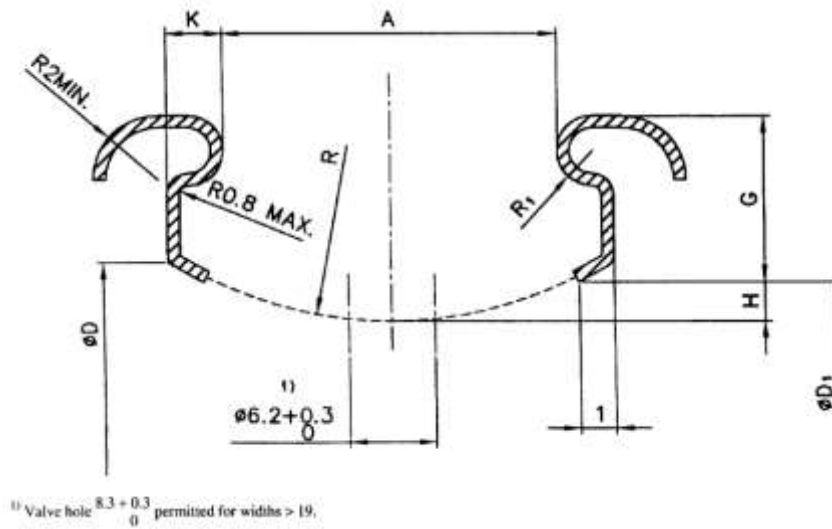

FIG. 5 CROCHET RIMS

Table 7 Dimensions of Crotchet Type Rims
 (Clause 5.2)

All Dimensions in millimetres.

SI No.	Type	Nominal Rim Width Code	A ±0.5	K ±0.5	G ±0.5	H Min. ¹⁾	R ₁ ¹⁾
(1)	(2)	(3)	(4)	(5)	(6)	(7)	(8)
i)	C	13	13	1.5	5.0	2.0	0.9 ± 0.1
ii)		15	15	1.5	5.0	2.0	0.9 ± 0.1
iii)		16	16	1.5	5.5	2.0	1.1 $\begin{smallmatrix} +0.2 \\ -0.1 \end{smallmatrix}$
iv)		17	17	1.5	5.5	2.2	1.1 $\begin{smallmatrix} +0.2 \\ -0.1 \end{smallmatrix}$
v)		19	19	1.5	6.5	2.5	1.1 $\begin{smallmatrix} +0.2 \\ -0.1 \end{smallmatrix}$
vi)	C	21	21	1.5	6.5	2.5	1.1 $\begin{smallmatrix} +0.2 \\ -0.1 \end{smallmatrix}$
vii)		23	23	1.5	7.5	4.5	1.1 $\begin{smallmatrix} +0.2 \\ -0.1 \end{smallmatrix}$
viii)		25	25	1.5	7.5	4.5	1.1 $\begin{smallmatrix} +0.2 \\ -0.1 \end{smallmatrix}$

NOTE

The specified rim diameter (D) and Measuring rim diameter (DI) are same as straight side rims (see Table 4 for details).

¹⁾ Dimensions H and R define the minimum unobstructed space above the rim base and nipple heads to permit satisfactory tyre fitment on a crotchet type rim.

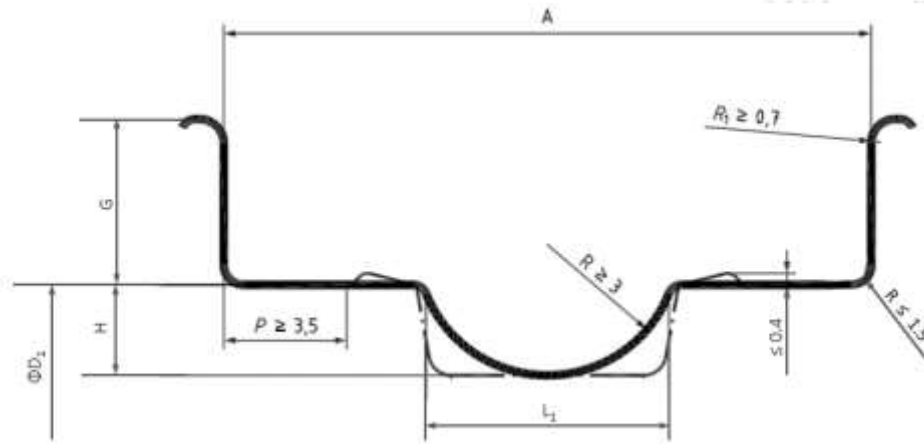

FIG. 6 TUBELESS STRAIGHT-SIDE RIMS

Table 8 Dimensions of tubeless Straight- Side type Rims
 (Clause 5.2)

All Dimensions in millimetres.

Sl No.	Type	Nominal Rim Width Code	A ±0.5	G ±0.5	H		L ₁ Min.
					Max.	Min.	
(1)	(2)	(3)	(4)	(5)	(6)	(7)	(8)
i)	TSS	19	19	6	2.9	3.5	7
ii)		20	20	6	2.9	3.5	7
iii)				6	2.9	3.5	7
iv)		100	100	6	2.9	3.5	7

It is recommended that the ratio G/H < 1.9.

Table 9 Measuring Rim Diameters for Tubeless Straight-Side Rims and Tubeless Crotchet Rims
 (Clause 5.2)

All Dimensions in millimetres.

Sl No.	Type	Nominal Rim Diameter Code	Measuring Rim Diameter, D ₁ ± 0.5
(1)	(1)	(2)	(3)
i)	TSS/TC	559	559
ii)		584	584.1
iii)		622	621.95

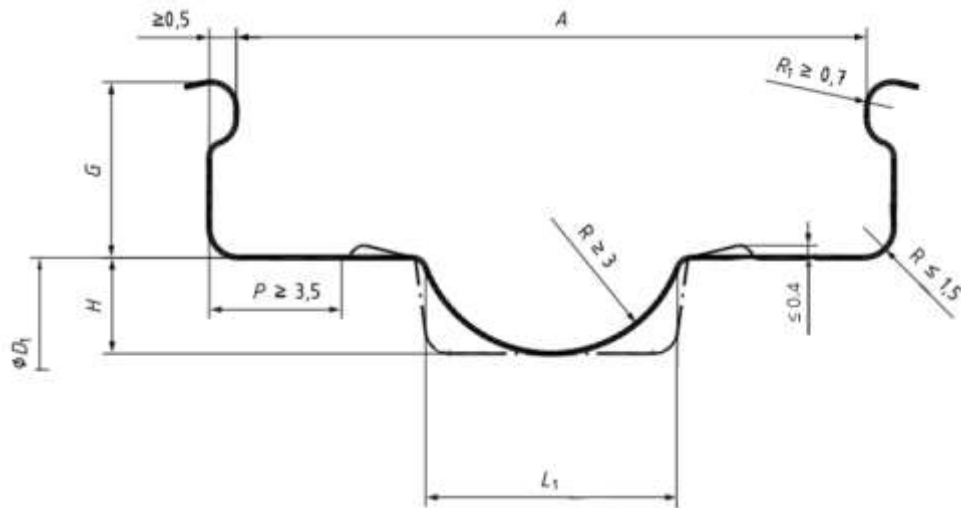

FIG. 7 TUBELESS CROCHET RIMS

Table 10 Dimensions of tubeless Crotchet type rims
 (Clause 5.2)

All Dimensions in millimetres.

SI No.	Type	Nominal Rim Width Code	A ± 0.5	G ± 0.5	H		L ₁ Min.
					Max.	Min.	
(1)	(2)	(3)	(4)	(5)	(6)	(7)	(8)
i)	TC	17	17	5.5	2.6	3.4	7
ii)		18	18	5.5	2.6	3.4	7
iii)				5.5	2.6	3.4	7
iv)		100	100	5.5	2.6	3.4	7

It is recommended that the ratio $G/H < 1.9$.

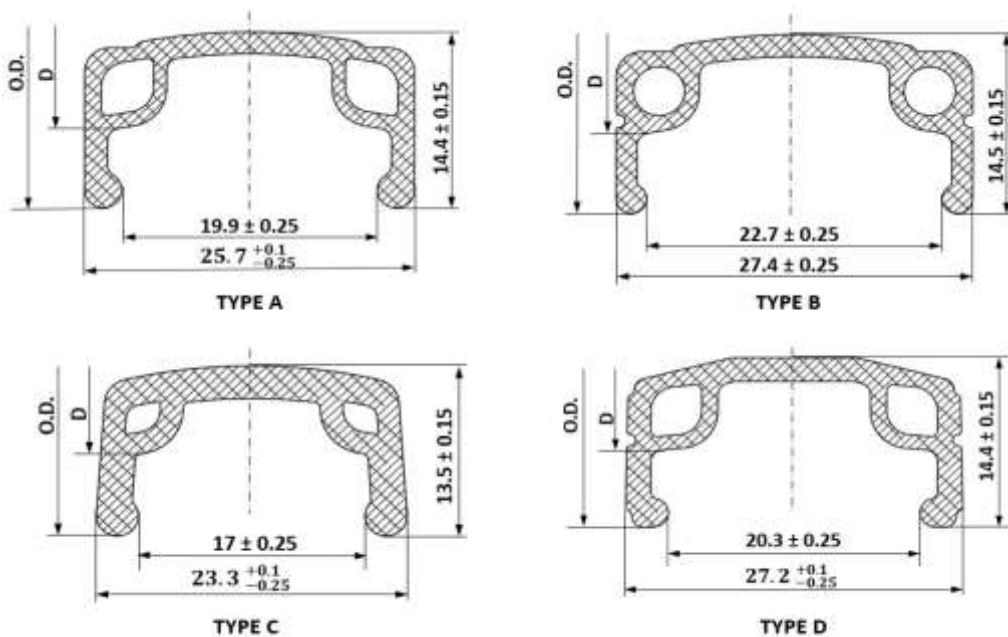

FIG. 8 SINGLE WALL ALLOY RIMS

Table 11 Dimensions of Single Wall Alloy Rims
 (Clause 5.2)

All Dimensions in millimetres.

Sl No.	Type	Section Type	Specified Rim Diameter, <i>D</i>	Outer Rim Diameter, <i>O.D.</i>	Outer Rim Circumference	Number of Spoke Hole (Informative Reference)
(1)	(2)	(3)	(4)	(5)	(6)	(7)
i)	SW	A & B	201.9	214.0	672 ± 2	16
ii)			203.3	216.3	680 ± 2	
iii)			254.0	267.0	839 ± 2	
iv)			302.9	315.0	989 ± 2	
v)		304.7	317.7	998 ± 2	20	
vi)		353.9	366.0	1149 ± 2		
vii)		355.0	368.0	1156 ± 2		
viii)		405.9	418.0	1312 ± 2		
ix)		A, B & D	407.2	420.2	1320 ± 2	20 or 28 or 36
x)			507.9	520.5	1634.5 ± 1.5	
xi)			509.5	522.5	1641.5 ± 1.5	
xii)			560.0	573.0	1801.5 ± 1.5	
xiii)		A	558.4	571.0	1793.0 ± 1.5	36
xiv)			590.8	603.8	1897.0 ± 1.5	
xv)			620.4	633	1987.6 ± 1.5	
xvi)		A & B	622.3	635.3	1995.5 ± 1.5	32 or 36 or 40
xvii)		A	629.2	642.2	2020.2 ± 1.5	
xviii)		C	628.0	641.0	2014.2 ± 1.5	36

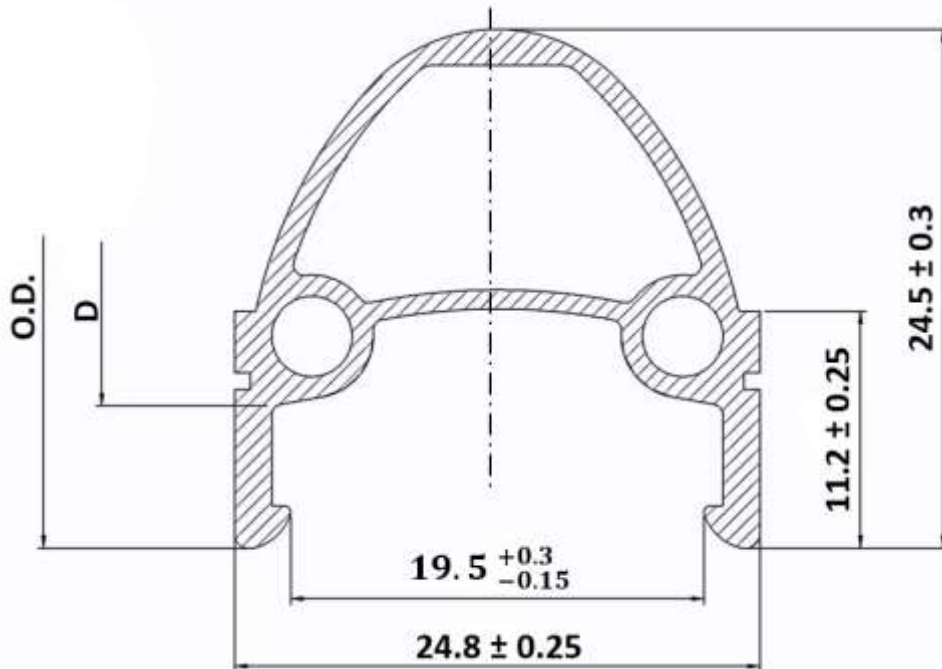

FIG. 9 DOUBLE WALL ALLOY RIM

Table 12 Dimensions of Double Wall Alloy Rims
 (Clause 5.2)

All Dimensions in millimetres

Sl No.	Type	Specified Rim Diameter, D	Outer Rim Diameter, O.D.	Outer Rim Circumference	Number of Spoke Hole (Informative Reference)
(1)	(2)	(3)	(4)	(5)	(6)
i)	DW	404.7	418.0	1312.5 ± 2.0	28 or 36
ii)		407.2	420.2	1320.0 ± 2.0	
iii)		506.7	520.0	1632.8 ± 2.0	
iv)		509.5	522.5	1641.5 ± 1.5	36
v)		560.0	573.0	1880.5 ± 1.5	
vi)		583.7	597.0	1874.6 ± 1.5	
vii)		584.0	597.0	1874.0 ± 1.0	
viii)		619.7	633.0	1987.6 ± 1.5	
ix)		622.3	635.5	1995.5 ± 1.5	

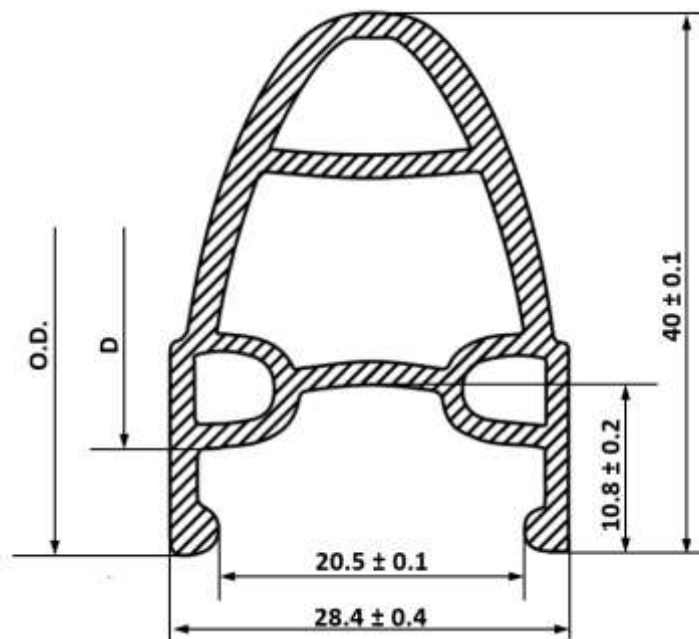

FIG. 10 TRIPLE WALL ALLOY RIM

Table 13 Dimensions of Triple Wall Alloy Rims
 (Clause 5.2)

All Dimensions in millimetres

Sl No.	Type	Specified Rim Diameter, D	Outer Rim Diameter, O.D.	Outer Rim Circumference	Number of Spoke Hole (Informative Reference)
(1)	(2)	(3)	(4)	(5)	(6)
i)	TW	559.1	571.5 ± 0.5	1796.65 ± 2.0	36

Table 14 Spoke Hole Detail
 (Clause 8.1)

All Dimensions in millimetres

Sl No.	Spoke Wire	Hole $\phi M_0^{+0.2}$	Hole $\phi M_B^{+0.1}$
(1)	(2)	(3)	(4)

i)	12G	5.0	8.5
ii)	13G	4.7	
iii)	14G	4.4	

Table 15 Valve Hole Details
 (Clause 8.1)

All Dimensions in millimetres

SI No. (1)	Valve Type (2)	Diameter of Valve Hole, $P_1 \pm 0.1$ (3)
i)	Dunlop valve	8.2
ii)	Auto valve	8.7
iii)	French valve	6.3

Table 16 Position of Spoke Holes
 (Clause 8.1)

All Dimensions in millimetres

SI No. (1)	Classification of Rims (2)	N (3)
i)	Beaded edge rim	$1^{0}_{-0.2}$
ii)	Straight side rim	0.9 ± 0.1
iii)	Tubeless straight side rim	
iv)	Hooked bead rim	2.5 ± 0.1
v)	Hooked edge rim	
vi)	Crotchet rim	$1^{0}_{-0.2}$
vii)	Tubeless crotchet rim	
viii)	Single wall alloy rim	0.8 ± 0.1
ix)	Double wall alloy rim	
x)	Triple wall alloy rim	

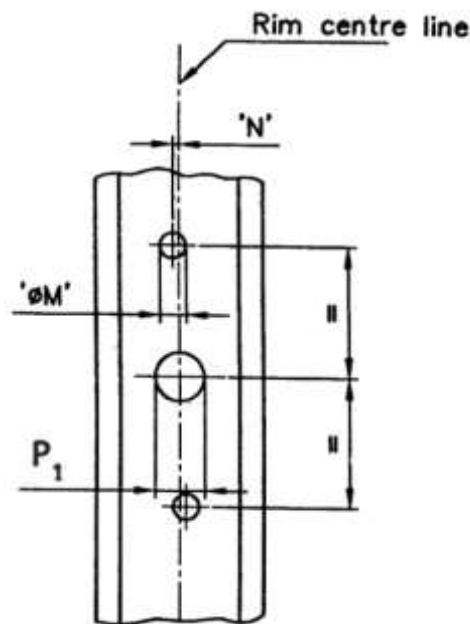

FIG. 11 HOLES FOR SPOKES AND VALVES EXCEPT DOUBLE WALL & TRIPLE WALL ALLOY RIMS

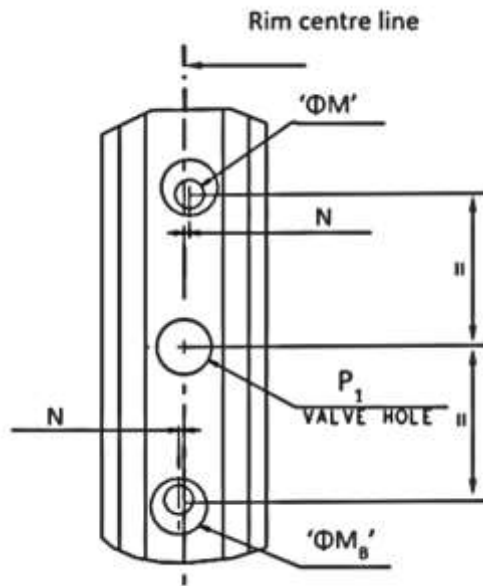

FIG. 12 HOLES FOR SPOKES AND VALVES FOR DOUBLE WALL & TRIPLE WALL ALLOY RIMS

Note: For Triple wall alloy rims ΦM is replaced by $\Phi M \times 2$



FIG. 13 SECTION OF RIM SHOWING SIGNIFICANT SURFACE OF ELECTROPLATING

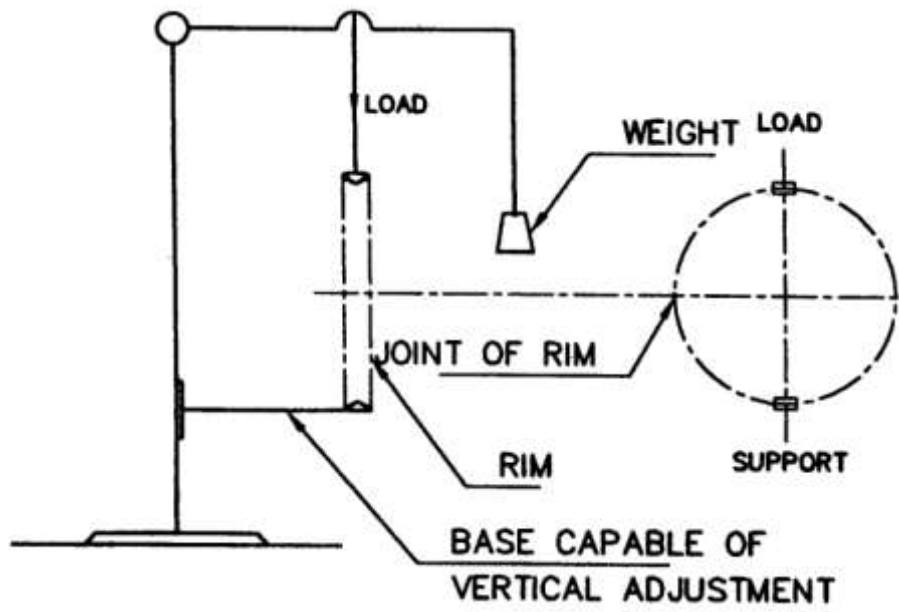

FIG. 14 SCHEMATIC DIAGRAM OF TESTING MACHINE

Table 17 Chemical Tests
(Clause 11.2)

Sl No.	Test/Test conditions/Suitability	Dip Coating Teat	Salt Spray Test	
			Neutral Salt Spray (NSS)	Copper-accelerated Acetic acid Salt Spray (CASS)
(1)	(2)	(3)	(4)	(5)
i)	Temperature	Black enamel paint 80°C	35 °C ± 2 °C	50 °C ± 2 °C
ii)		other enamel paints 60°C		
iii)	Concentration of Salt Solution	5% NaCl	5% NaCl	5% NaCl
iv)	pH (Solution)	6.5 to 7.2	6.5 to 7.2	3.1 to 3.3
v)	Test duration	1 h	2 ¹⁾ h	6 ¹⁾ h
vi)	Recovery period	Nil	1 h	1 h
vii)	Air Pressure	Atmospheric Pressure	70 to 170 kPa	70 to 170 kPa
viii)	Suitability ²⁾	Painted, Coating with metals and their alloys, Metallic coatings (Anodic & Cathodic)	Coating with metals and their alloys, Metallic coatings (Anodic & Cathodic), Conversion coatings Anodic oxide coatings.	Copper + Nickel + Chromium coatings, Nickel + Chromium coatings, Anode coating on Aluminium.

Note 1 Subject to agreement between customer and manufacturer, the duration of salt spray test both for NSS and CASS can be 2, 6, 24, 48, 96, 168, 240, 480, 720 or 1000 h. Wherever there is no such agreement, the duration of the test indicated in Table 18 shall apply.

Note 2 In case of suitability of more than one test, only one test as per manufacturer and supplier agreement shall be done.

ANNEX A

(Clause 5.2 and 5.2.1)

METHODS FOR MEASURING AND GAUGING BICYCLE RIM DIMENSIONS

A-1 PURPOSE

This Annex gives methods for measuring and gauging dimensions of rims.

A-2 GENERAL

All measurements shall be made on rims ready for tyre mounting and placed on flat surfaces. For accurate measurements, gauges and tapes shall always be set perpendicular to the rim flanges on both bead seats.

A-3 MAIN RIM DIMENSIONS TO BE MEASURED AND GAUGED

The main rim dimensions, which shall be measured and gauged, are indicated in Fig. 15 to Fig. 24.

A-4 METHODS OF MEASURING SPECIFIED DIAMETER AND BEAD SEAT CIRCUMFERENCE

The first method (*see* A-4.1) is applicable for straight side rims and beaded edge rims. The second method (*see* A-4.2) is applicable for straight side and crotchet type rims. For single wall alloy rims, double wall alloy rims and triple wall alloy rims both the methods are applicable.

A-4.1 First Method

The rim measurement is made around a standard level circumference related to the mandrel circumference. A tape as illustrated in Fig. 25 may be used, care being taken to choose an appropriate tape for the rim to be measured. The tape shall be made of spring steel and contact the rim on both bead seats equally, it shall be flat, and marked with details of the rim width code and nominal rim diameter. The tape shall also be checked on an appropriate mandrel and on a flat surface, the straight end of the tape shall contact the other end within the notch (*see* Table 18 and Fig. 25 to Fig. 27).

A-4.2 Second Method

The circumference of the upper part of both flanges is measured by means of an inextensible steel tape-line (10 mm width and 0.3 mm thickness, with 0.5 mm graduations), care being taken that it contacts the rim. The two outer circumference measurements U_{0a} and U_{0b} are recorded. Using an appropriate vernier gauge (*see* Fig. 28 and Fig. 30), measure the height of both flanges at least at four points equally spaced around the circumference taking care that the correct protrusion (1 mm for cycle rims) used. Calculate the average of the height for the two flanges, G_a and G_b .

Calculate the measured circumference, U_{1a} and U_{1b} , using the equations:

$$\begin{aligned}U_{1a} &= U_{0a} - 2\pi G_a \\U_{1b} &= U_{0b} - 2\pi G_b\end{aligned}$$

Compare both circumferences with the product of D_1 values (*see* Table 3) by π .

NOTE — When rims have a difference of more than 2 mm between the two outer circumferences U_{0a} and U_{0b} , the gauge should be appropriately applied and a spacer with a thickness δ , catering for the difference in circumference, inserted (*see* Fig. 29):

$$\delta = \frac{U_{0a} - U_{0b}}{2\pi}$$

The spacer should be interposed between the top of the shorter flange and the vernier gauge (*see* Fig. 29).

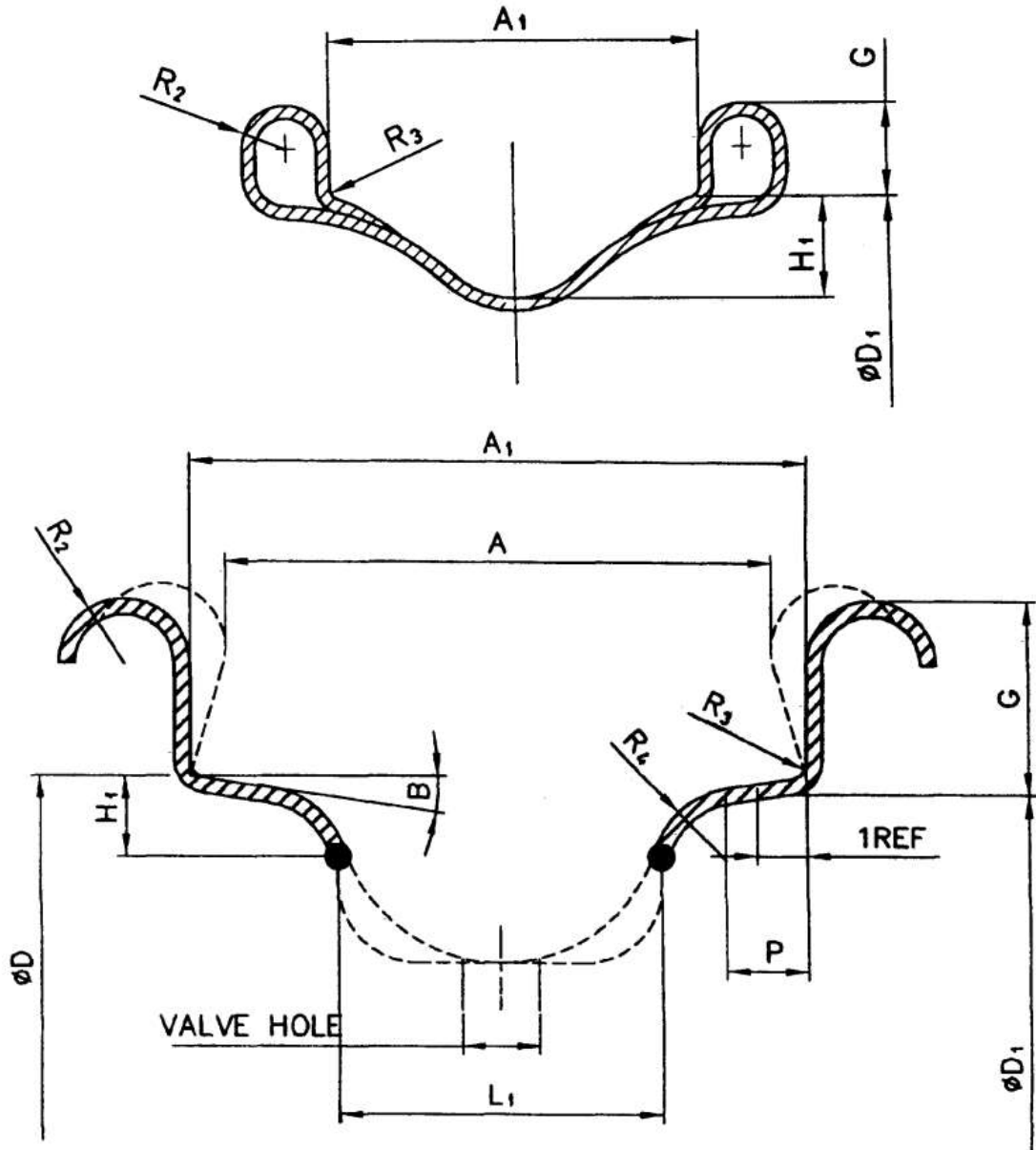

FIG. 16 STRAIGHT SIDE RIMS

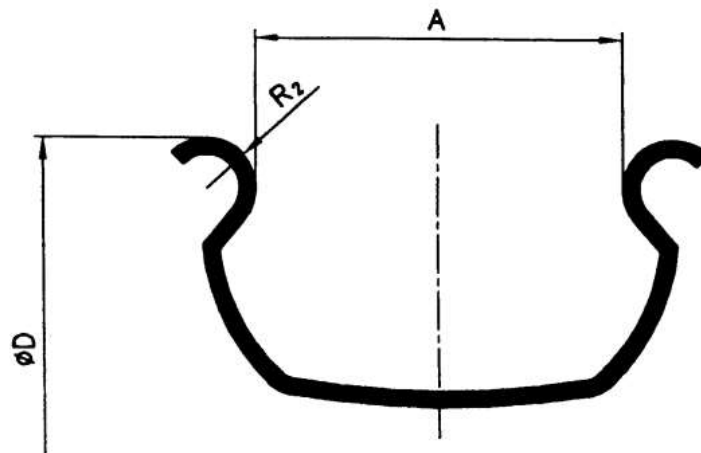

FIG. 17 HOOKED BEAD RIMS

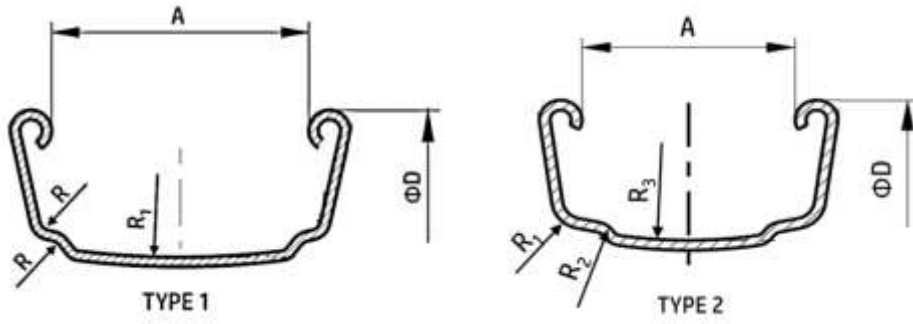

FIG. 18 HOOKED EDGE RIMS

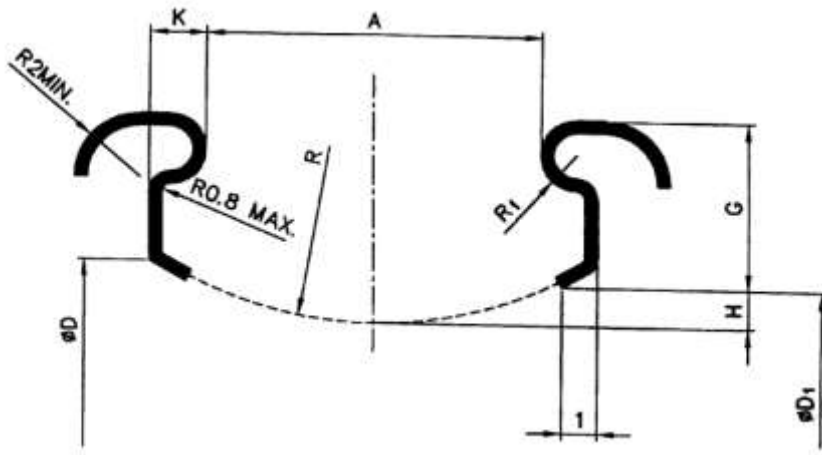

FIG. 19 CROTCHET TYPE RIMS

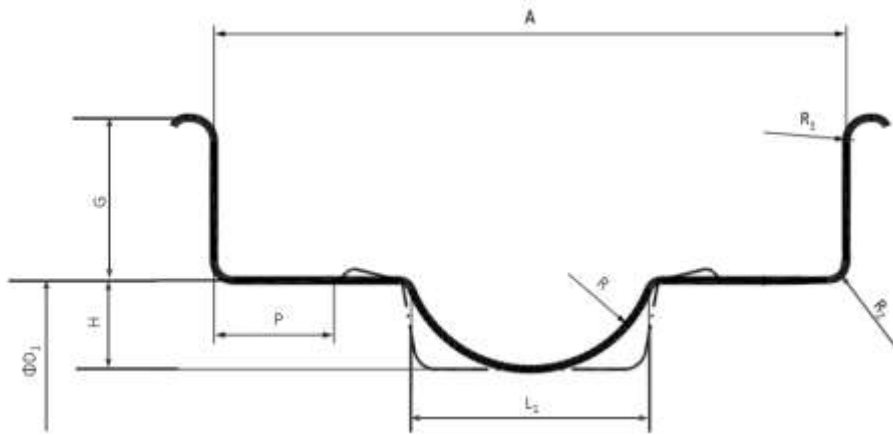

FIG. 20 TUBELESS STRAIGHT SIDE RIMS

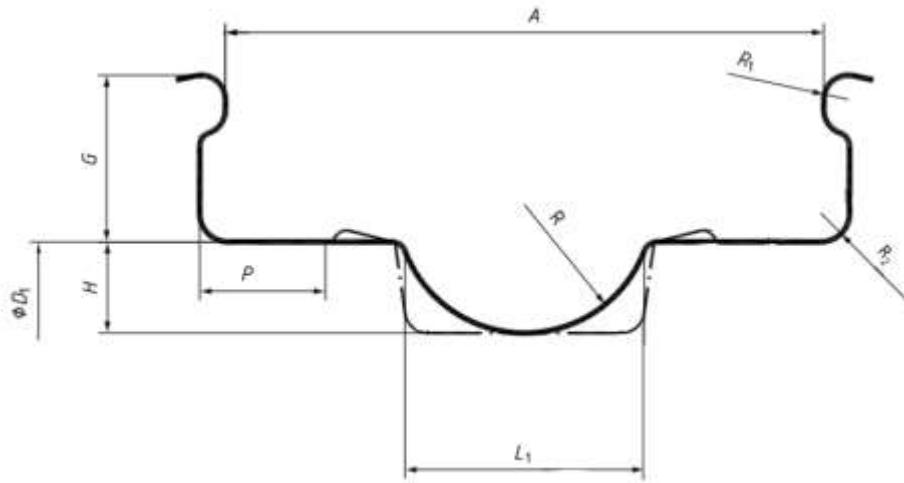

FIG. 21 TUBELESS CROCHET TYPE RIMS

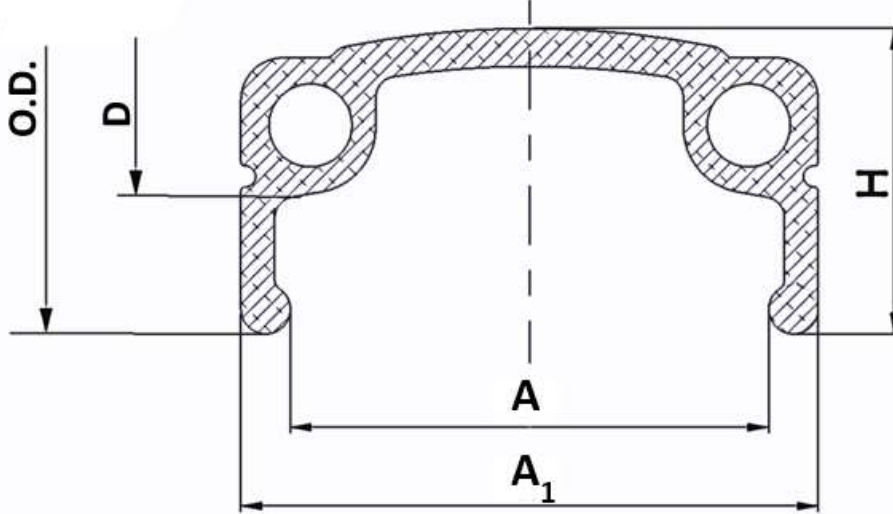

FIG. 22 SINGLE WALL ALLOY RIMS

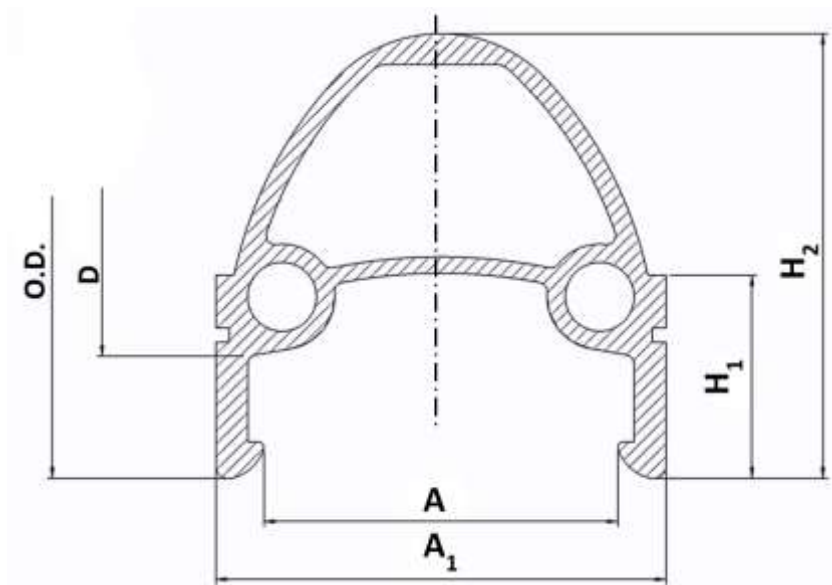

FIG. 23 DOUBLE WALL ALLOY RIMS

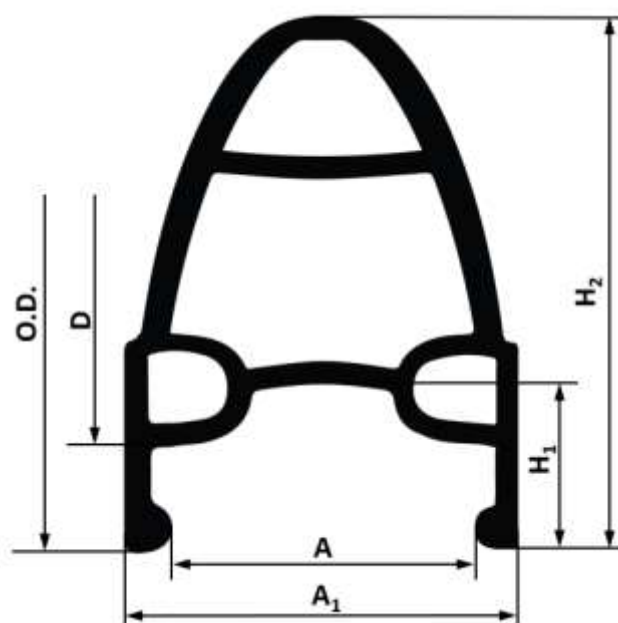

FIG. 24 TRIPLE WALL ALLOY RIMS

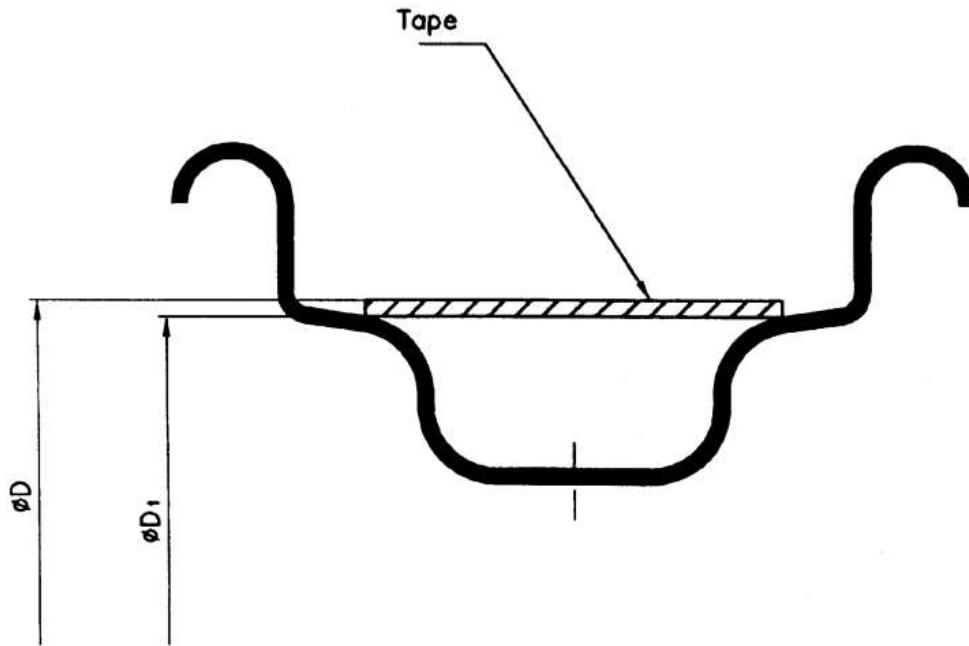

FIG. 25 RIM DIAMETER MEASUREMENT

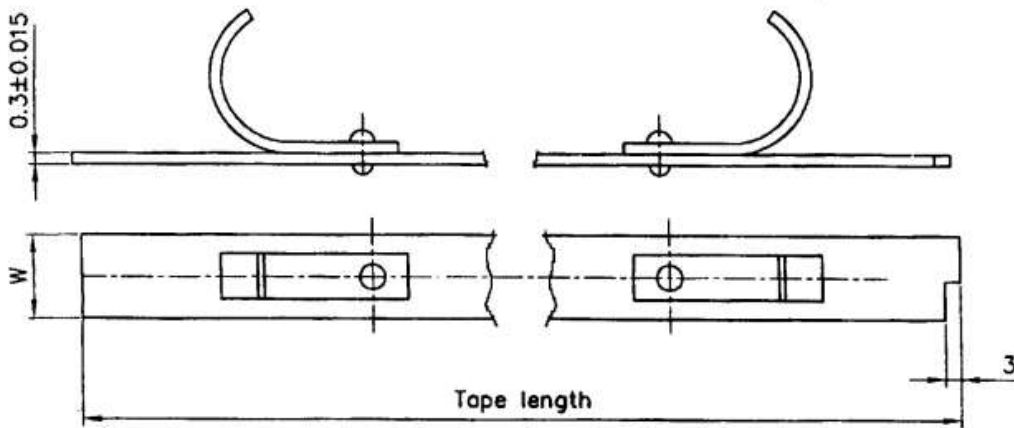
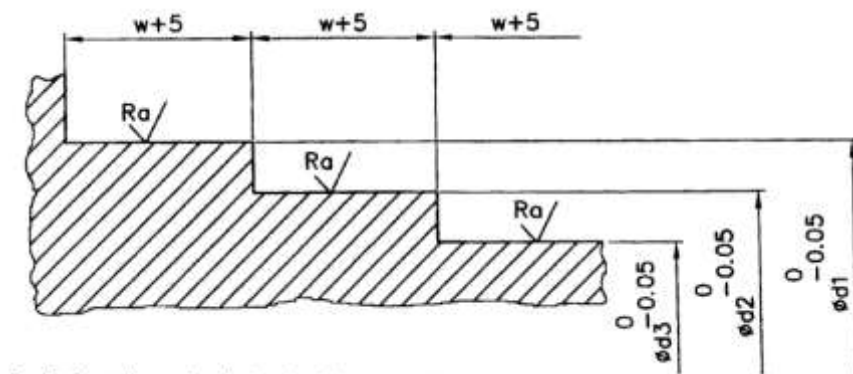

FIG. 26 TAPE DIMENSIONS



Ra — Surface roughness value at the discretion of the person checking.

FIG. 27 TAPE MANDREL

Table 18 Rim and Tape Widths
(Clauses 5.2.1 and A-4.1)

All Dimensions in millimetres

SI No. (1)	Rim Width (2)	Tape Width, $W_{-0.1}^0$ (3)
i)	18	16
ii)	20	18
iii)	22	20
iv)	24	22
v)	27	25
vi)	30.5	28.5

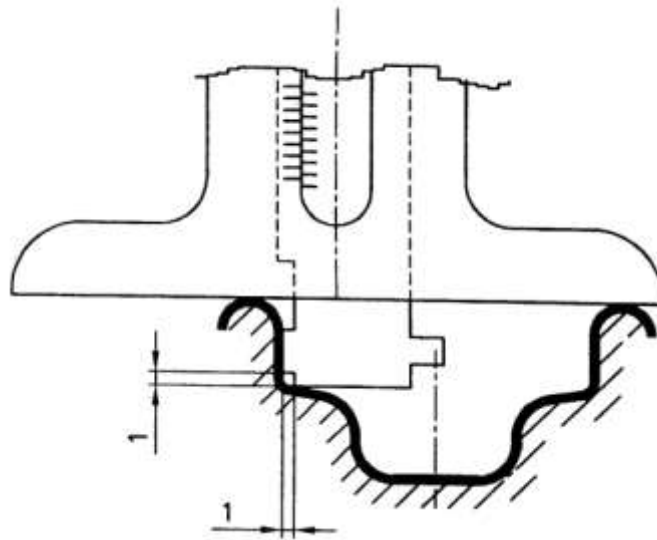

FIG. 28 VERNIER GAUGE WITH 1/20MM GRADUATIONS

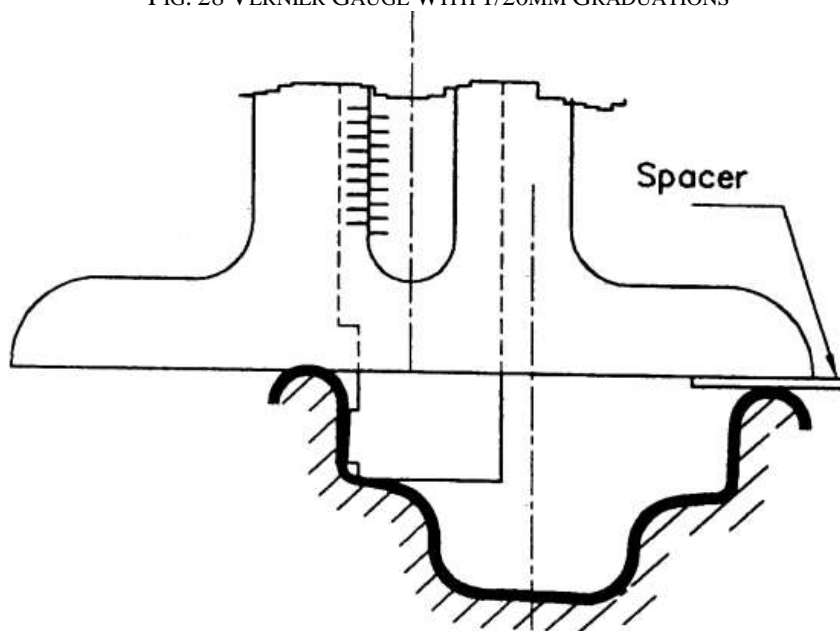

FIG. 29 USE OF VERNIER GAUGE WITH SPACER

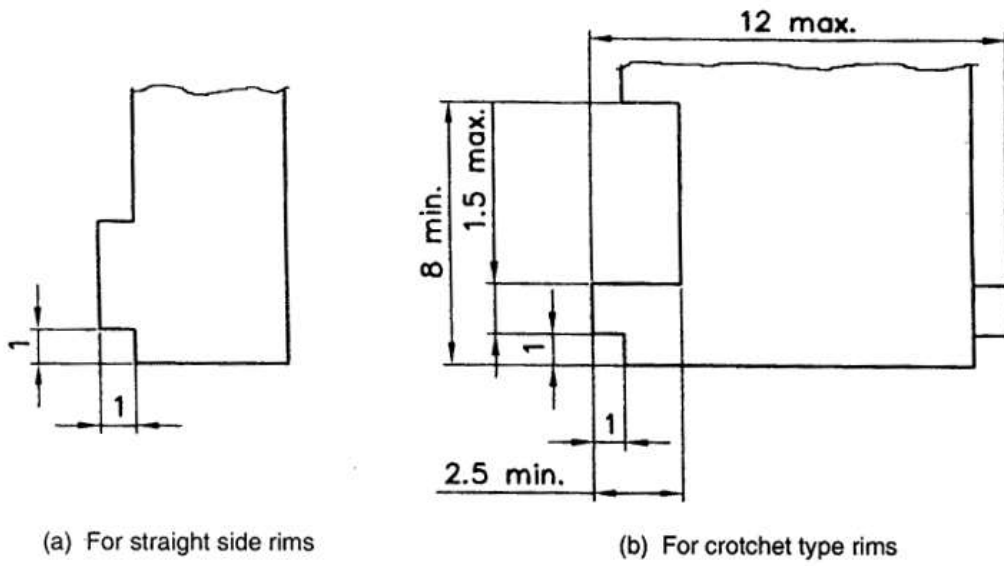

FIG. 30 VERNIER GAUGE DETAILS FOR MEASURING FLANGE HEIGHT, G

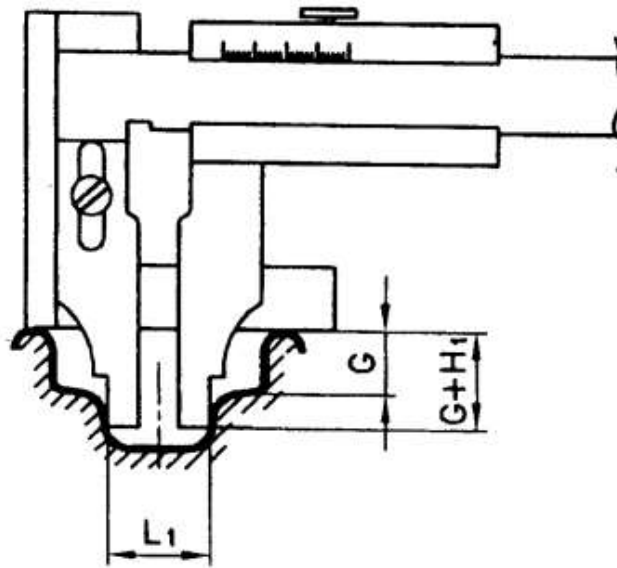

FIG. 31 MEASURING PRINCIPLE OF WELL WIDTH ABOVE RIM TAPE, L_1

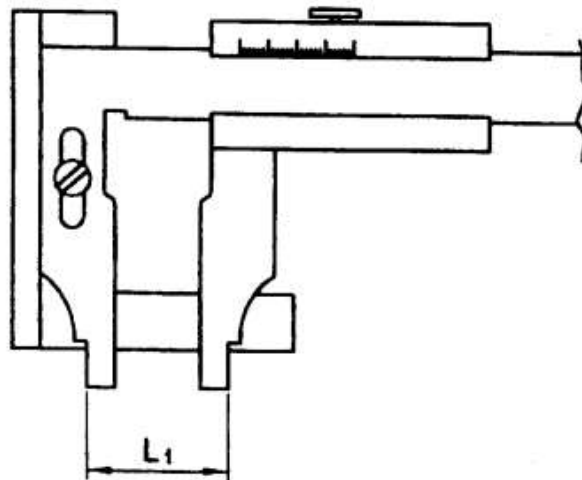

FIG. 32 CALLIPER VERNIER FOR MEASURING DIMENSION, L_1

A-5 MEASURING WELL WIDTH ABOVE RIM TAPE (see Fig.31 and Fig. 32)

A-6 MEASURING OF BEAD SEAT ANGLE 'B' (see Fig. 33 and Fig. 34)

A-7 MEASURING OTHER RIM DIMENSIONS

The rim width at the bead seat A_1 , and the specified rim width 'A' should be measured with a vernier calliper as illustrated in Fig. 35.

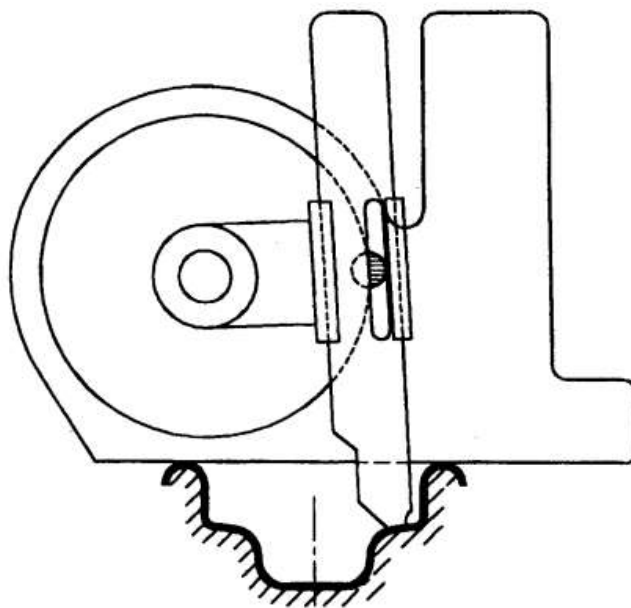

FIG. 33 MEASURING PRINCIPLE OF BEAD SEAT ANGLE 'B'

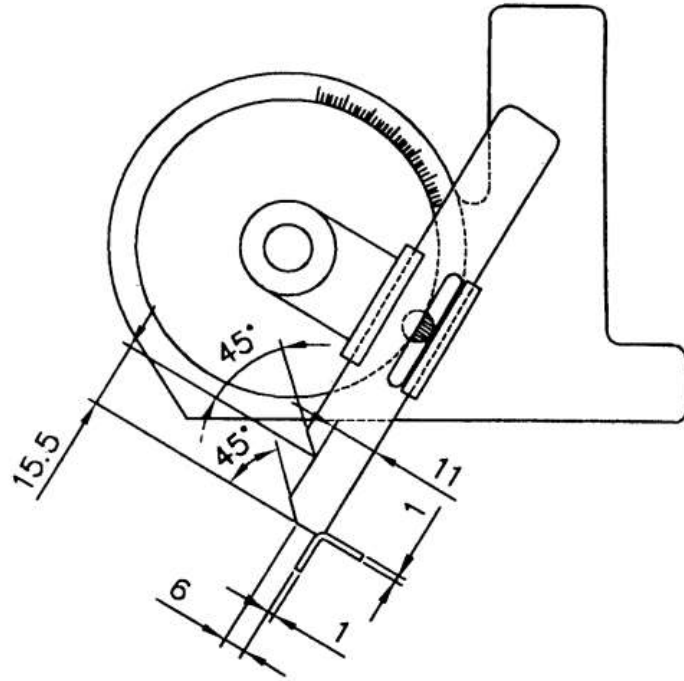

FIG. 34 TOOL FOR MEASURING ANGLE 'B'

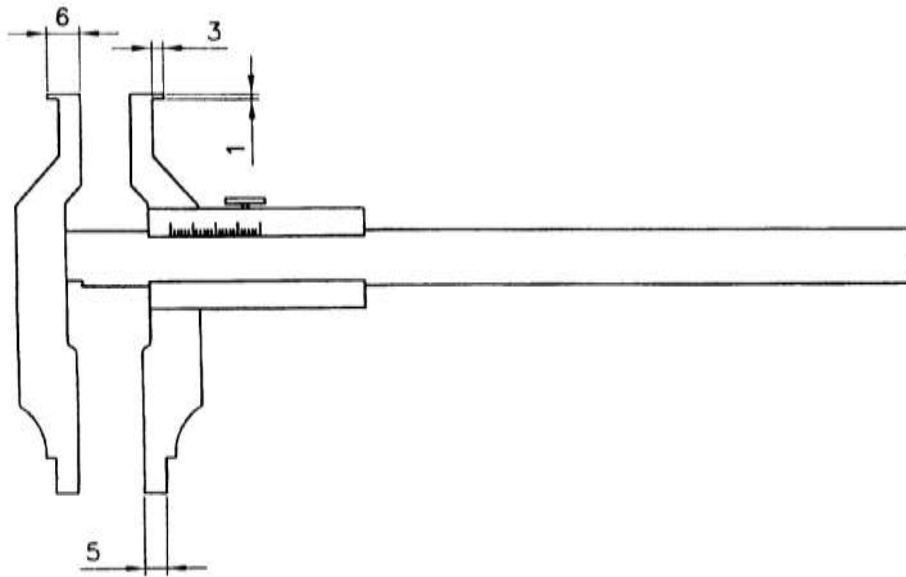

FIG. 35 VERNIER CALLIPER FOR MEASURING RIM WIDTH

Doc: TED 16 (24368) WC
IS 624: XXXX
April, 2024

ANNEX B
(Foreword)

COMMITTEE COMPOSITION

Bicycles Sectional Committee, TED 16
(Will be added later)