

For Comments Only

BUREAU OF INDIAN STANDARDS

DRAFT FOR COMMENTS ONLY

(Not to be reproduced without the permission of BIS or used as an Indian Standard)

भारतीय मानक मसौदा

स्वचालित वाहन — स्प्रे - दबाव पद्धति

Draft Indian Standard

Automotive Vehicles — Spray-Suppression Systems

ICS 43.020; 43.040

**Automotive Body, Chassis and Accessories Sectional Committee,
TED 06**

**Last date for receipt of
comments is 23/09/2024**

FOREWORD

(Formal clauses will be added later)

The spray suppression system is intended to reduce the water spray and/or mud thrown upwards and rearward by rear tyre of vehicle in motion.

In preparation of this standard considerable assistance has been derived from AIS-013 (Rev.1):2014 Automotive Vehicles - Spray-Suppression Systems.

The composition of the Committee responsible for formulating this standard is given in **Annex C (Will be added later)**.

In reporting the result of a test or analysis made in accordance with this standard, if the final value, observed or calculated, is to be rounded off, it shall be done in accordance with IS 2: 2022 'Rules for rounding off numerical values (*second revision*)'. This shall be given in standards on methods of test, Sampling, code of practice, etc.

Draft Indian Standard

Automotive Vehicles – Spray-Suppression Systems

1 SCOPE

1.1 This standard specifies the performance, dimensional and fitment requirements of spray-suppression systems in following category of automotive vehicles with the exception of off-road vehicles mentioned in IS 14272. In the case of chassis/cab vehicles, these requirements may only be applied to the wheels covered by the cab (i.e. fully built cab) and this is not applicable to vehicles with incomplete cab (i.e. cowl-chassis, front-end structure type cab).

1.2 All N, T3 and T4 category vehicles shall be constructed and/or fitted with spray-suppression devices in such a way as to meet the requirements of this standard.

1.3 Vehicles of category N1 and N2 with Gross Vehicle Weight (GVW) not exceeding 7.5 tonnes, complying the requirements of IS 13943, shall be deemed to meet the requirements of this standard.

1.4 The requirements laid down relating to spray-suppression devices as defined in 3.4 are not mandatory in the case of chassis/cab vehicles, un-bodied vehicles, in which the presence of spray-suppression devices is incompatible with their use. However, if such devices are fitted to these vehicles, they shall conform to the requirements of this standard.

2 REFERENCE

The following standards contain provisions which through reference in this text, constitute provision of this standard. At the time of publication, the editions indicated were valid. All standards are subject to revision, and parties to agreements based on this standard are encouraged to investigate the possibility of applying the most recent editions of the standards indicated below:

<i>IS/Other No.</i>	<i>Title</i>
IS 9211: 1979	Denominations and Definitions of Weights of Road Vehicles.
IS 13943: 1994	Automotive Vehicles — Wheel Guards for passenger cars — Performance Requirements
IS 14272: 2011	Automotive Vehicles — Types — Terminology (<i>First Revision</i>)

3 DEFINITIONS

For the purposes of this standard, the following definitions shall apply:

3.1 Spray-Suppression System

Spray-Suppression System means a system intended to reduce the pulverization of water thrown upwards by the tyres of a vehicle in motion. The spray-suppression system is variously made up of a mudguard, rain flaps and valances equipped with a spray-suppression device.

3.2 Mudguard

Mudguard means a rigid or semi-rigid component intended to trap the water thrown up by tyres in motion and to direct it towards the ground. Mudguards may entirely or partially form an integral part of the vehicle bodywork or other parts of the vehicle such as the lower part of the load platform, etc.

3.3 Rain flap

Rain flap means a flexible component mounted vertically behind the wheel, on the lower part of the chassis or the loading surface, or on the mudguard.

The rain flap shall also reduce the risk of small objects, in particular pebbles, being picked up from the ground by the tyres and thrown upwards or side wards towards other road users.

3.4 Spray-suppression device

Spray-suppression device means part of the spray-suppression system, which may comprise:

3.4.1 Air / water separator

Air / water separator This is a component forming part of the valance and /or of the rain flap through which air can pass whilst reducing pulverized water emissions.

3.4.2 Energy absorber

This is a component forming part of the mudguard and / or valance and /or rain flap which absorbs the energy of water spray, thus reducing pulverized water spray.

3.5 Outer Valance

Outer Valance means a component located approximately within a vertical plane that is parallel to the longitudinal plane of the vehicle. It may form part of a mudguard or of the vehicle bodywork.

3.6 Steered wheels

Steered wheels means the wheels actuated by the vehicle's steering system.

3.7 Self-tracking axle

Self-tracking axle means an axle pivoted about a central point in such a way that it can describe a horizontal arc. For the purpose of this Standard, a self-tracking axle of the 'pivot steering' type is considered to be, and treated as, an axle fitted with steered wheels.

3.8 Self-Steered Wheels

Self-steered wheels mean wheels not actuated by the vehicle's steering device, which may swivel through an angle not exceeding 20 °. owing to the friction exerted by the ground.

3.9 Lifting axle

Lifting axle means an axle, which can be lifted from the road during normal vehicle use.

3.10 Unladen vehicle

Unladen vehicle means a vehicle in the form given in **3.2** to **3.6** of IS 9211 depending on the configuration of the vehicle submitted for Type Approval of the spray-suppression device / system.

3.11 Tyre contact patch

Tyre contact patch means the part of the tyre, in contact with the road (surface), which provides grip.

3.12 Type of spray-suppression device

Type of spray-suppression device means devices which do not differ with respect to the following main characteristics:

- a) The physical principle adopted in order to reduce emissions (water energy absorption, air/water separator);
- b) Materials;
- c) Shape; and
- d) Dimensions (in so far as they may influence the behaviour of the material).

SECTION I

REQUIREMENTS RELATING TO THE COMPONENT TYPE-APPROVAL OF SPRAY-SUPPRESSION DEVICES

4 GENERAL SPECIFICATIONS

Spray-suppression devices shall be constructed in such a way that they operate properly when used normally on wet roads. Moreover, they shall incorporate no structural or manufacturing defect detrimental to their proper functioning or behaviour.

5 TESTS TO BE CARRIED OUT

Depending on their physical operating principle spray-suppression devices are subjected to the relevant tests as described in Annex A and B and shall deliver the results required in **A-4** and **B-4** of those Appendices.

6 APPLICATION FOR COMPONENT TYPE –APPROVAL

6.1 The application for component Type - Approval of a type of spray -suppression device shall be submitted by the manufacturer to the Test Agency.

6.2 For each type, the application shall be accompanied by the following documents in A4 or folded A4 size and the following information.

6.2.1 A technical description of the spray - suppression device indicating its physical operating principle and the relevant test to which it shall be subjected, the materials used and one or more drawings in sufficient detail and to an appropriate scale to enable this (or these) to be identified.

6.2.2 Four samples, shall be provided out of which three shall be used for tests and the fourth shall be kept by the Testing Agency for any subsequent verification. The Test Agency may require further samples.

7 Markings:

Each sample shall be clearly and indelibly marked with the trade name or mark and an indication of the type of the spray – suppression device by the letter ‘A’ or the letter ‘S’ depending on whether the device is of the energy absorption type (A) or of the air / water separator type (S).

7.1 *BIS Certification Marking*

The product(s) conforming to the requirements of this standard may be certified as per the conformity assessment schemes under the provisions of the *Bureau of Indian Standards Act, 2016* and the Rules and Regulations framed thereunder, and the products may be marked with the Standard Mark.

SECTION II

REQUIREMENTS RELATING TO THE TYPE-APPROVAL OF A TYPE OF VEHICLE WITH REGARD TO THE FITMENT OF SPRAY-SUPPRESSION SYSTEM

8 APPLICATION FOR TYPE – APPROVAL

8.1 The application for type - approval of a vehicle type with regard to the fitting of a spray -suppression system shall be submitted by the vehicle manufacturer.

8.2 It shall be accompanied by the following documents having the following particulars:

8.2.1 A technical description of the spray - suppression system and one or more sufficiently detailed drawing on a scale suitable for identification.

8.3 A vehicle representative of the vehicle type to be approved, fitted with its spray suppression system, shall be submitted to the Test Agency conducting the approval tests.

8.4 Criteria for Extension of Type Approval:

In the case of Type-Approval of a number of models /variants fitted with the spray suppression devices of the same type, the Type approval / extension of type approval may be granted if the following conditions are met:

TYPE APPROVAL / EXTENSION OF TYPE APPROVAL CONDITIONS

(clause 8.4)

Sr. No.	VARIATION	VEHICLE SELECTED FOR TEST
(1)	(2)	(3)
i)	Vehicle Specification	If all variants are of similar design in so far as components, fitting and attachments of the wheel guard, then only one vehicle will be tested
ii)	Wheel Size	Vehicle with single or twin wheels having the greatest width.
iii)	Peripheral clearance between mudguard and tyre tread	Largest clearance

9 GENERAL REQUIREMENTS

9.1 Axles

9.2 Lifting axles

Where a vehicle is fitted with one or more lifting axles, the spray suppression system shall cover all the wheels when the axle is lowered and the wheels in contact with the ground when the axle is raised.

9.3 Self-tracking axles

Where a vehicle is fitted with a self-tracking axle, the spray-suppression system shall satisfy the conditions applicable to non-steered wheels if mounted on the pivoting part. If not mounted on that part, it shall satisfy the conditions that are applicable to steered wheels.

10 POSITION OF OUTER VALANCE

10.1 In the case of non-steered wheels distance 'C' between the longitudinal plane tangential to the outer tyre wall, apart from any tyre bulge near the ground, and the inner edge of the valance shall not exceed 75 mm unless

the radius of the inner edge of the valance, as defined in 13.2, 14.2 and 15.2 is less than 1.0 R, in which case it shall not exceed 100 mm (*see* Fig. 1).

10.2 In the case of steered and self-steered wheels, distance 'C' shall not exceed 100 mm.

11 STATE OF VEHICLE

For the checking of compliance with this Standard the vehicle shall be in the following state:

- a) It shall be unladen and with the wheels in the straight-ahead position;
- b) In the case of semi-trailers, the loading surfaces shall be horizontal; and
- c) The tyres shall be inflated to their normal pressure.

12 SPRAY-SUPPRESSION SYSTEMS

12.1 The spray-suppression system shall meet the specifications set out in 13 or 15.

12.2 The spray-suppression system for non-steered or self-steered wheels that are covered by the bodywork floor, or by the lower part of the load platform, shall meet either the specifications set out in 13 or 15 or else those in 14.

13 Requirements Concerning Energy Absorption Spray Suppression Systems for Axles Fitted with Steered or Self Steering or Non-Steered Wheels

13.1 Mudguards

13.1.1 The mudguards shall cover the zone immediately above, ahead and behind the tyre or tyres in the following manner:

- a) In the case of a single or multiple axle where distance 'd' (*see* Fig. 4A and Fig. 4B) between the tyres fitted to the adjacent axles exceeds 300 mm, the forward edge (C) shall extend forwards to reach a line O – Z where angle (theta) = no more than 30 ° above the horizontal for axles fitted with steering or self-steering wheels, and no more than 20 ° for axles fitted with non-steered wheels. The rearmost edge (*see* Fig. 2) shall extend downwards in such a way as not to be more than 100 mm above a horizontal line passing through the centre of the wheel.
- b) In the case of multiple axles where the distance 'd' between the tyres fitted to the adjacent axles does not exceed 300 mm, the mudguard (*see* Fig. 4A).
- c) The mudguard shall possess a total width 'q' (*see* Fig. 1) at least adequate to cover the entire width of the tyre 'b' or the entire width of two tyres 't' in the case of twin wheels, account being taken of the extremes for the tyre/wheel unit specified by the manufacturer. Dimensions 'b' and 't' shall be measured at hub height, excluding any markings, ribs, protective bands, etc., on the tyre walls.

13.1.2 The front side of the rear part of the mudguard shall be fitted with a spray reduction device complying with the specifications set out in ANNEX A. This material shall cover the inside of the mudguard up to a height determined by a straight line running from the centre of the wheel and forming an angle of at least 30 ° with the horizontal (*see* Fig. 3).

13.1.3 If the mudguards are made up of several components when fitted, they shall not incorporate any aperture enabling spray to exit while the vehicle is in motion.

13.2 OUTER VALANCES

13.2.1 In the case of single axles, or multiple axles where distance 'd' between the tyres on adjacent axles exceeds 300 mm, the lower edge of the outer valance may not be situated beyond the following distances and radii, as measured from the centre of the wheel (*see* Fig. 2).

- a) Axles fitted with steered wheels or self-steering wheels;
From the front edge (towards the front of the vehicle) (tip C at 30 °) $R_v \leq 1.5 R$

To the rear edge (towards the rear of the vehicle) (tip A at 100 mm)

b) Axles fitted with non-steered wheels:

From the front edge (tip C at 20 °) To the rear edge (tip A at 100 mm) $R_v \leq 1.25 R$

Where R is the radius of the tyre fitted to the vehicle, and R_v the distance, expressed as a radius, at which the lower edge of the outer valance is situated.

13.2.2 In the case of multiple axles where distance 'd' between the tyres on adjacent axles does not exceed 300 mm, the outer valances located in the space between the axles shall be located at the distances set out in **13.2.1** and shall extend downwards in such a way as not to be more than 150 mm above a horizontal line passing through the centre of the wheels, or in such a way that the horizontal distance between their lower extremities do not exceed 60 mm (*see* Fig. 4A).

13.2.3 The depth of the outer valance shall extend to not less than 45 mm, at all points behind a vertical line passing through the centre of the wheel. The depth of the valances may be gradually reduced in front of this line.

13.2.4 No openings enabling spray to emerge when the vehicle is moving are allowed in the outer valances or between the outer valances and the other parts of the mudguards.

13.3 Rain Flaps

13.3.1 The width of the flap shall fulfil the requirement for 'q' in **13.1.1 (C)** except where the flap is within the mudguards, in which case it shall be at least equal in width to the tread of the tyre.

13.3.2 The orientation of the flap shall be basically vertical.

13.3.3 The maximum height of the bottom edge shall not exceed 200 mm (*see* Fig. 3). This distance is increased to 300 mm in the case of the last axle where the radial distance of the lower edge of the outer valancing, R_v does not exceed the dimensions of the radius of the tyres fitted to the wheels on that axle.

13.3.4 The rain flap shall not be more than 300 mm from the rearmost edge of the tyre, measured horizontally.

13.3.5 In the case of multiple axles where distance 'd' between the tyres on adjacent axles is less than 250 mm, only the rear set of wheels shall be fitted with rain flaps. There shall be a rain flap behind each wheel when distance 'd' between the tyres on adjacent axles is at least 250 mm (*see* Fig. 4B).

13.3.6 Rain flap shall not be deflected by more than 100 mm towards the rear under a force of 3 N per 100 mm of flap width, applied to a point located 50 mm above the lower edge of the flaps.

13.3.7 The whole of the front face of the part of the rain flap having the minimum dimensions required shall be fitted with a spray-suppression device that meets the specifications set out in ANNEX A.

13.3.8 No openings enabling spray to emerge are allowed between the lower rear edge of the mudguard and the rain flaps.

13.3.9 Where the spray-suppression device meets the specifications relating to rain flaps as mentioned in **13.3**, no additional rain flap is required.

14 REQUIREMENTS RELATING TO SPRAY SUPPRESSION SYSTEMS FITTED WITH ENERGY ABSORPTION SPRAY-SUPPRESSION DEVICES FOR CERTAIN AXLES THAT ARE FITTED WITH NON-STEERED OR SELF-STEERING WHEELS (*see* 12.2)

14.1 Mudguards

14.1.1 Mudguards shall cover the zone immediately above the tyre or tyres. Their front and rear extremities shall extend at least to the horizontal plane that is tangent to the upper edge of the tyre or tyres (*see* Fig. 5). However,

the rear extremity may be replaced by the rain flap, in which case this shall extend to the upper part of the mudguard (or equivalent component).

14.1.2 All of the inner rear part of the mudguard shall be fitted with a spray-suppression device that meets the requirement set out in ANNEX A.

14.2 Outer Valances

14.2.1 In the case of single or multiple axles where the distance between the adjacent tyres is at least 250 mm, the outer valance shall cover the surface extending from the lower to the upper part of the mudguard up to a straight line formed by the tangent to the upper edge of the tyre or tyres and lying between the vertical plane formed by the tangent to the front of the tyre and the mudguard or rain flap located behind the wheel or wheels (*see* Fig. 5B).

In the case of multiple axles, an outer valance shall be located by each wheel.

14.2.2 No openings enabling spray to emerge are allowed between the outer valance and the inner part of the mudguard.

14.2.3 Where rain flaps are not fitted behind each wheel (*see* 13.3.5), the outer valance shall be unbroken between the outer edge of the rain flap to the vertical plane that is tangent to the point furthest to the front of the tyre (*see* Fig. 5A) of the first axle.

14.2.4 The entire inner surface of the outer valance, the height of which shall not be less than 100 mm, shall be fitted with an energy-absorption spray suppression device complying with the requirements of Section 1.

14.3 Rain Flaps

These flaps shall extend to the lower part of the mudguard and comply with 13.3.

15 REQUIREMENTS CONCERNING SPRAY-SUPPRESSION SYSTEMS FITTED WITH AIR/WATER SEPARATOR SPRAYSUPPRESSION DEVICES FOR AXLES WITH STEERED AND NON-STEERED WHEELS

15.1 Mudguards

15.1.1 Mudguards shall comply with the requirements of 13.1.1(c).

15.1.2 Mudguards for single or multiple axles where the distance between the tyres on adjacent axles exceeds 300 mm shall also comply with item 13.2.1 (a).

15.1.3 In the case of multiple axles where the distance between the tyres on adjacent axles does not exceed 300 mm, the mudguards shall also conform to the model (*see* Fig. 7).

15.2 Outer Valances

15.2.1 The lower edges of the outer valances shall be fitted with air/water separator spray-suppression devices complying with the requirements of Section 1.

15.2.2 In the case of single or multiple axles where the distance between the tyres on adjacent axles exceeds 300mm, the lower edge of the spray suppression device fitted to the outer valance shall have the following maximum dimensions and radii, starting from the centre of the wheel (*see* Fig. 6 and 7):

Axles fitted with steered wheels or self-steering wheels:

From the front edge (towards the front of the vehicle) $R_v \leq 1.05 R$
(tip C at 30 °) to the rear edge (towards the rear of the vehicle) (tip A at 100 mm).

Axles fitted with non-steered wheels;

From the front edge (tip C at 20 °) to the rear edge (tip A at 100 mm) $R_v \leq 1.00 R$

Where

R = is the radius of tyre fitted to the vehicle;

R_v = the radial distance from the lowest edge of the outer valance to the centre of the wheel.

15.2.3 In the case of multiple axles where the distance between the tyres on adjacent axles does not exceed 300 mm, the outer valances located in the inter-axle spaces shall follow the path specified in **15.1.3**, and shall extend downwards in such a way as not to be more than 100 mm above a horizontal straight line passing through the wheel centers (*see* Fig. 7).

15.2.4 The depth of the outer valance shall extend to not less than 45 mm, at all points behind a vertical line passing through the centre of the wheel. This depth may be gradually reduced in front of this line.

15.2.5 No openings enabling spray to emerge are allowed in the outer valances or between the outer valances and the mudguards.

15.3 Rain Flaps

15.3.1 Rain flaps shall:

- a) Comply with Para **13.3** (Figure 3); or
- b) Comply with Para **13.3.1**, **13.3.5**, **13.3.8** and **15.3.2** (*see* Fig. 6).

15.3.2 Spray suppression device complying with the specifications set out Annex B, shall be fitted to the rain flaps referred to in **15.3.1 (b)**, at least along the full edge.

15.3.2.1 The lower edge of the spray-suppression device shall be not more than 200 mm from the ground.

15.3.2.2 The spray suppression device shall be at least 100 mm deep.

15.3.2.3 Apart from the lower part, which includes the spray-suppression device, the rain flap as referred to in **15.3.1 (b)** shall not bend by more than 100 mm towards the rear under the effect of a force of 3 N per 100 mm of width of the rain flap measured at the intersection of the rain flap with the spray-suppression device in its working position, applied at a distance of 50 mm above the lower edge of the rain flap.

15.3.2.4 The rain flap shall not be more than 200 mm from the rearmost edge of the tyre, measured horizontally.

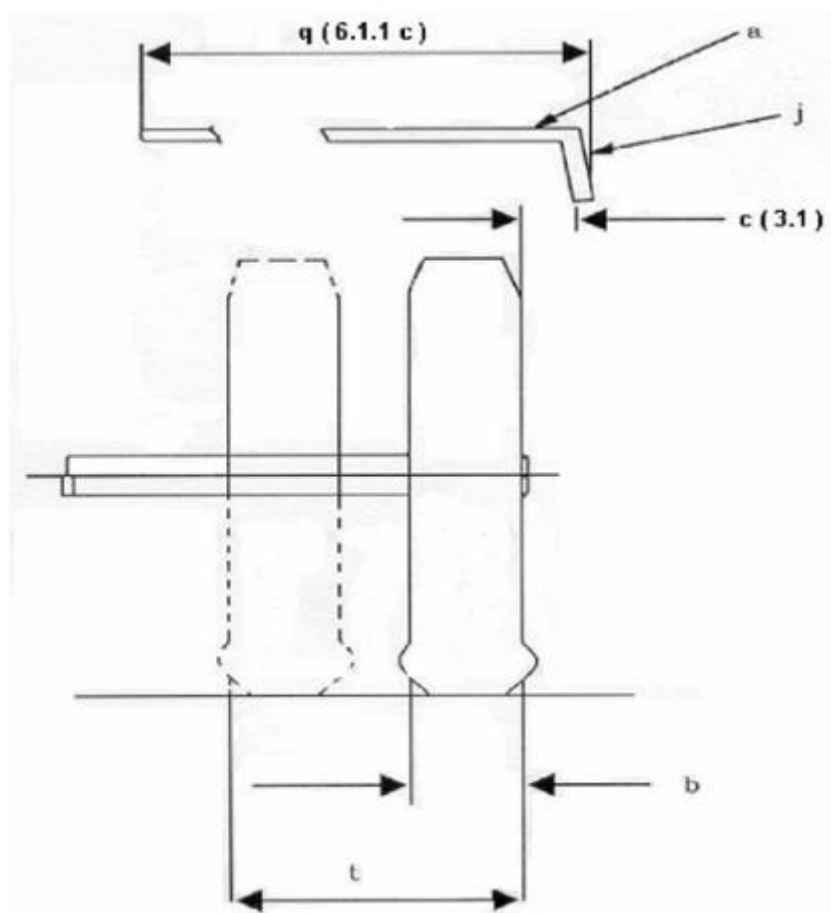

FIG. 1 WIDTH (q) OF WIDTH (a) AND POSITION OF VALANCE (j)

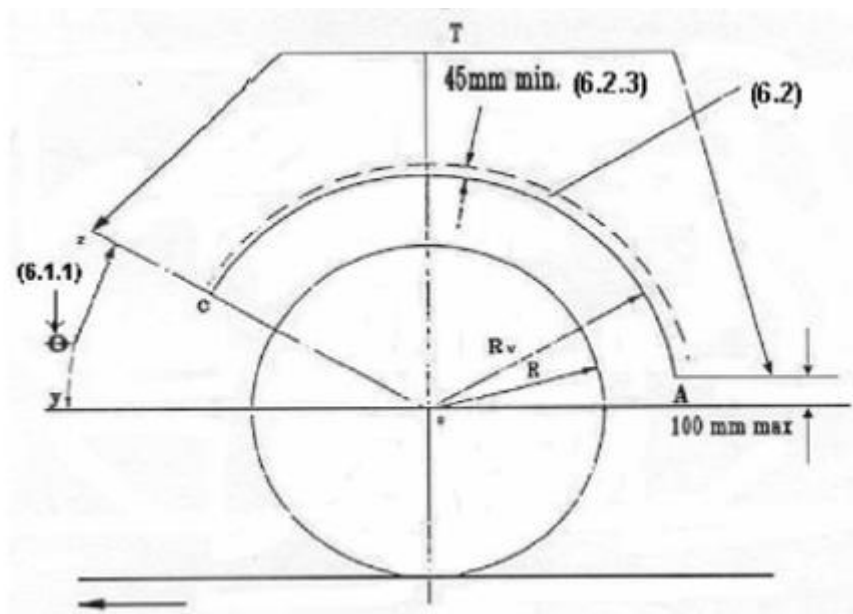

FIG. 2 DIMENSIONS OF MUDGUARD AND OUTER VALANCE

NOTE — T: extent of mudguard.

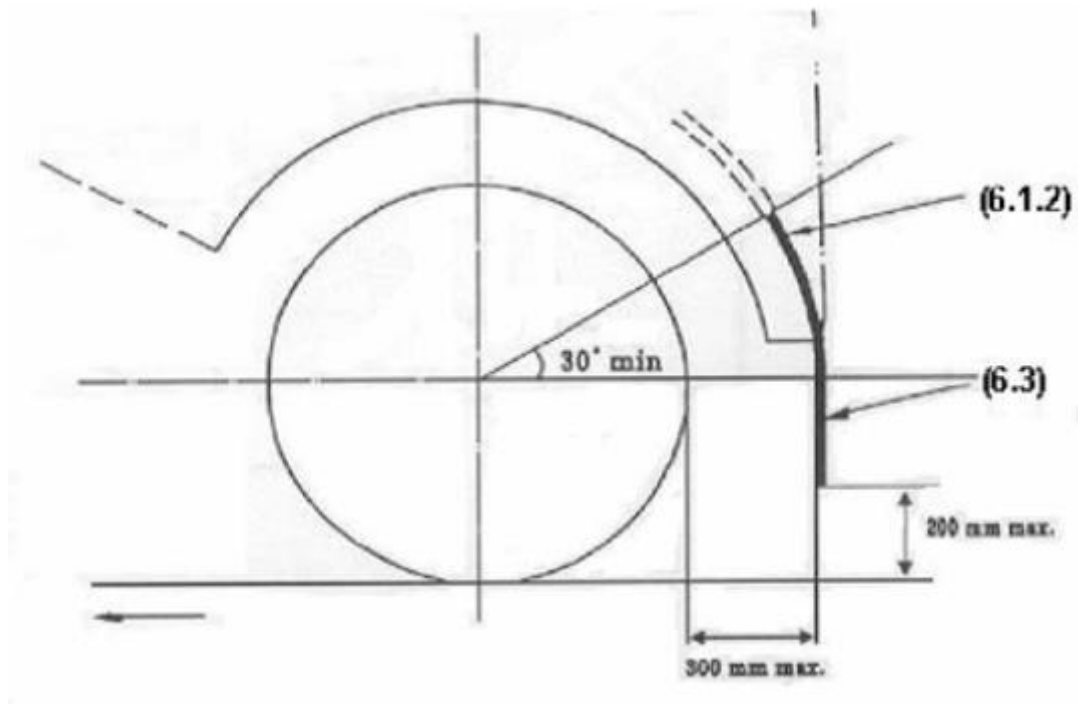

FIG. 3 POSITON OF MUDGUARD AND RAIN FLAP

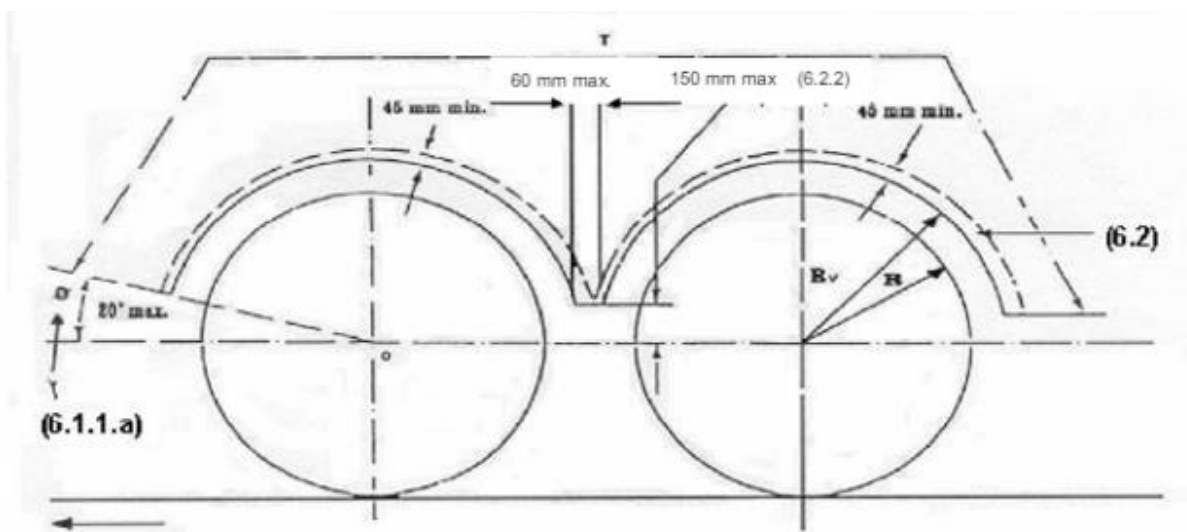

FIG. 4A DIMENSIONS OF MUDGUARDS AND OUTER VALANCES FOR MULTIPLE AXELS

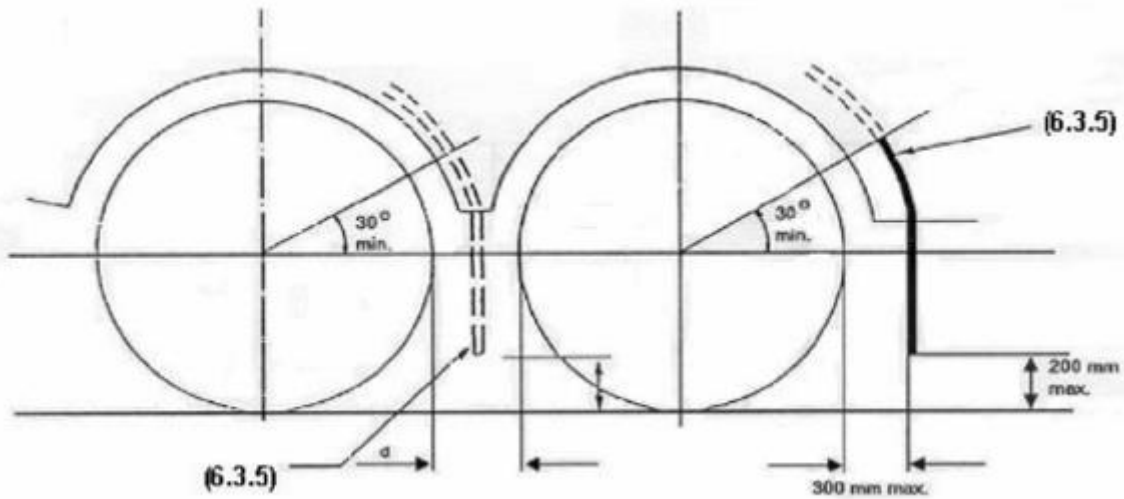

FIG. 4B POSITION OF SPAY-SUPPRESSION DEVICES FOR MULTIPLE AXLES

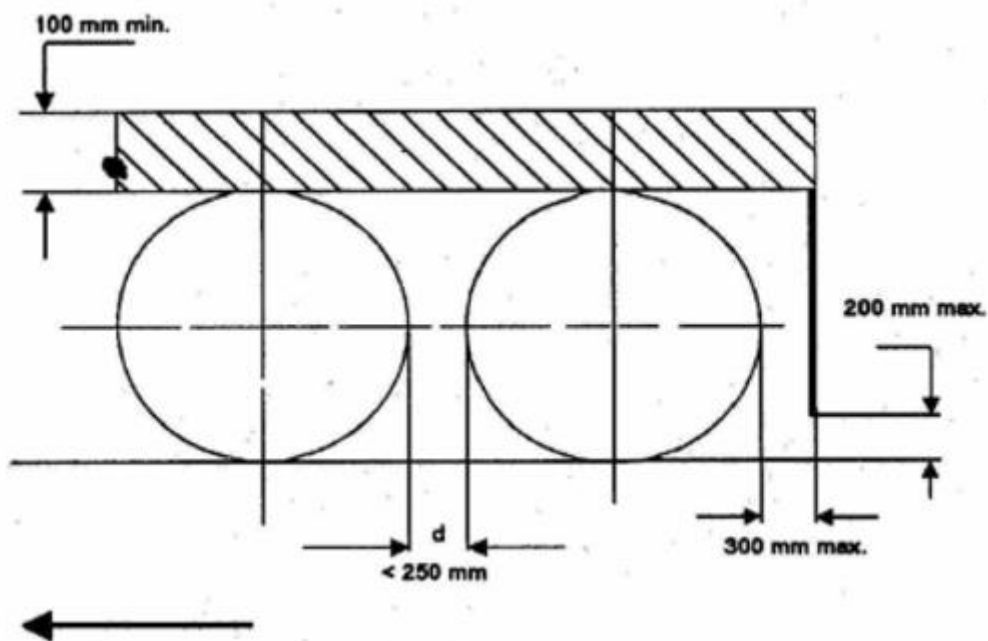

FIG. 5A MULTIPLE AXLES WHERE THE DISTANCE BETWEEN THE TYRE IN LESS THAN 250 MM

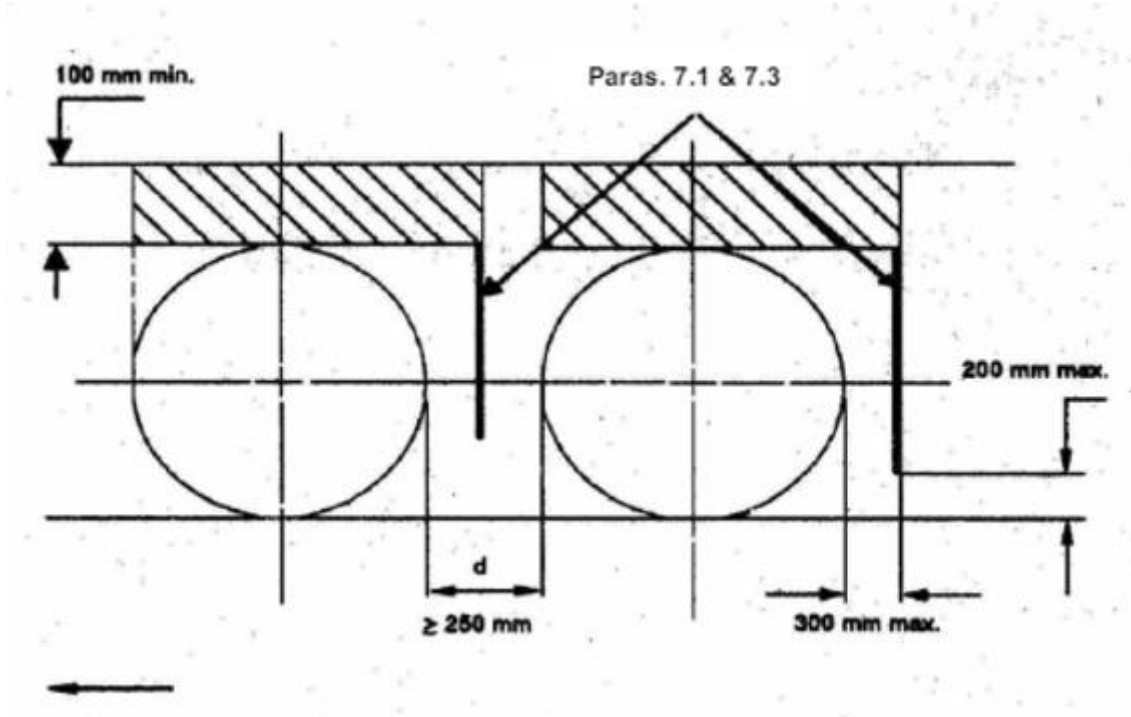

FIG. 5B SINGLE AXLES OR MULTIPLE AXLES WHERE THE DISTANCE THE TYRES IN NOT LESS THAN 250 MM

FIG. 5 DIAGRAM SHOWING ASSEMBLY OF A SPAY-SUPPRESSION SYSTEM INCORPORATING SPAY-SUPPRESSION DEVICES FITTED WITH ENERGY ABSORBERS FOR AXLES FITTED WITH NON-STEERING OR SELF-STEERING WHEELS

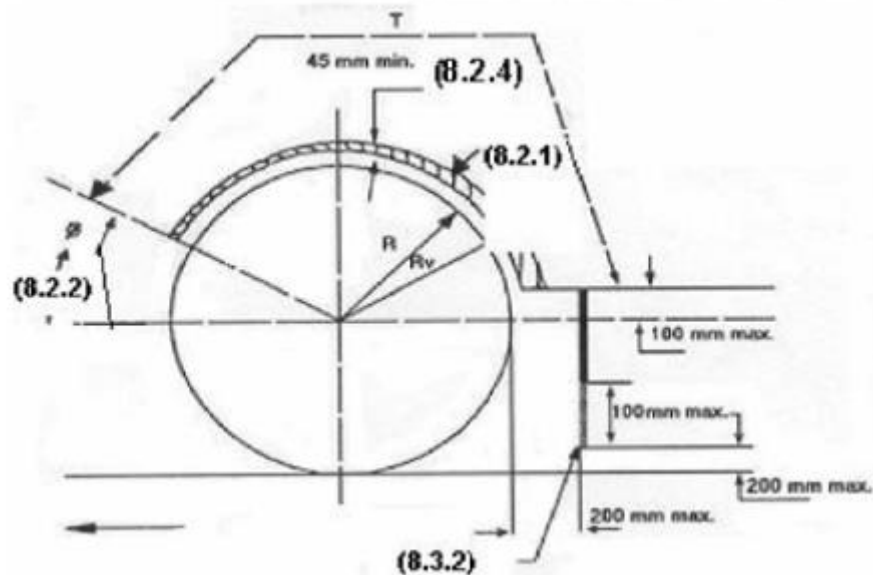
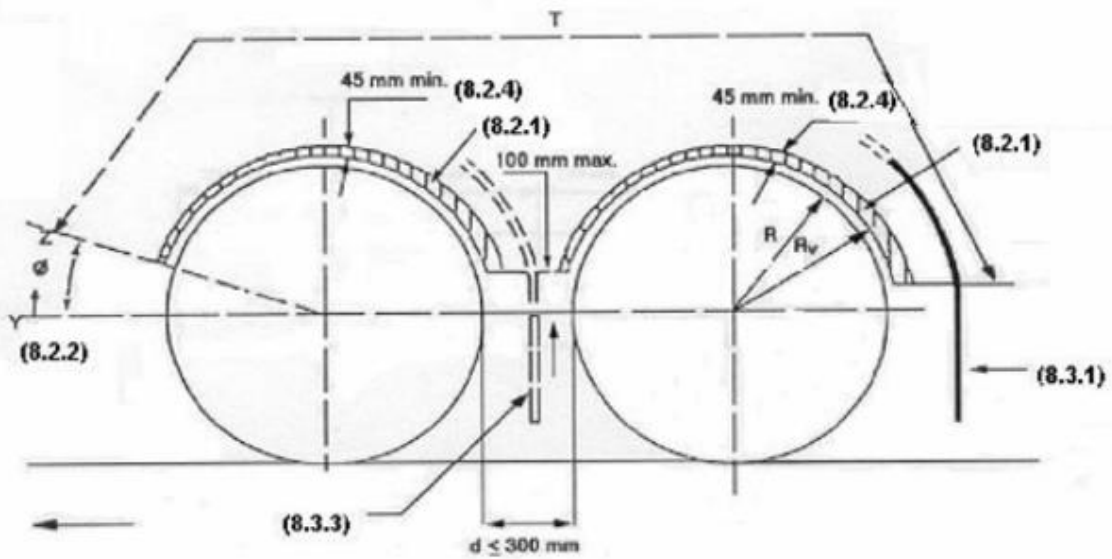

FIG. 6 DIAGRAM SHOWING ASSEMBLY OF A SPAY-SUPPRESSION SYSTEM INCORPORATING SPRAY-SUPPRESSION DEVICES FITTED WITH AIR/WATER SEPARATORS FOR AXLES FITTED WITH STEERED, SELF-STEERING OR NON-STEERED WHEELS

NOTE — T: extent of mudguard.



NOTE — T: extent of mudguard.

FIG. 7 DIAGRAM SHOWING ASSEMBLY OF A SPAY-SUPPRESSION SYSTEM INCORPORATING SPAY-SUPPRESSION DEVICES (MUDGUARD, RAIN FLAP, OUTER VALANCE) FOR MULTIPLE AXLES WHERE THE DISTANCE BETWEEN THE TYRES DOES NOT EXCEED 300 MM

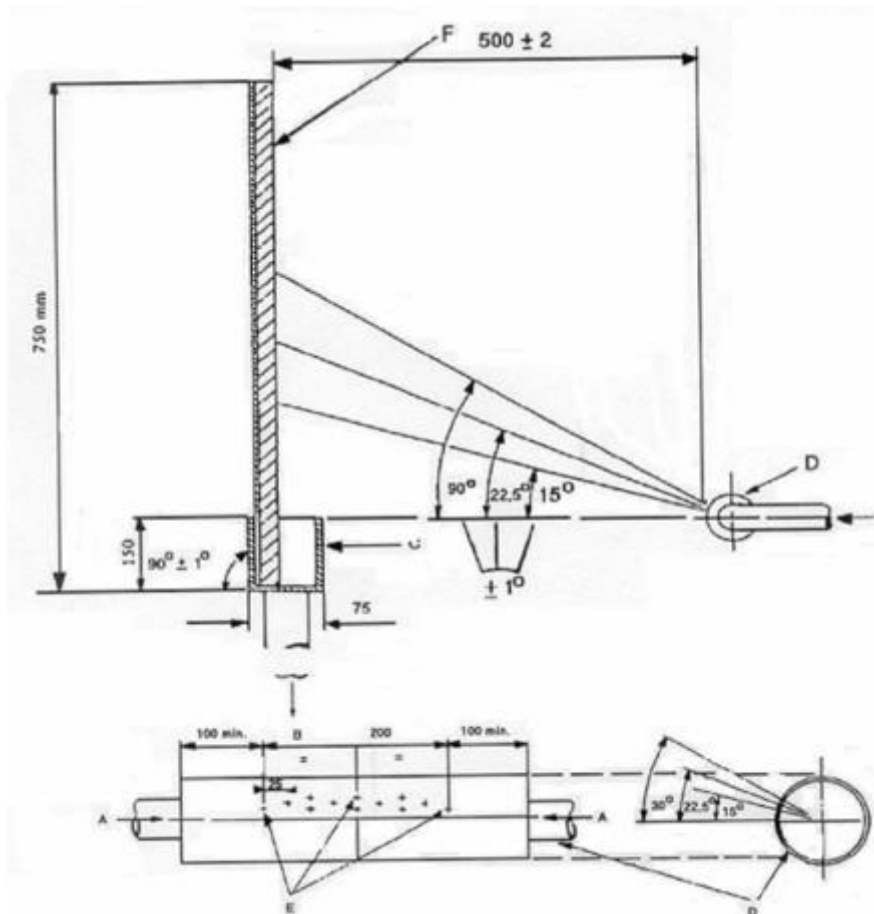

All linear dimensions are in millimeter

FIG. 8 TEST ASSEMBLY FOR ENERGY ABSORPTION SPRAY-SUPPRESSION DEVICES

NOTES

- A= Water supply from pump;
- B= Flow towards collector tank;
- C= Collector with inside dimension of 500 (+ 5/ -0) mm width;
- D = Thin-wall, 54 mm diameter pipe;
- E = 12 holes drilled radially as shown, diameter 1.68 (+ 0.025/ -0) mm; and
- F= 500 (+0; -5) mm wide sample to be tested.

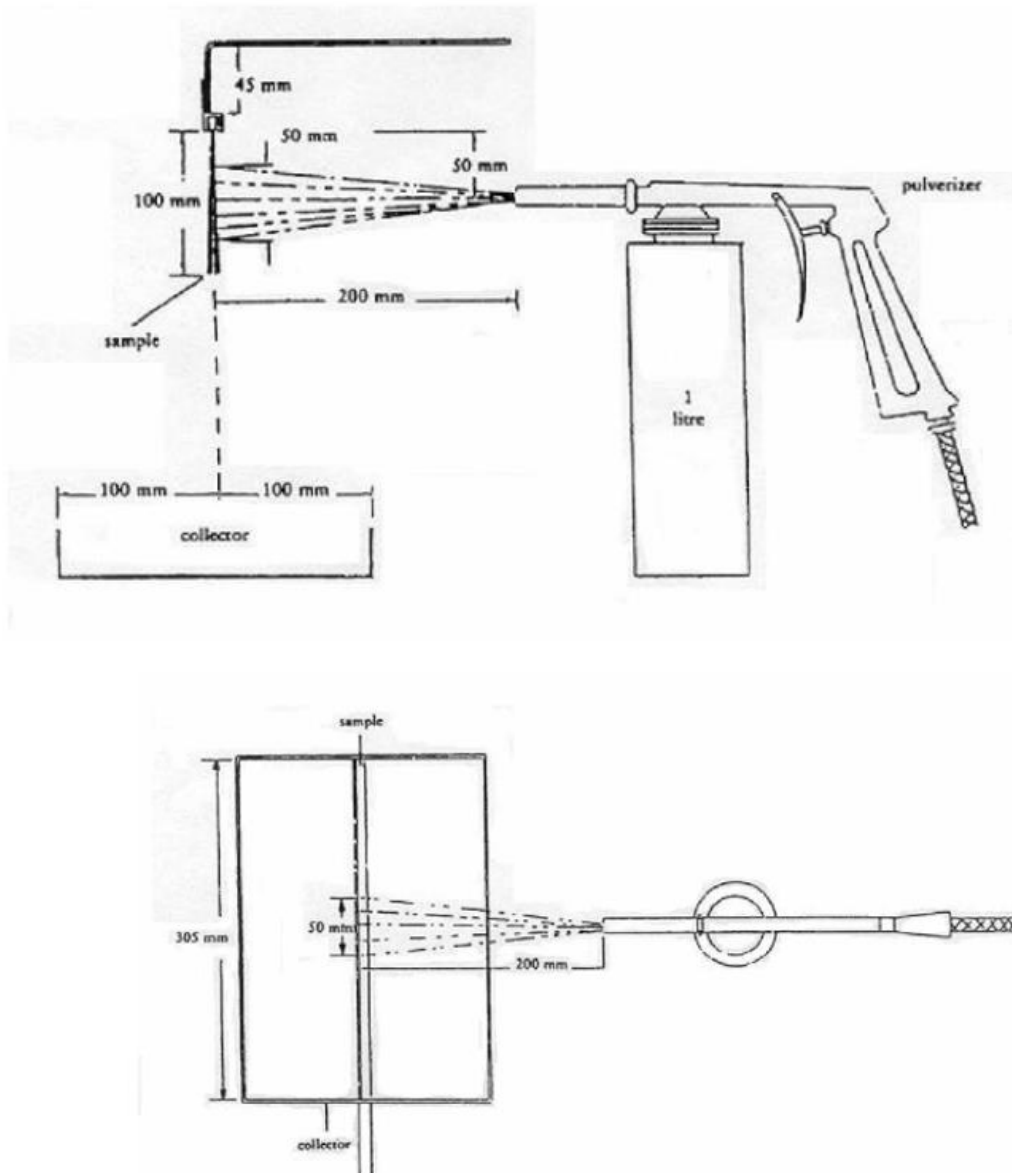

FIG. 9 TEST ASSEMBLY FOR AIR/WATER SEPARATOR SPRAY-SUPPRESSION DEVICES (SEE B-2.1)

ANNEX A
(Clause 3.1, 12, 20.2.2, 20.4.9 and 21.1.2)

TESTS ON SPRAY-SUPPRESSION DEVICES OF THE ENERGY-ABSORBER TYPE

A-1 PRINCIPLE

The aim of these tests is to quantify the ability of a device to retain the water directed against it by a series of jets. The test assembly is intended to reproduce the conditions under which the device is to function when fitted to a vehicle as regards the volume and speed of the water thrown up from the ground by the tyre tread.

A-2 EQUIPMENT

For description of the test assembly (*see* Fig. 8). The tests are carried out in a still-air environment.

A-3 PROCEDURE

A-3.1 Secure a 500 (+0 / -5) mm wide, 750 mm high sample of the device to be tested to the vertical frame of the testing equipment, making sure that the sample lies well within the limits of the collector, and that no obstacle is able to deflect the water, either before or after its impact.

A-3.2 Set the water flow rate at 0.675 (± 0.01) l/s and direct at least 90 l on to the sample from a horizontal distance of 500 (± 2) mm (*see* Fig. 8).

A-3.3 Allow the water to trickle from the sample into the collector and calculate the percentage (difference) between the quantity of water collected and the quantity of water sprayed.

A-3.4 Repeat the test five times and calculate the average percentage amount of water collected.

A-4 RESULTS

A-4.1 The calculated average percentage of water collected during the five tests shall not be less than 70% of the amount of water directed on to the device.

A-4.2 If the highest and lowest percentages of water collected depart from the average percentage by more than 5%, the test is not valid and must be repeated

If even in the second test the highest and lowest percentages of water recovered again depart from the average percentage by more than 5% and/or if the lower value does not satisfy the requirements of item **A-4.1**, approval is refused.

A-4.3 Where the vertical position of the device influences the results obtained, the procedure described in items **A-3.1** and **A-3.4** shall be repeated in the positions giving the highest and lowest percentage of water collected the requirements of **A-4.2** remain in force.

The requirements of item **A-4.1** remain in force in order to give the result of each test.

ANNEX B
(Clause 3.1 and 22.4.2)

TEST ON SPRAY-SUPPRESSION DEVICES OF THE AIR / WATER SEPARATOR TYPE

B-1 PRINCIPLE

B-1.1 This test is intended to determine the effectiveness of a porous material intended to retain the water with which it has been sprayed by means of a pressurized air/water pulverizer.

B-1.2 The equipment used for the test shall simulate the conditions to which the material would be submitted, with regard to the volume and speed of the water spray produced by the tyres, if it were fitted to a vehicle.

B-2 EQUIPMENT

B-2.1 The test assembly is as described in Figure 9.

B-3 PROCEDURE

B-3.1 Secure a 305 x 100 mm sample vertically in the test assembly; check that there is no space between the sample and the upper curved plate and that the tray is properly in position. Fill the pulverizer tank with exactly one liter of water and place this as described in the diagram.

B-3.2 The pulverizer shall be regulated as follows:

Pressure (at pulverizer): 5 bar + 10% / - 0%

Flow rate: 1 litre / minute + 5 seconds

Pulverization: Circular, roughly 50 mm in diameter at 200 mm from the sample, nozzle 5 mm in diameter.

B-3.3 Pulverize until there is no more water mist and note the time taken. Let the water flow out of the sample on to the tray for 60 seconds and measure the volume of water collected. Measure the quantity of water left in the pulverizer tank. Calculate the percentage by volume of water collected versus the volume of water pulverized.

B-3.4 Repeat the test five times and calculate the average percentage of the quantity collected. Check before each test that the tray, pulverizer tank and measuring vessel are dry.

During the test the ambient temperature shall be 27 (± 5) °C.

B-4 RESULTS

B-4.1 The calculated average percentage of water collected at the end of five tests shall not be less than 85% of the quantity of water sprayed on to the device.

B-4.2 If the highest and lowest percentages of water collected vary by more than 5% of the average percentage, the test is not valid and shall be repeated.

If even in the second test, the highest and lowest percentages of water recovered again depart from the average percentage by more than 5% and/or if the lower value does not satisfy the requirements of **B-4.1**, approval is refused.

B-4.3 Where the vertical position of the device influences the results obtained, the procedure described in **B-3.1** and **B-3.4** shall be repeated in the positions giving the highest and lowest percentages of water collected; the requirements of **B-4.2** remain in force

The requirement of **B-4.1** remains in force in order to give the results of each test

ANNEX C
(Foreword)

COMMITTEE COMPOSITION

Automotive Body, Chassis and Accessories Sectional Committee, TED 06

Will be added later