

BUREAU OF INDIAN STANDARDS

DRAFT FOR COMMENTS ONLY

(Not to be reproduced without permission of BIS or used as an Indian Standard)

भारतीय मानक प्रारूप

**सड़क वाहन – संपीडित प्राकृतिक गैस (सी एन जी) ईंधन प्रणाली के
घटक - कार्यकारिता एवं सामान्य परीक्षण पद्धतियाँ
(प्रथम संशोधन)**

Draft Indian Standard

**ROAD VEHICLES – COMPRESSED NATURAL GAS (CNG) FUEL SYSTEM
COMPONENTS – PERFORMANCE AND GENERAL TEST METHODS
(First Revision)**

ICS 43.060.40

Not to be reproduced without permission
of BIS or used as standard

Last date for receipt of comments
is 27/02/2023

Automotive Vehicles Running on Non-Conventional Energy Sources Sectional Committee,
TED 26

FOREWORD

(Formal Clause to be added later)

This Indian Standard was adopted by the Bureau of Indian Standards, after the draft finalized by the Automotive Vehicles Running on Non-conventional Energy Sources Sectional Committee had been approved by the Transport Engineering Division Council.

This standard was first published in 2006 to specify performance and general test methods for CNG on board fuel system components, intended for use on motor vehicles defined in IS 14272. In this Revision, Bio-CNG is added to the scope of this standard keeping in view the technological advancements that have taken place since its last Publication. The revised version also incorporates the Amendment issued to the standard in 2012.

In the formulation of this standard considerable assistance has been derived from the following standards issued by the Automotive Research Association of India and the International Organization for Standardization respectively:

AIS 024(Rev.1) (Part A):- Safety and Procedural Requirements for Type Approval of Gaseous Fuelled Vehicles - Part A (Automotive Application).

AIS 024(Rev.1) (Part B):- Safety and Procedural Requirements for Type Approval of Gaseous Fuel Agricultural Tractors - Part B (Agricultural Tractors Application).

AIS 024(Rev.1) (Part C):- Safety and Procedural Requirements for Type Approval of Gaseous Fuel Vehicles - Part C (CEV's Application).

AIS 028(Rev.1) (Part A):-Code of Practice for Use of Gaseous Fuels in Internal Combustion Engine Vehicles - Part A (Automotive Application)

AIS 028(Rev.1) (Part B):-Code of Practice for Use of Gaseous Fuels in Internal Combustion Engine Agricultural Tractors - Part B (Agricultural Tractors Application)

AIS 028(Rev.1) (Part C):-Code of Practice for Use of Gaseous Fuels in Internal Combustion Engine Construction Equipment Vehicles (CEV's) - Part C (CEV's Application).

ISO 15500-2:2001 'Road vehicles — Compressed natural gas (CNG) fuel system components — Part 2: Performance-of general test methods'

Considering Indian climatic conditions the Committee responsible for the formulation of this standard decided to deviate from the requirement of ISO with respect to the following:

- a) Components shall be tested at a temperature of -20° instead of -40°C , and
- b) Testing at room temperature shall be done at $27\pm 5^{\circ}\text{C}$ instead of $20\pm 5^{\circ}\text{C}$.

This standard is one of the series of Indian Standards published on CNG/Bio-CNG onboard fuel system components. Other standards in the series are:

<i>IS No.</i>	<i>Title</i>
15710: XXXX ¹	Road vehicles - Compressed natural gas (CNG) /Bio-Compressed natural gas (Bio-CNG) fuel system components – General requirements & definition.
15712: XXXX ¹	Road vehicles - Compressed natural gas (CNG) /Bio-Compressed natural gas (Bio-CNG) fuel system components – Automatic valve
15713: XXXX ¹	Road vehicles - Compressed natural gas (CNG) /Bio-Compressed natural gas (Bio-CNG) fuel system components – Pressure regulator
15714: XXXX ¹	Road vehicles - Compressed natural gas (CNG) /Bio-Compressed natural gas (Bio-CNG) fuel system components – Gas Air mixer
15715: XXXX ¹	Road vehicles - Compressed natural gas (CNG) /Bio-Compressed natural gas (Bio-CNG) / Liquefied Petroleum Gas (LPG) Fuel system components – CNG/Bio-CNG/LPG Conduit (Ventilation Hose/Pipe)
15716: XXXX ¹	Road vehicles - Compressed natural gas (CNG) /Bio-Compressed natural gas (Bio-CNG) fuel system components – CNG / Bio-CNG high pressure fuel line (rigid) with end connections (having pressure exceeding 2.15 MPa)
15717: XXXX ¹	Road vehicles - Compressed natural gas (CNG) /Bio-Compressed natural gas (Bio-CNG) / Liquefied Petroleum Gas (LPG) Fuel system components – Petrol valve (Automatic/Manual)
15718: XXXX ¹	Road vehicles - Compressed natural gas (CNG) /Bio-Compressed natural gas (Bio-CNG) fuel system components – CNG/Bio-CNG high Pressure fuel line (flexible hose) with end connections (having pressure exceeding 2.15 MPa)
15719: XXXX ¹	Road vehicles - Compressed natural gas (CNG) /Bio-Compressed natural gas (Bio-CNG)/ Liquefied Petroleum Gas (LPG) fuel system components – Electrical Wiring kit
15720: XXXX ¹	Road vehicles - Compressed natural gas (CNG) /Bio-Compressed natural gas (Bio-CNG) /Liquefied Petroleum Gas (LPG) fuel system component – Compartments sub- Compartments

- 15721: XXXX¹⁾ Road vehicles - Compressed natural gas (CNG) / Bio-Compressed natural gas (Bio-CNG)/ Liquefied Petroleum Gas (LPG) fuel system components – Fire retardant material for seat, upholstery, roof and side lining
- 15722: XXXX¹⁾ Road vehicles - Compressed natural gas (CNG) / Bio-Compressed natural gas (Bio-CNG) fuel system components - CNG /Bio-CNG flexible fuel line with or without end connections (having pressure not exceeding 2.15 MPa)
- 15723: XXXX¹⁾ Road vehicles - Compressed natural gas (CNG) /Bio-Compressed natural gas (Bio-CNG) /Liquefied Petroleum Gas (LPG) fuel system components – Current Limiting devices

Note — Standards Marked with superscript '1)' are under the process of Revision. The year of publication of these standards will be updated at the time of printing of this draft standard.

The composition of the Committee responsible for the formulation of this standard is given at Annex A.

For the purpose of deciding whether a particular requirement of this standard is complied with, the final value, observed or calculated, expressing the result of test or analysis, shall be rounded off in accordance with IS 2:2022 'Rules for rounding off numerical values (*Second Revision*)'. The number of significant places retained in the rounded off value should be the same as that of the specified value in this standard.

*Draft Indian Standard***ROAD VEHICLES – COMPRESSED NATURAL GAS (CNG) FUEL SYSTEM
COMPONENTS – PERFORMANCE AND GENERAL TEST METHODS****1 SCOPE**

1.1 This standard specifies performance and general test methods for CNG/Bio-CNG on board fuel system components, intended for use on motor vehicles defined in IS 14272.

1.1.1 This standard is applicable to CNG /Bio-CNG fuel system components intended to use on vehicles using compressed natural gas / Bio- compressed natural gas in accordance with IS 15320 Part 1 (mono-fuel or bi-fuel applications or dual fuel applications). This standard is not applicable to the following:

- a) Liquefied natural gas (LNG) fuel system components located upstream of, and including, the vaporizer;
- b) Fuel containers;
- c) Stationary gas engines;
- d) Container Mounting hardware;
- e) Electronic fuel management;
- f) Refuelling receptacles;
- g) CNG / Bio- CNG fuel systems components for the propulsion of marine craft; and
- h) Hydrogen Natural Gas Blend (HCNG) Fuel system components.

1.1.2 This standard is based upon a service pressure for compressed natural gas / Bio-compressed natural gas as a fuel at 20 MPa (200 Bar) settled at 15°C. Other service pressures could be accommodated by adjusting the pressure by the appropriate factor (ratio). For example, a 25 MPa (250 Bar) service pressure system will require pressures to be multiplied by 1.25. All references to pressure are to be considered gauge pressures unless otherwise specified.

2 REFERENCES

The following standards contain provisions which, through reference in this text, constitute provisions of this standard. At the time of publication the editions indicated were valid. All standards are subject to revision and parties to agreements based on this standard are encouraged to investigate the possibility of applying the most recent editions of the standards indicated below:

<i>IS No.</i>	<i>Title</i>
3400 : Part 4:2012/ ISO 188 : 2011	Methods of test for vulcanized rubber: Part 4 accelerated ageing and heat resistance (Third Revision)
3400 : Part 6:2018/ ISO 1817:2015	Methods of Test for Vulcanized Rubbers Part 6 Determination of the Effect of Liquids (Fourth Revision)
9844:1981	Methods of testing corrosion resistance of electroplated and anodized aluminium coatings by neutral salt spray test
14272:2011	Automotive Vehicles — Types — Terminology
15320 (Part 1) : 2012/ ISO 15403-1 : 2006	Natural gas - Natural gas for use as a compressed fuel for vehicles: Part 1 designation of the quality (First Revision)
15710: XXXX ²⁾	Road Vehicles — Compressed Natural Gas (CNG) / Bio-Compressed Natural Gas (Bio- CNG) Fuel System Components — General Requirements And Definitions

Note — Standards Marked with superscript ‘2)’ are under the process of Revision. The year of publication of these standards will be updated at the time of printing of this draft standard.

3 TERMS AND DEFINITIONS

For the purposes of this standard, the terms and definitions given in IS 15710 shall apply.

4 GENERAL

4.1 Unless otherwise stated, the tests shall be conducted at room temperature that is $27\pm 5^{\circ}\text{C}$.

4.2 Components shall comply with the tests specified in their relevant specifications, as well as the applicable tests specified in this standard. Because of the peculiarities of some components, the list of tests given in this standard (*see* 5 to 15) is not exhaustive. Where additional tests are required, their provisions are given in another, relevant standard.

4.3 Unless otherwise specified, all tests shall be conducted using dry air or nitrogen. Qualified personnel may also test with natural gas provided that appropriate safety measures are taken. The dew point of the test gas at the test pressure shall be at the temperature at which there is no icing, or hydrate or liquid formation.

4.4 It is recognized that new technology may not be covered in the relevant specifications of components.

5 HYDROSTATIC STRENGTH

A component shall not rupture when subjected to the following test procedure:

Plug the outlet opening of the component and have the valve seats or internal blocks assume the open position. Apply, with a test fluid, the hydrostatic pressure specified in their relevant specification to the inlet of the component for a period of at least 3 min.

The sample used in this test shall not be used for any other testing.

6 LEAKAGE

6.1 General

6.1.1 Prior to conditioning, purge the component or device with nitrogen and then seal it at 30 percent of service pressure using nitrogen, dry air or natural gas.

6.1.2 Conduct all tests while the device is continuously exposed to the specified test temperatures. The device shall either be bubble-free or have a leakage rate of less than 20 N cm³/h (The symbol 'N' indicates conversion to normal temperature and pressure condition, NTP, that is, 760 mm Hg pressure and 0°C temperature) using the following test method.

6.2 External Leakage

6.2.1 Plug each device outlet with the appropriate mating connection and apply the test pressure to the inlet.

6.2.2 Apply pressurized air, nitrogen, or natural gas to the test device.

6.2.3 At all test temperatures, immerse the components in a suitable test medium for 2 min or use a helium vacuum test (global accumulation method) or other equivalent method.

6.2.4 If there are no bubbles for the specified time period, the sample passes the test. If bubbles are detected measure the leak rate by an appropriate method.

6.3 Internal Leakage

6.3.1 The internal leakage test is applicable only to devices having a closed position. The aim of this test is to check the pressure tightness of the closed system.

6.3.2 Connect the inlet or outlet (as applicable) of the device, with the appropriate mating connection, while leaving the opposite connection or connections open.

6.4 Test Conditions

6.4.1 General

The leakage test conditions depend on whether the component is exposed to cylinder pressure or located downstream of the first stage of pressure reduction.

6.4.2 Devices Exposed to Cylinder Pressure

6.4.2.1 The device shall be conditioned at least 8h at a low temperature of -20°C , and pressurized at 75 percent and 2.5 percent of service pressure.

6.4.2.2 The device shall be conditioned at least 8h at a room temperature of $27 \pm 5^{\circ}\text{C}$ and pressurized at 2.5 percent and 150 percent of service pressure.

6.4.2.3 The device shall be conditioned at least 8h at a high temperature of 85°C or 120°C and pressurized at 5 percent and 150 percent of service pressure.]

6.4.3 *Devices Downstream of the First Stage of Pressure Reduction*

6.4.3.1 The device shall be conditioned at a low temperature of -20°C , and pressurized at 75 percent and 2.5 percent of working pressure.

6.4.3.2 The device shall be conditioned at a room temperature of $27 \pm 5^{\circ}\text{C}$ and pressurized at 2.5 percent and 150 percent of working pressure.

6.4.3.3 The device shall be conditioned at a high temperature of 85°C or 120°C and pressurized at 5 percent and 150 percent of working pressure.

7 EXCESS TORQUE RESISTANCE

A component designed to be connected directly to threaded fittings shall be capable of withstanding, without deformation, breakage or leakage, a torque effort of 150 percent of the rated installation value, according to the following test procedure:

- a) Test an unused component, applying the torque adjacent to the fitting.
- b) For a component having a threaded connection or threaded connections, apply the turning effort for 15 min, release it then remove the component and examine it for deformation and breakage.
- c) Subject the component to the leakage test specified in 6.

8 BENDING MOMENT

A component shall be capable of operation without cracking, breaking, or leaking when tested according to the following procedure:

a) Assemble the connections of the component, leak-tight to an appropriate mating connection or connections, representative of design intent. After assembly, the length of the inlet tubing shall be greater than 300 mm (*see* Fig. 1).

b) The outlet connection shall be rigidly supported, 25 mm from the component outlet, except in the following cases:

- i) If the component has an integral mounting means independent of the inlet and outlet connections, the component shall be mounted using the integral mounting means specified by the manufacturers;
- ii) If the component is intended to be mounted by either the integral mounting means or the component outlet, the mounting means that produces the most severe test condition shall be used.

c) Check this assembly for leaks prior to subjecting it to (d).

d) With the component in the closed position, pressurize the system to 5 kPa (50 mbar) and apply a force according to Table 1, 300 mm from the inlet, maintaining it for 15 min. Without removing the force, check the component for leakage, in accordance with the test method given in 6, at room temperature.

NOTE — Depending on how this test is performed raising the load to compensate buoyancy could be necessary.

e) Conduct procedure (d) four times, rotating the component 90° around the horizontal axis between each test. Between tests, open and close (if applicable) the component three times with the bending moment removed.

f) At the completion of the above tests, remove the component and examine it for deformation; then subject it to the leakage test according to 6.

Table 1 Bending Moment Test Force

SI No. (1)	Outside Diameter of Tubing mm (2)	Force N (3)
i)	6	3.4
ii)	8	9.0
iii)	≥ 12	17.0

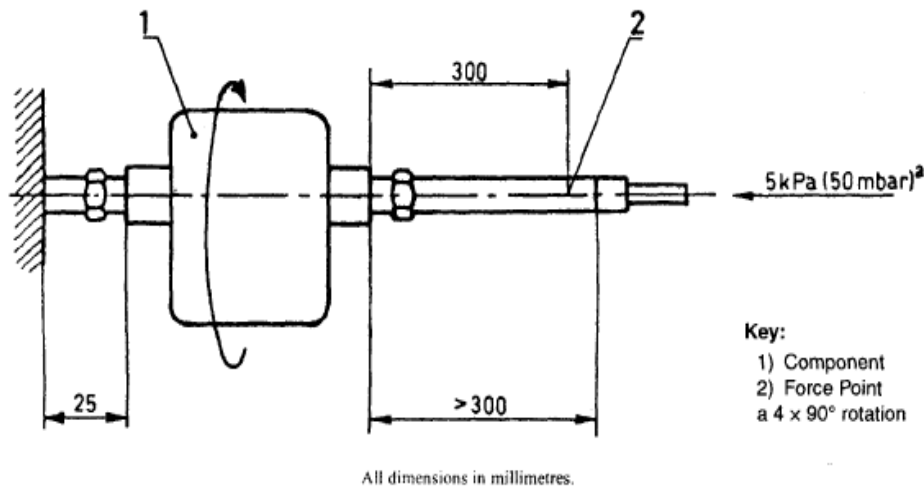

Fig. 1 Bending Moment

9 CONTINUED OPERATION

9.1 General

For the details of test methods for particular components, see their relevant standard. The method specified in this clause is general in nature and also applies to miscellaneous components.

9.2 Test Method

9.2.1 Test Procedure

Connect the component securely by a suitable fitting to a pressurized source of dry air, nitrogen or natural gas and subject it to the number of cycles specified in their relevant specification. A cycle shall consist of one opening and (if applicable) one closing of the component within a period of not less than 10 ± 2 s.

During the off-cycle, the downstream pressure of the test fixture shall be lowered to a maximum of 50 percent of the test pressure.

In the case of components downstream of the first stage of pressure reduction, the test pressure shall be based on 100 percent of the working pressure.

Unless otherwise specified, the conditions of **9.2.2** and **9.2.3** apply.

9.2.2 Room Temperature Cycling

Operate the component through 96 percent of the total cycles at room temperature and at service pressure, according to **6**. This test may be interrupted, if desired, at 20 percent intervals for leakage testing.

9.2.3 High Temperature Cycling

Operate the component through 2 percent of the total cycles at the appropriate maximum temperature specified in **4.4** of IS 15710, at service pressure. The component shall comply with **6** at the appropriate maximum temperature at the completion of the high temperature cycles.

9.2.4 Low Temperature Cycling

Operate the component through 2 percent of the total cycles at the appropriate minimum temperature specified in **4.4** of IS 15710 at 50 percent service pressure. The component shall comply with **6** at the appropriate minimum temperature at the completion of the low temperature cycles.

10 CORROSION RESISTANCE

10.1 All components shall perform safely and in compliance with **6** following exposure to salt spray according to the following test method.

10.2 With the component supported in its normal installed position, expose it for 96 h to a salt spray (fog) test as specified in IS 9844.

10.3 Maintain the temperature within the fog chamber at between 33°C and 36°C.

10.4 The saline solution shall consist of 5 percent sodium chloride and 95 percent distilled water, by weight.

10.5 Immediately following the corrosion test, rinse the sample and gently clean it of salt deposits; then subject it to the tests according to **6**.

11 OXYGEN AGEING

All synthetic or non-metallic parts of components that provide a fuel-containing seal for which a satisfactory declaration of properties is not submitted by the applicant shall not crack or show visible evidence of deterioration after oxygen ageing when tested according to the following procedure.

Subject representative samples to 96 h of exposure to oxygen at a temperature of 70°C, at 2 MPa (20 bar) in accordance with IS 3400 (Part 4).

12 ELECTRICAL OVERVOLTAGE

All electrical components or devices containing electrical subcomponents shall withstand the application of 1.5 times the rated voltage \pm 5 percent for periods of 3 min without failure.

13 NON-METALLIC SYNTHETIC IMMERSION

13.1 Non-metallic synthetic material used in a component shall be subjected by the test agency to the tests described in **13.2** and **13.3**, except where the applicant submits declarations of results of tests carried out on the material provided by the manufacturer.

13.2 A part made of non-metallic synthetic material in contact with natural gas shall not show excessive change in volume or weight when tested according to the following procedure:

- a) Prepare, measure and weigh a representative sample or samples of each non-metallic synthetic material used in a component, then Immerse the sample or samples at room temperature in natural gas at a pressure of 20 MPa (200 bar) for a minimum of 70 h.
- b) Following this period of immersion, rapidly reduce the test pressure to atmospheric pressure without causing shredding or disintegration. No tested sample shall exhibit swelling greater than 25 percent or shrinkage greater than 1 percent. The weight change shall not exceed 10 percent.

13.3 Non-metallic synthetic material used in a component that could be exposed to ester-based or alpha olefin-based synthetic compressor oils, including non-synthetic compressor oils, shall not show excessive change in volume or weight when tested in accordance with IS 3400 (Part 6) or the following procedure:

- a) Prepare, measure and weigh a representative sample or samples of each non-metallic synthetic material used in a component, then immerse the sample or samples at room temperature in holders each containing one of the test fluids for a minimum of 70 h.

- b) Following this period of immersion, remove and measure the test samples. No sample shall exhibit swelling greater than 25 percent or shrinkage greater than 1 percent. The weight change shall not exceed 10 percent.

14 VIBRATION RESISTANCE

All components with moving parts shall remain undamaged, and shall continue to operate and meet the requirements of their leakage tests after 6 h of vibration carried out according to the following test procedure:

- a) Secure the component in a test apparatus and vibrate for 2h at 17 Hz with an amplitude of 1.5 mm in each of three orientation axes.
- b) On completion of this total of 6 h vibration, the component shall comply with the requirements of 6.

15 BRASS MATERIAL COMPATIBILITY

All fuel-containing brass components or subcomponents for which a satisfactory declaration of properties is not submitted by the applicant shall be tested according to the following procedure (component manufacturers able to provide documentation attesting to the field worthiness of their products are exempted from this requirement).

- a) Subject each test sample to the physical stresses normally imposed on, or within a part as a result of assembly with other components. Apply these stresses to the sample prior to the test and maintain them during it. Samples with thread, intended to be used for installing the product in the field, shall have the threads engaged and tightened to the torque specified in the instruction manual of the sample. Poly-tetrafluoro ethylene (PTFE) tape or pipe compounds shall not be used on the threads.
- b) Degrease three samples and continuously expose them for 10d at a set position to a moist, ammonia-air mixture maintained in a glass chamber of approximately 30 litre capacity and with a glass cover. Maintain approximately 600 cm³ of aqueous ammonia, with a relative density (specific gravity) of 0.94 at the bottom of the glass chamber, below the samples. Position the samples 40 mm above the aqueous ammonia solution, supported by an inert tray. Maintain the moist ammonia-air mixture in the chamber at atmospheric pressure and at a temperature of 34±2°C.

After being subjected to the conditions of this procedure, samples shall show no evidence of cracking when examined at 25 x magnification.

ANNEX A
(Foreword)

COMMITTEE COMPOSITION

Automotive Vehicles Running on Non-conventional Energy Sources Sectional Committee, TED 26

Will be Added Later.