

BUREAU OF INDIAN STANDARDS

DRAFT FOR COMMENTS ONLY

Not to be reproduced without permission of BIS or use as Standard

Doc No.: PGD 40 (23475)

September 2023

भारतीय मानक मसौदा
रबर कन्वेयर और एलिवेटर टेक्सटाइल बेल्टिंग हेतु विशिष्टि
भाग 2 ऊष्मा प्रतिरोधी बेल्टिंग
(IS 1891-2 का तीसरा पुनरीक्षण)

Draft Indian Standard
Specification for Rubber Conveyor and Elevator Textile Belting
Part 2 Heat Resistant Belting
(Third Revision of IS 1891-2)

ICS 53.040.10

Conveyor Belts Sectional Committee, PGD 40

Last Date for Comments: 31-10-2023

FOREWORD

(formal clause to be added later on)

This standard was first published in 1972 and revised in 1978 in line with the manufacturing practices and to incorporate SI units. Second revision has been issued to raise the heat resistance to 160 C. Accordingly, all the test requirements have been modified. Ageing period has been increased from 3 days to 168 h. Hardness test has been added.

This third revision has been brought out to take care the experience gained since the last publication and to bring it in line with the current manufacturing practices vis-à-vis new technological advancements. SI system of units have been followed in the standard.

Other part in this series are:

- Part 1 General purpose belting
- Part 3 Oil-resistant belting
- Part 4 Hygienic belting
- Part 5 Fire resistant belting for surface application

The major changes made in this standard as compared to the second revision are:

- a) All the amendments issued to the previous version of the standard have been amalgamate and the text of the standard has been suitably modified to make it more user friendly;
- b) Introduction to various types of heat resistant belting used in food industry along with relevant tests applicable to them have been included;
- c) Some new tests like fire resistance, electrical surface resistance test (antistatic test), volume swelling, heat resistance, non-stick test and tear resistance test have been added; and
- d) Method of testing tear strength test has also been given in the standard.

For the purpose of deciding whether a particular requirement of this standard is complied with the final value, observed or calculated, expressing the result of a test or analysis shall be rounded off in accordance with IS 2 : 2022 'Rules for rounding off numerical values (*second revision*).'

Draft Indian Standard
Specification for Rubber Conveyor and Elevator Textile Belting
Part 2 Heat Resistant Belting
(*Third Revision of IS 1891-2*)

1 SCOPE

Covers the requirements of rubber conveyor and elevator textile belting for use on flat or troughed idlers for conveying hot materials which are classified as follows:

	<i>Resistance to Temperature, °C (Max)</i>	
	<i>Lump Materials</i>	<i>Powdered Materials</i>
Grade T-1	125	100
Grade T-1	150	125

2 REFERENCES

The following standards contain provisions, which through reference in this text, constitute provisions of this standard. At the time of publication the editions indicated were valid. All standards are subject to revision and encouraged to investigate the possibility of applying the most recent editions of the standards.

<i>IS No.</i>	<i>Title</i>
IS 1891 (Part 1): 1994	Conveyor and elevator textile belting — Specification: Part 1 General purpose belting (<i>fourth revision</i>)
IS 3400 (Part 2) : 1980	Methods of test for vulcanized rubbers: Part 2 Hardness (<i>first revision</i>)
IS 3400 (Part 3) : 1987	Methods of test for vulcanized rubbers: Part 3 Abrasion resistance using a rotating cylindrical drum device (<i>first revision</i>)
IS 3400 (Part 4) : 1978	Methods of test for vulcanized rubbers: Part 4 Accelerated ageing (<i>first revision</i>)

3 TERMINOLOGY, DIMENSIONS, TOLERANCES, FABRIC, CONSTRUCTION AND FULL THICKNESS BREAKING STRENGTH

As prescribed in IS : 1891 (Part 1).

4 TEST REQUIREMENTS OF FINISHED BELTING

4.1 Breaking strength, elongation at break and hardness of rubber cover when tested as described in Appendix C of IS 1891 (Part 1) shall be as follows:

	Grade	T-1	Grade	T-2
Breaking strength, MPa, Min	12.5			12.5
Elongation at break percent, Min	350			350
Hardness (IRHD)	60 ± 5		60	± 5

4.2 Further based upon application of usage of hygienic belting, following hygiene belts are covered in the standard:

- a) Agriculture & harvesting (grains) belts — Characteristics — Non-toxic, antistatic, fire resistant;
- b) Oil mill conveyor belts — Characteristics — Non-toxic, oil resistant, fire resistant;
- c) Tea conveyor belts — Characteristics — Non-toxic;
- d) Sugar conveyor belts — Characteristics — Non-toxic, abrasion resistant, antistatic, fire resistant;
- e) Chocolate/candy conveyor belts — Characteristics — Non-toxic, non-stick, resistant to vegetable oils;
- f) Bakery conveyor belts — Characteristics — Non-toxic, resistant to high temperature, Resistant to vegetable oils;
- g) Fruits & vegetables conveyor belts — Characteristics — Non-toxic, tear resistance;
- h) Meat & poultry belts — Characteristics — Non-toxic, resistant to animal oils/fats, resistant to microbial formulation; and
- j) Fish & seafood processing belts — Characteristics — Non-toxic, resistant to temperature, tear resistance; resistance to animal fats.

5 FABRIC

Fabric shall be as per IS 1891 (Part 1). In case the belts are manufactured from cotton duck, they shall conform to Type 28 or 32 of IS 5996.

6 RUBBER COVER — HYGIENIC REQUIREMENT

All the compounding ingredients used in the rubber compound from which the rubber covers are made should be free from harmful ingredients liable to extraction by contact with the foodstuffs and other materials being handled or which may cause the development of undesirable odour, taste or discoloration. The compounding ingredients recommended for this purpose are as given in Annex A.

7 CONSTRUCTION

Construction shall be as per prescribed in IS 1891 (Part 1). Hygienic beltings shall be of full width ply construction only.

The surface of the cover on the carrying side of the belt shall be considerably smooth so that particles of the material conveyed will not stick to the belt and cause contamination.

8 TEST REQUIREMENTS OF FINISHED BELTING

The tests specified in clause 8.1 to 8.10 shall be applicable depending on the type of hygiene belts as given in Table 1.

8.1 Tensile Strength and Elongation at Break of Rubber Cover

When tested as per in Annex B of IS 1891 (Part 1), the tensile strength and elongation at break of the rubber cover shall be as follows:

Tensile strength: 10 MN/m² Min; and

Elongation at break: 350 percent, Min.

8.2 Adhesion

The adhesion between the individual plies and between the cover and the plies shall be such that when tested as per Annex G of IS 1891 (Part 1), the force required to cause separation of the plies shall meet the requirements given in Table 2.

Table 2 Loads for Adhesion Testing

(Clause 8.2)

Sl. No.	Test	Load, Min kN/m width
(1)	(2)	(3)
i)	Adhesion between individual plies	2.45
ii)	Adhesion between cover and plies:	
	a) Covers up to and including 1.0 mm thick	(No test)
	b) Covers over 1.0 mm thick	2.35

NOTE — No individual value obtained at the time of measurement should be below the values specified above by more than 0.8 kN/m.

8.3 Ageing Test

After ageing for 72h at $70 \pm 1^\circ\text{C}$ as per IS 3400 (Part 4), the tensile strength and elongation at break of the rubber used for the cover shall not vary by more than + 10 – 25 percent and + 10 – 45 percent respectively from the corresponding values obtained before ageing.

8.4 Troughability

Troughability shall be as per IS 1891 (Part 1).

8.5 Heat Resistance

Rubber cover after exposure to a temperature of $100 \pm 2^\circ \text{C}$ for 168h, the test being carried out as described in IS 3400 (Part 4), the breaking strength, elongation at break of the rubber covers shall not vary from the original unaged values by more than 35 percent and 50 percent respectively.

8.6 Non-stick Test

The compound to be carried on belt shall not stick on the top surface of the belt. The compliance shall be checked by visual inspection.

8.7 Volume swelling

The cover of the betting when tested in accordance with IS 3400 (Part 6) shall comply with the following:

Test temperature: $27 \pm 1^\circ \text{C}$;

Test Liquid: Animal or Vegetable oil (as per declaration of actual usage of belt, by supplier);

Test Duration: $70 \pm 2 \text{ h}$; and

Change in volume percentage: 75 percent max.

8.8 Electrical Surface Resistance Test (Antistatic Test)

The belt shall be tested for antistatic properties. Belt when tested in accordance with Annex C, the electrical resistance of each of the averages shall not exceed $300 \text{ M}\Omega$.

8.9 Fire Resistance

8.9.1 Drum Friction Test

The belt when tested in accordance with Annex A of IS 1891 (Part 5) shall show no sign of flame, spark or glow. The drum temperature shall not exceed 325°C and belting shall part within the 3h test period.

The drum friction test shall be carried for the purpose of approval of new belt construction. Frequency of this test for supplies of an approved belt construction may be as agreed to between the manufacturer and the purchaser and shall be considered as type test.

8.9.2 Flame Test

For each set of four samples, when tested in accordance with Annex B of IS 1891 (Part 5), the average duration of the flame shall not exceed 40s and the average duration of glow shall not exceed 120s.

8.10 Tear Strength

Belt shall be tested for Tear propagation resistance test as described in Annex B. The Tear propagation resistance shall be as agreed between manufacturer and purchaser.

Table 1 Tests Applicable on Various Types of Belts

(Clause 8)

SI No.	Type of Belt	Tensile Strength and Elongation at Break of Rubber Cover	Adhesion	Ageing	Troughability	Heat resistance	Resistance to Abrasion	Non-stick test	Volume swelling	Electrical surface resistance test	Fire resistance	Tear resistance
(1)	(2)	(3)	(4)	(5)	(6)	(7)	(8)	(9)	(10)	(11)	(12)	(13)
(i)	Agriculture & Harvesting (Grains) belts	X	X	X	X	-	X	-	X	X	X	-
(ii)	Oil mill conveyor belts	X	X	X	X	-	-	-		X	X	-
(iii)	Tea conveyor belts	X	X	X	X	-	-	-	X	-	-	-
(iv)	Sugar conveyor belts	X	X	X	X	-	X	-	-	X	X	-
(v)	Chocolate/candy conveyor belts	X	X	X	X	X	-	X	-	-	-	-
(vi)	Bakery conveyor belts	X	X	X	X	X	-	X	-	-	-	-
(vii)	Fruits and vegetables conveyor belts	X	X	X	X	-	X	-		-	-	X

(viii)	Meat & Poultry conveying belts	X	X	X	X	-	-	X	X	-	-	X
(ix)	Fish and sea food processing belts	X	X	X	X	-	X	X	X	-	-	X

X = Applicable, and – = Not applicable

9 PACKING

The belting shall be packed as mutually agreed to between the purchaser and the manufacturer.

10 MARKING

The belting shall be marked as follows at the intervals of 5 m to 10 m on the carrying surface:

- a) The symbol 'A' to denote hygienic quality of the belting;
- b) Type of usage (Bakery conveyor belt/sugar conveyor belt etc.);
- c) The last two digits of the year of the manufacture;
- d) Letters or trade-mark identifying the manufacturer; and
- e) The number of this standard.

10.1 BIS Certification Marking

The products(s) conforming to the requirements of this standard may be certified as per the conformity assessment schemes under the provision of the *Bureau of Indian Standard Act, 2016* and the Rules and Regulations framed thereunder, and the product may be marked with the standard mark.

11 SAMPLING AND INFORMATION TO BE SUPPLIED BY THE PURCHASER WITH ENQUIRY OR ORDER

Shall be as per in IS 1891 (Part 1).

12 OTHER REQUIREMENTS

Any other requirement not specifically mentioned in this standard shall be as laid down in IS 1891 (Part 1).

ANNEX A
(Clause 6)
RECOMMENDED COMPOUNDING INGREDIENTS

A-1 GENERAL

In giving the following data, it is not intended to imply that the use of alternative materials may not give belts of a suitable quality. The recommendations are, in every case, intended mainly to indicate types of materials which have been found, by practical experience, to be suitable for producing belts to be used for conveying food stuffs.

A-2 COMPOUNDING

A-2.1 The belts may be made from natural rubber, or some suitable synthetic non-toxic elastomer or a blend of the two together with the necessary compounding ingredients.

A-2.2 All the compounding ingredients used in the rubber shall be free from harmful materials liable to extraction by contact with foodstuffs or which may cause the development of undesirable odour, taste or discolouration.

NOTE — In the case of natural rubber belts, light coloured crape of natural rubber that has been rendered suitable for extrusion (superior processing rubber), or air-dried plantation rubber that is free from p-nitrophenol (so called air-dried sheets), and in the case of synthetic rubber belts, cis-1, 4-polyisoprene, polybutadiene, styrene-butadiene copolymers, nitrile-butadiene copolymers or chloroprene rubber (polychloroprene), or a blend of any of these, may be used as raw material. Divinyl benzene may be used as the third polymerization component.

A-3 ACCELERATORS

Recommended accelerators of the tasteless type to suit the requirements specified in **A-2** are thiuram disulphides or monosulphides, dithiocarbamates and suitable polyamines.

A-4 ANTIOXIDANTS

Where it is considered that an antioxidant be employed, the following materials are recommended.

- a) Condensation products of acetone and aniline
- b) Di-βnaphthyl- p phenylenediamine (symmetric)

A-5 FILLERS

The following fillers are recommended.

- a) China Clay — China clay should be as per IS 505;
- b) Barytes — Barytes should be as per IS 1683;
- c) Blanc Fixe;
- d) Kieselguhr;
- e) Silica;
- f) Whiting — Whiting shall be as per IS 1685; and

- g) Carbon black.

A-6 SOFTENERS

The following softeners are recommended:

- a) Stearic Acid — Stearic acid shall be as per IS 1675;
- b) Petroleum Jelly; and
- c) Light Coloured Mineral Oil — An example of light coloured mineral oil is transformer oil which shall be as per IS 335.

ANNEX B
(Clause 8.10)

METHOD OF DETERMINING TEAR PROPAGATION RESISTANCE

B-1 PRINCIPLE

The test consists in measuring, by means of tensile testing at a given speed, the force necessary to propagate an initial tear made in a test piece.

B-2 APPARATUS

The apparatus consists of a dynamometric tensile testing machine with the following essential characteristics:

- a) the machine shall be so chosen that the forces to be measured come within the upper 90 percent range of its full rated capacity;
- b) the speed of separation of the jaws shall be capable of being adjusted to (50 ± 10) mm/min; and
- c) the free distance between the jaws shall be capable of being adjusted to at least 300 mm.

The machine shall be provided with a device for the graphical recording of the force necessary to continue tearing the test piece.

B-3 TEST PIECES

B-3.1 Method of Sampling

Test pieces shall be taken from the sample in the longitudinal direction of the belt and at a minimum distance of 50 mm from the edges of the belt.

B-3.2 Shape and Dimensions

Shape and dimension of test pieces shall be as follows:

- a) Shape: rectangular;
- b) Length: 300 mm.;
- c) Width: 100 ± 1 mm; and
- d) Thickness: Full belt thickness or without covers.

If it is found that weft threads are pulled out of the test piece instead of breaking, the width of the test piece should be increased to 300 mm.

B-3.3 Number

Two test pieces shall be used: one in sense 'A' and the other in sense 'B' (*see* Fig 4).

B-3.4 Preparation

Where the test is to be conducted without covers, the covers of the test pieces shall be removed by stripping or by buffing.

If there is a breaker ply, strip the corresponding covers without cutting the breaker ply over a width of 20 mm only that is, 10 mm on each side of the longitudinal axis of the test piece with the exception of the zone held in the jaws of the machine (*see* Fig 1).

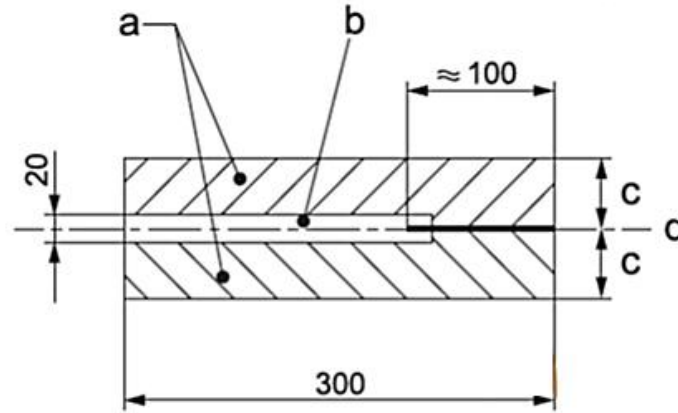

- Key
- a = with covers
 - b = covers removed
 - c = 50 or 150
 - d = cut line

Dimensions in millimetres

FIG. 1 TEST PIECES WITH BREAKER

Cut the test pieces from the middle of one of their ends over a length of about 100 mm parallel to the length (*see* Fig. 2).

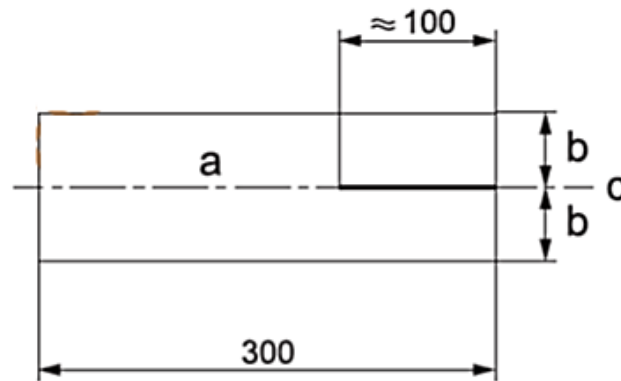

- Key
- a = without covers
 - b = 50 or 150
 - c = cut line

All Dimensions are in millimetres

FIG. 2 TEST PIECES WITHOUT BREAKER

If necessary, the width of the test piece (cut-edge) may be adjusted to the gripping width of the jaws by tapering the edges symmetrically on a length at most the same as that of the cut (*see* Fig 3), with the width at the end of the cut part as wide as the width of the jaws permits.

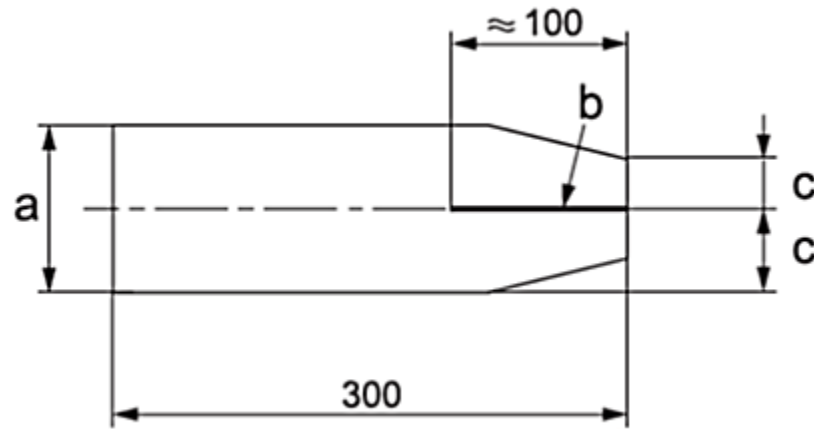

Key
a 300 or 100
b cut line

All Dimensions are in millimetres

FIG. 3 TAPERED TEST PIECE

B-4 METHOD OF TEST

B-4.1 Conditioning of Test Pieces

The tests shall start not less than 24h after manufacturing. This time includes 8h for conditioning. The conditioning atmosphere shall be one or another of the following:

- temperature 20 ± 2 °C with 65 ± 5 percent relative humidity;
- temperature 23 ± 2 °C and 50 ± 5 percent relative humidity; and
- temperature 27 ± 2 °C and 65 ± 5 percent relative humidity.

The tests shall be conducted in the same atmosphere as used for conditioning.

The atmosphere at which the test pieces are conditioned and tested shall be given in the test report.

In the event of any dispute, regarding the period of conditioning, shall be 72h.

B-4.2 Test Conditions

The test conditions with regard to temperature and humidity shall be those adopted in B-4.1.

B-4.3 Procedure

Mount the two cut ends of the test piece in the jaws of the tensile testing machine either in sense A or in sense B (see Fig. 4), so that the inner edges of the cut are situated at the centre of each jaw.

Fix the speed of separation of the jaws at (50 ± 10) mm/min and continue testing until the tear has extended for at least 100 mm.

Record the tearing forces over the length of the tear by means of a graphical device.

B-4.4 Expression of Results

Examination and analysis of the multi-peak tear resistance test traces shall be in accordance with ISO 6133. The median peak force is defined as the mean tear resistance.

Indicate the resistance of each test piece separately and then indicate the mean value of the resistance of the two test pieces.

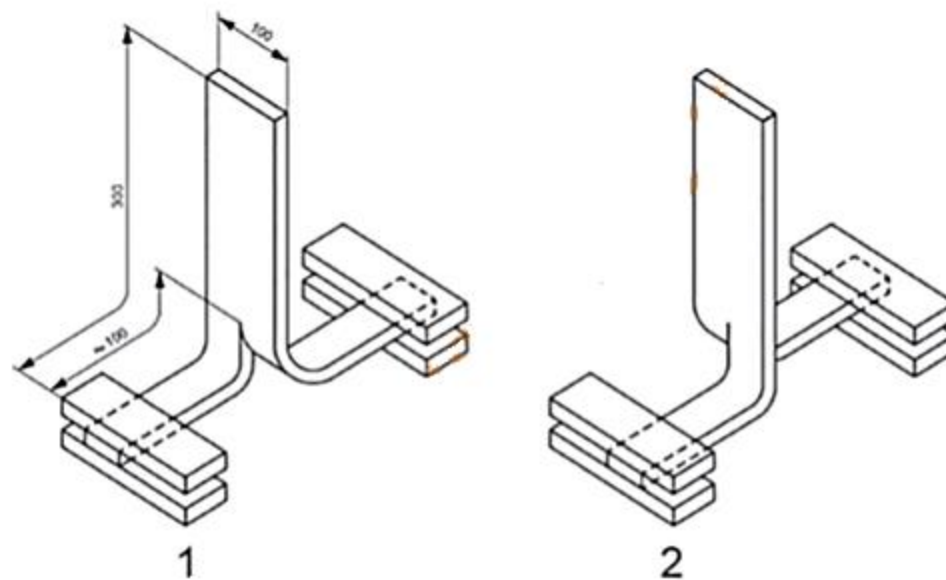

Key

- 1.sense A
- 2.sense B

All Dimensions are in millimetres

FIG. 4 MOUNTING OF TWO CUT ENDS OF TEST PIECE

B-4.5 Test Report

The test report shall refer to this standard and shall include the following:

- a) identification of the belt tested;
- b) the temperature and relative humidity adopted for the conditioning of the test pieces and the tests;
- c) the results expressed in accordance with B-4.4;
- d) whether the test was conducted with or without covers; and

- e) an account of any test or operating conditions not specified in this document.