

BUREAU OF INDIAN STANDARDS
DRAFT FOR COMMENTS ONLY

Not to be reproduced without permission of BIS or used as Standard

Doc: PGD 37 (27470) WC
February 2025

भारतीय मानक मसौदा

फलैंज सहित षट्कोणीय ढिबरियाँ, शैली 2 – विशिष्टि
(IS 15581 का दूसरा पुनरीक्षण)

Draft Indian Standard

Hexagon Nuts with Flange, Style 2 — Specification
(*Second Revision of IS 15581*)

ICS 21.060.20

General Engineering and Fasteners Standards Sectional Committee, PGD 37	Last date for receipt of comment is 02 March 2025
--	---

FOREWARD

(Formal Clause will be added later on)

This Indian Standard was first published in 1972 and was subsequently revised in 2018. The first revision of this standard was identical with ISO 4161 : 2012. In this second revision, the scope of the standard has been enlarged to include nuts with fine pitch threads also.

In the formulation of this standard, considerable assistance has been derived from the following International Standards:

ISO 4161 : 2012	Hexagon nuts with flange, style 2 — Coarse thread
ISO 10663 : 2012	Hexagon nuts with flange, style 2 — Fine pitch thread

For the purpose of deciding whether a particular requirement of this standard is complied with the final value, observed or calculated, expressing the result of a test or analysis shall be rounded off in accordance with IS 2 : 2022 ‘Rules for rounding off numerical values (*second revision*).’ The number of significant places retained in the rounded off value should be the same as that of the specified value in this standard.

Draft Indian Standard

HEXAGON NUTS WITH FLANGE, STYLE 2 — SPECIFICATION
(*Second Revision of IS 15581*)

1 SCOPE

This standard covers the requirements of hexagon nuts with flange (style 2), with metric threads.

NOTE — The various styles of hexagon nuts based on thickness are defined in IS 1367 (Part 6).

2 REFERENCES

The standards listed in Annex A contain provisions which, through reference in this text, constitute provisions of this standard. At the time of publication, the editions indicated were valid. All standards are subject to revision, and parties to agreements based on this standard are encouraged to investigate the possibility of applying the most recent edition of these standards.

3 SYMBOLS

For the purpose of this standard, the symbols given in IS 8536 shall apply.

4 DIMENSIONS

The dimensions of hexagon nuts with flange, style 2 shall be as given in Fig. 1, Table 1 and Table 2.

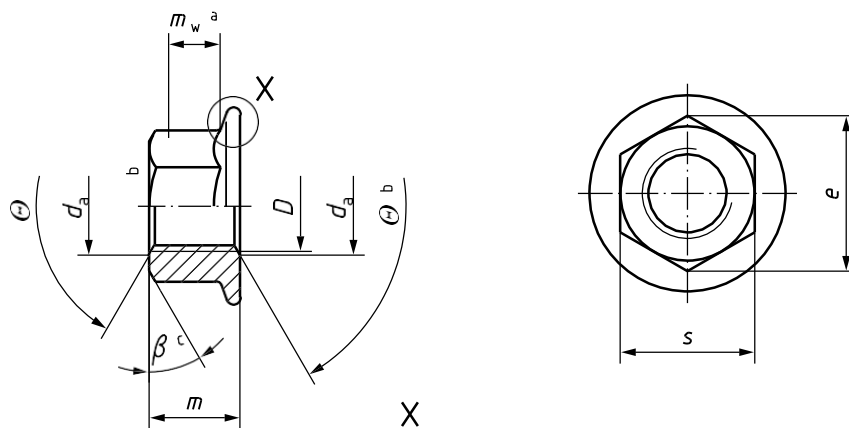

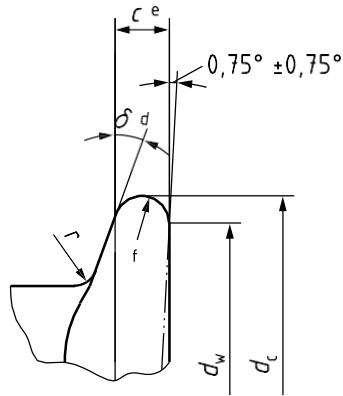

- a) m_w is the wrenching height
- b) $\theta = 90^\circ$ to 120° .
- c) $\beta = 15^\circ$ to 30° .
- d) $\delta = 15^\circ$ to 25° .
- e) c is measured at $d_{w,\min}$
- f) Contour of the edge is at the discretion of the manufacturer.

FIG. 1 DIMENSIONS OF HEXAGON NUTS WITH FLANGE, STYLE 2

Table 1 Dimensions of Hexagon Nuts with Flange, Style 2 (Coarse Thread)
(Clause 4)

All dimensions in millimetres

SI No.	Thread <i>D</i>	M5	M6	M8	M10	M12	(M14) ¹⁾	M16	M20	
(1)	(2)	(3)	(4)	(5)	(6)	(7)	(8)	(9)	(10)	
i)	$P^2)$	0.8	1	1.25	1.5	1.75	2	2	2.5	
ii)	$c^3), Min$	1.0	1.1	1.2	1.5	1.8	2.1	2.4	3.0	
iii)	d_a	<i>Max</i>	5.75	6.75	8.75	10.80	13.00	15.10	17.30	21.60
		<i>Min</i>	5.00	6.00	8.00	10.00	12.00	14.00	16.00	20.00
iv)	d_c, Max	11.8	14.2	17.9	21.8	26.0	29.9	34.5	42.8	
v)	d_w, Min	9.8	12.2	15.8	19.6	23.8	27.6	31.9	39.9	
vi)	$e^3), Min$	8.79	11.05	14.38	16.64	20.03	23.36	26.75	32.95	
vii)	m	<i>Max</i>	5.00	6.00	8.00	10.00	12.00	14.00	16.00	20.00
		<i>Min</i>	4.70	5.70	7.64	9.64	11.57	13.00	15.30	18.70
viii)	$m_w^3), Min$	2.5	3.1	4.6	5.6	6.8	7.7	8.9	10.7	
ix)	s	<i>Max</i>	8.00	10.00	13.00	15.00	18.00	21.00	24.00	30.00
		<i>Min</i>	7.78	9.78	12.73	14.73	17.73	20.67	23.67	29.16
x)	$r^4), Max$	0.3	0.4	0.5	0.6	0.7	0.9	1.0	1.2	

¹⁾The size in parentheses should be avoided if possible.
²⁾ P is the pitch of the thread.
³⁾If the product passes the gauging given in Annex B, the requirements for dimensions e , c and m_w are satisfied.
⁴⁾Radius, r , applies both at the corners and the flats of the hexagon.

Table 2 Dimensions of Hexagon Nuts with Flange, Style 2 (Fine Pitch Thread)
(Clause 4)

All dimensions in millimetres

SI No	Thread $D \times P^{1)}$	M8×1	M10×1.25 (M10×1) ²⁾	M12×1.25 (M12×1.5) ²⁾	(M14×1.5) ²⁾	M16×1.5	M20×1.5	
(1)	(2)	(3)	(4)	(5)	(6)	(7)	(8)	
i)	$c^{3)}$, <i>Min</i>	1.2	1.5	1.8	2.1	2.4	3.0	
ii)	d_a	<i>Min</i>	8.75	10.80	13.00	15.10	17.30	21.60
		<i>Max</i>	8.00	10.00	12.00	14.00	16.00	20.00
iii)	d_c , <i>Max</i>	17.9	21.8	26.0	29.9	34.5	42.8	
iv)	d_w , <i>Min</i>	15.8	19.6	23.8	27.6	31.9	39.9	
v)	$e^{3)}$, <i>Min</i>	14.38	16.64	20.03	23.36	26.75	32.95	
vi)	m	<i>Max</i>	8.00	10.00	12.00	14.00	16.00	20.00
		<i>Min</i>	7.64	9.64	11.57	13.30	15.30	18.70
vii)	$m_w^{3)}$, <i>Min</i>	4.6	5.6	6.8	7.7	8.9	10.7	
viii)	s	<i>Max</i>	13.00	15.00	18.00	21.00	24.00	30.00
		<i>Min</i>	12.73	14.73	17.73	20.67	23.67	29.16
ix)	$r^{4)}$, <i>Max</i>	0.5	0.6	0.7	0.9	1.0	1.2	

¹⁾ P is the pitch of the thread.

²⁾The size in parentheses should be avoided if possible.

³⁾If the product passes the gauging given in Annex B, the requirements for dimensions e , c and m_w are satisfied.

⁴⁾Radius, r , applies both at the corners and the flats of the hexagon.

5 MECHANICAL AND PERFORMANFCE REQUIREMENTS

The various requirements of hexagon nuts with flange, style 2 shall be as given in Table 3.

Table 3 Requirements
(Clause 5)

SI No.	Material		Steel	Stainless Steel
(1)	(2)	(3)	(4)	(5)
i)	General requirements	As specified in	IS 1367 (Part 1)	
ii)	Thread	Tolerance class	6H	
		As specified in	IS 4218 (Part 2), IS 14962 (Part 2)	
iii)	Mechanical property	Property class	8, 9, 10, 12 for coarse thread and 8, 10, 12 for fine pitch thread	A2-70
		As specified in	IS 1367 (Part 6)	IS 1367 (Part 14/Sec 2)
iv)	Tolerance	Product grade	A for $D \leq M16$ B for $D > M16$	
		As specified in	IS 1367 (Part 2)	
v)	Finish — Coating	As processed		As processed
		Electroplated coatings as specified in IS 1367 (Part 11)		
		Non-electrolytically applied zinc flake coatings as specified in IS/ISO 10683		
		Hot dip galvanized coatings as specified IS 1367 (Part 13)		
		Additional requirements or other finishes or coatings shall be agreed between the supplier and the purchaser		
vi)	Surface integrity	Limits for surface discontinuities as specified in IS 1367 (Part 10)		
vii)	Acceptability	Acceptance inspection as specified in IS 1367 (Part 17)		

6 DESIGNATION

The designation of nuts shall be in accordance with IS 1367 (Part 16).

7 MARKING

7.1 Labelling on Package

The following shall be marked on the package:

- a) The thread size *D*,
- b) For steel nuts, the symbol of the property class,
- c) For stainless steel, the grade and the symbol of the property class,
- d) The type of surface condition (finish and/or coating),
- e) The manufacturer's and/or distributor's identification and/or name,
- f) The manufacturing lot/batch number, and
- g) The quantity of pieces in the package.

7.2 Marking on Product

7.2.1 The marking on steel nuts shall be in accordance with **10** of IS 1367 (Part 6).

7.2.2 The marking on stainless steel nuts shall be in accordance with **11** of IS 1367 (Part 14/Sec 2).

7.3 BIS Certification Marking

The product(s) conforming to the requirements of this standard may be certified as per the conformity assessment schemes under the provisions of the *Bureau of Indian Standards Act, 2016* and the Rules and Regulations framed thereunder, and the products may be marked with the standard mark.

ANNEX A
(Clause 2)

LIST OF REFERRED STANDARDS

<i>IS No</i>	<i>Title</i>
IS 1367 (Part 1) : 2014/ ISO 8992 : 2005	Technical supply conditions for threaded steel fasteners: Part 1 General requirements for bolts, screws, studs and nuts (<i>fourth revision</i>)
IS 1367 (Part 2) : 2002/ ISO 4759-1 : 2000	Technical supply conditions for threaded steel fasteners: Part 2 Tolerances for fasteners — Bolts, screws, studs and nuts — Product grades A, B and C (<i>third revision</i>)
IS 1367 (Part 6) : 2018/ ISO 898-2 : 2012	Technical supply conditions for threaded steel fasteners: Part 6 Mechanical properties of fasteners made of carbon steel and alloy steel — Nuts with specified property classes — Coarse thread and fine pitch thread (<i>fourth revision</i>)
IS 1367 (Part 10) : 2002/ ISO 6157-2 : 1995	Technical supply conditions for threaded steel fasteners: Part 10 Surface discontinuities — Nuts (<i>third revision</i>)
IS 1367 (Part 11) : 2024/ ISO 4042 : 2022	Technical supply conditions for threaded steel fasteners: Part 11 Electroplated coating systems (<i>fifth revision</i>)
IS 1367 (Part 13) : 2020/ ISO 10684 : 2004	Technical supply conditions for threaded steel fasteners: Part 13 Hot dip galvanized coatings on threaded fasteners (<i>third revision</i>)
IS 1367 (Part 14/Sec 2) : 2023/ ISO 3506-2 : 2020	Technical supply conditions for threaded steel fasteners: Part 14 Mechanical properties of corrosion-resistant stainless — Steel fasteners, Section 2 Nuts with specified grades and property classes (<i>fifth revision</i>)
IS 1367 (Part 16) : 2002/ ISO 8991 : 1986	Technical supply conditions for threaded steel fasteners: Part 16 Designation system for fasteners (<i>third revision</i>)
IS 1367 (Part 17) : 2023/ ISO 3269 : 2019	Technical supply conditions for threaded steel fasteners: Part 17 Inspections, sampling and acceptance procedure (<i>fifth revision</i>)
IS 4218 (Part 2) : 2001/ ISO 261 : 1998	ISO general purpose metric screw threads: Part 2 General plan (<i>second revision</i>)
IS 8536 : 2021/ ISO 225 : 2010	Fasteners — Bolts, screws, studs and nuts — Symbols and descriptions of dimensions (<i>second revision</i>)
IS/ISO 10683 : 2018	Fasteners — Non-electrolytically applied zinc flake coating systems
IS 14962 (Part 2) : 2001/ ISO 965-2 : 1998	ISO general purpose metric screw threads — Tolerances: Part 2 Limits of sizes for general purpose external and internal screw threads — Medium quality

ANNEX B
(Table 1 *and* Table 2)

GAUGING OF HEXAGON NUTS WITH FLANGE

B-1 RECOMMENDED METHOD FOR GAUGING OF HEXAGON

B-1.1 For coarse pitch threads, the method of gauging shall be as shown in Fig. 3 and the dimensions of gauges shall be as given in Table 4.

B-1.2 For fine pitch threads, the method of gauging shall be as shown in Fig. 3 and the dimensions of gauges shall be as given in Table 5.

B-1.3 The nut shall be gauged using two plain ring gauges, A and B, to demonstrate the coincidental acceptability of hexagon height, wrenching height, corner fill and width across corners. Gauge A shall be placed over the nut and shall be seated on the flange. Gauge B shall be placed on the top of the nut normal to the nut axis. The two gauges shall not be in contact.

B-2 RECOMMENDED METHOD FOR GAUGING OF FLANGE THICKNESS

B-2.1 For coarse pitch threads, the method of gauging of flange thickness shall be as shown in Fig. 3 and the dimensions of gauges shall be as given in Table 4.

B-2.2 For fine pitch threads, the method of gauging shall be as shown in Fig. 3 and the dimensions of gauges shall be as given in Table 5.

B-2.3 Gauge C is a flat feeler or ring gauge. It is used to prove that the flange thickness at the junction of the gauge with the hexagon portion is equal to or greater than specified values. The acceptance criterion is that gauge C fits under gauge A without contact where the nut is seated on a flat plate.

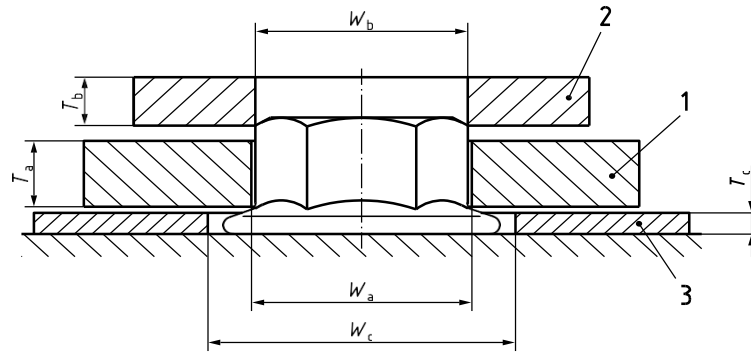

Key:

- a) gauge A
- b) gauge B
- c) gauge C

NOTE — $W_{a,min} = e_{theoretical}$

$$W_{b,max} = e_{min} - 0.01 \text{ mm}$$

$$T_{a,max} = m_{w,min}$$

FIG. 3 METHOD OF GAUGING

Table 4 Gauge Dimensions (Coarse Threads)
(Clause B-1.1 and B-2.1)

All dimensions in millimetres

SI No.	Thread <i>D</i>	Gauge A				Gauge B			Gauge C		
		<i>W_a</i>		<i>T_a</i>		<i>W_b</i>		<i>T_b</i>	<i>W_c</i>	<i>T_c</i>	
		<i>Max</i>	<i>Min</i>	<i>Max</i>	<i>Min</i>	<i>Max</i>	<i>Min</i>	<i>Min</i>	<i>Min</i>	<i>Max</i>	<i>Min</i>
(1)	(2)	(3)	(4)	(5)	(6)	(7)	(8)	(9)	(10)	(11)	(12)
i)	M5	9.25	9.24	2.50	2.49	8.78	8.77	3	14	1.08	1.07
ii)	M6	11.56	11.55	3.10	3.09	11.04	11.03	4	16	1.19	1.18
iii)	M8	15.02	15.01	4.60	4.59	14.37	14.36	4	20	1.31	1.30
iv)	M10	17.33	17.32	5.60	5.59	16.63	16.62	5	24	1.81	1.80
v)	M12	20.79	20.78	6.80	6.79	20.02	20.01	5	29	2.20	2.19
vi)	M14	24.26	24.25	7.70	7.69	23.35	23.34	6	32.5	2.55	2.54
vii)	M16	27.72	27.71	8.90	8.89	26.74	26.73	6	37	2.96	2.95
viii)	M20	34.65	34.64	10.70	10.69	32.94	32.93	6	45	3.70	3.69

Table 5 Gauge Dimensions (Fine Threads)
(Clause B-1.2 and B-2.2)

All dimensions in millimetres

SI No.	Nominal Thread Diameter <i>D</i>	Gauge A				Gauge B			Gauge C		
		W_a		T_a		W_b		T_b	W_c	T_c	
		<i>Max</i>	<i>Min</i>	<i>Max</i>	<i>Min</i>	<i>Max</i>	<i>Min</i>	<i>Min</i>	<i>Min</i>	<i>Max</i>	<i>Min</i>
(1)	(2)	(3)	(4)	(5)	(6)	(7)	(8)	(9)	(10)	(11)	(12)
i)	8	15.02	15.01	4.60	4.59	14.37	14.36	4	20	1.31	1.30
ii)	10	17.33	17.32	5.60	5.59	16.63	16.62	5	24	1.81	1.80
iii)	12	20.79	20.78	6.80	6.79	20.02	20.01	5	29	2.20	2.19
iv)	14	24.26	24.25	7.70	7.69	23.35	23.34	6	32.5	2.55	2.54
v)	16	27.72	27.71	8.90	8.89	26.74	26.73	6	37	2.96	2.95
vi)	20	34.65	34.64	10.70	10.69	32.94	32.93	6	45	3.70	3.69