

*भारतीय मानक मसौदा*

**स्लॉटेड राउंड हैड वुड पेंच — विशिष्टि**

( IS 6739 का पहला पुनरीक्षण )

*Draft Indian Standard*

**Slotted Round Head Wood Screws — Specification**

(*First Revision of IS 6739*)

ICS 21.060.10

General Engineering and Fasteners Standards  
Sectional Committee, PGD 37

Last date for receipt of comment is  
**11 August 2024**

**FOREWARD**

*(Formal Clauses will be added later)*

This Indian Standard was first published in 1972. This first revision has been taken up to keep pace with the latest technological developments and international practices. In this revision, the following modifications have been made:

- Table on dimensions has been revised,
- Mechanical requirements have been updated,
- Surface finish and surface condition requirements have been revised, and
- References have been updated.

In the formulation of this standard, considerable assistance has been derived from DIN 96 : 2016 ‘Slotted round head wood screws’.

For the purpose of deciding whether a particular requirement of this standard is complied with the final value, observed or calculated, expressing the result of a test or analysis shall be rounded off in accordance with IS 2: 2022 ‘Rules for rounding off numerical values (*second revision*).’ The number of significant places retained in the rounded off value should be the same as that of the specified value in this standard.

*Draft Indian Standard***SLOTTED ROUND HEAD WOOD SCREWS — SPECIFICATION***(First Revision of IS 6739)***1 SCOPE**

This standard specifies properties for slotted round head wood screws with a thread diameter from 1.6 mm to 8 mm for use in applications which do not require construction approval.

**2 REFERENCES**

The standards listed below contain provisions which, through reference in this text, constitute provisions of this standard. At the time of publication, the editions indicated were valid. All standards are subject to revision, and parties to agreement based on this standard are encouraged to investigate the possibility of applying the most recent edition of the standards indicated below:

<i>IS No.</i>	<i>Title</i>
IS 1367 (Part 1) : 2014/ ISO 8992 : 2005	Technical supply conditions for threaded steel fasteners: Part 1 General requirements for bolts, screws, studs and nuts
IS 1367 (Part 2) : 2002/ ISO 4759-1:2000	Technical supply conditions for threaded steel fasteners: Part 2 Tolerances for fasteners — Bolts, screws, studs and nuts — Product grades A, B and C ( <i>third revision</i> )
IS 1367 (Part 9/Sec) : 1993/ ISO 6157-1 : 1988	Technical supply conditions for threaded steel fasteners: Part 9 Surface discontinuities, Section 1 Bolts, screws and studs for general applications ( <i>third revision</i> )
IS 1367 (Part 11) : 2024/ ISO 4042 : 2022	Technical supply conditions for threaded steel fasteners: Part 11 Electroplated coating systems ( <i>fourth revision</i> )
IS 1367 (Part 14/Sec 1) : 2023/ ISO 3506-1 : 2000	Technical supply conditions for threaded steel fasteners: Part 14 Mechanical properties of corrosion-resistant stainless-steel fasteners, Section 1 Bolts, screws and studs with specified grades and property classes ( <i>fifth revision</i> )
IS 1367 (Part 17) : 2005/ISO 3269 : 2000	Technical supply conditions for threaded steel fasteners: Part 17 Inspections, sampling and acceptance procedure ( <i>fourth revision</i> )
IS 8536 : 2021	Fasteners — Bolts, screws, studs and nuts — Symbols and descriptions of dimensions ( <i>first revision</i> )
Doc. No.: PGD 37 (25490)	Passivation of corrosion-resistant stainless-steel fasteners

**3 SYMBOLS**

For the purpose of this standard, the symbols given in IS 8536 shall apply.

**4 DIMENSIONS**

The dimension of slotted round head wood screws shall be given in Fig. 1 and Table 1.

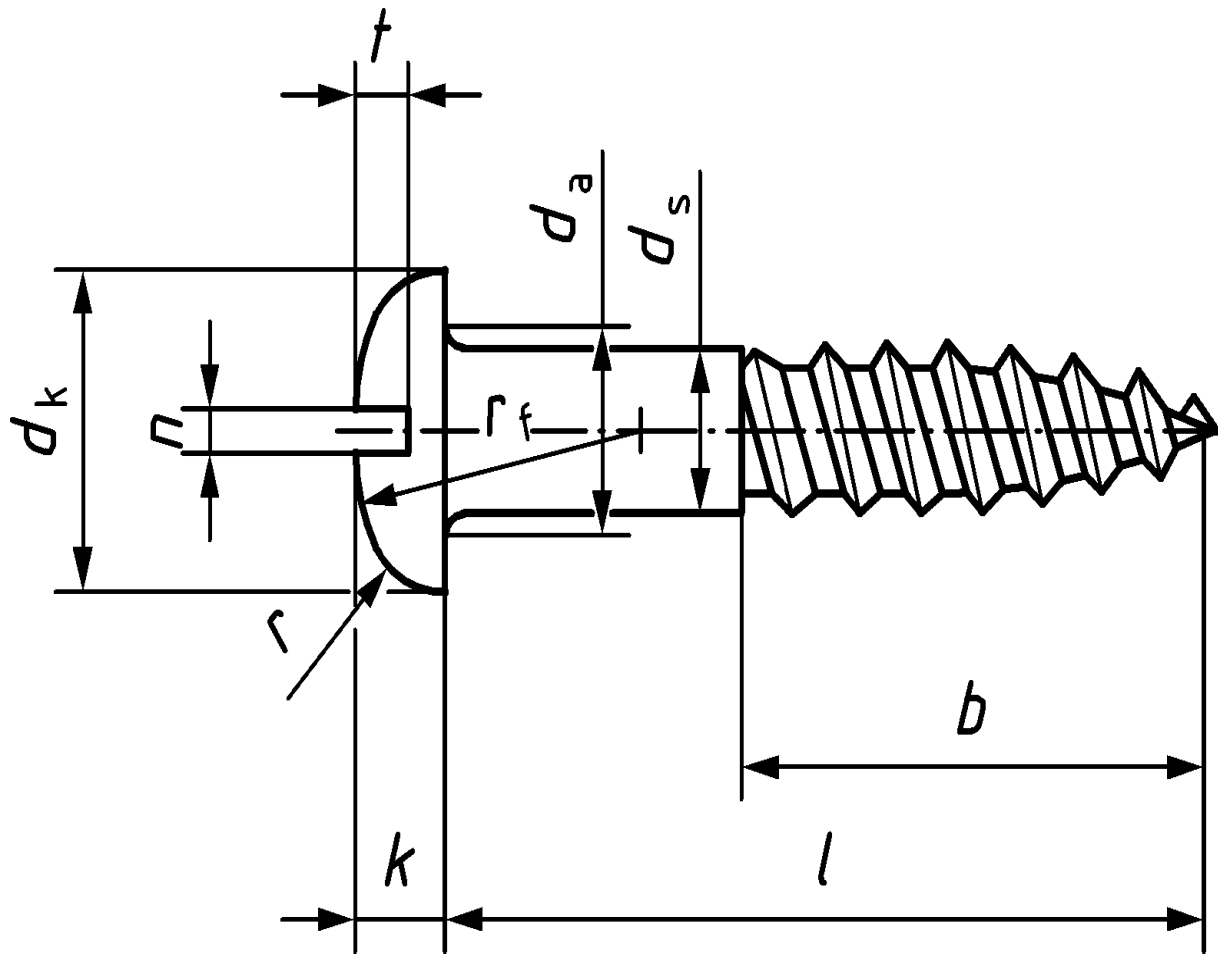

$$b \geq 0.6l$$

FIG. 1 DIMENSIONS OF SLOTTED ROUND HEAD WOOD SCREWS

Table 1 Dimensions of Slotted Round Head Wood Screw

(Clause 4)

All dimensions are in millimetres.

SI No.	Thread size		(1.6)	2	2.5	3	3.5	4	4.5	5	(5.5)	6	(7)	(8)
(1)	(2)		(3)	(4)	(5)	(6)	(7)	(8)	(9)	(10)	(11)	(12)	(13)	(14)
i)	$d_s$	<i>Max</i>	1.60	2.00	2.50	3.00	3.50	4.00	4.50	5.00	5.50	6.00	7.00	8.00
		<i>Min</i>	1.20	1.60	2.10	2.60	3.02	3.52	4.02	4.52	5.02	5.52	6.42	7.42
ii)	$d_a$	<i>Max</i>	2.2	2.8	3.3	3.8	4.3	5	5.5	6	6.6	7.2	8.2	10.2
iii)	$d_k$	Nominal Size	3.2	4	5	6	7	8	9	10	11	12	14	16
		<i>Max</i>	3.58	4.38	5.38	6.38	7.45	8.45	9.45	10.45	11.55	12.55	14.55	16.55
		<i>Min</i>	2.83	3.62	4.62	5.62	6.55	7.55	8.55	9.55	10.45	11.45	13.45	15.45
iv)	$k$	Nominal Size	1.1	1.4	1.7	2.1	2.4	2.8	3.1	3.5	3.8	4.2	4.9	5.6
		<i>Max</i>	1.30	1.60	1.90	2.30	2.60	3.00	3.34	3.74	4.04	4.44	5.14	5.84
		<i>Min</i>	0.90	1.20	1.50	1.90	2.10	2.60	2.86	3.26	3.56	3.96	4.66	5.36
v)	$r_f$	$\approx$	2.6	3.2	4.0	4.8	5.6	6.4	7.2	8.0	8.8	9.6	11.2	12.8
vi)	$n$	Nominal size	0.4	0.5	0.6	0.8	0.8	1	1	1.2	1.2	1.6	2	2
		<i>Max</i>	0.60	0.70	0.80	1.00	1.00	1.20	1.20	1.51	1.51	1.91	2.31	2.31
		<i>Min</i>	0.46	0.56	0.66	0.86	0.86	1.06	1.06	1.26	1.26	1.66	2.06	2.06
vii)	$r$	$\approx$	1.3	1.6	2.0	2.4	2.8	3.2	3.6	4.0	4.4	4.8	5.6	6.4
		<i>Max</i>	0.7	0.9	1.1	1.35	1.6	1.8	2.0	2.3	2.5	2.7	3.2	3.6



Lengths exceeding 80 mm shall be graded in 10 mm increments.

NOTES

1 Bracketed sizes should be avoided if possible.

2 Commercial sizes of wood screws are those given in the zone between the stepped lines.

## 5 TECHNICAL DELIVERY CONDITIONS

The various requirements of slotted round head wood screws shall be as given in Table 2 and Annex A.

**Table 2 Technical Delivery Conditions and Reference Standards**  
(Clause 5)

Material	Steel	Stainless steel	Non-ferrous metal
	Grade at the manufacturer's discretion	A2 to A5 in accordance with IS 1367 (Part 14/Sec 1)	Copper-zinc alloy <sup>3)</sup>
General requirements	IS 1367 (Part 1)		
Threads and thread ends	see Annex A		
Limit deviations. geometrical tolerances	Product grade	C	
	Standard	IS 1367 (Part 2) <sup>1)</sup>	
Surface finish — Coating	As processed  IS 1367 (Part 11) applies with regard to electroplating	Plain <sup>2)</sup>	As processed  IS 1367 (Part 11) applies with regard to electroplating
Surface condition	IS 1367 (Part 9/Sec 1) applies with regard to limits for surface discontinuities	—	—
Acceptance inspection	IS 1367 (Part 17)		
<sup>1)</sup> IS 1367 (Part 2) : 2002 currently applies only for screws with ISO metric screw thread and for tapping screws. Unless given in this standard. The permissible deviations and geometrical tolerances specified in 1367 (Part 2) : 2002 shall be adopted analogously for wood screws. <sup>2)</sup> Passivation in accordance with Doc. No.: PGD 37 (25490) is recommended. <sup>3)</sup> The specific grade of copper-zinc alloy shall be in agreement between the user/purchaser and the manufacturer.			

## 6 DESIGNATION

A wood screw conforming to the requirements of this standard shall be designated by the nominal length, type of material and the IS No. of this standard.

*Example:*

1) Designation of a slotted round head wood screw with a thread size 4 mm with a length  $l$  (nominal size) = 20 mm, made of steel (St):

Wood screw IS 6736 — 4 × 20 — St

2) Designation of a slotted round head wood screw with a thread size 5 mm with a length  $l$  (nominal

size) = 40 mm, made of stainless steel of grade A2 shall be:

Wood screw IS 6736 — 5 × 40 — St — A2

## **7 MARKING**

**7.1** The label of individual boxes containing the wood screws shall be marked with the following information:

- a) Manufacturer's name or trade-mark,
- b) Designation, and
- c) Batch No./month and year of manufacturing, and
- d) Quantity contained in the box.

### **7.2** *BIS Certification Marking*

The product(s) conforming to the requirements of this standard may be certified as per the conformity assessment schemes under the provisions of the *Bureau of Indian Standards Act, 2016* and the Rules and Regulations framed thereunder. and the products may be marked with the standard mark.



**ANNEX A**  
(Clause 5)

**DIMENSIONS OF THREADS AND THREAD ENDS**

**A-1 DIMENSIONS OF THREADS AND THREAD ENDS**

The dimensions of threads and thread ends shall be as given in Fig. 2 and Table 3.



Designation of a wood screw thread of nominal diameter  $d_1 = 4$  mm:

FIG. 2 THREADS AND THREAD ENDS

**Table 3 Dimensions of Threads and Thread Ends**  
(Clause A-1)

Sl No.	$d_1$	$d_3$	<b>P</b>	Perm. dev.
	<b>h15</b>	<b>h15</b>	Nominal Size	
(1)	(2)	(3)	(4)	(5)
i)	1.6	1.1	0.7	± 0.07
ii)	2	1.4	0.9	± 0.09
iii)	2.5	1.7	1.1	± 0.11
iv)	3	2.1	1.35	± 0.14
v)	3.5	2.4	1.6	± 0.16
vi)	4	2.8	1.8	± 0.18
vii)	4.5	3.1	2	± 0.2
viii)	5	3.5	2.2	± 0.22
ix)	5.5	3.8	2.4	± 0.24
x)	6	4.2	2.6	± 0.26
xi)	7	4.9	3.2	± 0.32
xii)	8	5.6	3.6	± 0.36
xiii)	10	7	4.5	± 0.45
xiv)	12	9	5	± 0.5
xv)	16	12	6	± 0.6
xvi)	20	15	7	± 0.7

Size in brackets are to be avoided as far as possible