

**BUREAU OF INDIAN STANDARDS**  
**DRAFT FOR COMMENTS ONLY**

*Not to be reproduced without permission of BIS or used as Standard*

Doc No.: PGD 33 (23034)

July 2023

भारतीय मानक मसौदा  
इनवॉल्यूट साइडेड स्प्लाइन्स के लिए आयाम  
( IS 3665 का पहला पुनरीक्षण )

*Draft Indian Standard*  
**Dimensions for Involute Sided Splines**  
( *First Revision of IS 3665* )

ICS 21.120.30

Transmission Devices Sectional Committee,  
PGD 33

Last Date for Comments: 17-09-2023

## FOREWORD

*(formal clause to be added later on)*

Splined shafts generally have the following three types of applications:

- a) Coupling shafts when relatively heavy torques are to be transmitted without slippage,
- b) Transmitting power to floating or permanently fixed gears, pulleys and other rotating members, and
- c) Coupling parts that may require frequent removal for indexing or change of angular position.

External and internal splines are very extensively used in the automobile, machine tools and other industries. This standard has been prepared to rationalize the production and to facilitate interchangeability of external and internal splines.

This standard deals with involute sided splines of 30° pressure angle for general engineering purposes, Separate standards on straight sided splines have already been prepared (*see* IS 2327 : 1993 and IS 2610 : 1989).

The dimensions and fits given in the tables are based on the basic hole system. In this system the dimensions of the internal splines are the basis and variations in fit are obtained by varying the allowance on the external splines.

The tolerances for the spline tooth thickness and space width are given in Table 12. The instructions for the use of table is explained in Annex A. The tolerance on major and minor diameters shall be according to the system of limits and fits specified in IS 919 (Part 1) : 2014 & IS 919 (Part 2) : 2014.

Separate standards on gauging practice and the relevant manufacturing tools for splines are under preparation.

As far as possible, the major diameters of external splines are given so as to end in numbers 0, 2, 5 and 8 which are standard diameters for ball bearings

This standard is based on the following principles:

- a) To cover the standard modules conforming to IS 2535 : 1963.
- b) The same reference profile is used for all pitches and consequently, used for all profiles.
- c) Centring by side fit or diameter fit.
- d) Use of profile displacement for the purpose of obtaining optimum utilization of materials.

This standard is based on draft standard DIN 5480 : 1964 Blatt 1 to 14 'Zahnwellen Verbindungen mit Evolventenflanken (Involute sided splines)' issued by the Deutscher Normenausschuss.

For the purpose of deciding whether a particular requirement of this standard is complied with the final value, observed or calculated, expressing the result of a test or analysis shall be rounded off in accordance with IS 2 : 2022 'Rules for rounding off numerical values (*second revision*).'

*Draft Indian Standard*

**Dimensions for Involute Sided Splines**

( *First Revision of IS 3665* )

**1 SCOPE**

**1.1** This standard covers the dimensions, for straight involute spline of 30° pressure angle, with three different types of fits, namely, major diameter fit, minor diameter fit and side fit.

**1.2** Involute splines of modules (1), 1.25, (1-5), 2, (2.5), 3, (4), 5, (6), 8 and (10) are covered in this standard. The values given within brackets are non-preferred.

**2 REFERENCES**

The following standards contain provisions, which through reference in this text, constitute provisions of this standard. At the time of publication the editions indicated were valid. All standards are subject to revision and encouraged to investigate the possibility of applying the most recent editions of the standards.

<i>IS No.</i>	<i>Title</i>
IS 919 (Part 1) : 2014	Geometrical Product Specifications (GPS) - ISO Code System for Tolerances on Linear Sizes Part 1 Basis of Tolerance, Deviation and Fits ( <i>Third Revision</i> )
IS 919 (Part 2) : 2014	Geometrical product specifications (GPS) - ISO code system for tolerances on linear sizes: Part 2 tables of standard tolerance classes and limit deviation for holes and shafts ( <i>Second Revision</i> )
IS 2327 : 1993	Straight - Sided splines for cylindrical shafts with internal centering - Dimensions, tolerances and verification ( <i>first revision</i> )
IS 2535 : 1963	Cylindrical gears for general and heavy engineering
IS 2610 : 1989	Power transmission - Straight sided splines for machine tools dimensions ( <i>first revision</i> )

**3 DEFINITIONS**

For the purpose of this standard, the following definitions shall apply.

**3.1 Actual Space Width** — The circular width on the pitch circle of any single space (*see* Fig. 1).

**3.2 Actual Tooth Thickness** — The circular thickness on the pitch circle of any single tooth (*see* Fig. 2).

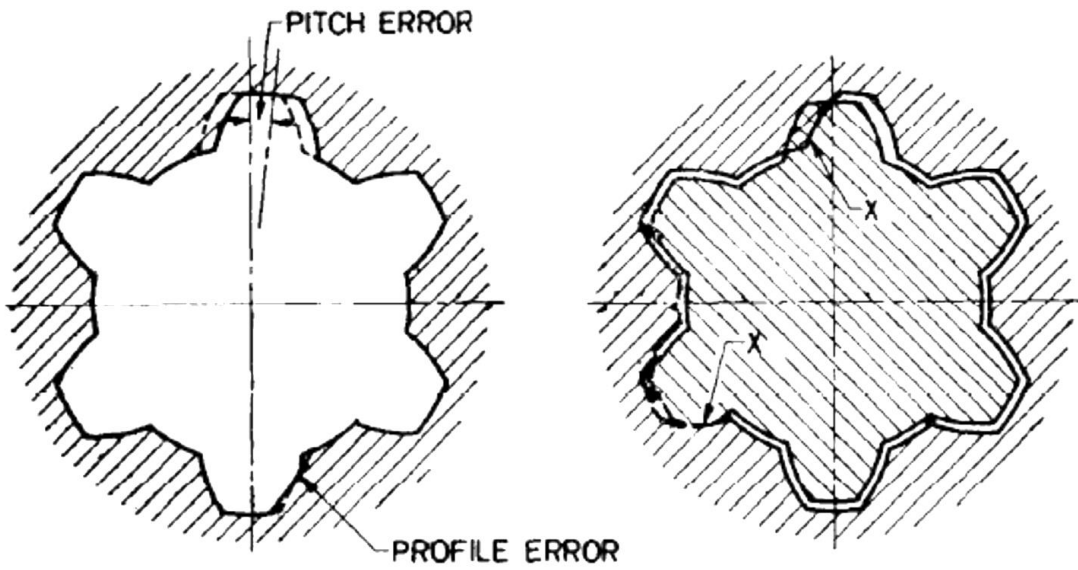

a) Each Space is Basic Width

b) Perfect External Spline with Basic Tooth Thickness Interferes at X

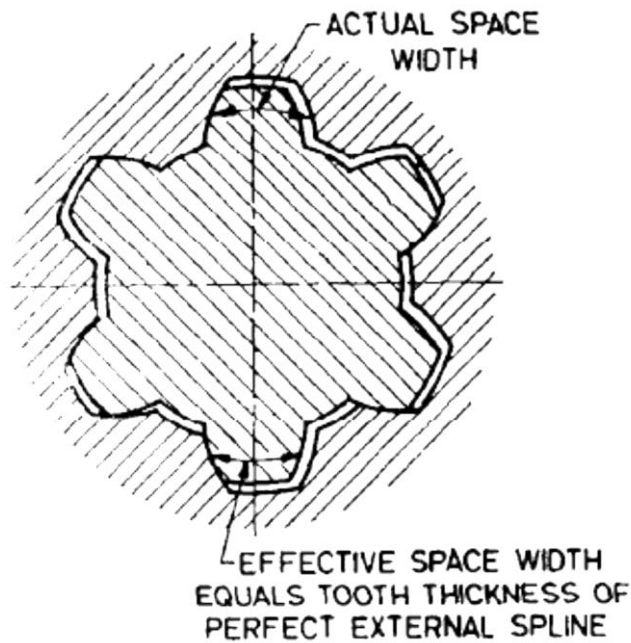

c) The perfect External Spline fits in any Position, if all Spaces of the Internal Spline are widened by the Amount of interference

FIG. 1 EFFECT OF INTERNAL SPLINE ERRORS

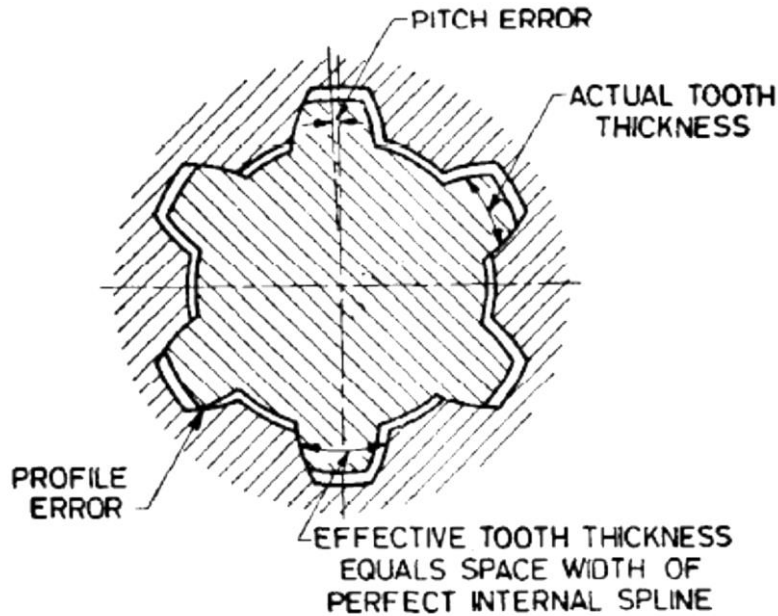

FIG. 2 EFFECT OF EXTERNAL SPLINE ERRORS

**3.3 Base Circle Diameter** — The diameter of the circle from which involute spline tooth profiles are constructed.

**3.4 Effective Clearance** — The difference between the effective space width of the internal spline and the effective tooth thickness of the mating external spline (*see* Fig.3).

**3.5 Effective Error** — The accumulated effect of the spline errors on the fit with the mating parts.

**3.6 Effective Space Width of an Internal Spline** — The circular tooth thickness on the pitch *circle* of an imaginary perfect external spline which would fit the internal spline without looseness or interference (*see* Fig. 1).

**3.7 Effective Tooth Thickness of an External Spline** — The circular space width on the pitch circle of an imaginary perfect internal spline which would fit the external spline without looseness or interference (*see* Fig.2).

**3.8 Error Allowance** — The permissible effective error.

**3.9 Involute Spline** — The spline having teeth with involute profiles.

**3.10 Machining Tolerance** — The permissible variation in actual space width or actual tooth thickness (*see* Fig. 3).

**3.11 Main Pressure Angle ( $\alpha_0$ )** — The pressure angle at the pitch point.

**3.12 Major Diameter** — The diameter of the outermost surface of the spline. It is the root diameter of the internal spline or the tip diameter of the external spline.

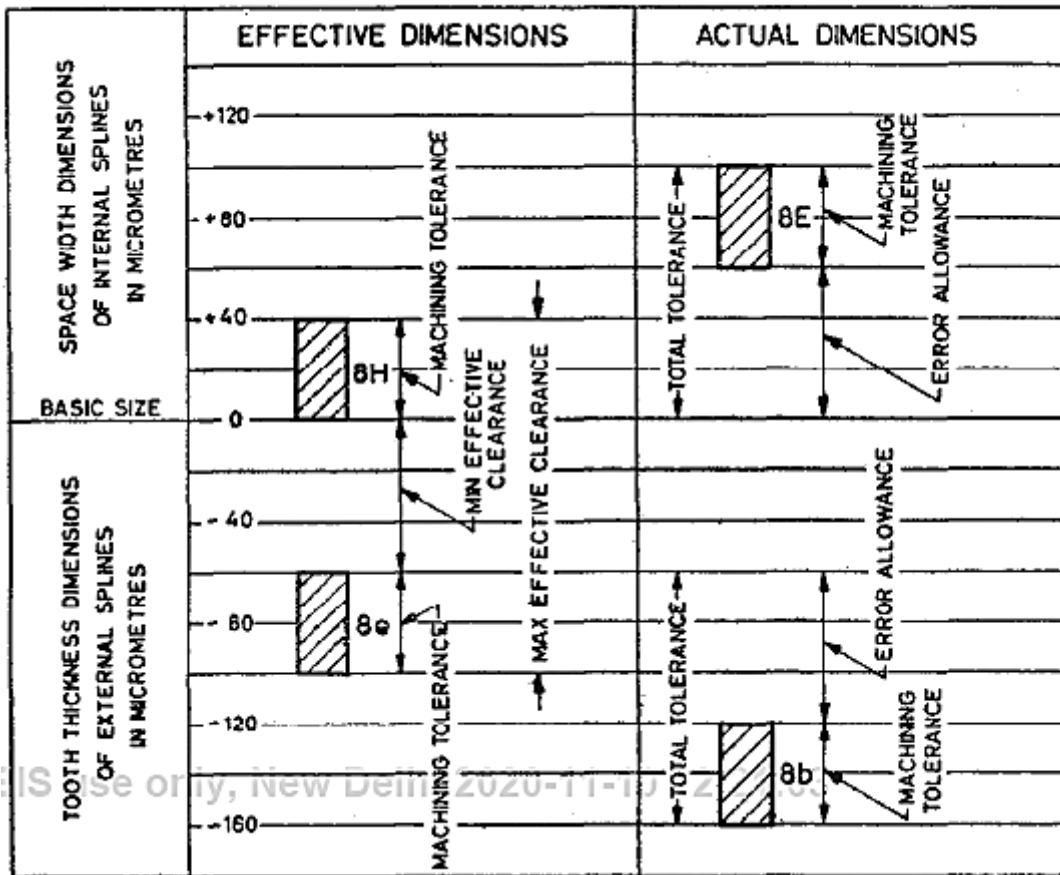

FIG. 3 FIT DIAGRAM OF SPLINE ASSEMBLY  
 120 × 114 × 38 × 8HE/8eb IS 3665

**3.13 Minor Diameter** — The diameter of the innermost surface of the spline. It is the tip diameter of the internal spline or the root diameter of the external spline.

**3.14 Module ( $m$ )** — The ratio of the pitch circle diameter to the number of spline teeth.

**3.15 Nominal Clearance** — The difference between the actual space width of an internal spline and the actual tooth thickness of the mating external spline. This does not define the fit between the mating members, because of the effect of errors.

**3.16 Pitch Circle Diameter** — The diameter of an imaginary reference circle (pitch circle) from which all transverse dimensions are derived.

**3.17 Pitch Point** — The point of intersection of the spline tooth profile with the pitch circle.

**3.18 Pressure Angle** — The acute angle between a line tangent to a profile of the spline and a radial line through the point of tangency. Unless otherwise specified the pressure angle shall mean the main pressure angle.

**3.19 Profile Displacement ( $xm$ )** — The displacement of the basic rack either away or towards the reference cylinder and is denoted by  $xm$ . The former is taken as positive and latter as negative profile displacement.

**3.20 Spline** — A machine element consisting of integral keys (spline teeth) or keyways (spaces) equally spaced around a circle or a portion thereof.

**3.21 Total Tolerance** — The sum of the machining tolerance and the error allowance (*see* Fig. 3).

#### 4 TYPES

**4.1 External Spline** — An involute spline whose tip surface is external to the root surface.

**4.2 Internal Spline** — An involute spline whose tip surface is internal to the root surface.

#### 5 EFFECTIVE AND ACTUAL DIMENSIONS

The effective dimensions and actual dimensions together determine the fit of a spline assembly.

#### 6 DIMENSIONS, TOLERANCES AND FITS

**6.1** Reference profile for the different pitches shall be as given in Fig. 4.

**6.2 Major Diameter of Internal Spline ( $d_1$ )** — This is the reference diameter of the profile, and the value shall be according to Tables 1 to 11.

**6.3 Profile Displacement ( $xm$ )** — The value of the profile displacement shall be calculated from the following formula (*see* Tables 1 to 11):

$$xm = 1/2 (d_1 - m.z - 1.1 m)$$

The value shall be from - 0.05  $m$  to + 0.45  $m$ .

**6.4 Number of Teeth ( $z$ )** — The number of teeth shall be calculated from the following formula (*see* Tables 1 to 11):

$$z = \frac{1}{m}(d_1 - 2xm - 1.1 m)$$

where  $d_1$  is the major diameter of the internal spline.

**6.5 Minor Diameter of the Internal Spline ( $d_2$ )** — The value of the minor diameter of the internal spline shall be calculated from the following formula (*see* Tables 1 to 11):

$$D_2 = m.z + 2 xm - 0.9m = d_1 - 2 m$$

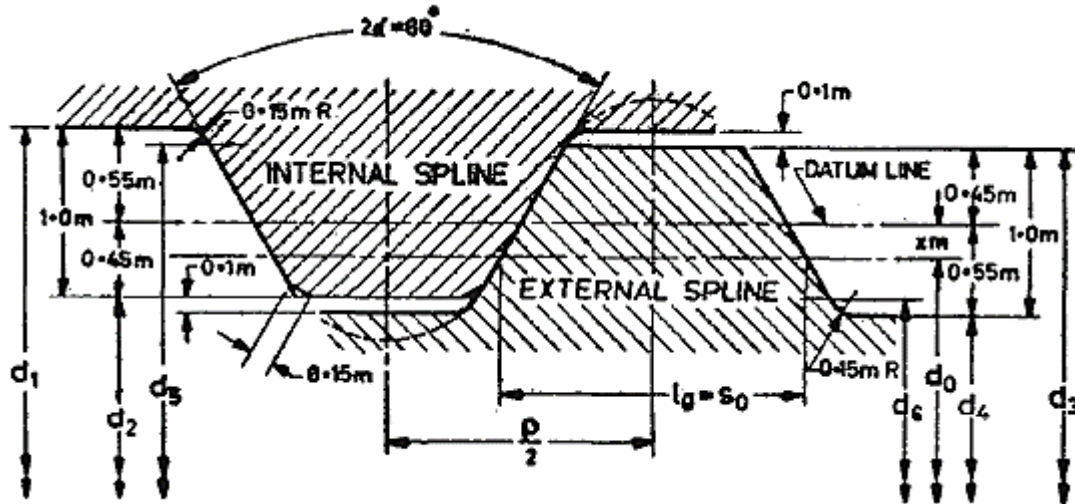

FIG. 4 REFERENCE PROFILE

**6.6 Major Diameter of the External Spline ( $d_3$ )** — The value of the major diameter of the external spline shall be calculated from the following formula (see Tables 1 to 11):

$$d_3 = m.z + 2xm + 0.9m = d_1 - 0.2m$$

**6.7 Minor Diameter of the External Splines ( $d_4$ )** — Minor diameter of the external splines shall be calculated from the following formula (see Tables 1 to 11):

$$d_4 = m.z + 2xm - 1.1m = d_1 - 2.2m$$

**6.8 Space Width and Tooth Thickness ( $l_0$  and  $s_0$ )** — The value of the tooth thickness and space width shall be calculated from the following formula (see Tables 1 to 11):

$$l_0 \text{ And } s_0 = m \frac{\pi}{2} + 2xm \cdot \tan \alpha_0$$

**6.9** The measuring pin diameter, the measurement over pins for the external splines and the measurement between pins for the internal splines shall be as given in Tables 1 to 11 (see Fig. 5).

**6.9.1 Tolerance on Measurement over Pins** — The tolerance values on effective and actual measurement over pins shall be obtained by multiplying the tolerance values on the effective and actual tooth thickness by the deviation factor  $f$ . (Tables 1 to 11).

**6.9.2 Tolerance on Measurement Between Pins** — The tolerance on effective and actual measurement between pins shall be obtained by multiplying the tolerance values on the effective and actual space width by the deviation factor (Tables 1 to 11).



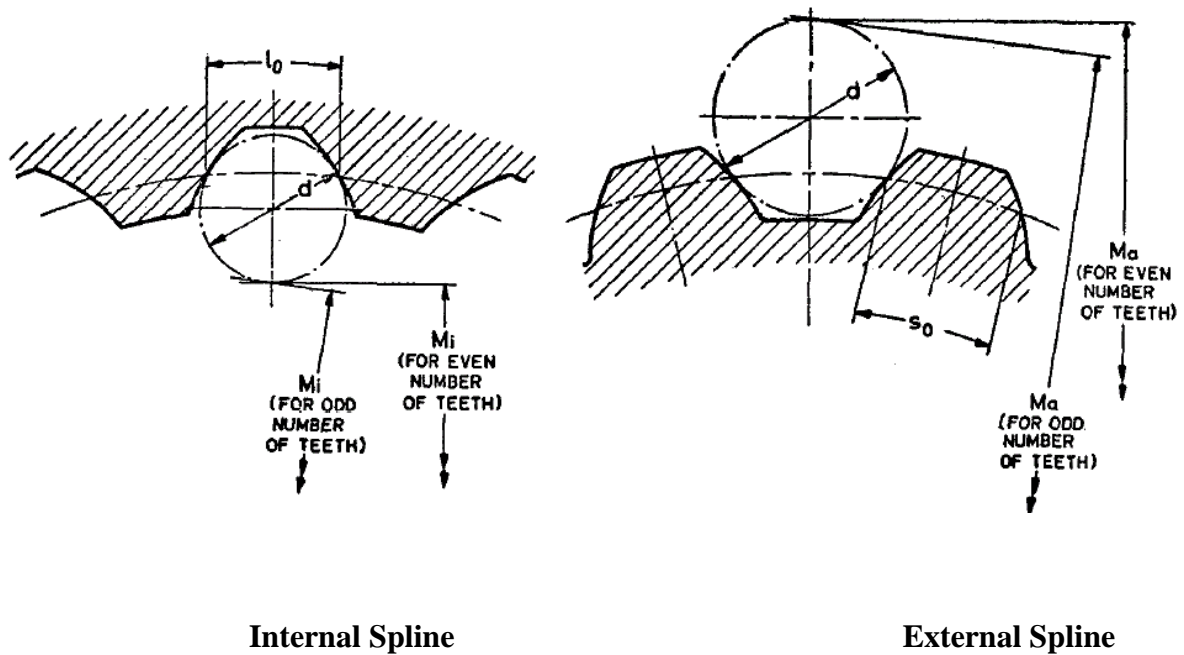

FIG. 5 MEASUREMENT BETWEEN PINS AND MEASUREMENT OVER PINS

**6.10** The thickness of external splines over a specified number of teeth shall be according to Tables 1 to 11.

**6.10.1** The tolerance on the effective and actual thickness of external splines over a specified number of teeth shall be the product of the tolerance on the effective and actual tooth thickness and the deviation factor 0.866.

### 6.11 Types of Fits

**6.11.1 Major Diameter Fit** — In this type of fit, the major diameter of the external and internal splines have the same nominal diameter  $d_1$ . There shall be circular clearance between the internal spline space width and external spline tooth thickness.

**6.11.1.1** The recommended tolerance values for the internal spline minor diameters ( $d_2$ ) shall be H11 and the tolerance values for the external spline minor diameters ( $d_4$ ) shall be h14. An example of major diameter fit is given in Fig. 6.

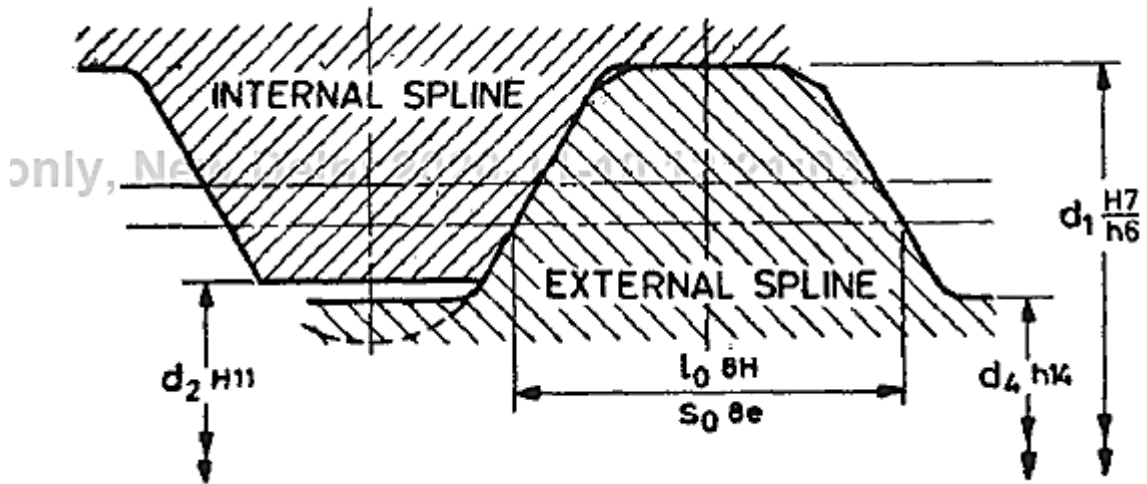

FIG.6 EXAMPLE OF MAJOR DIAMETER FIT

**6.11.2 Minor Diameter Fit** — In this type of fit, the minor diameter of the internal and external splines shall have the same nominal diameter  $d_2$ . There shall be circular clearance between the internal spline space width and external spline tooth thickness.

**6.11.2.1** The recommended tolerance values for the internal spline major diameters ( $d_1$ ) shall be H14 and the tolerance values for the external spline major diameters ( $d_3$ ) shall be h11. An example of minor diameter fit is given in Fig. 7.

**6.11.3 Side Fit** — In this type of fit, the mating members contact on the sides of the teeth only. There shall be clearance between the major diameters and minor diameters. The tolerance values for spindle tooth thickness and space width for the spline qualities 7, 8, 9 and 10 shall be as given in Table 12.

NOTE — Instructions for the use of Table 12 is given in Appendix A.

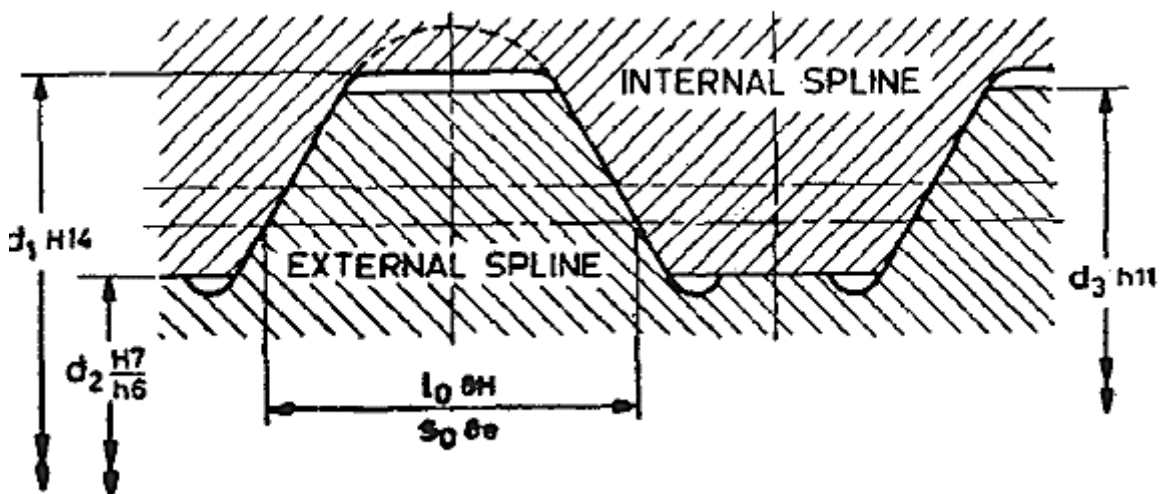

FIG. 7 EXAMPLE OF MINOR DIAMETER FIT

**6.11.3.1** The recommended tolerance values for the major diameters of internal spline ( $d_1$ ) shall be H14, the minor diameters of internal spline ( $d_2$ ) shall be H11, the major diameters of external spline ( $d_3$ ) shall be h11 and the minor diameters of external spline ( $d_4$ ) shall be h14. An example of side fit is shown in Fig. 8.

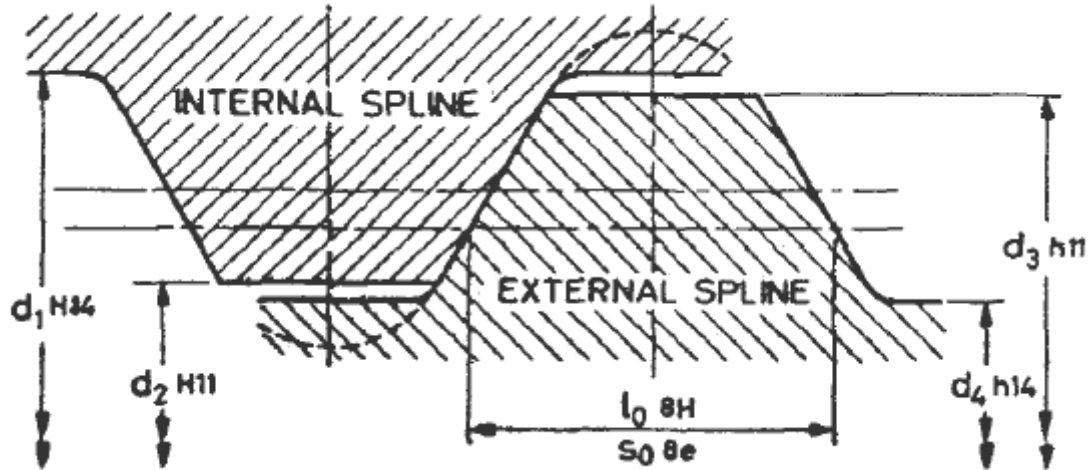

FIG. 8 EXAMPLE OF SIDE FIT

**6.11.4** A typical example of effective tooth thickness, effective space width, actual tooth thickness and the actual space width for three types of fits, namely, press fit, locating fit and sliding fit, is shown in Table 13

## 7 DESIGNATION

### 7.1 Side Fit

**7.1.1** An involute sided spline of a spline assembly of side fit shall be designated by the type of spline, nominal size ( $d_1 \times d_2$ ), number of teeth of the spline, the tolerance on the effective and actual dimensions; of space width for internal splines, and of tooth thickness for external spline, followed by the number of this standard.

*Example:*

An external involute spline of nominal size 120 x 114 mm with 38 spline teeth, and with the tolerance symbols 8e and 8b on the effective and actual tooth thickness shall be designated as:

External Involute Spline 120 × 114 × 38 × 8eb IS: 3665

**7.1.2** A side fitted spline assembly shall be designated by the nominal size, number of teeth  $d$  the spline, the effective and actual fit of the spline teeth and the number of this standard.

*Example:*

A spline assembly of nominal size  $120 \times 114$ , with 38 spline teeth and the fit 8 HE/8eb on the effective and actual spline teeth shall be designated as:

Spline Assembly  $120 \times 114 \times 38 \times 8$  HE/8eb IS: 3665

**7.2 Diameter Fit** — Spline assembly of major and minor diameter fit shall be designated as in **6.1.2** along with the value of fit on their respective diameters.

*Examples:*

a) A spline assembly of major diameter fit of H7/h6 of external involute spline,  $120 \times 114 \times 38 \times 8$ eb and internal involute spline  $120 \times 114 \times 38 \times 8$  HE shall be designated as:

Spline Assembly  $120$  H7/h6  $\times 114 \times 38 \times 8$  HE/8eb IS: 3665

b) A spline assembly of minor diameter fit of H7/h6 of external involute spline,  $120 \times 114 \times 38 \times 8$ eb and internal involute spline  $120 \times 114 \times 38 \times 8$  HE shall be designated as:

Spline Assembly  $120$  X  $114$  H7/h6 X  $38$  X  $8$  HE/8eb IS: 3665

## **8 BIS CERTIFICATION MARKING**

The product(s) conforming to the requirements of this standard may be certified as per the conformity assessment schemes under the provisions of the Bureau of Indian Standards Act, 2016 and the Rules and Regulations framed thereunder, and the product(s) may be marked with the Standard Mark.

**Table 1 Dimensions for Involute Splines of Module 1***(Clauses 6.2 to 6.10)*

All dimensions in millimetres.

NOMINAL SIZE										INTERNAL SPLINE			EXTERNAL SPLINE				
										Pin Dia	Measurement Between pins	Deviation Factor	Pin Dia	Measurement Over Pins	Deviation Factor	Tooth Thickness Over z' Teeth	
																	Tooth thickness deviation factor 0.866
d <sub>1</sub> × d <sub>2</sub>	Z	d <sub>0</sub>	D	d <sub>3</sub>	d	d Min	d Max	xm	l <sub>a</sub> = s <sub>a</sub>	d	M	f	d	M <sub>a</sub>	f <sub>a</sub>	Z'	
8×6 10×8	6 8	6 8	5.196 6.928	7.8 9.8	5.8 7.8	7.86 9.86	5.94 8.94	+0.45 +0.45	2.090 2.090	1.75 1.75	4.367 6.368	1.64 1.66	4.00 3.00	14.173 14.103	1.01 1.11	2 2	4.810 4.903
12×10 15×13	10 13	10 13	8.660 11.258	11.8 14.8	9.8 12.8	11.86 14.87	9.94 12.93	+0.45 +0.45	2.090 2.090	1.75 1.75	8.369 11.273	1.67 1.67	2.75 2.50	15.615 17.992	1.17 1.24	- 3	- 7.857
17×15 18×16	15 16	15 16	12.990 13.856	16.8 17.8	14.8 15.8	16.87 17.87	14.93 15.93	+0.45 +0.45	2.090 2.090	1.75 1.75	13.286 14.369	1.68 1.69	2.25 2.25	19.431 20.541	1.31 1.33	- -	- -
20×18 22×20	18 20	18 20	15.588 17.321	19.8 21.8	17.8 19.8	19.87 21.87	17.93 19.93	+0.45 +0.45	2.090 2.090	1.75 1.75	16.370 18.370	1.70 1.70	2.25 2.25	22.568 24.592	1.35 1.37	4 4	10.810 10.903
25×25 28×26	24 26	24 26	20.785 22.517	24.8 27.8	22.8 25.8	24.87 27.88	22.93 25.92	-0.05 +0.45	1.513 2.090	1.75 1.75	21.311 24.370	2.00 1.71	2.00 2.00	27.109 29.982	1.54 1.46	- 5	- 13.903
30×28 32×30	28 30	28 30	24.249 25.981	29.8 31.8	27.8 29.8	29.88 31.88	27.92 29.92	+0.45 +0.45	2.090 2.090	1.75 1.75	26.370 28.370	1.71 1.71	2.00 2.00	31.992 34.002	1.47 1.48	- 6	- 16.810
35×33 37×35	34 36	34 36	29.445 31.177	34.8 36.8	32.8 34.8	34.88 36.88	32.92 34.92	-0.05 -0.05	1.513 1.513	1.75 1.75	31.331 33.334	1.90 1.89	2.00 2.00	37.127 39.129	1.59 1.59	6 -	16.497 -
38×36 40×38	36 38	36 38	31.177 32.909	37.8 39.8	35.8 37.8	37.88 39.88	33.92 37.92	+0.45 +0.45	2.090 2.090	1.75 1.75	34.370 36.370	1.72 1.72	2.00 2.00	40.025 42.032	1.51 1.52	7 7	19.810 19.903
42×40	40	40	34.641	41.8	39.8	41.88	39.92	+0.45	2.090	1.75	38.370	1.72	2.00	44.038	1.53	-	-

**Table 2 Dimensions for Involute Splines of Module (1.25)**  
(Clauses 6.2 to 6.10)

All dimensions in millimetres.

NOMINAL SIZE										INTERNAL SPLINE			EXTERNAL SPLINE				
										Pin Dia	Measurement Between pins	Deviation Factor	Pin Dia	Measurement Over Pins	Deviation Factor	Tooth Thickness Over z' Teeth	
																	Tooth thickness deviation factor 0.866
d <sub>1</sub> × d <sub>2</sub>	Z	d <sub>0</sub>	D	d <sub>3</sub>	d	d Min	d Max	xm	l <sub>a</sub> = s <sub>a</sub>	d	M	f	d	M <sub>a</sub>	f <sub>a</sub>	Z'	
10×7.5	6	7.50	6.495	9.75	7.25	9.81	7.44	+0.5625	2.613	2.25	5.276	1.71	4.50	16.629	1.03	2	6.013
12×9.5	8	10.00	8.660	11.75	9.25	11.81	9.44	+0.3125	2.324	2.25	7.230	2.13	3.00	15.554	1.20	2	5.879
15×12.5	10	12.50	10.825	14.75	12.25	14.82	12.43	+0.5625	2.613	2.25	10.276	1.72	3.25	19.075	1.19	-	-
17×14.5	12	15.00	12.990	16.75	14.25	16.82	14.43	+0.3125	2.325	2.25	12.249	1.95	2.75	20.059	1.31	3	9.513
18×15.5	13	16.25	14.073	17.75	15.25	17.82	15.43	+0.1875	2.180	2.25	13.099	2.08	2.50	20.360	1.38	3	9.446
20×17.5	14	17.50	15.155	19.75	17.25	19.82	17.43	+0.5625	2.613	2.25	15.276	1.72	3.00	23.602	1.28	3	9.876
22×19.5	16	20.00	17.321	21.75	19.25	21.82	19.43	+0.3125	2.324	2.25	17.257	1.88	2.5	24.477	1.41	-	-
25×22.5	18	22.50	19.486	24.75	22.25	24.82	22.43	+0.5625	2.613	2.25	20.276	1.73	2.75	28.050	1.36	4	13.513
28×25.5	21	26.25	22.733	27.75	25.25	27.83	24.42	+0.1875	2.180	2.25	23.170	1.91	2.50	30.481	1.47	4	13.313
30×27.5	22	27.50	23.816	29.75	27.25	29.83	27.42	+0.5625	2.613	2.25	25.276	1.73	2.75	33.103	1.40	-	-
32×29.5	24	30.00	25.981	31.75	29.25	31.83	29.42	+0.3125	2.324	2.25	27.264	1.83	2.50	34.540	1.48	5	17.013
35.32.5	26	32.50	28.146	34.75	32.25	34.83	32.42	+0.5625	2.613	2.25	30.276	1.73	2.50	37.477	1.46	5	17.379
37×34.5	28	35.00	30.311	36.75	34.25	36.83	34.42	+0.3125	2.324	2.25	32.266	1.81	2.50	39.561	1.51	-	-
38×35.5	29	36.25	31.393	37.75	35.25	37.83	35.42	+0.1875	2.180	2.25	33.200	1.85	2.50	40.540	1.53	-	-
40×37.5	30	37.50	32.476	39.75	37.25	39.83	37.42	+0.5625	2.613	2.25	35.276	1.73	2.50	42.502	1.48	6	21.013
42×39.5	32	40.00	34.641	41.75	39.25	41.83	39.42	+0.3125	2.324	2.25	37.267	1.80	2.50	44.577	1053	6	20.879
45×42.5	34	42.50	36.806	44.75	42.25	44.83	42.42	+0.5625	2.613	2.25	40.276	1.73	2.50	47.523	1.50	7	24.647
47×44.5	36	45.00	38.971	46.75	44.25	46.83	44.42	+0.3125	2.324	2.25	42.268	1.79	2.50	49.591	1.54	7	24.513
48×45.5	37	46.25	40.054	47.75	45.25	47.83	45.42	+0.1875	2.180	2.25	43.216	1.82	2.50	50.576	1.56	7	24.446
50×47.5	38	47.50	41.136	49.75	47.25	49.83	47.42	+0.5625	2.613	2.25	45.276	1.73	2.50	52.540	1.52	7	24.876
(52×49.5)	40	50.00	43.301	51.75	49.25	51.83	49.42	+0.3125	2.324	2.25	47.269	1.79	2.50	54.602	1.56	-	-

**Table 3 Dimensions for Involute Splines of Module (1.5)**  
(Clauses 6.2 to 6.10)

All dimensions in millimetres.

NOMINAL SIZE										INTERNAL SPLINE			EXTERNAL SPLINE				
										Pin Dia	Measurement Between pine	Deviation Factor	Pin Dia	Measurement Over Pins	Deviation Factor	Tooth Thickness Over z' Teeth	
d <sub>1</sub> × d <sub>2</sub>	Z	d <sub>0</sub>	D	d <sub>3</sub>	d	d Min	d Max	xm	l <sub>a</sub> = S <sub>a</sub>	d	M	f	d	M <sub>a</sub>	f <sub>a</sub>	Z'	Tooth thickness deviation factor 0.866
12×9	6	9.0	7.794	11.7	8.7	11.76	8.94	+0.675	3.136	2.75	6.180	1.77	5.50	2.173	1.02	2	7.216
15×12	8	12.0	10.392	14.7	11.7	14.76	11.94	+0.675	3.136	2.75	9.180	1.76	4.50	21.155	1.11	2	7.355
17×14	10	15.0	12.990	16.7	13.7	16.77	13.93	+0.175	2.558	2.75	10.985	2.67	3.25	2.0593	1.31	2	6.995
18×15	10	15.0	12.990	17.7	14.7	17.77	14.93	+0.675	3.136	2.75	12.181	1.76	4.00	23.127	1.18	-	-
20×17	12	18.0	15.588	19.7	16.7	19.77	16.93	+0.175	2.558	2.75	14.038	2.33	3.00	22.995	1.38	3	11.216
22×19	13	19.5	16.887	21.7	18.7	21.77	18.93	+0.425	2.847	2.75	16.014	1.91	3.25	25.382	1.32	3	11.535
25×22	15	22.5	19.486	24.7	21.7	24.77	21.93	+0.425	2.847	2.75	19.036	1.88	3.25	28.446	1.35	3	11.675
28×25	17	25.5	22.084	27.7	24.7	27.78	24.92	+0.425	2.847	2.75	22.053	1.86	3.25	31.498	1.37	4	15.896
30×27	18	27.0	23.383	29.7	26.7	29.78	26.92	+0.675	3.136	2.75	24.181	1.75	3.25	33.532	1.36	4	16.216
32×29	20	30.0	25.81	31.7	28.7	31.78	28.92	+0.175	2.558	2.75	26.111	1.99	3.00	35.078	1.48	4	15.855
35×32	22	33.0	28.579	34.7	31.7	34.78	31.92	+0.175	2.558	2.75	29.118	1.96	3.00	38.092	1.49	4	15.995
37×34	23	34.5	29.878	36.7	33.7	36.78	33.92	+0.425	2.847	2.75	31.087	1.83	3.00	39.939	1.46	5	20.396
38×35	24	36.0	31.177	37.7	34.7	37.78	34.92	+0.175	2.558	2.75	32.125	1.93	3.00	41.103	1.51	5	20.216
40×37	25	37.5	32.476	39.7	36.7	39.78	36.92	+0.425	2.847	2.75	34.094	1.82	3.00	42.961	1.48	5	20.535
42×39	26	39.0	33.775	41.7	38.7	41.78	38.92	+0.675	3.136	2.75	36.181	1.74	3.00	44.972	1.46	5	20.855
45×42	28	42.0	36.373	44.7	41.7	44.78	41.92	+0.675	3.136	2.75	39.181	1.74	3.00	47.988	1.47	6	25.076
47×44	30	45.0	38.971	46.7	43.7	46.78	43.92	+0.175	2.558	2.75	41.138	1.88	3.00	50.130	1.54	6	24.716
48×45	30	45.0	38.971	47.7	44.7	47.78	44.92	+0.675	3.136	2.75	42.181	1.74	3.00	51.003	1.48	6	25.216
50×47	32	48.0	41.569	49.7	46.7	49.78	46.92	+0.175	2.558	2.75	44.141	1.87	3.00	53.138	1.55	6	24.855
(52×49)	33	49.5	42.868	51.7	48.7	51.78	48.92	+0.425	2.847	2.75	46.115	1.80	3.00	55.026	1.52	6	25.175
55×52	35	52.5	45.466	54.7	51.7	54.79	51.91	+0.425	2.847	2.75	49.119	1.79	3.00	58.038	1.53	7	29.396
(58×55)	37	55.5	48.064	57.7	54.7	57.79	54.91	+0.425	2.847	2.75	52.122	1.79	3.00	61.049	1.54	7	29.535
60×57	38	57.0	49.363	59.7	56.7	59.79	56.91	+0.675	3.136	2.75	54.181	1.75	3.00	63.047	1.052	7	29.855
(62×59)	40	60.0	51.962	61.7	58.7	61.79	58.91	+0.175	2.558	2.75	56.150	1.84	3.00	65.160	1.058	7	29.495

**Table 4 Dimensions for Involute Splines of Module 2***(Clauses 6.2 to 6.10)*

All dimensions in millimetres.

NOMINAL SIZE										INTERNAL SPLINE			EXTERNAL SPLINE				
										Pin Dia	Measurement Between pins	Deviation Factor	Pin Dia	Measurement Over Pins	Deviation Factor	Tooth Thickness Over z' Teeth	
																	Tooth thickness deviation factor 0.866
$d_1 \times d_2$	Z	$d_0$	D	$d_3$	d	d Min	d Max	xm	$l_a = s_a$	d	M	f	d	$M_a$	$f_a$	Z'	
15×11	6	12	10.392	14.6	10.6	14.68	10.92	+0.4	3.603	3.5	7.629	2.42	5.5	22.212	1.11	2	9.121
17×13	7	14	12.124	16.6	12.6	16.68	12.92	+0.4	3.603	3.5	9.324	2.19	5.0	22.695	1.13	2	9.214
18×14	7	14	12.124	17.6	13.6	17.68	13.92	+0.9	4.181	3.5	10.379	1.61	6.0	25.588	1.06	2	9.714
20×16	8	16	13.856	19.6	15.6	19.68	15.92	+0.9	4.181	3.5	12.736	1.66	6.0	28.206	1.11	2	9.807
22×18	9	18	15.588	21.6	17.6	21.68	17.92	+0.9	4.181	3.5	14.460	1.64	5.5	28.790	1.13	-	-
25×21	11	22	19.053	24.6	20.6	24.68	20.92	+0.4	3.603	3.5	17.478	1.96	4.5	29.898	1.28	-	-
28×24	12	24	20.785	27.6	23.6	27.68	23.92	+0.9	4.181	3.5	20.738	1.68	5.0	34.161	1.23	3	15.621
30×26	14	28	24.249	29.6	25.6	29.69	25.91	-0.1	3.026	3.5	22.484	2.41	4.0	34.144	1.46	3	14.807
32×28	14	28	24.249	31.6	27.6	31.69	27.91	+0.9	4.181	3.5	24.738	1.69	4.5	37.016	1.30	3	15.807
35×31	16	32	27.713	34.6	30.6	34.69	30.91	+0.4	3.603	3.5	27.711	1.88	4.0	39.000	1.42	3	15.493
37×33	17	34	29.445	36.6	32.6	36.69	32.91	+0.4	3.603	3.5	29.571	1.86	4.0	40.857	1.42	4	21.028
38×34	18	36	31.177	37.6	33.6	37.69	33.91	-0.1	3.026	3.5	30.566	2.15	4.0	42.181	1.50	3	15.179
40×36	18	36	31.177	39.6	35.6	39.69	35.91	+0.9	4.181	3.5	32.739	1.70	4.5	45.137	1.35	4	21.621
42×38	20	40	34.641	41.6	37.6	41.69	37.91	-0.1	3.026	3.5	34.589	2.08	4.0	46.195	1.52	4	20.807



45×41 47×43	21 22	42 44	36.373 38.105	44.6 46.6	40.6 42.6	44.69 46.69	40.91 42.91	+0.4 +0.4	3.603 3.603	3.5 3.5	37.604 39.720	1.84 1.84	4.0 4.0	48.938 51.074	1.46 1.47	4 4	21.400 21.493
48×44 50×46	22 24	44 48	38.105 41.569	47.6 49.6	43.6 45.6	47.69 49.69	43.91 45.91	+0.9 -0.1	4.181 3.026	3.5 3.5	40.740 42.621	1.7. 2.00	4.0 4.0	51.912 54.218	1.43 1.54	5 4	27.435 21.179
(52×48) 55×51	24 26	48 52	41.569 45.033	51.6 54.6	47.6 50.6	51.69 54.70	47.91 50.90	+0.9 +0.4	4.181 3.603	3.5 3.5	44.740 47.724	1.71 1.82	4.0 4.0	55.939 59.109	1.44 1.50	5 5	27.621 27.307
(58×54) 60×56	28 28	56 56	48.497 48.497	57.8 59.6	53.6 55.6	57.70 59.70	53.90 55.90	-0.1 +0.9	3.026 4.181	3.5 3.5	50.642 32.740	1.95 1.71	4.0 4.0	62.235 63.984	1.56 1.47	5 6	26.933 33.435
(62×58) 65×61	30 31	60 62	51.962 53.694	61.6 64.6	54.6 60.6	61.70 64.70	57.90 60.90	-0.1 +0.4	3.026 3.603	3.5 3.5	54.650 57.648	1.93 1.80	4.0 4.0	66.242 69.058	1.57 1.53	5 6	27.179 33.214
(68×64) 70×66	32 34	64 68	55.426 58.890	67.6 69.6	63.6 65.6	67.70 69.70	63.90 65.90	+0.9 -0.1	4.181 3.026	3.5 3.5	60.740 62.663	1.71 1.90	4.0 4.0	72.021 74.253	1.49 1.59	6 6	33.807 32.993
(72×68) 75×71	34 36	68 72	58.890 62.354	71.6 74.6	67.6 70.6	71.70 74.70	67.90 70.90	+0.9 +0.4	4.181 3.603	3.5 3.5	64.740 67.726	1.71 1.79	4.0 4.0	76035 79.166	1.50 1.55	7 7	39.435 39.121
(78×74) 80×76	38 38	76 76	65.818 65.818	77.6 79.6	73.6 75.6	77.70 79.70	73.90 75.90	-0.1 +0.9	3.026 4.181	3.5 3.5	70.672 72.740	1.88 1.72	4.0 4.0	82.263 84.063	1.60 1.52	7 7	38.807 39.807
(82×78)	40	80	69.282	81.6	77.6	81.70	77.90	-0.1	3.026	3.5	74.676	1.87	4.0	86.267	1.61	7	38.993

Table 5 Dimensions for Involute Splines of Module 2.5

(Clauses 6.2 to 6.10)

All dimensions in millimetres.

NOMINAL SIZE										INTERNAL SPLINE			EXTERNAL SPLINE				
										Pin Dia	Measurement Between pins	Deviation Factor	Pin Dia	Measurement Over Pins	Deviation Factor	Tooth Thickness Over z' Teeth	
																	0.866
d <sub>1</sub> × d <sub>2</sub>	Z	d <sub>0</sub>	D	d <sub>3</sub>	d	d Min	d Max	xm	l <sub>a</sub> = s <sub>a</sub>	d	M	f	d	M <sub>a</sub>	f <sub>a</sub>	Z'	
20×15	6	15.0	12.990	19.5	14.5	19.58	14.92	+1.125	5.226	4.5	10.552	1.71	9.0	33.258	1.03	2	12.026
22×17	7	17.5	15.155	21.5	16.5	21.38	16.92	+0.875	4.937	4.5	12.105	1.85	7.0	30.558	1.08	2	11.892
25×20	8	20.0	17.321	24.5	19.5	24.58	19.92	+1.125	5.226	4.5	15.552	1.72	7.0	34.113	1.13	2	12.259
28×23	10	25.0	21.651	27.5	22.5	27.58	22.92	+0.125	4.071	4.25	19.116	2.30	5.0	33.006	1.37	2	11.491
30×25	10	25.0	21.651	29.5	24.5	29.58	24.92	+1.125	5.226	4.5	20.552	1.72	6.5	38.151	1.19	3	19.293
32×27	11	27.5	23.816	31.5	26.5	31.59	26.91	+0.875	4.937	4.5	22.265	1.81	6.0	38.835	1.23	3	19.160
35×30	12	30.0	25.981	34.5	29.5	34.59	29.91	+1.125	5.226	4.5	25.552	1.72	6.0	42.093	1.25	3	19.526
37×32	13	32.5	28.146	36.5	31.5	36.59	31.91	+0.875	4.937	4.5	27.308	1.80	5.5	42.764	1.30	3	19.392
38×33	14	35.0	30.311	37.5	32.5	37.59	32.91	+0.125	4.071	4.5	28.316	2.26	5.0	43.093	1.43	3	18.759
40×35	14	35.0	30.311	39.5	34.5	39.53	34.91	+1.125	5.226	4.5	30.552	1.72	6.0	47.204	1.28	3	19.759
42×37	15	37.5	32.476	41.5	36.5	41.59	36.91	+0.875	4.937	4.5	32.340	1.79	5.5	47.881	1.33	3	19.625
45×40	16	40.0	34.641	44.5	39.5	44.59	39.91	+1.125	5.226	4.5	35.552	1.73	5.5	51.035	1.33	4	26.793
47×42	17	42.5	36.806	46.5	41.5	46.59	41.91	+0.875	4.937	4.5	37.365	1.78	5.5	52.974	1.36	4	26.660
48×43	18	45.0	38.971	47.5	42.5	47.59	42.91	+0.125	4.071	4.5	38.387	2.07	5.0	53.156	1.47	4	26.026
50×45	18	45.0	38.971	49.5	44.5	49.59	44.91	+1.125	5.226	4.5	40.552	1.73	5.5	56.100	1.36	4	27.026
(52×47)	19	47.5	41.136	51.5	46.5	51.59	46.91	+0.875	4.937	4.5	42.384	1.78	5.5	58.052	1.38	4	26.892
55×50	20	50.0	43.301	54.5	49.5	54.59	49.91	+1.125	5.226	4.5	45.552	1.73	5.5	61.157	1.38	4	27.259
(58×53)	22	55.0	47.631	57.5	52.5	57.60	52.90	+0.125	4.071	4.5	48.424	1.99	5.0	63.198	1.51	4	26.491
60×65	22	55.0	47.631	59.5	54.5	59.60	54.90	+1.125	5.226	4.5	50.552	1.73	5.5	66.206	1.40	5	34.239
(62×57)	23	57.0	49.796	61.5	56.5	61.60	56.90	+0.875	4.937	4.5	52.413	1.77	5.0	66.846	1.45	5	34.160
65×60	24	60.0	51.962	64.5	59.5	64.60	59.90	+1.125	5.226	4.5	55.552	1.73	5.0	69.924	1.44	5	34.526
(68×63)	26	65.0	56.292	67.5	62.5	67.60	62.90	+0.125	4.071	4.5	58.448	1.94	5.0	73.229	1.53	5	33.759
70×65	26	65.0	56.292	69.5	64.5	69.60	64.90	+1.125	5.226	4.5	60.552	1.73	5.0	74.954	1.46	5	34.759
(72×67)	27	67.5	58.457	71.5	66.5	71.60	66.90	+0.875	4.937	4.5	62.434	1.77	5.0	76.920	1.48	5	34.625
75×70	28	70.0	60.622	74.5	69.5	74.60	69.90	+1.125	5.226	4.5	65.552	1.73	5.0	79.981	1.47	6	41.793
(78×73)	30	75.0	64.952	77.5	72.5	77.60	72.90	+0.125	4.071	4.5	68.464	1.90	5.0	83.253	1.55	6	41.026
80×75	30	75.0	64.952	79.5	74.5	79.60	74.90	+1.125	5.226	4.5	70.552	1.73	5.0	85.004	1.48	6	42.026
(82×77)	31	77.5	67.117	81.5	76.5	81.60	76.90	+0.875	4.937	4.5	72.449	1.76	5.0	86.978	1.50	6	41.892
85×80	32	80.0	69.282	84.5	79.5	84.60	79.90	+1.125	5.226	4.5	75.552	1.73	5.0	90.026	1.49	6	42.259
(88×83)	34	85.0	73.612	87.5	82.5	87.60	82.90	+0.125	4.071	4.5	78.476	1.88	5.0	93.273	1.57	6	41.491
90×85	34	85.0	73.612	89.5	84.5	89.60	84.90	+1.125	5.226	4.5	80.552	1.73	5.0	95.045	1.50	7	49.293
(92×87)	35	87.5	75.777	91.5	86.5	91.60	86.90	+0.875	4.937	4.5	82.461	1.76	5.0	97.024	1.52	7	49.160
95×90	36	90.0	77.942	94.5	89.5	94.60	89.90	+1.125	5.226	4.5	85.552	1.73	5.0	100.063	1.51	7	49.526
(98×93)	38	95.0	82.272	97.5	92.5	97.60	92.90	+0.125	4.071	4.5	88.485	1.86	5.0	103.288	1.58	7	48.759
100×95	38	95.0	82.272	99.5	94.5	99.60	94.90	+1.125	5.226	4.5	90.552	1.73	5.0	105.079	1.52	7	49.759
(105×100)	40	100.0	86.603	104.5	99.5	104.60	99.90	+1.125	5.226	4.5	95.552	1.73	5.0	110.094	1.53	8	56.793

Table 6 Dimensions for Involute Splines of Module 3

(Clauses 6.2 to 6.10)

All dimensions in millimetres.

NOMINAL SIZE										INTERNAL SPLINE			EXTERNAL SPLINE				
--------------	--	--	--	--	--	--	--	--	--	-----------------	--	--	-----------------	--	--	--	--

d <sub>1</sub> × d <sub>2</sub>	Z	d <sub>0</sub>	D	d <sub>3</sub>	d	d Min	d Max	Xm	I <sub>a</sub> = S <sub>a</sub>	d	Measurement Between pins M	Deviation Factor F	Pin Dia	Measurement Over Pins M <sub>a</sub>	Deviation Factor f <sub>a</sub>	Tooth Thickness Over z' Teeth	
																Z'	Tooth thickness deviation factor 0.866
22×16	6	18	15.588	21.4	15.4	21.48	15.92	+0.35	5.117	5.00	11.694	2.42	7	30.099	1.17	2	13.431
25×19	7	21	18.187	24.4	18.4	24.48	18.92	+0.35	5.177	5.00	14.235	2.18	7	32.544	1.17	2	13.571
28×22	8	24	20.785	27.4	21.4	27.48	21.92	+0.35	5.117	5.25	16.835	2.56	7	36.289	1.23	2	13.710
30×24	8	24	20.785	29.4	23.4	29.48	23.92	+1.35	6.271	5.25	19.105	1.66	8	40.013	1.14	2	14.710
32×26	9	27	23.383	31.4	25.4	31.49	25.91	+0.85	5.694	5.25	20.686	1.85	7	39.577	1.21	2	14.350
35×29	10	30	25.981	34.4	28.4	34.49	28.91	+0.85	5.694	5.25	24.089	1.86	7	43.158	1.25	2	14.490
39×31	11	33	28.579	36.4	30.4	36.49	30.91	+0.35	5.117	5.25	25.627	2.14	6	42.581	1.35	2	14.129
38×32	11	33	28.579	37.4	31.4	37.49	31.91	+0.85	5.694	5.25	26.762	1.83	7	45.828	1.25	3	22.791
40×34	12	36	31.177	39.4	33.4	39.49	33.91	+0.35	5.117	5.25	28.964	2.10	6	45.989	1.38	3	22.431
42×36	12	36	31.177	41.4	35.4	41.49	35.91	+1.35	6.271	5.25	31.107	1.68	7	50.023	1.26	3	23.431
45×39	14	42	36.373	44.4	38.4	44.49	38.91	-0.15	4.539	5.25	33.726	2.41	6	51.216	1.46	3	22.210
47×41	14	42	36.373	46.4	40.4	46.49	40.91	+0.85	5.694	5.25	36.096	1.82	6	52.848	1.37	3	23.210
48×42	14	42	36.373	47.4	41.4	47.49	41.91	+1.35	6.271	5.25	37.108	1.69	7	56.148	1.29	3	23.710
50×44	15	45	38.971	49.4	43.4	49.49	43.91	+0.85	5.694	5.25	38.855	1.80	6	55.606	1.38	3	23.350
(52×46)	16	48	41.569	51.4	45.4	51.49	45.91	+0.35	5.117	5.25	41.010	1.97	6	58.088	1.44	3	22.990
(55×49)	17	51	44.167	54.4	48.4	54.50	48.90	+0.35	5.117	5.25	43.807	1.95	6	60.873	1.44	3	23.129
(58×52)	18	54	46.765	57.4	51.4	57.50	51.90	+0.35	5.117	5.25	47.024	1.94	6	64.125	1.46	4	31.431
60×54	18	54	46.765	59.4	53.4	59.50	53.90	+1.35	6.271	5.25	49.109	1.70	7	68.343	1.34	4	32.431
(62×56)	19	57	49.363	61.4	55.4	61.50	55.90	+0.85	5.694	5.25	50.908	1.79	6	67.767	1.43	4	32.071
65×59	20	60	51.962	64.4	58.4	64.50	58.90	+0.85	5.694	5.25	54.101	1.79	6	70.999	1.44	4	32.210
(68×62)	21	63	54.560	67.4	61.4	67.50	61.90	+0.85	5.694	5.25	56.928	1.78	6	73.827	1.45	4	32.350
70×64	22	66	57.158	69.4	63.4	69.50	63.90	+0.35	5.117	5.25	59.042	1.89	6	76.183	1.49	4	31.990
(72×66)	22	66	57.158	71.4	65.4	71.50	65.90	+1.35	6.271	5.25	61.109	1.70	6	77.868	1.43	5	41.152
75×69	24	72	62.354	74.4	68.4	74.50	68.90	-0.15	4.539	5.25	63.932	2.00	6	81.326	1.54	4	31.769
(78×72)	24	72	62.354	77.4	71.4	77.50	71.90	+1.35	6.271	5.25	67.110	1.71	6	83.909	1.44	5	41.431
80×74	25	75	64.952	79.4	73.4	79.50	73.90	+0.85	5.694	5.25	68.957	1.78	6	85.923	1.48	5	41.071
(82×76)	26	78	67.550	81.4	75.4	81.50	75.90	+0.35	5.117	5.25	71.054	1.86	6	88.227	1.52	5	40.710
85×79	27	81	70.148	84.4	78.4	84.50	78.90	+0.35	5.117	5.25	73.923	1.85	6	91.092	1.52	5	40.850
(88×82)	28	84	72.746	87.4	81.4	87.50	81.90	+0.35	5.117	5.25	77.059	1.85	6	94.254	1.53	5	40.990
90×84	28	84	72.746	89.4	83.4	89.50	83.90	+1.35	6.271	5.25	79.110	1.71	6	95.977	1.47	6	50.152
(92×86)	29	87	75.344	91.4	85.4	91.50	85.90	+0.85	5.694	5.25	80.978	1.77	6	97.995	1.49	6	49.791
95×89	30	90	77.942	94.4	88.4	94.50	88.90	+0.85	5.694	5.25	84.105	1.77	6	101.141	1.51	6	49.931
(98×92)	31	93	80.540	97.4	91.4	97.50	91.90	+0.85	5.694	5.25	86.987	1.77	6	104.025	1.51	6	50.071
100×94	32	96	83.138	99.4	93.4	99.50	93.90	+0.35	5.117	5.25	89.066	1.83	6	106.275	1.55	6	49.710
105×99	34	102	88.335	104.4	98.4	104.51	98.90	-0.15	4.539	5.25	93.994	1.90	6	111.380	1.59	6	49.490
110×101	35	105	90.933	109.4	103.4	109.51	103.89	+0.85	5.694	5.25	99.001	1.76	6	116.076	1.53	7	58.791
120×114	38	114	98.727	119.4	113.4	119.51	113.89	+1.35	6.271	5.25	109.111	1.72	6	129.095	1.52	7	59.710
130×124	42	126	109.119	129.4	123.4	129.51	123.89	+0.35	5.117	5.25	119.078	1.81	6	136.329	1.58	8	67.431
140×134	45	135	116.913	139.4	133.4	139.51	133.89	+0.85	5.694	5.25	129.026	1.76	6	146.168	1.57	8	68.350
150×144	48	144	124.708	149.4	143.4	149.51	143.89	+1.35	6.271	5.25	139.111	1.72	6	156.172	1.55	9	77.431

**Table 7 Dimensions for Involute Splines of Module 4**

(Clauses 6.2 to 6.10)

All dimensions in millimetres.

NOMINAL SIZE										INTERNAL SPLINE			EXTERNAL SPLINE				
										Pin Dia	Measurement Between pins	Deviation Factor	Pin Dia	Measurement Over Pins	Deviation Factor	Tooth Thickness Over z' Teeth	
																	Tooth thickness deviation factor 0.866
$d_1 \times d_2$	Z	$d_0$	D	$d_3$	D	d Min	d Max	xm	$l_a = S_a$	d	M	f	d	$M_a$	$f_a$	Z'	
32×23	6	24	20.785	31.2	23.2	31.28	23.92	+1.8	8.362	7	17.470	1.64	15	54.521	1.02	2	19.241
35×27	7	28	24.249	34.2	26.2	34.29	26.91	+1.3	7.784	7	19.778	1.80	11	48.316	1.09	2	18.928
37×29	8	32	27.713	36.2	28.2	36.29	28.91	+0.3	6.630	6.75	22.935	2.42	9	47.335	1.25	2	18.114
38×30	8	32	27.713	37.2	29.2	37.29	29.91	+0.8	7.207	7	23.337	2.13	10	50.447	1.19	2	18.614
40×32	8	32	27.713	39.2	31.2	39.29	31.91	+1.8	8.362	7	25.473	1.66	12	56.413	1.11	2	19.614
42×34	9	36	31.177	41.2	33.2	41.29	33.91	+0.8	7.207	7	26.837	2.03	9	51.497	1.23	2	18.800
45×37	10	40	34.641	44.2	36.2	44.29	36.91	+0.3	6.630	7	30.113	2.41	8	52.967	1.36	2	18.486
47×39	10	40	34.641	46.2	38.2	46.29	38.91	+1.3	7.784	7	32.472	1.81	10	59.393	1.21	2	19.486
48×40	10	40	34.641	47.2	39.2	47.29	39.91	+1.8	8.362	7	33.475	1.67	10	60.090	1.20	3	30.869
50×42	11	44	38.105	49.2	41.2	49.29	41.91	+0.8	7.207	7	34.955	1.96	9	59.979	1.28	3	30.055
(52×44)	11	44	38.105	51.2	43.2	51.29	43.91	+1.8	8.362	7	37.023	1.66	10	63.660	1.21	3	31.055
55×47	12	48	41.569	54.2	46.2	54.29	46.91	+1.3	7.784	7	40.474	1.79	9	65.139	1.29	3	30.741
(58×50)	13	52	45.033	57.2	49.2	57.30	49.90	+0.8	7.207	7	43.037	1.91	8	65.470	1.37	3	30.428
60×52	14	56	48.497	59.2	51.2	59.30	51.90	-0.2	6.052	7	44.967	2.41	8	68.288	1.46	3	29.614
(62×54)	14	56	48.497	61.2	53.2	61.30	53.90	+0.8	7.207	7	47.411	1.91	8	69.932	1.39	3	30.614
65×67	15	60	51.962	64.2	56.2	64.30	56.90	+0.3	6.630	7	49.965	2.05	8	72.791	1.43	3	30.300
(68×60)	16	64	55.426	67.2	59.2	67.30	59.90	-0.2	6.052	7	53.066	2.25	8	76.329	1.48	3	29.986
70×62	16	64	55.426	69.2	61.2	69.30	61.90	+0.8	7.207	7	55.421	1.88	8	78.001	1.42	3	30.986
(72×64)	16	64	55.426	71.2	63.2	71.30	63.90	+1.8	8.362	7	57.478	1.69	9	82.163	1.33	4	42.896
75×67	17	68	58.890	74.2	66.2	74.30	66.90	+1.3	7.784	7	60.189	1.77	9	85.115	1.35	4	42.555
(78×70)	18	72	62.354	77.2	69.2	77.30	69.90	+0.8	7.207	7	63.429	1.86	8	86.058	1.44	4	42.241
80×72	18	72	62.354	79.2	71.2	79.30	71.90	+1.8	8.362	7	65.478	1.70	9	90.273	1.35	4	43.241
(82×74)	19	76	65.818	81.2	73.2	81.30	73.90	+0.8	7.207	7	67.178	1.85	8	89.803	1.44	4	42.428
85×77	20	80	69.282	84.2	76.2	84.30	76.90	+0.3	6.630	7	70.341	1.95	8	93.257	1.49	4	42.114
(88×80)	20	80	69.282	87.2	79.2	87.30	79.90	+1.8	8.362	7	73.479	1.70	9	98.368	1.37	4	43.614
90×82	21	84	72.746	89.2	81.2	89.30	81.90	+0.8	7.207	7	75.207	1.84	8	97.877	1.46	4	42.800
(92×84)	22	88	76.210	91.2	83.2	91.30	83.90	-0.2	6.052	7	77.215	2.04	8	100.415	1.53	4	41.986
95×87	22	88	76.210	94.2	86.2	94.30	86.90	+1.3	7.784	7	80.478	1.76	8	102.993	1.45	4	43.486
(98×90)	23	92	79.674	97.2	89.2	97.30	89.90	+0.8	7.207	7	83.231	1.83	8	105.939	1.48	5	54.055
100×92	24	96	83.138	99.2	91.2	99.30	91.90	-0.2	6.052	7	85.243	2.00	8	108.435	1.54	4	42.359
105×97	25	100	86.603	104.2	96.2	104.30	96.90	+0.3	6.630	7	90.181	1.89	8	113.123	1.52	5	53.928
110×102	26	104	90.067	109.2	101.2	109.31	101.90	+0.8	7.207	7	95.447	1.82	8	118.217	1.50	5	54.614
120×112	28	112	96.995	119.2	111.2	119.31	111.90	+1.8	8.362	7	105.480	1.71	8	127.969	1.47	6	66.869
130×122	31	124	107.387	129.2	121.2	129.31	121.90	+0.8	7.207	7	115.296	1.80	8	138.115	1.53	6	66.428
140×132	34	136	117.779	139.2	131.2	139.31	131.90	-0.2	6.052	7	125.325	1.90	8	148.507	1.59	6	65.986
150×142	36	144	124.708	149.2	141.2	149.31	141.90	+0.8	7.207	7	135.458	1.79	8	158.332	1.55	7	78.241

160×152	38	152	131.636	159.2	151.2	159.31	151.90	+1.8	8.362	7	145.481	1.72	8	168.127	1.52	7	79.614
170×162	41	164	142.028	169.2	161.2	169.31	161.90	+0.8	7.207	7	155.342	1.78	8	178.247	1.57	8	90.055

**Table 8 Dimensions for Involute Splines of Module 5**

(Clauses 6.2 to 6.10)

All dimensions in millimetres.

NOMINAL SIZE		INTERNAL SPLINE									EXTERNAL SPLINE						
		Pin Dia	Measurement Between pins	Deviation Factor	Pin Dia	Measurement Over Pins	Deviation Factor	Tooth Thickness Over z' Teeth									
d <sub>1</sub> × d <sub>2</sub>	Z	d <sub>0</sub>	D	d <sub>3</sub>	D	d Min	d Max	xm	l <sub>a</sub> = S <sub>a</sub>	d	M	f	D	M <sub>a</sub>	f <sub>a</sub>	Z'	Tooth thickness deviation factor 0.866
40×30	6	30	25.981	39	29	39.10	29.90	+2.25	10.452	9.0	21.103	1.71	18	66.516	1.03	2	24.052
42×32	7	35	30.318	41	31	41.10	31.90	+0.75	8.720	8.5	23.559	2.18	12	55.246	1.16	2	22.785
45×35	7	35	30.318	44	34	44.10	34.90	+2.25	10.452	9.0	25.223	1.67	16	66.185	1.04	2	24.285
47×37	8	40	34.641	46	36	46.10	36.90	+0.75	8.720	9.0	27.554	2.71	12	61.519	1.21	2	23.017
48×38	8	40	34.641	47	37	47.10	37.90	+1.25	9.297	9.0	28.922	2.13	12	62.214	1.20	2	23.517
50×40	8	40	34.641	49	39	49.10	39.90	+2.25	10.452	9.0	31.103	1.72	14	68.226	1.13	2	24.517
(52×42)	9	45	38.971	51	41	51.10	41.90	+0.75	8.720	9.0	32.028	2.41	11	63.404	1.25	2	23.250
55×45	9	45	38.971	54	44	54.10	44.90	+2.25	10.452	9.0	35.418	1.69	14	72.552	1.13	2	24.750
(58×48)	10	50	43.301	57	47	57.10	47.90	+1.25	9.297	9.0	38.968	2.01	12	72.502	1.24	2	23.983
60×50	10	50	43.301	59	49	59.10	49.90	+2.25	10.452	9.0	41.103	1.72	14	78.660	1.17	3	38.586
(62×52)	11	55	47.631	61	51	61.11	51.89	+0.75	8.720	9.0	42.254	2.19	11	73.752	1.30	2	23.716
65×55	11	55	47.631	64	54	64.11	54.89	+2.25	10.452	9.0	45.542	1.70	12	78.376	1.22	3	38.819
(68×58)	12	60	51.962	67	57	67.11	57.89	+1.25	9.297	9.0	48.996	1.95	11	80.236	1.31	3	38.052
70×60	12	60	51.962	69	59	69.11	59.89	+2.25	10.452	9.0	51.103	1.72	12	84.186	1.25	3	39.052
(72×62)	13	65	56.292	71	61	71.11	61.89	+0.75	8.720	9.0	52.398	2.08	10	81.440	1.38	3	37.785
75×65	14	70	60.622	74	64	74.11	64.89	-0.25	7.565	9.0	55.235	2.62	10	85.360	1.46	3	37.017
(78×68)	14	70	60.622	77	67	77.11	67.89	+1.25	9.297	9.0	59.014	1.91	11	90.386	1.34	3	38.517
80×70	14	70	60.622	79	69	79.11	69.89	+2.25	10.452	9.0	61.103	1.72	12	94.408	1.28	3	39.517
(82×72)	15	75	64.952	81	71	81.11	71.89	+0.75	8.720	9.0	62.489	2.01	10	91.603	1.41	3	38.250
85×75	16	80	69.282	84	74	84.11	74.89	-0.25	7.565	9.0	65.416	2.37	10	95.411	1.48	3	37.483
(88×78)	16	80	69.282	87	77	87.11	77.89	+1.25	9.297	9.0	69.027	1.88	10	97.909	1.41	3	38.983
90×80	16	80	69.282	89	79	89.11	79.89	+2.25	10.452	9.0	71.103	1.73	11	102.069	1.33	4	53.586
(92×82)	17	85	73.612	91	81	91.11	81.89	+0.75	8.720	9.0	72.574	1.96	10	101.731	1.43	3	38.716
95×85	18	90	77.942	94	84	94.11	84.89	-0.25	7.565	9.0	75.532	2.24	10	105.453	1.50	3	37.948
(98×88)	18	90	77.942	97	87	97.11	87.89	+1.25	9.297	9.0	79.036	1.86	10	107.987	1.43	4	53.052
100×90	18	90	77.942	99	89	99.11	89.89	+2.25	10.452	9.0	81.103	1.73	11	112.210	1.36	4	54.052
105×95	20	100	86.603	104	94	104.11	94.89	-0.25	7.565	9.0	85.613	2.15	10	115.488	1.52	4	52.017
110×100	21	105	90.933	109	99	109.12	99.89	-0.25	7.565	9.0	90.366	2.11	10	120.195	1.52	4	52.250
120×110	22	110	95.263	119	109	119.12	109.88	+2.25	10.452	9.0	101.104	1.73	10	129.781	1.43	5	68.586

130×120	24	120	103.923	129	119	129.12	119.88	+2.25	10.452	9.0	111.104	1.73	10	139.848	1.44	5	69.052
140×130	26	130	112.583	139	129	139.12	129.88	+2.25	10.452	9.0	121.104	1.73	10	149.908	1.46	5	69.517
150×140	28	140	121.244	149	139	149.12	139.88	+2.25	10.452	9.0	131.104	1.73	10	159.961	1.47	6	83.586
160×150	30	150	129.904	159	149	159.12	149.88	+2.25	10.452	9.0	141.104	1.73	10	170.009	1.48	6	84.052
170×160	32	160	138.564	169	159	169.12	159.88	+2.25	10.452	9.0	151.104	1.73	10	180.052	1.49	6	84.517
180×170	34	170	147.224	179	169	179.12	169.88	+2.25	10.452	9.0	161.104	1.73	10	190.091	1.50	7	98.586
190×180	36	180	155.885	189	179	189.12	179.88	+2.25	10.452	9.0	171.104	1.73	10	200.126	1.51	7	99.052
200×190	38	190	164.545	199	189	199.12	189.88	+2.25	10.452	9.0	181.104	1.73	10	210.158	1.52	7	99.517
210×200	40	200	173.205	209	199	209.12	199.88	+2.25	10.452	9.0	191.104	1.73	10	220.188	1.53	8	113.586
220×210	42	210	181.865	219	209	219.14	209.86	+2.25	10.452	9.0	201.104	1.73	10	230.216	1.54	8	114.052
240×230	46	230	199.186	239	229	239.14	229.86	+2.25	10.452	9.0	221.104	1.73	10	250.264	1.55	9	128.586
250×240	48	240	207.846	249	239	249.14	239.86	+2.25	10.452	9.0	231.104	1.73	10	260.286	1.55	9	129.052
260×250	50	250	216.506	259	249	258.14	249.86	+2.25	10.452	9.0	241.104	1.73	10	270.307	1.56	9	129.517
280×270	54	270	233.827	279	269	279.14	269.86	+2.25	10.452	9.0	261.104	1.73	10	290.344	1.57	10	144.052

**Table 9 Dimensions for Involute Splines of Module 6**  
(Clauses 6.2 to 6.10)

All dimensions in millimetres.

NOMINAL SIZE										INTERNAL SPLINE			EXTERNAL SPLINE						
										Pin Dia	Measurement Between pine	Deviation Factor	Pin Dia	Measurement Over Pins	Deviation Factor	Tooth Thickness Over z' Teeth			
																		Tooth thickness deviation factor 0.866	
d <sub>1</sub> × d <sub>2</sub>	Z	d <sub>0</sub>	D	d <sub>3</sub>	D	d Min	d Max	xm	l <sub>a</sub> = S <sub>a</sub>	d	M	f	d	M <sub>a</sub>	f <sub>a</sub>	Z'			
48×36	6	36	31.177	46.8	34.8	46.90	35.90	+2.7	12.542	10.5	26.204	1.64	22	80.692	1.02	2	28.862		
50×38	7	42	36.373	48.8	36.8	48.90	37.90	+0.7	10.233	10.5	28.471	2.18	14	65.089	1.17	2	27.141		
(52×40)	7	42	36.373	50.8	38.8	50.90	39.90	+1.7	11.388	10.5	29.136	1.89	16	71.023	1.10	2	28.414		
55×43	8	48	41.569	53.8	41.8	53.90	42.90	+0.2	9.653	10.5	34.169	2.56	12	66.901	1.33	2	26.921		
(58×46)	8	48	41.569	56.8	44.8	56.90	45.90	+1.7	11.388	10.5	36.165	1.91	16	78.701	1.16	2	28.421		
60×48	8	48	41.569	58.8	46.8	58.90	47.90	+2.7	12.542	10.5	38.209	1.66	18	84.619	1.11	2	29.421		
(62×50)	9	54	46.765	60.8	48.8	60.91	49.89	+0.7	10.233	10.5	39.007	2.32	14	77.745	1.23	2	27.700		
65×53	9	54	46.765	63.8	51.8	63.91	52.89	+2.2	11.967	10.5	42.406	1.73	16	84.551	1.15	2	29.200		
(68×56)	10	60	51.962	66.8	54.8	66.91	55.89	+0.7	10.233	10.5	45.840	2.24	14	84.862	1.27	2	27.979		
70×58	10	60	51.962	68.8	56.8	68.91	57.89	+1.7	11.388	10.5	48.179	1.86	14	86.315	1.25	2	28.979		
(72×60)	10	60	51.962	70.8	58.8	70.91	59.89	+2.7	12.542	10.5	50.212	1.67	16	92.508	1.18	3	46.304		
75×63	11	66	57.158	73.8	61.8	73.91	62.89	+1.2	10.810	10.5	52.433	1.96	14	90.930	1.27	3	45.083		
(78×66)	12	72	62.354	76.8	64.8	76.91	65.89	-0.3	9.078	10.5	55.200	2.75	12	90.355	1.43	2	27.538		
80×68	12	72	62.354	78.8	66.8	78.91	67.89	+0.7	10.233	10.5	57.928	2.10	12	91.978	1.38	3	44.862		

(82×70)	12	72	62.354	80.8	68.8	80.91	69.89	+1.7	11.388	10.5	60.187	1.84	14	98.580	1.28	3	45.862
85×73	13	78	67.550	83.8	71.8	83.91	72.89	+0.2	9.653	10.5	62.185	2.23	12	96.601	1.41	3	44.641
(88×76)	13	78	67.550	86.8	74.8	86.91	75.89	+1.7	11.388	10.5	65.631	1.82	14	104.032	1.29	3	46.141
90×78	14	84	72.746	88.8	76.8	88.91	77.89	-0.3	9.078	10.5	67.451	2.41	12	102.432	1.46	3	44.421
(92×80)	14	84	72.746	90.8	78.8	90.91	79.89	+0.7	10.233	10.5	69.982	2.02	12	104.088	1.41	3	45.421
95×83	14	84	72.746	93.8	81.8	93.91	82.89	+2.2	11.967	10.5	73.233	1.75	14	111.550	1.30	3	46.921
(98×86)	15	90	77.942	96.8	84.8	96.91	85.89	+0.7	10.233	10.5	75.529	1.99	12	109.597	1.42	3	45.700
100×88	15	90	77.942	98.8	86.8	98.91	87.89	+1.7	11.388	10.5	77.709	1.80	12	111.211	1.38	3	46.700
105×93	16	96	83.138	103.8	91.8	103.91	92.89	+1.2	10.810	10.5	83.132	1.88	12	117.001	1.42	3	46.479
110×98	17	102	88.335	108.8	96.8	108.92	97.88	+0.7	10.233	10.5	87.614	1.95	12	121.745	1.44	3	46.259
120×108	18	108	93.531	118.8	106.8	118.92	107.88	+2.7	12.542	10.5	98.217	1.70	14	136.686	1.34	4	64.862
130×118	20	120	103.923	128.8	116.8	128.92	117.88	+1.7	11.388	10.5	108.230	1.79	12	141.998	1.44	4	64.421
140×128	22	132	114.315	138.8	126.8	138.92	127.88	+0.7	10.233	10.5	118.085	1.89	12	152.367	1.49	4	63.979
150×138	24	144	124.708	148.8	136.8	148.92	137.88	-0.3	9.078	10.5	127.864	2.00	12	162.653	1.54	4	63.538
160×148	25	150	129.904	158.8	146.8	158.92	147.88	+1.7	11.388	10.5	137.914	1.78	12	171.846	1.48	5	82.141
170×158	27	162	140.296	168.8	156.8	168.92	157.88	+0.7	10.233	10.5	147.845	1.85	12	182.184	1.52	5	81.700
180×168	28	168	145.492	178.8	166.8	178.92	167.88	+2.7	12.542	10.5	158.220	1.71	12	191.953	1.47	6	100.304
190×178	30	180	155.885	188.8	176.8	188.92	177.88	+1.7	11.388	10.5	168.210	1.77	12	202.282	1.51	6	99.862
200×188	32	192	106.277	198.8	186.8	198.92	187.88	+0.7	10.233	10.5	178.133	1.83	12	212.550	1.55	6	99.421
210×198	34	204	176.669	208.8	196.8	208.94	197.86	-0.3	9.078	10.5	187.988	1.90	12	222.760	1.59	6	98.979
220×208	35	210	181.865	218.8	206.8	218.94	207.86	+1.7	11.388	10.5	198.002	1.76	12	232.152	1.53	7	117.583
240×228	38	228	197.454	238.8	226.8	238.94	227.86	+2.7	12.542	10.5	218.221	1.72	12	252.190	1.52	7	119.421
250×238	40	240	207.840	248.8	236.8	218.94	237.86	+1.7	11.388	10.5	228.214	1.76	12	262.447	1.55	7	118.979
260×248	42	252	218.238	258.8	246.8	258.94	247.86	+0.7	10.233	10.5	238.156	1.81	12	272.658	1.58	8	134.862
280×268	45	270	233.827	278.8	266.8	278.94	267.86	+1.7	11.388	10.5	258.052	1.76	12	292.335	1.57	8	136.700

**Table 10 Dimensions for Involute Splines of Module 8**

(Clauses 6.2 to 6.10)

All dimensions in millimetres.

NOMINAL SIZE	INTERNAL SPLINE									EXTERNAL SPLINE							
	Pin Dia	Measurement Between pine	Deviation Factor	Pin Dia	Measurement Over Pins	Deviation Factor	Tooth Thickness Over z' Teeth										
$d_1 \times d_2$	Z	$d_0$	D	$d_3$	D	d Min	d Max	xm	$l_a = s_a$	d	M	f	d	$M_a$	$f_a$	Z'	Tooth thickness deviation factor 0.866
60×44	6	48	41.569	58.4	42.4	58.50	43.90	+1.6	14.414	14	30.516	2.42	22	88.848	1.11	2	36.483
65×49	7	56	48.497	63.4	47.4	63.51	48.89	+0.1	12.686	13	36.925	2.63	16	79.195	1.27	2	35.355
70×54	7	56	48.497	68.4	52.4	68.51	53.89	+2.6	15.569	14	39.557	1.80	22	99.632	1.09	2	37.855
75×59	8	64	55.426	73.4	57.4	73.51	58.89	+1.1	13.841	14	45.371	2.42	18	95.390	1.24	2	36.728
80×64	8	64	55.426	78.4	62.4	78.51	63.89	+3.6	16.723	14	50.945	1.66	22	108.241	1.13	2	39.228

85×69	9	72	62.354	83.4	67.4	83.51	68.89	+2.1	14.996	14	54.803	1.89	20	108.481	1.18	2	38.100
90×74	10	80	69.282	88.4	72.4	88.51	73.89	+0.6	13.259	14	60.226	2.41	16	105.933	1.36	2	36.927
95×79	10	80	69.282	93.4	77.4	93.51	78.89	+3.1	16.151	14	65.966	1.73	20	119.486	1.21	3	61.238
100×84	11	88	76.210	98.4	82.4	98.51	83.89	+1.6	14.414	14	69.911	1.96	18	119.594	1.28	2	38.345
105×89	12	96	83.138	103.4	87.4	103.51	88.89	+0.1	12.686	14	75.080	2.41	16	121.294	1.41	2	37.217
110×94	12	96	83.138	108.4	92.4	108.51	93.89	+2.6	15.569	14	80.948	1.76	18	130.279	1.29	3	61.483
120×104	14	112	96.995	118.4	102.4	118.51	103.89	-0.4	12.104	14	89.935	2.41	16	136.575	1.46	3	59.228
130×114	15	120	103.923	128.4	112.4	128.51	113.89	+0.6	13.259	14	99.929	2.05	16	145.582	1.43	3	60.600
140×124	16	128	110.851	138.4	122.4	138.52	123.89	+1.6	14.414	14	110.843	1.88	16	156.001	1.42	3	61.972
150×134	17	136	117.779	148.4	132.4	148.51	133.89	+2.6	15.569	14	120.378	1.77	16	170.231	1.35	4	85.110
160×144	18	144	124.708	158.4	142.4	158.51	143.89	+3.6	16.723	14	130.956	1.70	16	180.546	1.35	4	86.483
170×154	20	160	138.564	168.4	152.4	168.51	153.89	+0.6	13.259	14	140.681	1.95	16	186.514	1.49	4	84.228
180×164	21	168	145.492	178.4	162.4	178.51	163.89	+1.6	14.414	14	150.414	1.84	16	195.753	1.46	4	85.600
190×174	22	176	152.420	188.4	172.4	188.51	173.89	+2.6	15.569	14	160.957	1.76	16	205.987	1.45	4	86.972
200×184	24	192	166.277	198.4	182.4	198.51	183.89	-0.4	12.104	14	170.486	2.00	16	216.870	1.54	4	84.717
210×194	25	200	173.205	208.4	192.4	208.52	193.89	+0.6	13.259	14	180.363	1.89	16	226.246	1.52	5	107.855
220×204	26	208	180.133	218.4	202.4	218.54	203.86	+1.6	14.414	14	190.894	1.82	16	236.435	1.50	5	109.228
240×224	28	224	193.990	238.4	222.4	238.54	223.86	+3.6	16.723	14	210.960	1.71	16	255.938	1.47	6	133.738
250×234	30	240	207.846	248.4	232.4	248.54	233.86	+0.6	13.259	14	220.788	1.86	16	266.768	1.55	6	131.483
260×244	31	248	214.774	258.4	242.4	258.54	243.86	+1.6	14.414	14	230.592	1.80	16	276.231	1.53	6	132.855
280×264	34	272	235.559	278.4	262.4	278.54	263.86	-0.4	12.104	14	250.651	1.90	16	297.014	1.59	6	131.973
300×284	36	288	249.415	298.4	282.4	298.54	283.86	+1.6	14.414	14	270.915	1.79	16	316.665	1.55	7	156.483
320×304	38	304	263.272	318.4	302.4	318.54	303.86	+3.6	16.723	14	290.961	1.72	16	336.253	1.52	7	159.228
340×324	41	328	284.056	338.4	322.4	338.54	323.86	+1.6	14.414	14	310.684	1.78	16	356.494	1.57	7	158.345
360×344	44	352	304.841	358.4	342.4	358.54	343.86	-0.4	12.104	14	330.731	1.85	16	377.099	1.62	8	179.228
380×364	46	368	318.697	378.4	362.4	378.54	363.86	+1.6	14.414	14	350.972	1.78	16	396.809	1.58	8	181.973
400×384	48	384	332.554	398.4	382.4	398.54	383.86	+3.6	16.723	14	370.963	1.72	16	416.458	1.55	9	206.483
420×404	51	408	353.338	418.4	402.4	418.56	403.84	+1.6	14.414	14	390.739	1.77	16	436.662	1.59	9	205.600
440×424	54	432	374.123	438.4	422.4	438.56	423.84	-0.4	12.104	14	410.779	1.83	16	437.155	1.63	9	204.717
450×434	55	440	381.051	448.4	432.4	448.56	433.84	+0.6	13.259	14	420.697	1.80	16	466.855	1.62	10	227.855
460×444	56	448	387.979	458.4	442.4	458.56	443.84	+1.6	14.414	14	430.934	1.77	16	476.907	1.60	10	229.228
480×464	58	464	401.836	478.4	462.4	478.56	463.84	+3.6	16.723	14	450.963	1.72	16	496.602	1.58	11	253.738
500×484	61	488	422.620	438.4	482.4	498.56	483.84	+1.6	14.414	14	470.776	1.77	16	516.779	1.61	11	252.855

**Table 11 Dimensions for Involute Splines of Module 10**  
(Clauses 6.2 to 6.10)



All dimensions in millimetres.																	
NOMINAL SIZE										INTERNAL SPLINE			EXTERNAL SPLINE				
										Pin Dia	Measurement Between pine	Deviation Factor	Pin Dia	Measurement Over Pins	Deviation Factor	Tooth Thickness Over z' Teeth	
																	Tooth thickness deviation factor 0.866
$d_1 \times d_2$	Z	$d_0$	D	$d_3$	D	d Min	d Max	xm	$l_a = s_a$	d	M	f	d	$M_a$	$f_a$	Z'	
80×60	6	60	51.962	78	58	78.11	59.89	+4.5	20.904	18	42.206	1.71	35	130.845	1.03	2	48.104
85×65	7	70	60.622	83	63	83.11	64.89	+2.0	18.017	18	44.776	2.50	25	113.476	1.13	2	46.069
90×70	7	70	60.622	88	68	88.11	69.89	+4.5	20.904	18	50.446	1.67	30	127.942	1.06	2	48.569
95×75	8	80	69.282	93	73	93.11	74.89	+2.0	18.071	18	56.557	2.34	25	126.117	1.19	2	46.535
100×80	8	80	69.282	98	78	93.11	79.89	+4.5	20.904	18	62.206	1.72	28	136.452	1.13	2	49.035
105×85	9	90	77.942	103	83	103.11	84.89	+2.0	18.017	18	65.378	2.18	25	134.743	1.19	2	47.000
110×90	9	90	77.942	108	88	108.11	89.89	+4.5	20.904	18	70.836	1.69	28	145.104	1.13	2	49.500
120×100	10	100	86.603	118	98	118.11	99.89	+4.5	20.904	18	82.207	1.72	25	150.226	1.20	3	77.173
130×110	12	120	103.923	128	108	128.12	109.88	-0.5	15.131	16	97.638	2.14	20	150.592	1.43	2	45.897
140×120	12	120	103.923	138	118	138.12	119.88	+4.5	20.904	18	102.207	1.72	25	170.806	1.23	3	78.104
150×130	14	140	121.244	148	128	148.12	129.88	-0.5	15.131	18	110.471	2.62	20	170.719	1.46	3	74.035
160×140	14	140	121.244	158	138	158.12	139.88	+4.5	20.904	18	122.207	1.72	25	191.284	1.27	3	79.035
170×150	16	160	138.564	168	148	168.12	149.88	-0.5	15.131	18	130.832	2.37	20	190.821	1.48	3	74.966
180×160	16	160	138.564	178	158	178.12	159.88	+4.5	20.904	18	142.207	1.73	22	204.139	1.33	4	107.173
190×170	18	180	155.885	188	168	188.12	169.88	-0.5	15.313	18	151.063	2.24	20	210.906	1.50	3	75.897
200×180	18	180	155.885	198	178	198.12	179.88	+4.5	20.904	18	162.207	1.73	22	224.401	1.36	4	108.104
210×190	20	200	173.205	208	188	208.12	189.88	-0.5	15.131	18	171.225	2.15	20	230.976	1.52	4	104.035
220×230	20	200	173.205	218	198	218.12	199.88	+4.5	20.904	18	182.207	1.73	22	244.627	1.38	4	109.035
260×240	22	220	190.526	238	218	238.14	219.89	+4.5	20.904	18	202.207	1.73	22	264.823	1.40	5	137.173
280×260	24	240	207.846	248	228	248.14	229.86	-0.5	15.131	18	211.440	2.04	20	271.088	1.54	4	105.897
260×240	24	240	207.846	258	238	258.14	239.86	+4.5	20.904	18	222.207	1.73	20	279.696	1.44	5	138.104
280×260	26	260	225.167	278	258	278.14	259.86	+4.5	20.904	18	242.207	1.73	20	299.816	1.46	5	139.035
300×280	28	280	242.487	298	278	298.14	279.86	+4.5	20.904	18	262.207	1.73	20	319.922	1.47	6	167.173
320×300	30	300	259.808	318	298	318.14	299.86	+4.5	20.904	18	282.207	1.73	20	340.017	1.48	6	168.104
340×320	32	320	277.128	338	318	338.14	319.86	+4.5	20.904	18	302.207	1.73	20	360.103	1.49	6	169.035
360×340	34	340	294.449	358	338	358.14	339.86	+4.5	20.904	18	322.207	1.73	20	380.181	1.50	7	197.173
380×360	36	360	311.769	378	358	378.14	356.86	+4.5	20.904	18	342.207	1.73	20	400.252	1.51	7	198.104
400×380	38	380	329.090	398	378	398.14	379.86	+4.5	20.904	18	362.207	1.73	20	420.317	1.52	7	199.035
420×400	40	400	346.410	418	398	418.14	399.86	+4.5	20.904	18	382.207	1.73	20	440.376	1.53	8	227.173
440×420	42	420	363.731	438	418	438.14	419.84	+4.5	20.904	18	402.207	1.73	20	460.431	1.54	8	228.104
450×430	44	440	381.051	448	428	448.16	429.84	-0.5	15.131	18	411.838	1.87	20	417.374	1.62	8	224.035
460×440	44	440	381.051	458	438	458.16	439.84	+4.5	20.904	18	422.207	1.73	20	480.482	1.54	8	229.035
480×460	46	460	398.372	478	458	478.16	459.84	+4.5	20.904	18	442.207	1.73	20	500.529	1.55	9	257.173
500×480	48	480	415.692	498	478	498.16	479.84	+4.5	20.904	18	462.207	1.73	20	520.572	1.55	9	258.104



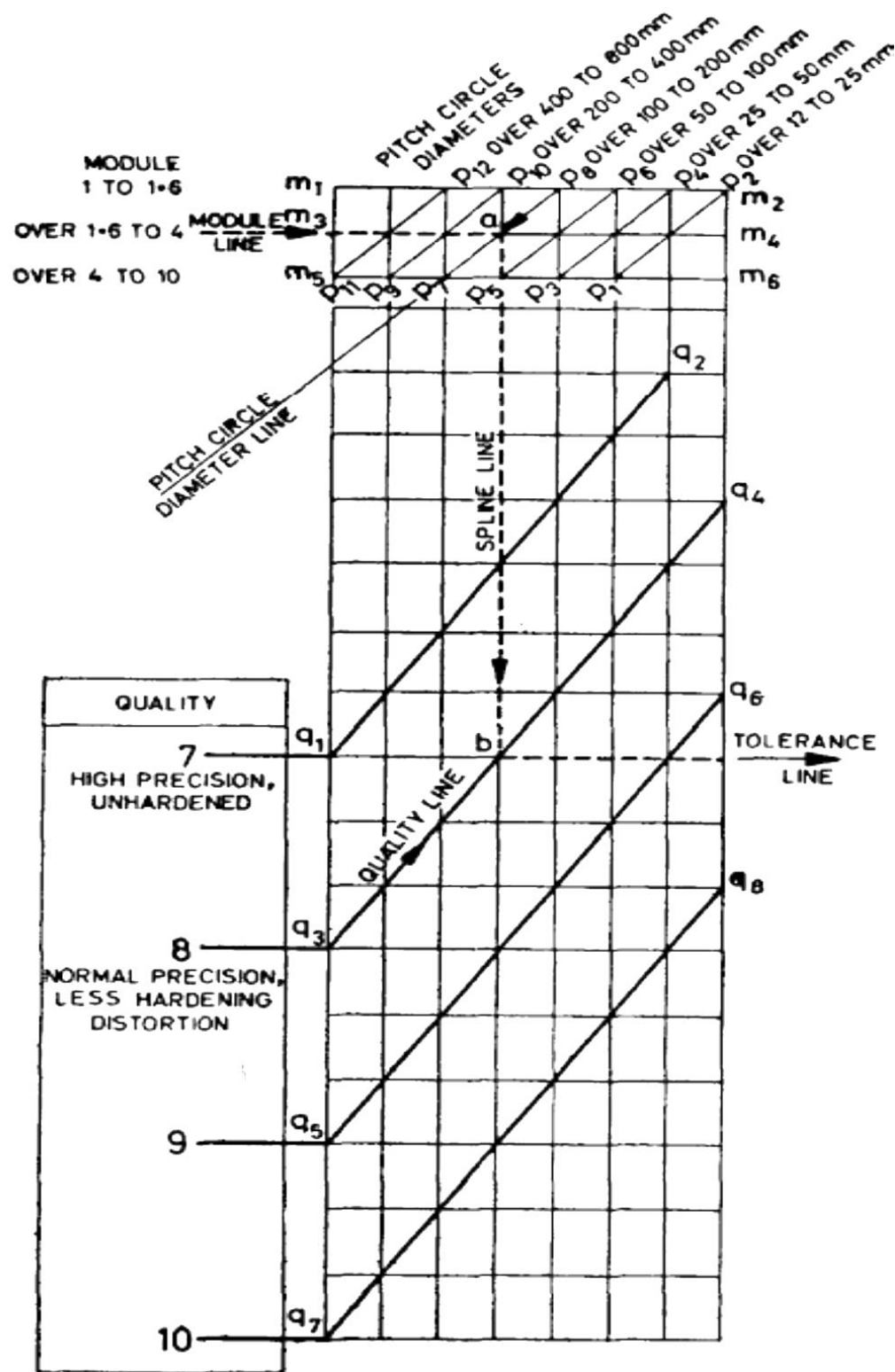

Table 12 Tolerance for Spline Tooth Thickness and Space Width  
(Clauses 0.6 and 6.11.3)

VALUES IN MICROMETRES														
INTERNAL SPLINE Deviations of Space Width Upper ES Lower EI					EXTERNAL SPLINE Deviation of Tooth Thickness Upper ES Lower EI									
E	F	G	H	m	k	j	h	g	f	e	d	c	b	A
+45	+36	+27	+18	+27	+18	+9	0	-9	-18	-27	-36	-45	-54	-63
+27	+18	+9	0	+9	0	-9	-18	-27	-36	-45	-54	-63	-72	-81
+50	+40	+30	+20	+30	+20	+10	0	-10	-20	-30	-40	-50	-60	-70
+30	+40	+10	0	+10	0	-10	-20	-30	-40	-50	-60	-70	-80	-90
+55	+44	+33	+22	+33	+22	+11	0	-11	-22	-33	-44	-55	-66	-77
+33	+22	+11	0	+11	0	-11	-22	-33	-44	-55	-66	-77	-88	-99
+62	+50	+37	+25	+37	+25	+12	0	-12	-25	-37	-50	-62	-75	-87
+37	+25	+12	0	+12	0	-13	-25	-37	-50	-62	-75	-87	-100	-112
+70	+56	+42	+28	+42	+28	+14	0	-14	-28	-42	-56	-70	-84	-98
+42	+28	+14	0	+14	0	-14	-28	-42	-56	-70	-84	-98	-112	-126
+80	+64	+48	+32	+48	+32	+16	0	-16	-32	-48	-64	-80	-96	-112
+48	+32	+16	0	+16	0	-16	-32	-48	-64	-80	-96	-112	-128	-144
+90	+72	+54	+36	+54	+36	+18	0	-18	-36	-54	-72	-90	-108	-126

+54	+36	+18	0	+18	0	-18	-36	-54	-72	-90	-108	-126	-144	-162
+100	+80	+60	+40	+60	+40	+20	0	-20	-40	-60	-80	-100	-120	-140
+60	+40	+20	0	+20	0	-20	-40	-60	-80	-100	-120	-140	-160	-180
+112	+90	+67	+45	+67	+45	+22	0	-22	-45	-67	-90	-112	-135	-157
+67	+45	+22	0	+22	0	-23	-45	-67	-90	-112	-135	-157	-180	-202
+125	+100	+75	+50	+75	+50	+25	0	-25	-50	-75	-100	-125	-150	-175
+75	+50	+25	0	+25	0	-25	-50	-75	-100	-125	-150	-175	-200	-225
+140	+112	+84	+56	+84	+56	+28	0	-28	-56	-84	-112	-140	-168	-196
+84	+56	+28	0	+28	0	-28	-56	-84	-112	-140	-168	-196	-224	-252
+158	+126	+95	+63	+95	+63	+32	0	-32	-63	-95	-126	-158	-189	-221
+95	+63	+32	0	+32	0	-31	-63	-95	-126	-158	-189	-221	-252	-284
+178	+142	+07	+71	+107	+71	+36	0	-36	-71	-107	-142	-178	-213	-249
+107	+71	+36	0	-36	0	-35	-71	-107	-142	-178	-213	-249	-284	-320
+200	+160	+20	+80	+120	+80	+40	0	-40	-80	-120	-160	-200	-240	-280
+120	+80	+40	0	+40	0	-40	-80	-120	-160	-200	-240	-280	-320	-360
+225	+180	+35	+90	+135	+90	+45	0	-45	-90	-135	-180	-225	-270	-315
+135	+90	+45	0	+45	0	-45	-90	-135	-180	-225	-270	-315	-360	-405
+250	+200	+50	+100	+150	+100	+50	0	-50	-100	-150	-200	-250	-300	-350
+150	+100	+50	0	+50	0	-50	-100	-150	-200	-250	-300	-350	-400	-450
+275	+200	+65	+110	+165	+110	+55	0	-55	-110	-165	-220	-275	-330	-385
+165	+110	+55	0	+55	0	-55	-110	-165	-220	-275	-330	-385	-440	-495

**Table 13 Example of Effective and Actual Dimensions, Tolerances for Different Fits**

(Clause 6.11.4)

SPLINE TYPE	TOLERANCES ZONE		FIT
	Effective	Actual	
Internal Spline	H	E	Press fits
	m	h	
	k	g	
External Spline	j	f	Locating fit
	h	e	
	g	d	
	f	c	Sliding fits
	e	b	

**ANNEX A**  
*(Foreword)*  
**INSTRUCTIONS FOR USING TABLE 12**

**A-1 GENERAL**

**A-1.1** This appendix covers the method for reading the tolerance values on space width and tooth thickness of four qualities of involute splines, represented by the quality lines  $q_1, q_2, q_3, q_4$ , etc. The modules up to

10 have been divided into three ranges, represented by module lines  $m_1m_2, m_3m_4$  and  $m_5m_6$ . The pitch circle diameters up to 800 mm have been divided into 6 ranges, represented by the lines  $p_1, p_2, p_3, p_4$ , etc.

**A-2 PROCEDURE FOR USING THE TABLE**

**A-2.1** The procedure has been explained with a particular example of external spline of module 2, pitch circle diameter 120 mm, quality 8 and tolerance m.

**A-2.2** The module line for the spline of module 2 is  $m_3m_4$ . The pitch circle diameter line for 120 mm is  $p_7p_8$ . The pitch the module line  $m_3m_4$  and pitch circle diameter line  $p_7p_8$  meet at a point 'a', and from the point 'a', a spline line leads down to the quality line  $q_3q_4$ , corresponding to quality 8, meeting at point 'b'. The tolerance value is read under the tolerance symbol m against the point 'b'. The tolerance value for the tooth thickness of the spline is + 60 and + 20 micrometres.