

भारतीय मानक मसौदा

हिमपात प्रमापी — विशिष्टि
(IS 6806 का पहला पुनरीक्षण)

Draft Indian Standard

Snow Gauge — Specification
(*First Revision of IS 6806*)

ICS 07:060

Not to be reproduced without permission of BIS or use as Standard	Last date for receipt of comment is XXXX
--	---

Meteorological Instruments Sectional Committee, PGD 21

FOREWORD

(Formal clauses will be added later)

A snow gauge is a type of instrument used by meteorologists and hydrologists to gather and measure the amount of solid precipitation over a set period of time.

Accuracy in the measurement of snowfall is of great importance in irrigation, flood control, power generation, and in conservation of water resources.

In addition to this standard, the following Indian Standards covers specification of various types of precipitation gauges in use at meteorological and other observatories in the country:

- a) IS 4849 : 1992 Meteorology — Rain measures — Specification (*first revision*)
- b) IS 5225 : 1992 Meteorology — Raingauge, non-recording — Specification (*first revision*)
- c) IS 5235 : 1992 Meteorology — Raingauges recording — Specification (*first revision*)

This standard was first published in 1973. The first revision has been taken up to include the latest developments based on the usage in the field. In this revision, the following changes have been made:

- a) UDC number has been replaced by ICS number;
- b) The references have been updated;
- c) The designation of aluminium alloy for the rim of the collector has been updated in accordance with the latest edition of IS 617; and
- d) In **4.1(b)**, word ‘animal’ has been deleted.

For the purpose of deciding whether a particular requirement of this standard is complied with, the final value, observed or calculated expressing the result of a test or analysis, shall be rounded off in accordance with IS 2 : 2022 ‘Rules for rounding off numerical values’. The number of significant places retained in the rounded off value should be the same as that of the specified value in this standard.

Indian Standard
SNOW GAUGE — SPECIFICATION

1 SCOPE

This standard specifies the requirements for 500 cm² snow gauge with windshield, and the measure glasses to be used with it.

2 REFERENCES

The following standards contain provisions which through reference in this text, constitute provisions of this standard. At the time of publication, the editions indicated were valid. All standards are subject to revision and parties to agreements based on this standard are encouraged to investigate the possibility of applying the most recent editions of the standards indicated below:

<i>IS No.</i>	<i>Title</i>
IS 617 : 1994	Cast aluminium and its alloys — Ingots and castings for general engineering purposes — Specification (<i>third revision</i>)
IS 1382: 1981	Glossary of terms relating to glass and glassware (<i>first revision</i>)
IS 4426 : 1992	Methods of sampling laboratory glassware (<i>first revision</i>)
IS 4849 : 1992	Meteorology — Rain measures — Specification (<i>first revision</i>)

3 DESCRIPTION

The snow gauge consists of a 60 cm deep collector having an area of 500 cm² mounted inside an alter pattern windshield one metre in diameter. The gauge with its shield is installed on stand pipe support so that the orifice of the collector is at a height of 1.5 m above the ground when installed on a concrete platform rising 10 cm from ground level. Solid precipitation collected in the gauge is melted and the precipitation in millimetres is measured using the measure glasses conforming to the requirements given in Annex A.

4 MATERIAL

4.1 The collector shall be made of a suitable material having the following properties:

- a) Rigidity and strength with no distortion or other deterioration when exposed to widely varying climatic conditions in the open air, while at the same time being light in weight;
- b) Freedom from attack by insect or fungoid life;
- c) Smooth and permanent surface finish so as to facilitate free flow of precipitation; and
- d) Low thermal conductivity so as to minimize evaporation losses or condensation gains.

4.1.1 While any material satisfying the above requirements may be used fibre glass reinforced polyester is considered as a suitable material. The material selected for the fabrication of the collector shall be such that it is capable of withstanding the weathering effects of exposure in the open for a period of not less than 15 years.

4.1.2 The material for the rim of the collector shall be gun metal or aluminium alloy conforming to Grade 4635 of IS 617.

4.1.3 The ring for the wind shield and the connector for the ring shall be of non-magnetic and non-rusting stainless steel.

4.1.4 The supporting columns shall be cast from anodized aluminium.

4.1.5 All other components shall be of anodized aluminium or similar material fully protected against the effects of exposure in the open for prolonged periods extending for a number of years.

4.1.6 The nuts, bolts and washers shall be of galvanized iron fully protected against rusting and corrosion.

5 DIMENSIONS

5.1 The dimensions for the snow gauge and shield shall be as given in Fig. 1.

5.2 The inside diameter of the collector rim shall be correct within ± 0.5 mm of the specified value of 252.2 mm when measured in any four directions and the mean of the four values shall be within ± 0.2 mm of the specified value.

6 GENERAL REQUIREMENTS

6.1 Collector

The collector shall be a cylindrical canister with a rim cemented firmly at the top. The rim, having a knife edge, shall be truly circular. The inner surface of the rim and the inside vertical wall of the canister shall be in one plane. The entire inner and outer surfaces of the collector shall have a smooth and permanent finish. Seams, if any, shall be of adequate strength and be water-tight. The bottom of the collector, if made of metal, shall be folded, brazed and sealed water-tight.

The collector, if made of metal, shall be highly polished and lacquered; if made from glass fibre reinforced polyester, shall have a glossy finish, coloured light green or cream and have a nominal thickness of at least 2.5 mm.

6.2 Supporting Columns and Wind Shield

6.2.1 The collector shall rest over two cylindrical supporting columns provided with flanges. The two supporting columns shall be fitted to each other with bolts, nuts and washers.

6.2.2 The top and bottom surfaces of the flanges of the columns shall be at right angles to the longitudinal axis. The mounting of the columns shall be such that the rim of the collector when mounted is truly horizontal.

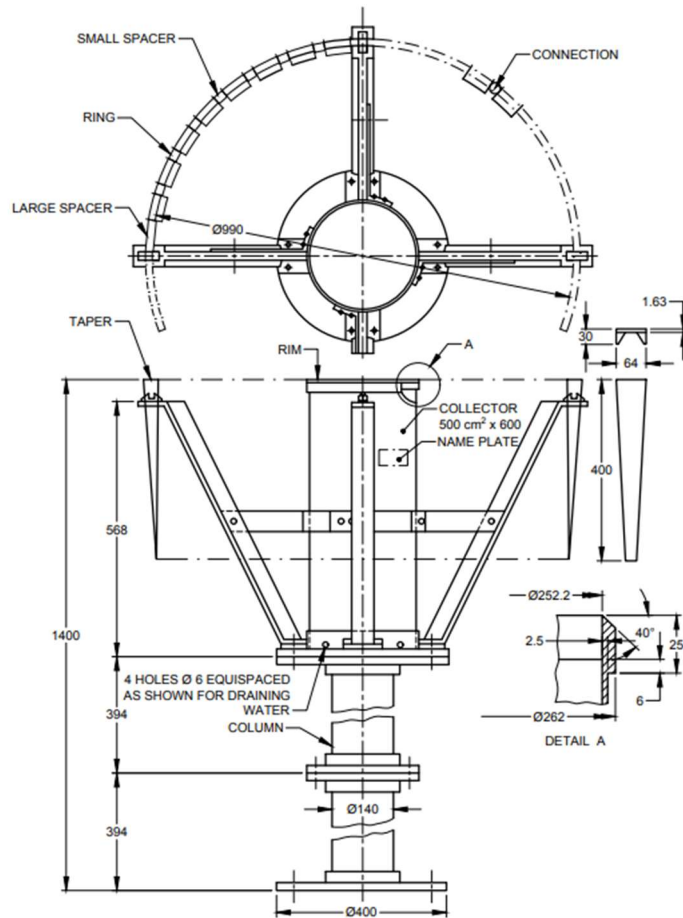

All dimensions are in millimetres.

FIG. 1 DIMENSIONS FOR SNOW GAUGE, 500 cm²

6.2.3 The flanged socket shall be capable of receiving the collector easily such that when assembled the rim of the collector is truly horizontal.

6.2.4 The support frame of the wind shield shall be made of four aluminium T pieces of 40 × 40 × 6 section fitted over the flanged socket at right angles to one another. It shall be fitted to the socket by nuts and bolts, such that it may be easily dismantled for packing.

6.2.5 When completely assembled, the orifice of the collector shall be 1.4 m from the bottom of the lower column and in the same plane as the top of the aluminium tapers.

6.2.6 The ring of the shield shall be of stainless steel and shall have a diameter of approximately 1 m. The two ends of the ring shall be joined by means of a stainless steel connector.

6.2.7 The tapers of the shield shall be made of aluminium and they shall be 32 in number. They shall hang freely and be capable of swinging in gentle breeze, when assembled on the stainless steel supporting ring. The individual tapers shall be spaced evenly over the ring by means of 28 long and 8 short aluminium spacers.

7 DESIGNATION

For the purposes of inquiry or order, the snow gauge shall be designated by the nominal area of the collector.

Example:

A complete snow gauge with windshield conforming to this standard shall be designated as "Snow Gauge 500 cm² IS 6806".

8 MARKING

8.1 Each snow gauge shall bear the following inscription engraved legibly and neatly on a brass name plate which shall be cemented firmly on the collector:

- a) The inscription 'SNOW GAUGE, 500 cm²';
- b) Manufacturer's name or recognized trade-mark; and
- c) Serial number and year of manufacture, for example, No. 123/20232.

8.2 BIS Certification Marking

The product(s) conforming to the requirements of this standard may be certified as per the conformity assessment schemes under the provisions of the *Bureau of Indian Standards Act, 2016* and the Rules and Regulations framed thereunder, and the products may be marked with the Standard Mark.

9 PACKING

The collector shall be wrapped in tissue paper and packed carefully in a strong cardboard carton. All other parts shall be dismantled, and wrapped in corrugated packing paper and packed in a wooden box along with the carton containing the collector. The packing shall be such that the collector and the other parts shall safely withstand normal transit risks. Alternatively, the instrument shall be packed as agreed to between the supplier and the purchaser.

10 TESTING AND INSPECTION

All the snow gauges shall be tested individually for conformity to all the requirements of this specification.

ANNEX A
(Clause 3)

REQUIREMENTS OF MEASURE GLASSES FOR SNOW GAUGE, 500 cm²

A-1 TERMINOLOGY

For the purpose of this annex, the definitions given in IS 1382 shall apply.

A-2 TYPES

The measure glasses shall be of the following two types suitable for use with a collector of 500 cm²:

- a) 10 mm capacity (Fig. 2), and
- b) 20 mm capacity (Fig. 3).

A-3 DESIGNATION

For the purposes of inquiry or order, the measure glasses shall be designated by their maximum capacities.

Example:

‘Measure Glass for Snow Gauge, 500 cm², 10 mm Capacity, IS 6806’.

A-4 REQUIREMENTS

The measure glasses shall meet the requirements given in IS 4849 for the material, limit of alkalinity, general construction and finish.

A-5 DIMENSIONS

The dimensions of the measure glasses shall be as given in Fig. 2 and 3.

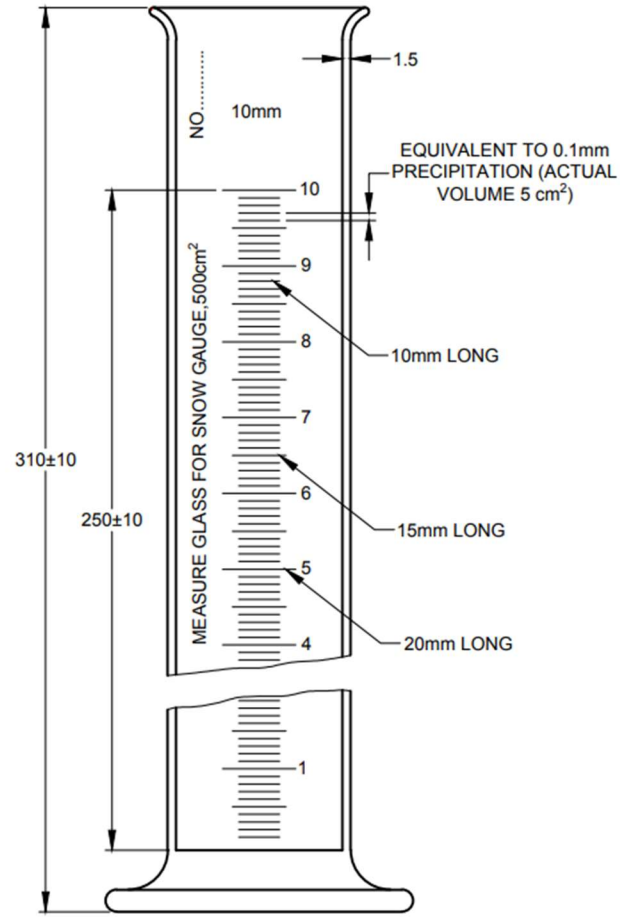

All dimensions are in millimetres.

FIG. 2 MEASURE GLASS FOR SNOW GAUGE 500 cm², 10 mm CAPACITY

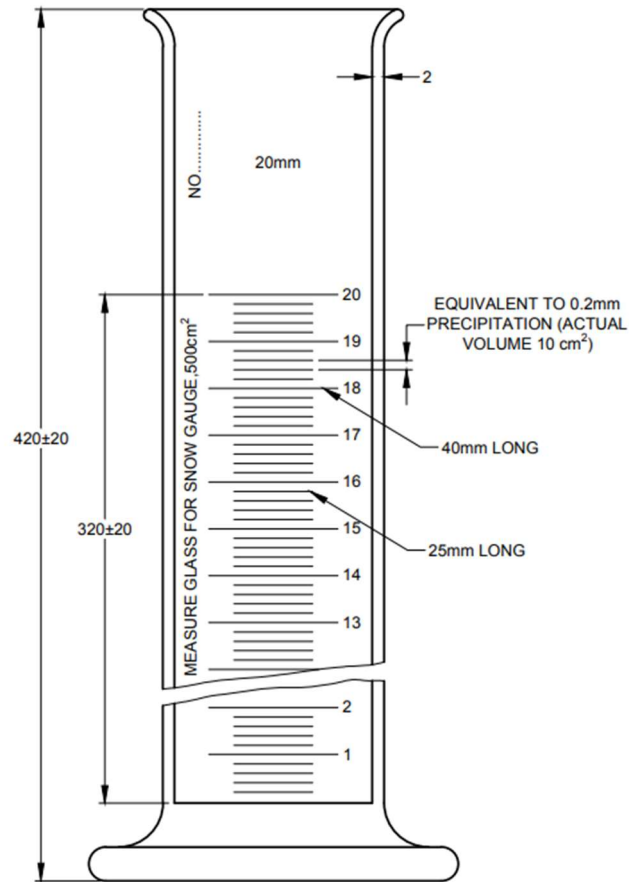

All dimensions are in millimetres.

FIG. 3 MEASURE GLASS FOR SNOW GAUGE, 500 cm², 20 mm CAPACITY

A-6 GRADUATION AND FIGURING

The measure glasses shall meet the requirements laid down in IS 4849 for graduation and figuring except for the following deviations.

A-6.1 Graduations shall be engraved for every 0.1 mm as shown in Fig. 2 for the measure glass having capacity of 10 mm and for every 0.2 mm as shown in Fig. 3 for that having capacity of 20 mm.

A-6.2 Every full mm graduation line shall be plainly figured by numbers not less than 5 mm high immediately opposite the end of the graduation line as shown in Fig. 2 and 3. Alternatively, the figures shall be placed immediately above the extended line to which they refer.

A-7 BASIS OF CALIBRATION

The measure glass of 10 mm capacity shall contain 500 cm³ or 498.03 g of distilled water corresponding to 10 mm of rainfall when filled to its highest graduation mark, at a temperature of 27 °C, 65 percent relative humidity and a pressure of 760 mm Hg. The lower edge of the water meniscus shall be in the horizontal plane containing the graduation marks. Similarly, the measure glass of 20 mm capacity shall contain 1 000 cm³ or 996.06 g of distilled water when filled to the highest graduation mark under the same conditions.

A-8 TOLERANCES

The maximum permissible error at any point as also the maximum permissible difference between errors at any two points not less than 10 subdivisions removed from one another shall be ± 0.05 mm of snowfall in the measure glass having capacity of 10 mm while it shall be ± 0.1 mm for the measure glass having capacity of 20 mm. For testing and when using the measure glass the scale reading shall correspond to the position of then lower edge of the water meniscus.

A-9 MARKING

The measure glasses shall bear the following inscriptions engraved legibly:

- a) The mark '10 mm' or '20 mm' as the case may be, above the scale between the highest graduation mark and the top of the measure glass;
- b) The inscription 'Measure glass for snow gauge 500 cm²' engraved to the left of the scale;
- c) The manufacturer's name or his recognized trade-mark; and
- d) Serial number and year of manufacture, for example, 'No. 123/2023.

A-10 PACKING

Each measure glass shall be packed in a cardboard carton suitably cushioned as agreed to between the purchaser and the supplier.

A-11 SAMPLING AND INSPECTION

Representative samples shall be drawn and adjudged for conformity to this standard as prescribed in IS 4426.