

BUREAU OF INDIAN STANDARDS
DRAFT FOR COMMENTS ONLY
Not to be reproduced without permission of BIS or used as Standard

Doc.: PGD 21 (25029)WC
IS 5900 : 2024

भारतीय मानक मसौदा

केश आर्द्रतालेख — विशिष्टि
(IS 5900 का पहला पुनरीक्षण)

Draft Indian Standard

Hair Hygrograph — Specification
(First Revision of IS 5900)

ICS 07.060

Meteorological Instruments Committee, PGD 21	Sectional	Last date for receipt of comment is 10 July 2024
---	-----------	--

FOREWORD

(Formal clause will be added later on)

The most common method of measuring atmospheric humidity is by means of psychrometers, either of the stationary screen type or the portable ventilated type. However, permanent records of the atmospheric humidity at meteorological and other observing stations are obtained with hygrographs in which the changes in length with a relative humidity of a humidity sensitive element, usually human hair, are recorded on a paper chart wound on a revolving drum.

Any absorbing material tends to equilibrium with its environment in terms of both temperature and humidity. The water-vapour pressure at the surface of the material is determined by the temperature and the amount of water bound by the material. Any difference between this pressure and the water-vapour pressure of the surrounding air will be equalized by the exchange of water molecules.

This standard was first published in 1970. The first revision has been taken up to include the latest developments based on the usage in the field. In this revision, following changes have been made:

- a) In **4.1(b)**, the word ‘animal’ has been deleted; and,
- b) Calibration and maintenance requirements have been added.

For the purpose of deciding whether a particular requirement of this standard is complied with, the final value, observed or calculated, expressing the result of a test or analysis, shall be rounded off in accordance with IS 2: 2022 ‘Rules for rounding off numerical values (*second revision*)’. The number of significant places retained in the rounded off value should be the same as that of the specified value in this standard.

Indian Standard
HAIR HYGROGRAPH — SPECIFICATION
(First Revision)

1 SCOPE

This standard specifies the requirements for hair hygrograph. The scale value of the instrument is such that atmospheric relative humidity correct up to one percent may be read on a suitable chart.

2 REFERENCES

The standards listed below contain provisions which, through reference in this text, constitute provisions of this standard. At the time of publication, the editions indicated were valid. All standards are subject to revision, and parties to agreements based on this standard are encouraged to investigate the possibility of applying the most recent editions of the standards listed below.

<i>IS No</i>	<i>Title</i>
5924 : 1988	Specification for clock mechanisms and drums for meteorological instruments.
5947 : 1970	Specification for charts for recording meteorological instruments.

3 DESCRIPTION

The humidity sensor consists of a bundle of human hair held between two adjustable jaws, the whole assembly being mounted on a hair movement plate. The variations with length of the hair strands due to changes in the relative humidity are measured by the displacement of the centre of the hair strands transmitted by a lever and a pair of cams to the pen arm so that the movement of the pen is a linear function of the relative humidity. A means of fine adjustment is provided by a setting screw which alters the distance between the jaws. The design also incorporates an arrangement for altering the scale value by adjusting the position of the hook on the lever. The complete recording mechanism, with the clock drum, is mounted on the base of the instrument. The hinged cover has a wide viewing window. The hair element is protected by a suitable guard. The hair hygrograph or hygrometer is considered to be a satisfactory instrument for use in situations or during periods where extreme and very low humidities are seldom or never found. The mechanism of the instrument should be as simple as possible, even if this makes it necessary to have a non-linear scale. This is especially important in industrial regions, since air pollutants may act on the surface of the moving parts of the mechanism and increase friction between them.

4 MATERIAL

4.1 The material used for the fabrication of the base and cover shall be either a light and durable metal like aluminium alloy or any other material having the following properties:

- a) Rigidity and strength with no distortion or other deterioration when exposed to widely varying climatic conditions, while at the same time being light in weight;
- b) Freedom from attack by insect and fungoid life;
- c) Smooth and permanent surface finish; and

- d) Low coefficient of thermal expansion so as to minimize alterations of the frame due to temperature changes.

4.2 While any material satisfying the requirements as given in 4.1 may be used, aluminium alloy and glass reinforced polyester are considered as suitable materials for moulding the base and cover.

4.3 The material used for the remaining components of the instrument shall be non-magnetic, non-corrosive and non-rusting material like stainless steel, brass or similar material with suitable anticorrosive paint. The material used shall be such that it is capable of being finished to the specified dimensions and is not affected by exposure to widely varying climatic conditions both at inland and coastal stations.

5 DIMENSIONS

5.1 The general arrangement and dimensions of the hair hygrograph shall be as indicated in Fig. 1.

5.1.1 While slight modifications in the details of the instrument are permissible, the general arrangement shall be as shown in Fig. 1.

5.1.2 The means for zero adjustment and scale value alteration are left to the manufacturer who may also alter the system of linkages to suit his design provided the final product satisfies all the other requirements of this specification.

6 GENERAL REQUIREMENTS

6.1 Hair Assembly

6.1.1 The hair strands usually consisting of 20 to 25 hairs shall have an effective length of 190 mm \pm 10 mm excluding the portions held in the adjustable jaws. The complete hair assembly shall be mounted on a hair movement plate fixed to the base of the instrument. The hair element shall be mounted outside the cover as shown in Fig.1 and shall be suitably protected by a perforated guard so as to leave the hairs freely exposed to the atmosphere. The guard shall have 6 perforations per square centimetre, the diameter being 3.2 mm.

6.1.2 The hair strands shall be suitably treated to be free from all traces of oil and grease.

6.1.3 The various spindles shall be made of stainless steel or similar non-rusting material and shall be perfectly straight and well-polished. They shall be held in suitable bearings so that they rotate smoothly and freely with minimum friction and withstand normal wear and tear.

6.1.4 A setting key shall be provided to enable the zero position of the pen to be adjusted with a precision of one percent on the chart by smooth adjustment of the distance apart of the jaws. When not in actual use, the key shall be fixed to the base.

6.1.5 An arrangement for adjusting the position of the hair hook on the lever shall be provided for adjusting the magnification of the instrument whenever necessary.

6.1.6 The hair movement cam and the pen arm cam shall be made and assembled in such a manner that the pen arm is rotated relative to the pen arm cam and the pen arm is horizontal when the cams are in their mean position.

6.1.7 The contacting surface of the two cams shall be smooth, well-polished and free from lacquer, to keep frictional errors to the minimum and the two cams shall be held in contact at all times by means of a small light spring.

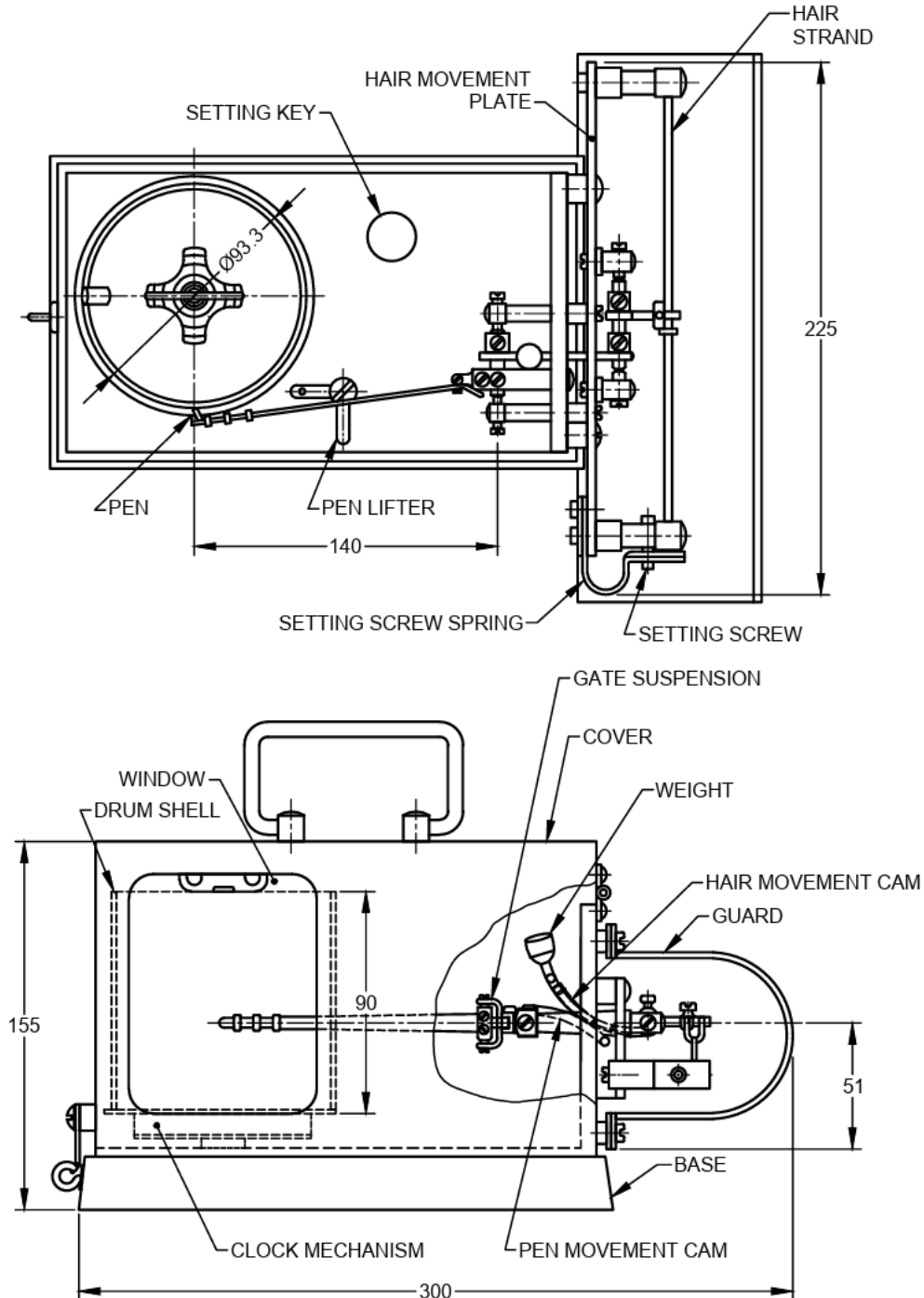

All dimensions are in millimetres.

FIG.1 GENERAL ARRANGEMENT AND DIMENSIONS OF HAIR HYGROGRAPH

6.1.8 The counter weight placed at the upper end of the hair movement cam shall be such that the force applied by the hook on the hairs when the cams are in their mean position equals 16 g (approx. 0.16 N).

6.2 Pen Arm Assembly

6.2.1 The pen arm shall be made of hard-drawn German silver sheet or similar material. The arm may be ribbed in the centre for rigidity and strength, if necessary.

6.2.2 The length of the pen arm with the pen shall be exactly 140 mm so that the pen shall follow exactly the time grid arcs on the chart.

6.2.3 The pen arm shall be mounted in such a way that there is no play of the arm in the suspension and the angle of contact of the pen on the chart, as well as the pressure of the pen on the chart may be adjusted.

6.3 Cover and Base

6.3.1 The cover shall be provided with a cut-away window to enable the record on the chart to be seen without opening the cover. The window shall be covered with a transparent sheet of glass or acrylic plastic which may be slid in grooves framing the window and fixed in position. Alternatively, the cover shall be such as to provide a panoramic view of the inside. In either case the cover shall be attached to the base with a strong rustproof hinge.

6.3.2 A suitable rustproof locking device shall be provided to enable the cover to be locked to the base.

6.3.3 A suitable handle shall be fixed securely on the top of the cover.

6.4 Recording Mechanism

6.4.1 The recording mechanism shall be such that the movement of the pen on the chart is linear through the entire range of the instrument from 0 to 100 percent and the pen travels a vertical distance of 81 mm for a change in relative humidity from 0 to 100 percent.

6.4.2 The recording mechanism shall be free enough to denote clearly on the chart a change in relative humidity of the order of ± 1 percent.

6.4.3 The friction in the instrument shall be kept to the minimum so that the record obtained on the chart is continuous without steps, that is, when there is a gradual change in humidity, the record does not show abrupt changes of relative humidity with traces showing periods of constant humidity interposed in between.

6.4.4 The recording pen shall have the dimensions as given in Fig. 2 and shall yield a clear trace on the chart at all times. Suitable fibre tipped disposable pen can also be used.

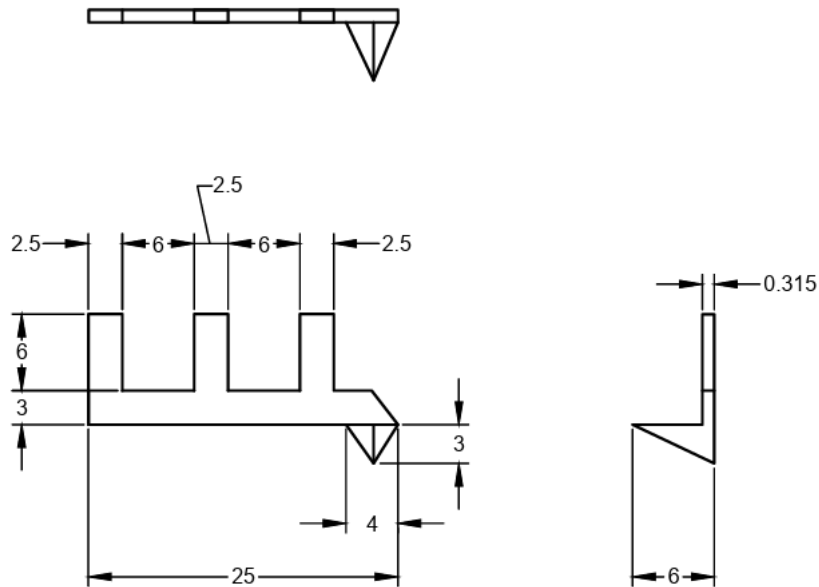

All dimensions are in millimetres.

FIG .2 DIMENSIONS FOR RECORDING PEN

6.4.5 The instrument shall be provided with a clock mechanism and drum conforming to IS 5924.

6.4.6 The chart (*see* IS 5947) shall be daily or weekly depending upon the clock mechanism and drum.

7 WORKMANSHIP AND FINISH

7.1 The external surfaces of the hygrograph shall have a smooth and permanent finish.

7.2 The instrument shall be painted in any light colour, but light blue is preferred.

7.3 All metal parts shall be suitably treated so as to protect them from rusting or other deterioration, particularly at coastal stations.

7.4 When finally assembled, the movement of the pen arm on the chart shall have minimum friction so that the pen returns to its original position when gently moved down manually through a distance equal to one small division on the chart. The instrument shall meet this requirement positions of the pen on the chart.

7.5 During the up & down movement of the pen, the chart shall be parallel to the time grid marked on it.

8 TESTS, CALIBRATION AND MAINTANANCE

8.1 The hygrograph, when tested in a properly designed and operated humidity cabinet, giving enough time for the instrument to reach equilibrium, shall not have errors exceeding ± 5 percent at any point above 20 percent on the scale.

8.2 The hygrograph shall have a sensitivity of about ± 2 percent in steady conditions of relative humidity.

8.3 After the instrument has been checked against a psychrometer and adjusted to read the ambient relative humidity, it shall indicate a relative humidity of 95 percent after attaining equilibrium when the hair is wetted with distilled water.

8.4 When the hourly readings of the hygrograph are plotted against the corresponding relative humidity values from the readings of the psychrometer, the mean line passing through the scattered points shall be a straight line of slope 45° passing through the origin.

8.5 Calibration

8.5.1 The readings of a hygrograph should be checked as frequently as is practical. In the case where wet- and dry-bulb thermometers are housed in the same thermometer screen, these may be used to provide a comparison whenever suitable steady conditions prevail, but otherwise field comparisons have limited value due to the difference in response rate of the instruments.

8.5.2 Accurate calibration can only be obtained through the use of an environmental chamber and by comparison with reference instruments.

8.5.3 The 100 percent humidity point may be checked, preferably indoors with a steady air temperature, by surrounding the instrument with a saturated cloth (though the correct reading will not be obtained if a significant mass of liquid water droplets forms on the hairs).

8.5.4 The ambient indoor humidity may provide a low relative humidity checkpoint for comparison against a reference aspirated psychrometer. A series of readings should be obtained.

8.5.5 Long-term stability and bias may be appraised by presenting comparisons with a reference aspirated psychrometer in terms of a correlation function.

8.6 Maintenance

8.6.1 Observers should be encouraged to keep the hygrometer clean.

8.6.2 The hair should be washed at frequent intervals using distilled water on a soft brush to remove accumulated dust or soluble contaminants. At no time should the hair be touched by fingers. The bearings of the mechanism should be kept clean and a small amount of clock oil should be applied occasionally. The bearing surfaces of any linearizing mechanism will contribute largely to the total friction in the linkage, which may be minimized by polishing the surfaces with graphite. This procedure may be carried out by using a piece of blotting paper rubbed with a lead pencil.

8.6.3 With proper care, the hairs may last for several years in a temperate climate and when not subject to severe atmospheric pollution. Recalibration and adjustment will be required when hairs are replaced.

9 MARKING

9.1 Each hygrograph shall have the following information engraved legibly and neatly on a name plate which shall be cemented firmly on the base of the instrument:

- a) Name of the instrument — 'Hair Hygrograph';
- b) Word 'Daily' or 'Weekly' corresponding to the clock mechanism;
- c) Designation of the chart to be used with the instrument;
- d) Manufacturer's name or recognized trade-mark; and
- e) Serial number and year of manufacture, for example, No. 123/2024.

9.2 BIS Certification Marking

The product(s) conforming to the requirements of this standard may be certified as per the conformity assessment schemes under the provisions of the *Bureau of Indian Standards Act, 2016* and the Rules and Regulations framed thereunder, and the products may be marked with the standard mark.

10 PACKING

Each hygrograph without the clock mechanism and drum, shall be wrapped in dust-proof paper taking care not to damage the hair element, after lightly tying the pen arm to the pen lifter to prevent excessive oscillations of the pen arm during transit. It shall then be placed in a corrugated cardboard carton with suitable cushioning. The clock mechanism and drum shall be carefully packed separately in another cardboard carton to avoid any risk of damage or deformation during transit. Both the cartons shall then be packed in a strong wooden box using suitable packing material. Alternatively, the instrument shall be packed as agreed to between the supplier and the purchaser.

11 TESTING AND INSPECTION

Each hygrograph shall be tested individually for conformity to all the requirements of this specification.