

BUREAU OF INDIAN STANDARDS

DRAFT FOR COMMENTS ONLY

Not to be reproduced without permission of BIS or used as Standard.

Doc: PGD 14(20543) WC

August 2024

भारतीय मानक मसौदा

संश्लिष्ट (प्लास्टिक) सरकवां फास्टनर्स (विशेष प्रयोजन)

भाग 2 परीक्षण एवं परिमाण विधियाँ

[IS 14181(Part 2) का पहला पुनरीक्षण]

Draft Indian Standard

Synthetic (Plastic) Slide Fasteners (Special Purpose)

Part 2 Test and Measurement Methods

[First Revision of IS 14181(Part 2)]

ICS 61.040; 83.140.01

Consumer Products and Allied Equipment's
Sectional Committee, PGD 14

Last date for receipt of comment is:
6 September 2024

FOREWORD

(Formal clauses will be added later)

This standard describes the method of tests and measurements for various dimensions, physical properties, performance requirements, colour fastness, etc, of synthetic slide fasteners and is mandatory to be read in conjunction with Part 1 of this standard. This standard is published in three parts. The other parts in this series are:

- IS 14181 (Part 1) Specification, selection and ordering guideline of the product
(*second revision*)
- IS 14181 (Part 3) Test report formats

This standard was first published in 2002. This first revision has been brought out to include the latest developments based on the usage in the field. In this revision, references have been updated and editorial corrections have been made.

While preparing this standard assistance has been derived from the following:

- a) Schedule No. CQA, T & C/TC-15/7 for plastic slide fasteners issued by Controller at Quality Assurance (Textile and Clothing), Government of India (DGQA, Ministry of Defence)

b) Schedule No. DMSRDE/TEX-2/89/1 for plastic slide fasteners issued by Defence Materials and Stores Research and Development Establishment, Kanpur (DRDO, Ministry of Defence)

c) IS 3148 : 2024 ‘Slide fasteners (general purpose) — Specification (*fourth revision*)’ was also referred.

For the purpose of deciding whether a particular requirement of this standard is complied with, the final value, observed or calculated, expressing the result of a test or analysis shall be rounded off in accordance with IS 2 : 2022 ‘Rules for rounding off numerical values (*second revision*).’ The number of significant places retained in the rounded off value should be the same as that of the specified value in this standard.

Draft Indian Standard

**SYNTHETIC (PLASTIC) SLIDE FASTENERS (SPECIAL PURPOSE)
PART 2 TEST AND MEASUREMENT METHODS**

[*First Revision of IS 14181(Part 2)*]

1 SCOPE

This standard (Part 2) specifies methods for tests and measurements, for determination of various dimensions, physical properties, security and performance requirements and colour fastness, of the synthetic (plastic) slide fasteners as specified in IS 14181 (Part 1).

2 REFERENCES

The following standards contain provisions which through reference in this text, constitute provision of this standard. At the time of publication, the editions indicated were valid. All standards are subject to revision, and parties to agreements based on this standard are encouraged to investigate the possibility of applying the most recent editions of the standards indicated below:

<i>IS No.</i>	<i>Title</i>
IS/ISO 105-B02 : 2014	Textiles — Tests for colour fastness: Part B02 Colour fastness to artificial light: Xenon arc fading lamp test
IS/ISO 105-C10 : 2006	Textiles — Tests for colour fastness: Part C10 Colour fastness to washing with soap or soap and soda
IS/ISO 105-E02 : 2013	Textile — Tests for colour fastness: Part E02 Colour fastness to sea water (<i>first revision</i>)
IS/ISO 105-E04 : 2013	Textiles — Tests for Colour Fastness: Part E04 Colour fastness to perspiration
IS/ISO 105-X05 : 1994	Textiles — Tests for colour fastness: Part X05 Colour fastness to organic solvents
IS 196 : 2024	Atmospheric conditions for testing (<i>second revision</i>)
IS 715 : 2002	Coated abrasives — Specification (<i>fourth revision</i>)
IS 14181 (Part 1) : 2024	Synthetic (plastic) slide fasteners (Special purpose): Part 1 Specification, selection and ordering guideline of the product (<i>second revision</i>)

3 APPARATUS

Test apparatus required have been shown in the text for measurements/tests (*see 7*).

4 TEST PIECES

Preparation of test pieces has been shown in the test for measurements/tests (*see 7*).

5 CONDITIONING

The samples shall be conditioned under standard atmospheric condition, in accordance with IS 196.

6 MEASUREMENTS

6.1 Textile chain width, textile chain thickness, lace width, tape width, exposed tape width, tape extension, puller length, diameter of monofilament and length of fasteners, required as per **8.1** of IS 14181 (Part 1), shall be measured/checked as per methods given in Annex A.

7 TESTS

7.1 Security Tests

7.1.1 The methods of test for various security requirements, required as per **10.2** of IS 14181 (Part 1) are given in Table 1.

Table 1 Security Tests

(Clause 7.1.1)

Sl No.	Test	Method of Test, Ref to
(1)	(2)	(3)
i)	Security of interlocking of textile chain to Lateral load or cross-wise strength of textile chain with 25 mm length in grip	Annex B
ii)	Fold over security of textile chain (for obverse and reverse fold)	Annex C
iii)	Security of attachment of top stop (All types)	Annex D
iv)	Security of attachment of bottom stop	Annex E
v)	Security of attachment of retainer to longitudinal load (open-end fasteners)	Annex F
vi)	Security of attachment of retainer to lateral load (open end fasteners)	Annex G
vii)	Security of attachment of puller to slider	Annex H
viii)	Security of slider lock holding	Annex J

7.2 Performance Tests

The method of test for various performance requirements, required as per **10.3** of IS 14181 (Part 1), and are given in Table 2.

Table 2 Performance Tests
(Clause 7.2)

SI No.	Test	Method of test, Ref to IS
(1)	(2)	(3)
i)	Reciprocating movement of slider under load	Annex K
ii)	Resistance to abrasion under load (Cycles)	Annex L
iii)	Resistance to heat under load	Annex M
iv)	Remeshability of fastener	Annex N

7.3 Colour Fastness Requirements

The method of test for various colour requirements, required as per **10.4** of IS 14181 (Part 1), are given in Table 3.

Table 3 Colour Fastness Requirements
(Clause 7.3)

SI No.	Test	Method of test, Ref to IS
(1)	(2)	(3)
i)	Colour fastness to light	IS/ISO 105-B02
ii)	Colour fastness to perspiration	IS/ISO 105-E04
iii)	Colour fastness to sea water	IS/ISO 105-E02
iv)	Colour fastness to washing	IS/ISO 105-C10
v)	Colour fastness to organic solvents	IS/ISO 105-X05

ANNEX A

(Clause 6.1)

METHODS OF MEASUREMENT

A-1 The method of measurement for various parts of the slide fastener shall be as given in Table 4.

Table 4 Methods of Measurement

(Clause A-1)

Sl No.	Description	Method of Measurement
(1)	(2)	(3)
i)	Puller Length	For measuring the puller length, the puller shall be placed in the downward position such that it lies over the closed chain. The length shall then be measured, parallel to the chain, to the nearest millimetre.
ii)	Length of Fasteners	The slide fastener is kept with its slider(s) in extreme top end/end positions and the puller facing downwards (towards mouth of slider). The fastener length shall be the overall measurement from the bottom of the bottom stop or retainer to the top of the top stop or top of the slider(s), whichever is extreme (<i>see</i> Fig. 1). The first 200 mm length or part thereof of the fastener shall be subjected to tolerance of up to -5 mm or + 8 mm for light special and up to -7 mm or +10 mm for all other designations. Further tolerance of +1 percent shall be allowed for the subsequent length of the fastener.
iii)	Tape Width	Keep the fastener flat on the surface. Measure the width of the tape at the ends of Tape Extension as shown in Fig. 1 with a scale having graduations in mm nearest to 1 mm. The average of 5 readings can be taken as the width of the tape.
iv)	Exposed Tape Width	Exposed tape width is the width between the outer tape edge and inner shoulder line of formed coil of the textile stringer (left or right) of a slide fastener (<i>see</i> Fig. 1). It is measured by means of a scale nearest to 1 mm keeping the fastener flat on the surface.
v)	Tape Extensions	It is the extent of tape measured beyond the stoppers/slide fastener length at both ends (<i>see</i> Fig. 1). It is measured by means of a scale nearest to 1 mm keeping the fastener flat

			on the surface. Tape extensions are necessary for proper/secure attachment of slide fastener to its end product. The tape extension shall be pinked at the end (s).
vi)	Textile Width	Chain	<p>The slider is removed from the fasteners and broken into two halves at its neck. Slider mouth width as shown in Fig. 2 which corresponds</p> <p>to the chain width of the fastener is measured as the minimum distance between inside of the parallel flanges of the slider. (<i>see</i> Fig. 2) section ,4A and measure by calliper to the nearest 0.05 mm.</p>
vii)	Textile Thickness	Chain	<p>The slider is removed from the fastener, height of slider mouth opening (near the mouth) as shown in Fig. 2 which corresponds to the chain thickness of the fastener is measured. (<i>see</i> Fig. 2) section BB and measure by calliper to the nearest 0.05 mm.</p>
viii)	Lace Width		<p>A micro measure eye glass No. 7 with torch shall be used. By keeping one end of the lace parallel to the O-axis in the eye glass, the point where the other end of the lace coincides is the width of the lace. The least count of the micro measure eyeglass should be 0.1 mm. Average of 5 readings in one sample shall be taken as the lace width (<i>see</i> Fig. 3).</p>
ix)	Diameter of Monofilament	of	<p>To measure the diameter of mono-filament of a zipper/chain, the following procedure shall be followed:</p> <ul style="list-style-type: none">a) Open the zip by bringing the slider downwards.b) Remove the top stop from the right-hand side stringer of obverse face.c) Cut the complete scoop from the upper end and remove the stitching thread from looper face by holding the cut end of stitching thread and pulling the same. Remove the stitches on the covering tape for about 8 cm length and pull off the covering tape so that the coil loses the grip with the tape (as shown in Fig. 4).d) Cut a portion of the coil (say 2.5 cm). Using a Vernier, measure the diameter of the monofilament of the coil at the shaded portion\ “A” as shown in Fig. 4 without pulling/elongating the interlocking elements of the coil.

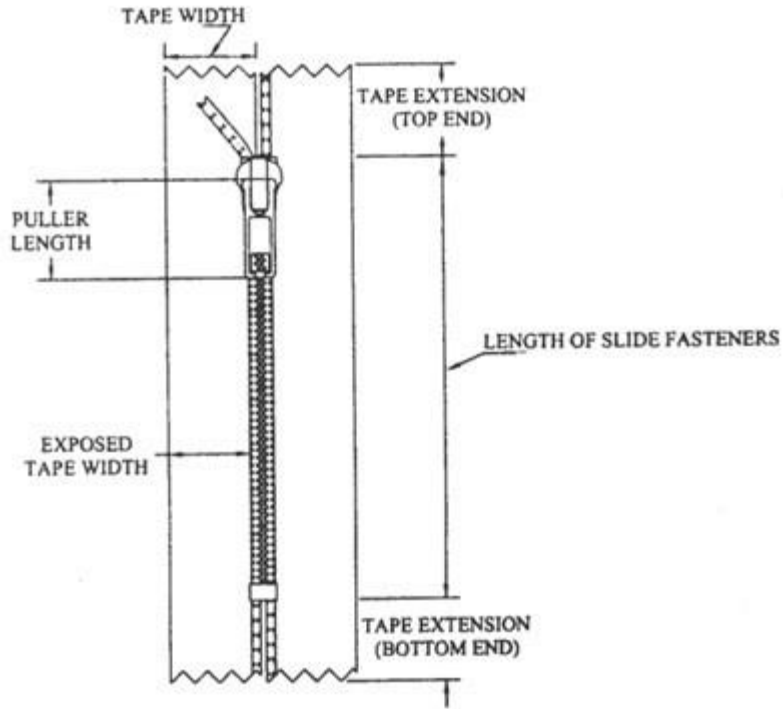
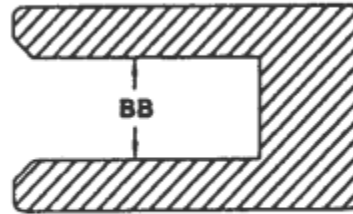
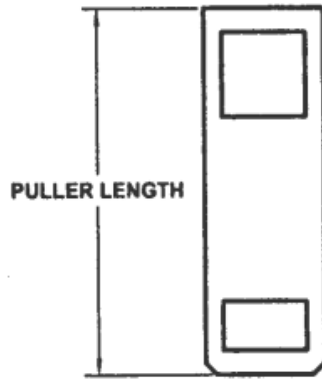

FIG. 1 DIMENSIONS



AA-MOUTH WIDTH

BB-MOUTH OPEN

FIG. 2 DIMENSIONS (SLIDER)

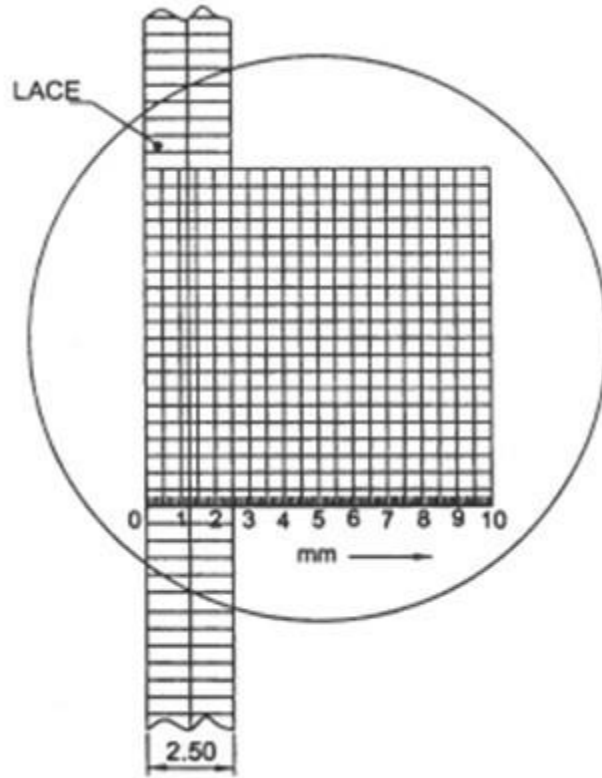

FIG. 3 MEASUREMENT OF LACE WIDTH (PICK GLASS)

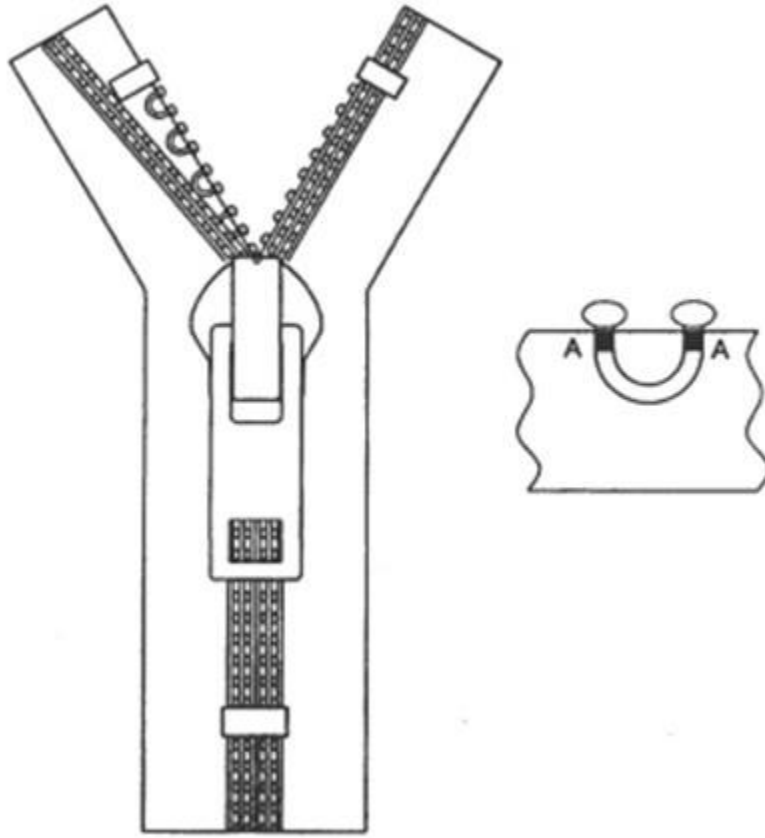

FIG. 4 MEASURING THE DIAMETER OF MONOFILAMENT

ANNEX B
[Table 1, Sl No.(i)]

METHOD OF TESTING FOR SECURITY OF INTERLOCKING OF TEXTILE CHAIN TO LATERAL LOAD OR CROSSWISE STRENGTH OF TEXTILE CHAIN

B-1 OUTLINE

The test specimen is subjected to lateral load under controlled conditions while the slide fastener is in the closed position.

B-2 APPARATUS

The testing machine is of the constant-rate-of-traverse type and the speed of the opening of the jaws is (100 ± 15) mm/min. The load range is such that the breaking load of the test specimen falls between 15 and 85 percent of the maximum load on the scale.

The gripping jaws or other securing devices have a gripping surface 25 mm wide. The jaws shall be so constructed and finished as not to damage the tape and not to allow the specimen under test to slip (*see Fig. 5*).

B-3 PROCEDURE

The test specimen is secured in place with the gripping jaws/devices so arranged that at least half the width of each tape is gripped and there is at least 50 mm of chain on either side of the jaw. The machine is then set in operation until the specified loading is reached, unless the specimen fails earlier.

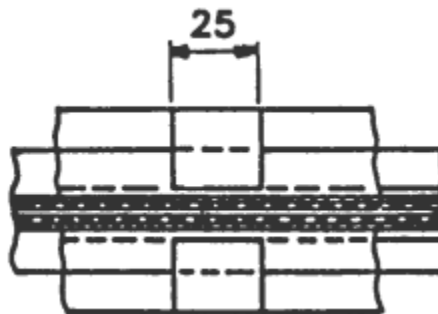

All dimensions are in millimetres.

FIG. 5 FASTENERS, CROSSWISE STRENGTH OF TEXTILE CHAIN

NOTE — It is recommended that the load scale be calibrated at least once every 12 months, using dead weight added successively.

ANNEX C
[Table 1, Sl No. (ii)]

METHOD OF TESTING FOR FOLDOVER SECURITY OF TEXTILE CHAIN (FOR BOTH OBVERSE AND REVERSE)

C-1 OUTLINE

The test specimen is subjected to lateral load in folded condition under controlled conditions while the slide fastener is in closed position.

C-2 APPARATUS

The testing machine is of the constant rate of traverse type and the speed of the opening of the Jaws is 100 ± 15 mm/min. The load range is such that the breaking load of the test specimen falls between 15 and 85 percent of the maximum load on the scale.

The gripping jaws or other securing devices have a gripping surface of 12.5 mm wide. The jaws shall be so constructed and finished as not to damage the tape and not to allow the specimen under test to slip.

C-3 PROCEDURE

C-3.1 The test specimen is secured in place with the gripping jaws minimum 3 mm to 5 mm gap from the zipper chain (*see* Fig. 6).

C-3.2 Both the sides of the tape should be clamped (Zipper in folded condition) with uniform gap between the jaw and zipper chain to have uniform load in the interlocking stringers.

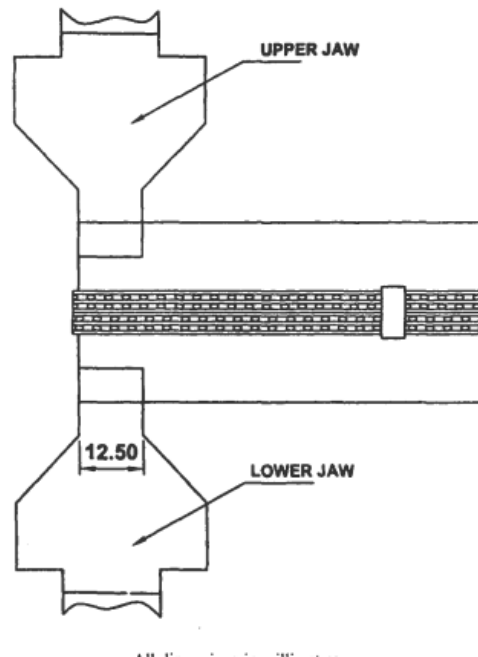

All dimensions are in millimetres

FIG. 6 FOLDOVER STRENGTH

C-3.3 Test specimen length can be of minimum 13 cm to facilitate testing operation.

C-3.4 Folded chain can be fixed with a pin or stapler pin to facilitate fixing the specimen in folded condition in the gripping jaws.

C-3.5 The folded test specimen should not exceed the right ends of the jaws. That is the folded specimen and the gripping jaws should be in straight line with each other in the right end of the jaws in order to effect load only in 12.5 mm width from the folded edge of the chain.

C-3.6 The machine is then set in operation until the specified load is reached, unless the specimen fails earlier. (Further load is applied till the interlocking stringers disengages from each other.) The load applied for disengaging the interlocking stringers can be noted as the fold over strength of the test specimen. The same procedure shall be applied for testing both obverse and reverse fold over strength of the zipper chain. The specimen shall not be tested in a same spot for obverse and reverse fold over strength.

C-3.7 The specimen shall be removed from the jaws after testing. Neither the tape nor the formed coil shall get damaged while testing.

ANNEX D

[Table 1, Sl No. (iii)]

METHOD OF TESTING OF SECURITY OF ATTACHMENT OF TOP STOP (ALL TYPES)**D-1 OUTLINE**

Each stop is subjected to tension while the fastener is secured in position, load being applied by pulling the slider body in such a way so as to bring the stoppers under pressure.

D-2 APPARATUS

The testing machine as described in Annex B shall be used as far as possible. Schematic arrangement is shown in Fig. 7.

D-3 PROCEDURE

The test specimen is in the closed position with the slider body adjacent to the top-stop. At one end of the test specimen, a fixture is made to rest below the slider body as shown in Fig. 7 and the other end of the test specimen is fixed on the moving jaw. The machine is then set in operation until the specified loading is reached, unless the test specimen fails earlier.

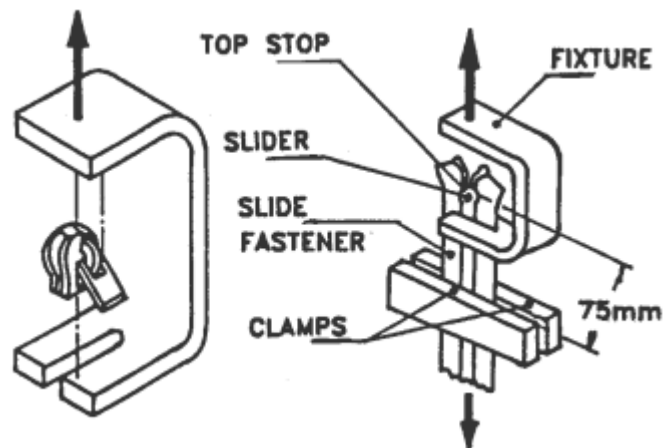

ANNEX E
[Table 1, S1No. (iv)]

METHOD OF TESTING OF SECURITY OF ATTACHMENT OF BOTTOM STOP

E-1 OUTLINE

Each stop is subjected to tension while the fastener is secured in position, load being applied by pulling the slider body in such a way so as to bring the stoppers under pressure.

E-2 APPARATUS

The testing machine as described in Annex B shall be used as far as possible. Schematic arrangement is shown in Fig. 8.

E-3 PROCEDURE

The test specimen is in the open position, the slider body being adjacent to the bottom stop. The angle between the textile stringers is the normal angle of opening, which is usually between 40° and 60° (*see* Fig. 8). The rest of the procedure is as described in **D-3**.

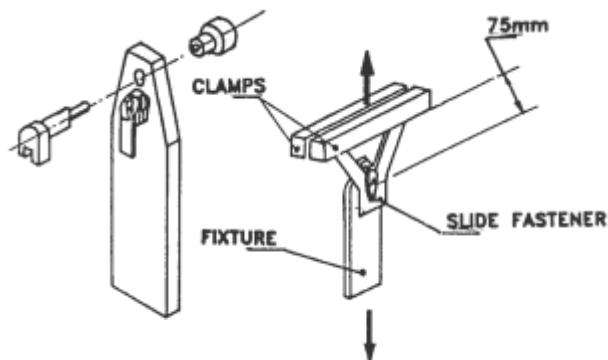

FIG. 8 SECURITY OF ATTACHMENT TEST FOR BOTTOM STOPS

ANNEX F
[Table 1, SI No. (v)]

**METHOD OF TESTING OF SECURITY OF ATTACHMENT OF RETAINER FOR
LONGITUDINAL LOAD (OPEN END FASTENER)**

F-1 OUTLINE

The retainer is subjected to longitudinal load while the slide fastener is in the closed position.

F-2 APPARATUS

A testing machine as described in Annex B shall be used as far as possible. The schematic arrangement is shown in Fig. 9.

F-3 PROCEDURE

With the test specimen in the closed position, the chain is clamped into one jaw of the testing machine, steps being taken to avoid damaging the chain. A slotted plate, shaped to clear the tape, chain and pin and to bear against the whole of the top edges of the retainer is clamped into the other jaw. The machine is set in operation until the specified loading is reached unless the specimen fails earlier.

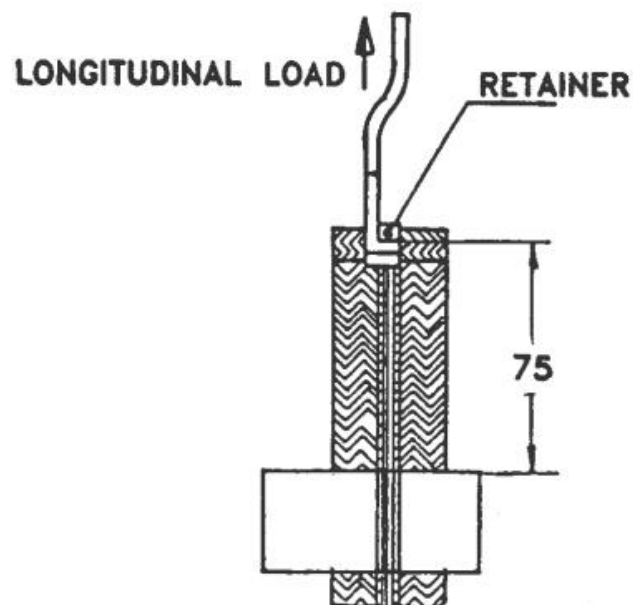

All dimensions are in millimetres

FIG. 9 SECURITY OF ATTACHMENT OF RETAINER FOR LONGITUDINAL LOAD TEST

ANNEX G

[Table 1, SI No. (vi)]

**METHOD OF TESTING OF SECURITY OF ATTACHMENT OF
RETAINER TO LATERAL LOAD (OPEN END FASTENER)**

G-1 OUTLINE

The test specimen is subjected to lateral load under controlled conditions while the slide fastener is in the closed position.

G-2 APPARATUS

A testing machine as described in Annex B shall be used as far as possible. The gripping jaws shall be 25 mm wide and would be so constructed and finished as not to damage the tape while tightening and not to allow the test specimen under test to slip (*see* Fig. 10).

G-3 PROCEDURE

The test specimen shall be secured in the gripping jaws of the testing machine with the edges of the jaw parallel to and 3 mm from the sides of the retainer. The jaws will be arranged so that the separating pin aligns with the edges of the jaws. The machine is set in operation until the specified loading is reached, unless the test specimen fails earlier.

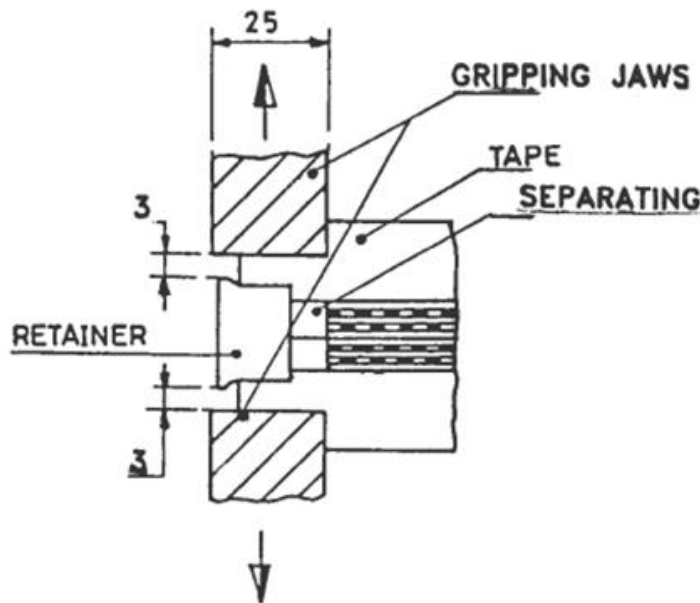

All dimensions are in millimetres

FIG. 10 SECURITY OF ATTACHMENT OF RETAINER TO LATERAL LOAD TEST

ANNEX H
[Table 1, SI No. (vii)]

METHOD OF TESTING OF SECURITY OF ATTACHMENT OF PULLER TO SLIDER

H-1 OUTLINE

The puller is subjected to tension while the slider is rigidly supported.

H-2 APPARATUS

A testing machine as described in Annex B shall be used as far as possible. A masking device for the slider, such as a face-plate or blanking off plate, is required so that tension is confined to the puller and its attachment to the slider (*see* Fig. 11).

H-3 PROCEDURE

The slider is placed on the blanking off plate, the puller passing through the hole in the plate as shown in Fig. 11. The blanking off plate is secured to one of the jaws of the testing machine and the puller is then secured to the other jaw of the testing machine, so that tension is applied at 90° to the puller attachment.

The testing machine is set in operation until specified load is reached, unless the specimen fails earlier.

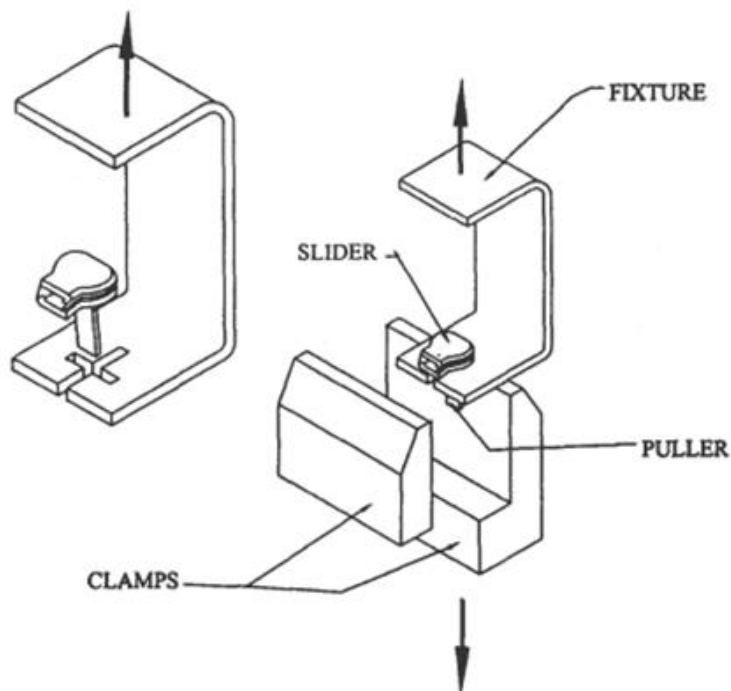

FIG. 11 SECURITY OF ATTACHMENT TEST FOR PULLER

ANNEX J

[Table 1, Sl No. (viii)]

METHOD OF TESTING SECURITY OF SLIDER LOCK HOLDING

J-1 OUTLINE

The slider is locked on the chain and the locking device subjected to tension, load being applied at 180° to the device via the chain stringers in such a way as to bring the locking device under pressure from the chain.

J-2 APPARATUS

A testing machine as described in Annex B shall be used as far as possible. Figure 12 gives a diagrammatic sketch of the arrangement.

J-3 PROCEDURE

The test specimen is in the open position with the locking device locked into the chain 25 mm from the top stops. Set the jaws 50 mm apart and secure the top of the stringer into the jaws adjacent to the top stop so that the top of the slider is 25 mm from the edge of each jaw. Set the machine in motion and increase the load until the locking mechanism slips or the specimen fails.

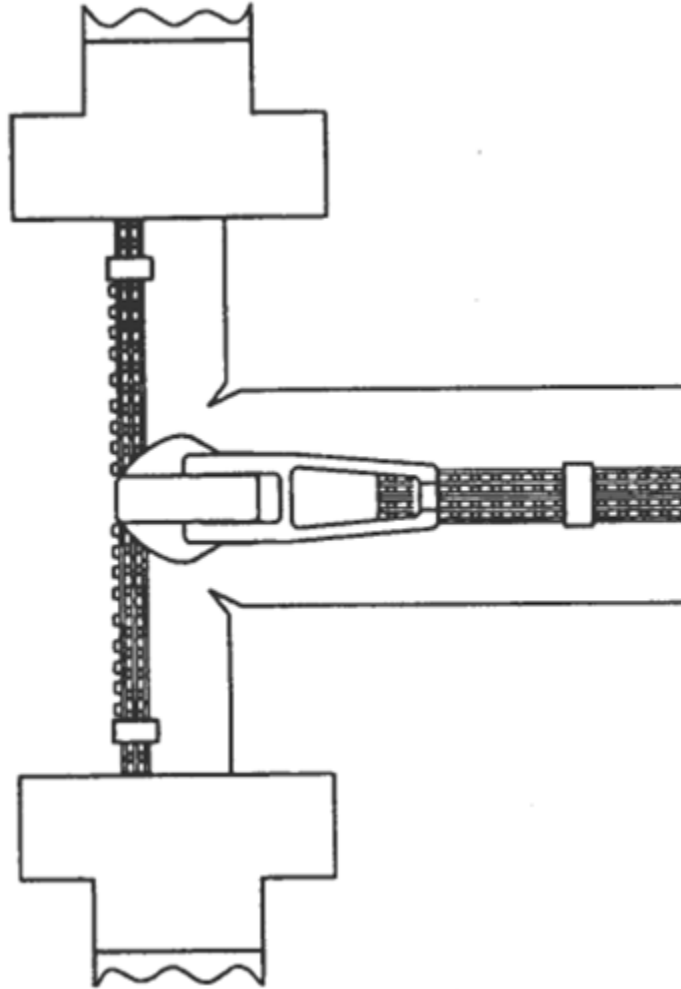

FIG. 11 LOCK HOLDING TEST

ANNEX K
[Table 2, SI No. (i)]

METHOD OF TESTING THE RECIPROCATING MOVEMENT OF SLIDER UNDER LOAD

K-1 OUTLINE

The test specimen is subjected to a specified number of cyclic operations while under lateral and longitudinal tensions.

K-2 APPARATUS

The testing machine, which operates in the vertical plane, is constructed on the lines as shown in Fig. 13 so as to provide the following facilities:

a) Means of holding the specimen firmly at the bottom end with the fastener in the closed position, steps being taken to avoid damaging the fastener.

b) Means of separately gripping the two stringers at the other end so that the fastener beyond the slider is open. These gripping devices form the means of applying longitudinal spring balance loads to the fasteners and thus required connecting together by swivel-plate or other similar device, so that the fastener may be centralized when the loads are applied. It is also necessary for their gripping devices to swivel at the points on connection to the swivel plate to facilitate the operation of the slider on the test specimen. The distance between the gripping devices is such that, when the slider is at the lowest point in the cycle, the two ends of the fasteners subtend an angle of approximately 60° .

c) Means of gripping the tapes securely midway along the traversed length at opposite points of the testing zone so that the clamps maybe subjected to load by means of spring balances. The clamps are so mounted that they are 'floating', that is, free to follow the natural direction of the opening of the fasteners under test.

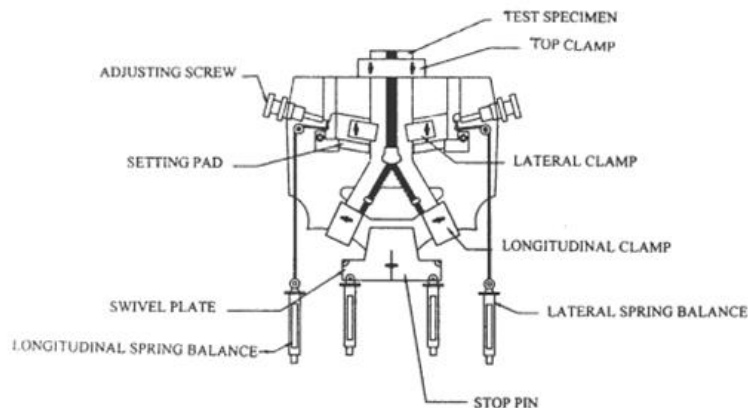

FIG. 13 RECIPROCATING MOVEMENT TEST FOR SLIDER

The clamps shall be capable of moving 5 mm in the direction of the pulleys, and setting pads are provided to hold the clamps in position until they are secured to the tapes. The spring balances are of the tubular type and are of 9 kg capacity for the lateral tension and of 4.5 kg capacity for the longitudinal load. In each case, a scale of 35 mm represents a 4.5 kg range.

The overall length of the balance, when closed at zero reading, shall not exceed 165 mm, excluding the holding ring and the hook. The extended length shall not exceed 229 mm at full load extension, excluding the holding ring and the hook. The weight corresponding to the interval between consecutive graduations shall not exceed 0.1 kg. These graduations which are permanent and legible, are not less than 0.8 mm apart. The error permitted on verification shall not exceed the weight corresponding to half the interval between consecutive graduations, that is, not more than 0.06 kg.

d) Means of applying regular harmonic reciprocating action through the medium of the puller, to the slider on the test specimen. The clamp or other gripping device is made in two parts fitting together by such means as V-grooves and springs. One part of the clamp is attached to the puller and the other to the reciprocating device, so as to facilitate indirect form of connection.

K-3 PROCEDURE

The test specimen is mounted in the vertical plane so that the bottom stop is upwards. The stringers are left separate at the other end so that they may be individually mounted in the machine. The lateral and longitudinal loadings are as given in Table 4.

Table 5 Lateral and Longitudinal Loads
(Clause K-3)

SI No.	Designation	On Each Textile Stringer	
		Lateral Load	Longitudinal Load
(1)	(2)	(3)	(4)
i)	Light Special	16	14
ii)	Medium	20	17
iii)	Medium Special	20	17
iv)	Heavy	30	23
v)	Heavy Special	30	23
NOTE — 1 N = 0.102 kg			

The machine is so arranged that the length of traverse of the slide is from 76 to 89 mm in each direction, a to-and-fro movement of 152 to 178 forming a cycle.

The detailed procedure is as follows:

- a) Operate the machine by hand until the slider gripper is in the lowest position, and place in position of the setting pads.
- b) Insert the slider puller between the slider gripper plates, ensuring that any locking device is withdrawn, and engage V-grooves of attachment.
- c) Place the fastener loosely in position in the top tape clamp.
- d) Secure the fastener ends in the bottom tape clamps.
- e) Take hold of the fastener at its top end draw upwards until stop pin prevents further upward movement. Without stretching the tape, tighten the top clamp.
- f) If, while carrying out step (e-1), the fastener is completely closed, then the tape ends that are attached by the bottom tape-clamps are too long. To overcome this, release longitudinal, lateral and top clamps and cut off a length of each bottom tape end. To reassemble start at (c).
- g) Apply the appropriate longitudinal loads by adjusting the spring balances.
- h) Secure lateral clamps to the fastener tapes. There should be gaps of 5 mm between the lateral clamps and the chain at the nearest points. Ensure, that the central lines of the clamps, coincide with the strings which pass over the pulleys. Ensure that the lateral clamps are held firmly against the setting pads whilst securing clamps to the fastener tape, withdraw the setting pads after fixing the clamps.
- j) Apply the appropriate lateral loads by adjusting lateral spring balances.
- k) Set counter to zero, put the machine in motion for one cycle only to equalize the position of the fastener.
- l) Check the loadings of lateral and longitudinal spring balances and adjust when necessary. When the slider is in the lowest position set the adjusting screws 5 mm away from the lateral clamps.
- m) Set the machine in motion at a constant speed. The slider shall make 30 cycles/rein.
- n) Once the test has started, do not readjust the longitudinal and lateral spring balances.
- p) Allow the machine to operate until the specified number of cycles is completed, unless the specimen fails earlier.

ANNEX L

[Table 2, SI No. (ii)]

METHOD OF TESTING THE RESISTANCE TO ABRASION UNDER LOAD

L-1 OUTLINE

Abrasion of the test specimen is caused by movement of abrading material over the interlocking stringer of textile chain.

L-2 APPARATUS

The testing machine which operates on a horizontal plane is constructed on the lines as shown in Fig. 14 and is such as to provide the following facilities:

- a) Means of holding the specimen firmly over a flat surface.
- b) Means of holding abrasive material over the specimen under constant load of 320 g with reciprocating movement and providing means for changing abrasive material after the test.
- c) Providing a drive unit with 60 rpm to be attached to the reciprocating arm with a stroke length of 75 to 90 mm.

L-3 PROCEDURE

A specimen chain length of 200 mm in the closed position is placed flat over the bottom plate and gripped firmly by means of a clamp in such a way that it does not move during testing.

An abrasive emery cloth of designation E80/100/120 (*see* IS 715) of suitable size is cut to grip the abrasive block of the reciprocating arm of the machine. The abrasive block with emery cloth over it is placed over the bottom plate. The drive unit is put to 'on'.

The chain is subjected to abrasion for the number of cycles as required in SI No. (ii) of Table 5 of IS 14181 (Part 1). After completion of the test, when the slider movement over the specimen is tested few times, the operability of the slide fastener shall not be impaired.

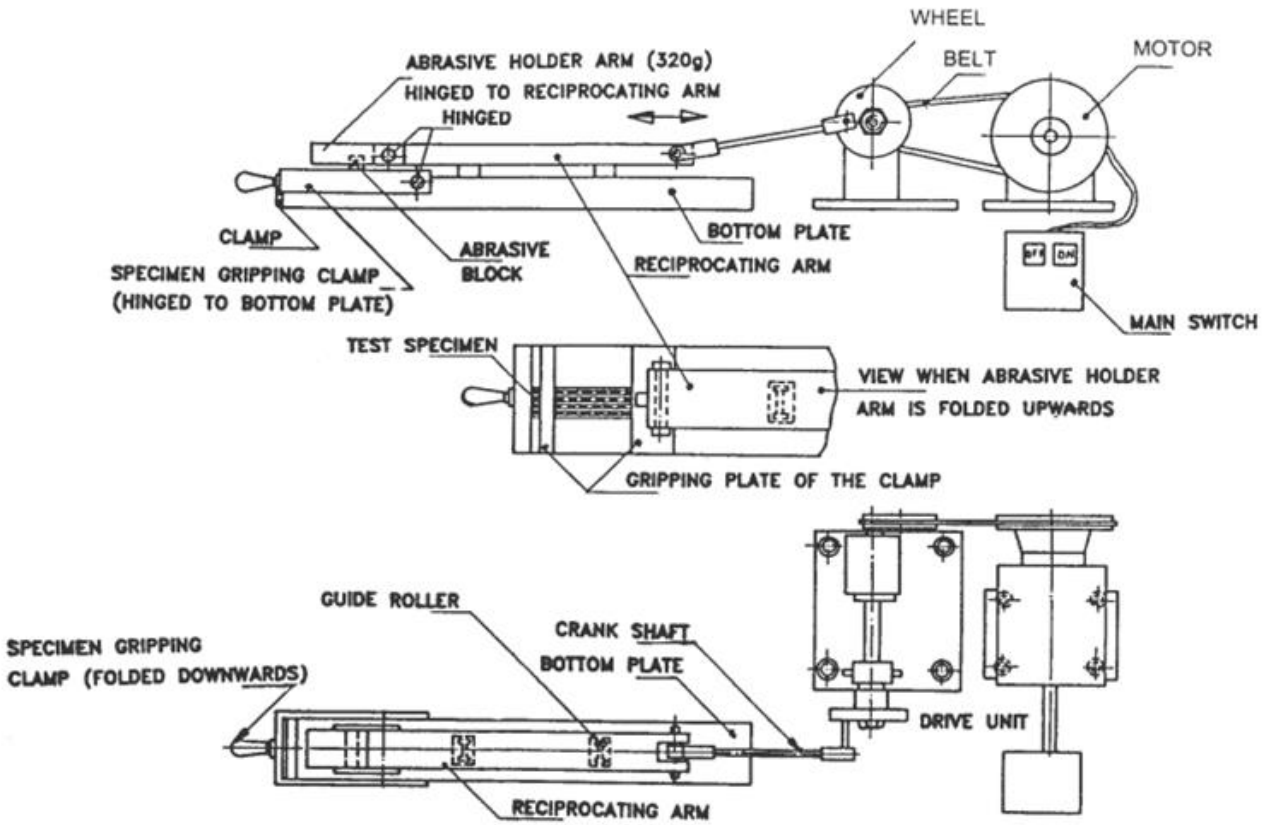

FIG. 14 ABRASION TEST (SCHEMATIC ARRANGEMENT)

ANNEX M

[Table 2, Sl No. (iii)]

METHOD OF TESTING THE RESISTANCE TO HEAT UNDER LOAD

M-1 OUTLINE

Chain is moved under constant load and speed over a heated surface at a given temperature.

M-2 APPARATUS

The testing machine which operates on a horizontal plant is constructed as shown in Fig. 15 so as to provide the following facilities:

- a) Means of holding the specimen firmly in the slide block, which reciprocates over a set of cross bars.
- b) Means of holding a hot plate of 50 mm wide in line with the sliding block. The hot plate is fixed with a thermo couple and temperature indicator of range from 0° to 2000°C.
- c) Providing a drive unit with 60 rpm to be attached to the reciprocating slide block with a stroke length of 75 to 90 mm.

M-3 PROCEDURE

A specimen chain of length 300 mm in the closed position is placed flat over the hot plate. One end of chain is attached to the reciprocating slide block and a constant weight of 750 g is attached to the other end to keep the test specimen in tension, as shown in Fig. 15.

The heater is put on until the temperature reaches 160°C. The machine is started and at the end of 250 cycles the specimen is removed, unless the specimen fails earlier. After completion of the test, when the slider movement over the specimen is tested few times, the operability of the slide fastener shall not be impaired.

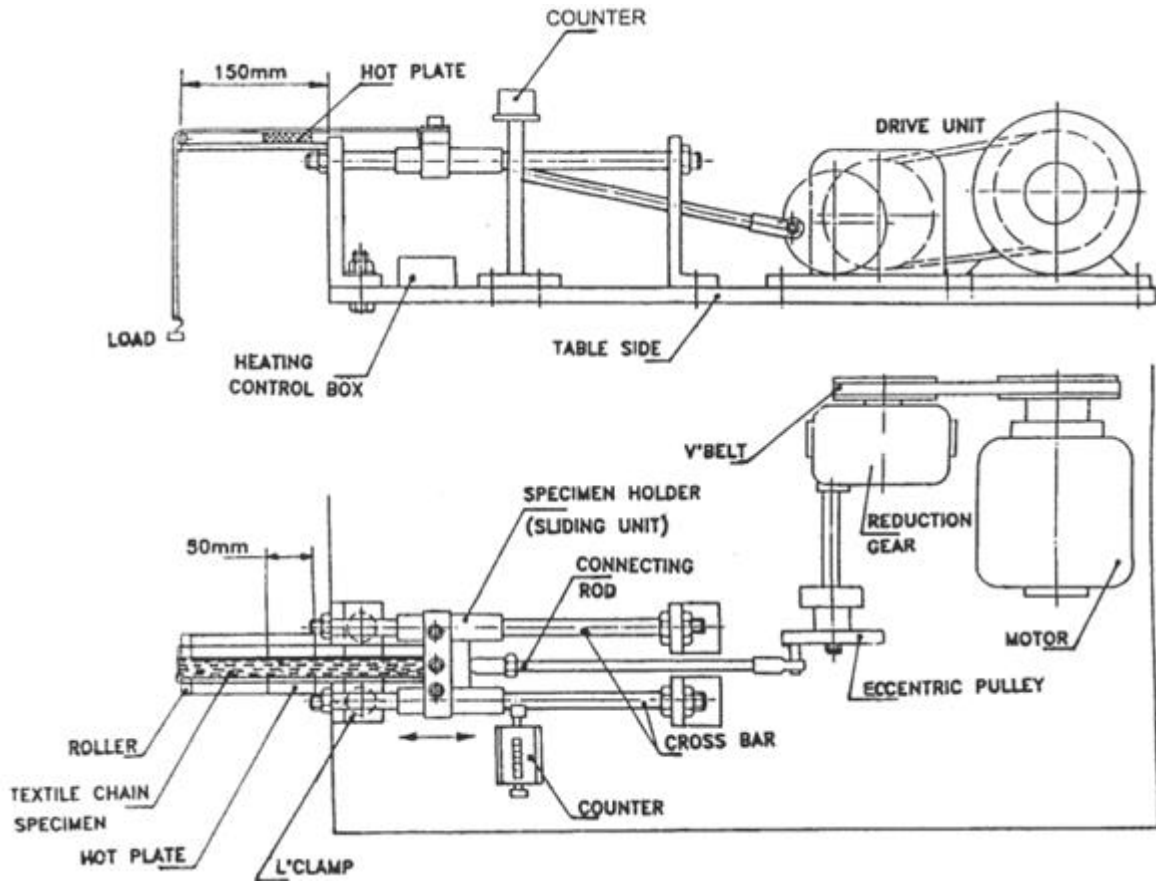

FIG. 15 HEAT RESISTANT (SCHEMATIC ARRANGEMENT)

ANNEX N
[Table 2, Sl No. (iv)]

METHOD OF TESTING REMESHABILITY OF FASTENER

N-1 OUTLINE

If by accident or any reason, the closed interlocking stringer of slider fastener unlocks/opens apart (when the slider is in closed position) excepting by means of slider movement, the opened portion of the interlocking stringer must be able to remesh on slider movement and the functioning of slide fastener is restored.

N-2 PROCEDURE

A reasonable length of slide fastener is taken, its bottom ends is cut or stopper removed, keeping the slider fully closed at top stop. The two stringers from the bottom end are pulled apart to make the stringers open fully up to the slider (*see* Fig. 16). The slider is then moved down and then again upward to interlock the stringer completely. The slider is moved either way few times to check if the slider gets struck and is unable to remesh the chain, the fastener shall be rejected.

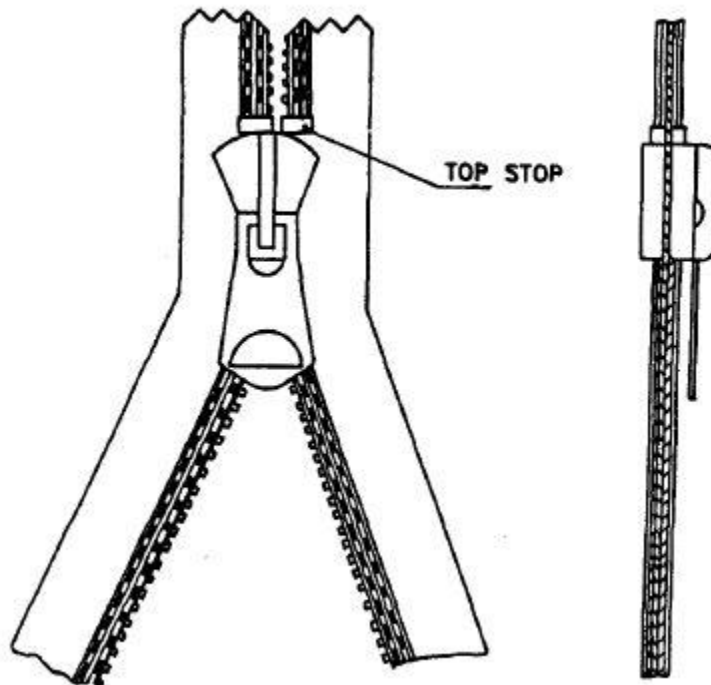

FIG. 16 REMESHABILITY TEST