

BUREAU OF INDIAN STANDARDS
DRAFT FOR COMMENTS ONLY

Not to be reproduced without permission of BIS or used as Standard.

Doc: PGD 13 (26119) WC

July 2024

भारतीय मानक मसौदा
नीडल रोलर बियरिंग्स के लिए केज — विशिष्टि
(IS 4216 का पहला पुनरीक्षण)

Draft Indian Standard

Cages for Needle Roller Bearings — Specification

(First Revision of IS 4216)

ICS 21.100.20

Bearings Sectional Committee, PGD 13

Last date of Comment: 07 Sep. 2024

FOREWORD

(Formal clauses will be added later on)

This standard was first published in 1981. This first revision has been brought out to keep pace with the latest technological developments and international practices.

Needle cages are generally used as a component of rolling bearings assembly offering high load, carrying capacity with reduced cross-sectional areas.

In this revision, the following major modifications have been made:

- a) New clause on references has been added;
- b) Clause on symbols has been introduced, accompanied by a new table;
- c) Two new tables have been incorporated into the dimensions clause;
- d) Clause on tolerances has been added;
- e) Figure 1 has been modified; and
- f) Annex B, Annex C, and Annex D have been added, offering supplementary information referenced in the body of the standard.

In the preparation of this standard, considerable assistance has been derived from ISO 3030 : 2022 “Rolling bearings — Radial needle roller and cage assemblies — Boundary dimensions, geometrical product specifications (GPS) and tolerance values” issued by International Organization for Standards.

The composition of the Committee responsible for the formulation of this standard will be added as Annex E later.

For the purpose of deciding whether a particular requirement of this standard is complied with, the final value, observed or calculated expressing the result of a test or analysis, shall be rounded off in accordance with IS 2 : 2022 ‘Rules for rounding off numerical values (*second revision*).’ The number of significant places retained in the rounded off value should be the same as that of the specified value in this standard.

Draft Indian Standard

CAGES FOR NEEDLE ROLLER BEARINGS — SPECIFICATION

(First Revision of IS 4216)

1 SCOPE

This Standard specifies the requirements for four types of needle cages used as a component of rolling bearings assembly for high load carrying capacity.

2 REFERENCES

The standards given below contain provisions which, through reference in this text, constitute provisions of this standard. At the time of publication, the editions indicated were valid. All standards are subject to revision, and parties to agreements based on this standard are encouraged to investigate the possibility of applying the most recent editions of these standards:

<i>IS No./Other Standards</i>	<i>Title</i>
IS 919 (Part 1) : 2014	Geometrical product specifications (GPS) — ISO code system for tolerances on linear sizes — Part 1: Basis of tolerances, deviations and fits (Third Revision)
IS 919 (Part 2) : 2014	Geometrical product specifications (GPS) — ISO code system for tolerances on linear sizes — Part 2: Tables of standard tolerance classes and limit deviations for holes and shafts (Second Revision)
IS 4215 : 1983	Specification for ring type needle bearings (<i>first revision</i>)
IS 4217 : 2020	Rolling bearings — Needle rollers — Specification (<i>second revision</i>)
IS 4905 : 2015	Random sampling and randomization procedures (<i>first revision</i>)
IS 12160 : 2015	Geometrical product specifications (GPS) — Fundamentals — Concepts, principles and rules (<i>First Revision</i>)
IS 15373 : 2003	Methods for the assessment of departure from roundness — Measurement of variations in radius
IS 16736 : 2020	Rolling bearings — Needle rollers — Boundary dimensions, Geometrical product specifications (GPS) and Tolerance values (<i>first revision</i>)
IS 18229 (Part 1) : 2023	Geometrical product specifications (GPS) — Dimensional tolerancing — Part 1: Linear sizes
IS 8000 (Part 1) : 2019	Geometrical product specifications (GPS) — Geometrical tolerancing (Part 1) — Tolerances of form, orientation, location and run-out (<i>Second Revision</i>)
PGD 13 (24061) / ISO 15241 : 2012	Rolling bearings — Symbols for physical quantities

3 TYPES

Needle cages shall be of the following four types:

- a) Type **B** — Single row of needle rollers;
- b) Type **BB** — Double row of needle rollers;
- c) Type **MB** — Single row of needle rollers, and cage split in two halves; and
- d) Type **MBB** — Double row of needle rollers, and cage split in two halves.

Only for illustration.

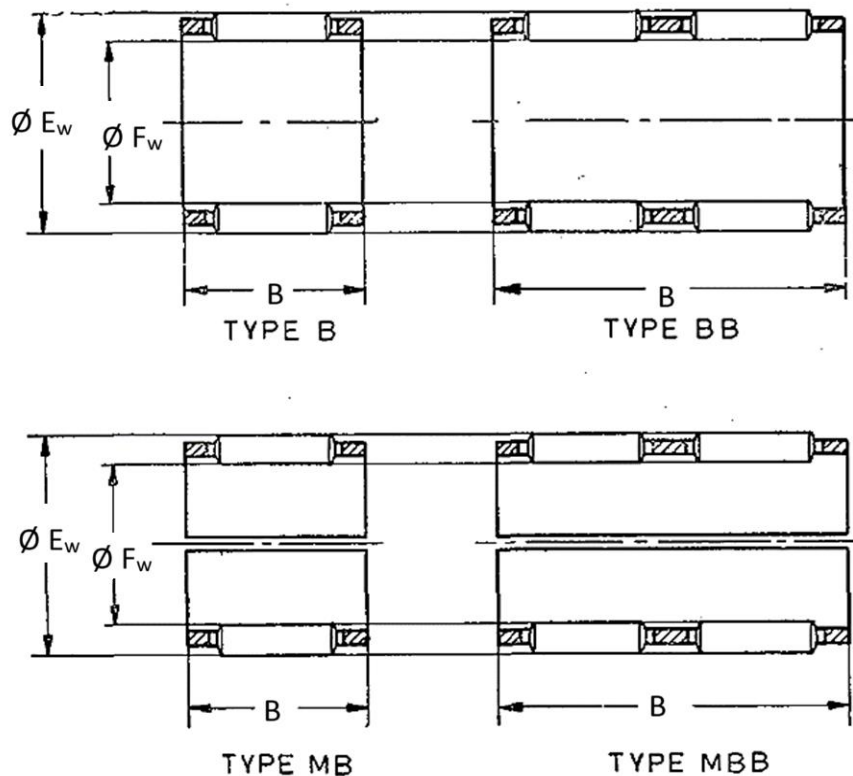

FIG. 1 TYPES OF NEEDLE CAGES

4 DEFINITIONS

4.1 Needle Cage — An assembly of needle rollers held in a cylindrical cage.

5 SYMBOLS

To express that the Geometrical product specifications (GPS) system, IS 12160, is applied, the dimensional and geometrical characteristics shall be included in the technical product documentation (for example, on the drawing).

The dimensional and geometrical specifications associated to these characteristics are described in Table 1 and Fig. 2.

Descriptions for symbols shall be in accordance with GPS terminology.

A tolerance value associated to a characteristic is symbolised by t followed by the symbol for the characteristic, in subscript, for example, $t_{\Delta Bcs}$.

In this document, the GPS default specification operator for size is in accordance with IS 18229 (Part 1).

Table 1 Symbols for nominal sizes, characteristics and specification modifiers

(Clause 5)

Symbol for nominal size ^a	Symbol for characteristic ¹⁾	GPS symbol and specification modifier ²⁾	Description ³⁾
B_c			nominal cage width
	Δ_{Bcs}	(GN)	deviation of minimum circumscribed size of cage width from its nominal size
E_w			nominal circumscribed diameter of needle roller complement
F_w			nominal inscribed diameter of needle roller complement

1) Symbols as defined in ISO 15241 except for the format used.

2) Symbols as defined in IS 18229 (Part 1).

3) Description based on IS 18229 (Part 1).

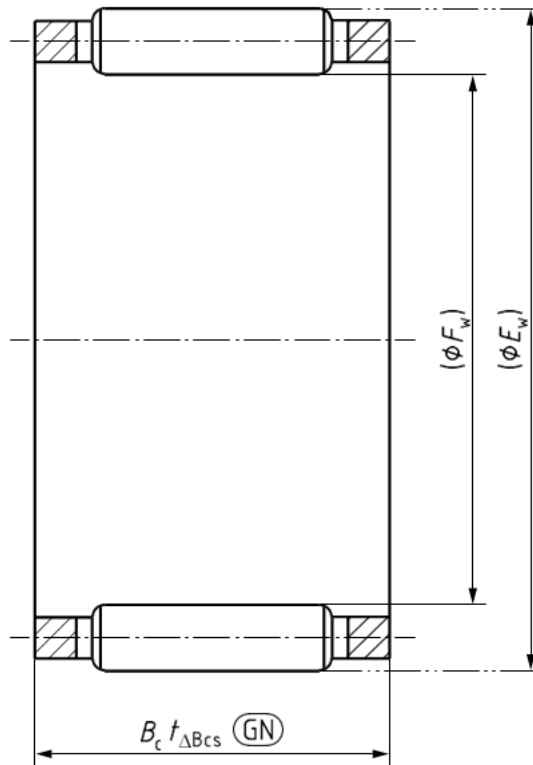

FIG. 2 RADIAL NEEDLE ROLLERS AND CAGE ASSEMBLY

6 GRADE

Needle cages shall be of the following three grades:

- a) Grade I - In this grade, needle rollers shall conform to Grade G2 of IS 16736 : 2020
- b) Grade II - In this grade, needle rollers shall conform to Grade G3 of IS 16736 : 2020
- c) Grade III - In this grade, needle rollers shall conform to Grade G5 of IS 16736 : 2020

The needle roller grade should be as agreed between the customer and manufacturer.

7 MATERIAL

The material for the cylindrical cage may be as agreed between customer and manufacturer. Steel, Brass and Polyamide cages are generally used for cylindrical cages.

8 DIMENSIONS

The general plan of nominal boundary dimensions of needle roller and cage assemblies shall be as given in Tables 2 and 3. For different types of cage assemblies like two row or split type, Table 6 given in Annex B may be referred.

Table 2 Diameter series 1C and 2C
(Clause 8)

All dimensions are in millimeters.

F_w	Diameter series 1C								Diameter series 2C							
	E_w	Dimension series B_c							E_w	Dimension series B_c						
		11C	21C	31C	41C	51C	61C	71C		12C	22C	32C	42C	52C	62C	72C
4	7	6	8	10	—	—	—	—	—	—	—	—	—	—	—	—
5	8	6	8	10	13	—	—	—	9	8	10	13	—	—	—	—
6	9	6	8	10	13	15	—	—	10	8	10	13	15	—	—	—
7	10	6	8	10	13	15	17	—	11	8	10	13	15	17	—	—
8	11	6	8	10	13	15	17	—	12	8	10	13	15	17	20	—
9	12	6	8	10	13	15	17	—	13	8	10	13	15	17	20	—
10	13	6	8	10	13	15	17	—	14	8	10	13	15	17	20	—
12	15	6	8	10	13	15	17	—	16	8	10	13	15	17	20	—
14	18	8	10	13	15	17	20	23	19	10	13	15	17	20	23	27
15	19	8	10	13	15	17	20	23	20	10	13	15	17	20	23	27
16	20	8	10	13	15	17	20	23	21	10	13	15	17	20	23	27
17	21	8	10	13	15	17	20	23	22	10	13	15	17	20	23	27
18	22	8	10	13	15	17	20	23	23	10	13	15	17	20	23	27
20	24	8	10	13	15	17	20	23	25	10	13	15	17	20	23	27
22	26	8	10	13	15	17	20	23	27	10	13	15	17	20	23	27
25	29	8	10	13	15	17	20	23	30	10	13	15	17	20	23	27
28	33	10	13	15	17	20	23	27	34	12	15	17	20	25	30	35
30	35	10	13	15	17	20	23	27	36	12	15	17	20	25	30	35
32	37	10	13	15	17	20	23	27	38	12	15	17	20	25	30	35
35	40	10	13	15	17	20	23	27	41	12	15	17	20	25	30	35
38	43	10	13	15	17	20	23	27	44	12	15	17	20	25	30	35
40	45	10	13	15	17	20	23	27	46	12	15	17	20	25	30	35
42	47	10	13	15	17	20	23	27	48	12	15	17	20	25	30	35
45	50	10	13	15	17	20	23	27	51	12	15	17	20	25	30	35

50	55	10	13	15	17	20	23	27	56	12	15	17	20	25	30	35
55	61	12	15	17	20	25	30	35	62	16	20	25	30	35	40	—
60	66	12	15	17	20	25	30	35	67	16	20	25	30	35	40	—
65	71	12	15	17	20	25	30	35	72	16	20	25	30	35	40	—
70	76	12	15	17	20	25	30	35	77	16	20	25	30	35	40	—
75	81	12	15	17	20	25	30	35	82	16	20	25	30	35	40	—
80	86	12	15	17	20	25	30	35	87	16	20	25	30	35	40	—
85	92	16	20	25	30	35	40	—	93	20	25	30	35	40	45	—
90	97	16	20	25	30	35	40	—	98	20	25	30	35	40	45	—
95	102	16	20	25	30	35	40	—	103	20	25	30	35	40	45	—
100	107	16	20	25	30	35	40	—	108	20	25	30	35	40	45	—

Table 3 Diameter series 3C, 4C and 5C
(Clause 8)

All dimensions are in millimeters

F_w	Diameter series 3C							Diameter series 4C							Diameter series 5C				
	E_w	Dimension series B_c						E_w	Dimension series B_c						E_w	Dimension series B_c			
		13C	23C	33C	43C	53C	63C		14C	24C	34C	44C	54C	64C		15C	25C	35C	45C
6	11	10	13	15	—	—	—	—	—	—	—	—	—	—	—	—	—	—	—
7	12	10	13	15	17	—	—	—	—	—	—	—	—	—	—	—	—	—	—
8	13	10	13	15	17	20	—	14	12	15	17	20	—	—	—	—	—	—	—
9	14	10	13	15	17	20	—	15	12	15	17	20	—	—	—	—	—	—	—
10	15	10	13	15	17	20	—	16	12	15	17	20	—	—	17	16	20	25	—
12	17	10	13	15	17	20	23	18	12	15	17	20	—	—	19	16	20	25	—
14	20	12	15	17	20	25	30	21	16	20	25	30	35	—	22	20	25	30	—
15	21	12	15	17	20	25	30	22	16	20	25	30	35	—	23	20	25	30	—
16	22	12	15	17	20	25	30	23	16	20	25	30	35	—	24	20	25	30	35
17	23	12	15	17	20	25	30	24	16	20	25	30	35	—	25	20	25	30	35
18	24	12	15	17	20	25	30	25	16	20	25	30	35	40	26	20	25	30	35
20	26	12	15	17	20	25	30	27	16	20	25	30	35	40	28	20	25	30	35
22	28	12	15	17	20	25	30	29	16	20	25	30	35	40	30	20	25	30	35
25	31	12	15	17	20	25	30	32	16	20	25	30	35	40	33	20	25	30	35
28	35	16	20	25	30	35	40	36	20	25	30	35	40	45	38	25	30	35	40
30	37	16	20	25	30	35	40	38	20	25	30	35	40	45	40	25	30	35	40
32	39	16	20	25	30	35	40	40	20	25	30	35	40	45	42	25	30	35	40
35	42	16	20	25	30	35	40	43	20	25	30	35	40	45	45	25	30	35	40
38	45	16	20	25	30	35	40	46	20	25	30	35	40	45	48	25	30	35	40
40	47	16	20	25	30	35	40	48	20	25	30	35	40	45	50	25	30	35	40
42	49	16	20	25	30	35	40	50	20	25	30	35	40	45	52	25	30	35	40
45	52	16	20	25	30	35	40	53	20	25	30	35	40	45	55	25	30	35	40
50	57	16	20	25	30	35	40	58	20	25	30	35	40	45	60	25	30	35	40
55	63	20	25	30	35	40	45	65	25	30	35	40	45	50	70	35	40	45	50
60	68	20	25	30	35	40	45	70	25	30	35	40	45	50	75	35	40	45	50
65	73	20	25	30	35	40	45	75	25	30	35	40	45	50	80	35	40	45	50
70	78	20	25	30	35	40	45	80	25	30	35	40	45	50	85	35	40	45	50
75	83	20	25	30	35	40	45	85	25	30	35	40	45	50	90	35	40	45	50
80	88	20	25	30	35	40	45	90	25	30	35	40	45	50	95	35	40	45	50

85	95	25	30	35	40	45	50	100	35	40	45	50	60	—	105	45	50	60	70
90	100	25	30	35	40	45	50	105	35	40	45	50	60	—	110	45	50	60	70
95	105	25	30	35	40	45	50	110	35	40	45	50	60	—	115	45	50	60	70
100	110	25	30	35	40	45	50	115	35	40	45	50	60	—	120	45	50	60	70

9 TOLERANCES

9.1 Tolerances for the needle roller

Tolerances and “gauges” of needle rollers shall be in accordance with IS 16736 : 2020.

9.2 Tolerance for the cage width

The tolerance for cage width, B_c , shall be as given in Table 4.

Table 4 Tolerance for the cage width

(Clause 9.2)

Tolerance values are in millimeters.

B_c	$t_{\Delta Bcs}$	
	Upper deviation limit U	Lower deviation limit L
All widths	- 0.2	- 0.8

10 DESIGNATION

The needle cages shall be designated by the type, the nominal size, grade, tolerance group of the needle rollers and the number of this standard.

Example:

A needle cage of type B having an inscribed diameter 20, circumscribed diameter 24, cage width 10, Grade I, tolerance group of needle rollers (0 -2) shall be designated as:

Needle Cage B20 × 24 × 10 × I (0 -2) IS 4216

11 GENERAL REQUIREMENTS

11.1 The hardness and surface roughness of the rolling tracks of the needle cages on the shaft, or in the housing, shall correspond to the values for the rolling tracks of the inner or outer ring of the needle roller bearing (*see* IS 4215).

11.2 The rolling tracks used with the needle cages may have the following tolerances:

Shaft — h5

Housing — G6

11.3 Needle rollers used with needle cages shall conform to IS 4217 sorted in 2 μ m groups.

11.4 Checking of Needle Cage — The needle cage shall rotate freely when positioned between the housing at minimum tolerance of G6 and shaft at maximum tolerance of h5.

12 WORKMANSHIP AND FINISH

The needle cages shall be free from cracks, flaws, corrosion and other injurious defects.

13 SAMPLING AND INSPECTION

Sampling and inspection shall be as specified in Annex A.

14 PACKING AND MARKING

The needle cages shall be protected from corrosion and suitably packed. The packages shall be marked with designation of the needle cage, grade and tolerance group of the needle rollers used, manufacturer's symbol or trade-mark and batch number/month and year of manufacture.

14.1 BIS Certification Marking

The product(s) conforming to the requirements of this standard may be certified as per the conformity assessment schemes under the provisions of the Bureau of Indian Standards Act, 2016 and the rules and regulations framed thereunder, and the products may be marked with the standard mark.

ANNEX A

(Clause 13)

SAMPLING AND INSPECTION

A-1 LOT — In any consignment, all the needle cages of the same designation and manufactured under similar conditions of production shall be grouped to constitute a lot.

A-2 SAMPLING — The number of needle cages to be selected at random from each lot for inspection shall be as per Table 5. To ensure randomness of selection, methods for random sampling to IS 4905 'Methods for random sampling' shall be followed.

Table 5 Sampling Plan and Criteria for Conformity

(Clauses A-2 and A-4)

Lot Size	Sampling Size	Acceptance Number
Up to 100	5	0
101 to 300	8	0
301 to 500	13	1
501 to 1 000	20	1
1001 and above	32	2

A-3 INSPECTION — The random samples selected as in **A-2** shall be inspected for tolerance, workmanship, free rotation and protection against corrosion as per requirements in this specification. Needle rollers from these samples shall be tested as per IS 4217. Any needle cage failing to meet the requirements for anyone or more of the above characteristics shall be declared as defective.

A-4 CONFORMITY — The lot shall be considered, conforming to the requirements, if the number of defectives is less than or equal to the corresponding acceptance number in Table 5.

ANNEX B
(Informative)

Table 6 Dimensions for different types of Needle Cages
(Clause 8)

All dimensions are in millimeters.

B	BB	MB	MBB	d ₁	d ₀	$b_{-0.55}^{-0.2}$
B 6 × 9 × 8				6	9	8
B 8 × 11 × 10				8	11	10
B 10 × 13 × 13				10	13	13
B 12 × 15 × 13				12	15	13
B 14 × 18 × 13				14	18	13
B 15 × 19 × 13				15	19	13
B 16 × 20 × 13				16	20	13
B 17 × 21 × 15				17	21	15
B 18 × 22 × 13				18	22	13
B 18 × 24 × 21				18	24	21
B 18 × 26 × 16				18	26	16
B 18 × 28 × 16				18	28	16
B 19 × 23 × 13		MB 20 × 23 × 13		19	23	13
B 20 × 24 × 13		MB 20 × 24 × 13		20	23	13
				20	24	13
B 20 × 24 × 17		MB 21 × 27 × 15		20	24	17
B 22 × 26 × 13				21	27	15
				22	26	13
B 22 × 26 × 17		MB 23 × 27 × 15		22	26	17
B 25 × 29 × 13				23	27	15
				25	29	13
B 25 × 29 × 17			MBB 28 × 32 × 24	25	29	17
B 25 × 30 × 20				25	30	20
				28	32	24
B 28 × 33 × 17				28	33	17
B 28 × 33 × 27				28	33	27
B 28 × 34 × 21				28	34	21
B 30 × 35 × 27	BB × 29 × 33 × 30			29	33	30
	BB 30 × 35 × 32			30	35	27
				30	35	32
B 32 × 37 × 17			MBB 31 × 36 × 30	31	36	30
B 32 × 37 × 27				32	37	17
				32	37	27
	BB 32 × 37 × 32			32	37	32
	BB 32 × 37 × 58			32	37	58
	BB 34 × 39 × 45			34	39	45
B 35 × 40 × 17			MBB 35 × 40 × 32	35	40	17
B 35 × 40 × 27				35	40	27
				35	40	32
B 37 × 42 × 17			MBB 35 × 42 × 36	35	42	36
B 37 × 42 × 27				37	42	17
				37	42	27
B 40 × 45 × 17			MBB 37 × 42 × 28	37	42	28
B 40 × 45 × 27				40	45	17
				40	45	27

B 42 × 47 × 17 B 42 × 47 × 27	BB 42 × 47 × 34			42 42 42	47 47 47	17 27 34
B 45 × 50 × 17 B 45 × 50 × 27 B 45 × 52 × 21	BB 45 × 50 × 27			45 45 45	50 50 52	17 27 21
B 47 × 52 × 17 B 47 × 52 × 27 B 48 × 53 × 17				47 47 48	52 52 53	17 27 17
B 50 × 55 × 20 B 50 × 55 × 30 B 50 × 58 × 25				50 50 50	55 55 58	20 30 25
B 55 × 60 × 20 B 55 × 60 × 30	BB 51 × 56 × 33			51 55 55	56 60 60	33 20 30
B 60 × 65 × 20	BB 56 × 64 × 50		MBB 55 × 60 × 54	55 56 60	60 64 65	54 50 20
B 60 × 65 × 30 B 60 × 68 × 25 B 65 × 70 × 20				60 60 65	65 68 70	30 25 20
B 65 × 70 × 30 B 65 × 73 × 25 B 70 × 76 × 20				65 65 70	70 73 76	30 25 20
B 70 × 76 × 30 B 70 × 78 × 25 B 73 × 79 × 20				70 70 73	76 78 79	30 25 20
B 75 × 83 × 30 B 80 × 86 × 20 B 80 × 86 × 30				75 80 80	83 86 86	30 20 30
B 85 × 93 × 30 B 90 × 98 × 30				85 90	93 98	30 30

Annex C
(Informative)

TOLERANCES FOR SHAFT RACEWAY, HOUSING RACEWAY AND RACEWAY WIDTHS

C-1 GENERAL

Proper function of radial needle roller and cage assemblies depends on the features of the housing raceway, the shaft raceway, the raceway width and the axial guidance surfaces.

Table values are informative only and it is possible that they are not suitable for use in applications having certain operating conditions and features. In case of doubt, the bearing manufacturer should be consulted for specific advice.

C-2 RACEWAY HARDNESS

The shaft raceway is hardened and finish ground. The surface hardness shall be at least 670 HV (≈ 58 HRC).

C-3 TOLERANCES FOR SHAFT RACEWAY AND HOUSING RACEWAY

Table 7 and 8 show tolerances for housing raceway and shaft raceway, respectively, suggested for general use and normal operating clearance.

For shaft, housing and guidance design, *see* Fig. 3.

Table 7 Tolerances for housing raceway
(Clause C-3 and D-2)

All dimensions are in micrometers

Nominal housing raceway diameter D_1 mm		Deviation of housing raceway diameter G6 ⁴⁾		Surface roughness parameter $t_{Ra\ max}$	Roundness ^{1), 2)}	Range of variation of mean diameter ^{1), 3)}
>	≤	<i>U</i>	<i>L</i>			
6	10	+14	+5	0.2	IT3	IT5/2
10	18	+17	+6			
18	30	+20	+7			
30	50	+25	+9			
50	80	+29	+10			
80	120	+34	+12	0.3		

¹⁾ The deviation limit relating to the tolerance class and the value of the standard grades are given in IS 919 (Part 1) and IS 919 (Part 2).

²⁾ The roundness is in accordance with IS 8000 (Part 1) and shall be measured using the least squares centre (LSC) method according to IS 15373.

³⁾ Alternative: the cylindricity is in accordance with IS 8000 (Part 1).

⁴⁾ The deviation of housing raceway diameter G6 is in accordance with IS 919 (Part 1).

Table 8 Tolerances for shaft raceway
(Clause C-3)

All tolerance values are in micrometres

Nominal shaft raceway diameter d_1 mm		Deviation of shaft raceway Diameter t_{d1}			Surface roughness parameter $t_{Ra\ max}$	Roundness ^{1), 2)}	Range of variation of Mean diameter ^{1), 3)}
>	≤	Tolerance class	U	L			
3	6	h5	0	-5	0.2	IT3	IT5/2
6	10	h5	0	-6			
10	18	h5	0	-8			
18	30	h5	0	-9			
30	50	h5	0	-11			
50	80	h5	0	-13	0.3		
		g5 ⁴⁾	-10	-23			
80	120	g5	-12	-27			

¹⁾ The deviation limit relating to the tolerance class and the value of the standard grades are given in IS 919 (Part 1) and IS 919 (Part 2).

²⁾ The roundness and cylindricity are in accordance with IS 8000 (Part 1).

³⁾ Alternative: the cylindricity is in accordance with IS 8000 (Part 1).

⁴⁾ For alternate tolerance class g5 for nominal shaft raceway diameter between 51 mm and 80 mm, provide higher clearance; in case of doubt, consult the bearing manufacturer.

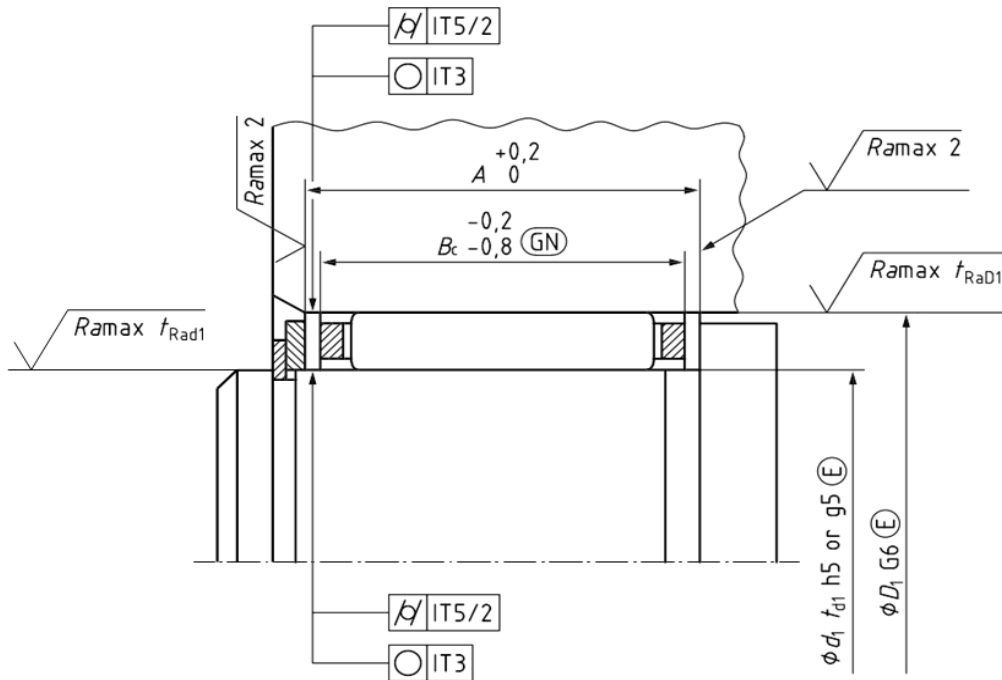

Key

A Nominal distance between axial guidance surfaces equal to B_c

NOTE — An alternative deviation for A is H12.

FIG. 3 SHAFT, HOUSING AND GUIDANCE DESIGN

Annex D

(Informative)

FUNCTIONAL GAUGING OF RADIAL NEEDLE ROLLER AND CAGE ASSEMBLIES

D-1 GENERAL

The bore and outside diameters of the rolling element complement, F_W and E_W , cannot be measured directly. Instead of direct measurement, a functional gauging according to Clause D-2 is applicable.

D-2 FUNCTIONAL GAUGING METHOD

Place the radial needle roller and cage assembly in a ring gauge (*see* Fig. 4, Key 2) having a ring gauge diameter as specified in Table 9.

NOTE — The ring gauge diameter is equal to the lower deviation limit of housing raceway according to Table 7.

Surface roughness, roundness and range of variation of mean diameter of the ring gauge should be in accordance with Table 7.

Insert a plug gauge (*see* Fig. 4, Key 1) that has a dimension equal to the nominal inscribed diameter of the needle roller complement, F_W .

The radial needle roller and cage assembly rotate freely when the ring and plug gauges are rotated relative to each other.

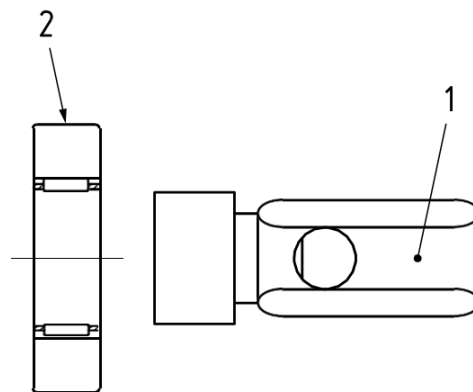

Key

- 1 Plug gauge
- 2 Housing ring gauge

FIG. 4 FUNCTIONAL GAUGE

Table 9 Functional gauge dimensions
(Clause D-2)

All dimensions are in millimeters.

E_w		Functional gauge dimensions	
$>$	\leq	Plug gauge diameter	Ring gauge diameter
—	6	equal to F_w	$E_w + 0.004$
6	10		$E_w + 0.005$
10	18		$E_w + 0.006$
18	30		$E_w + 0.007$
30	50		$E_w + 0.009$
50	80		$E_w + 0.010$
80	120		$E_w + 0.012$