

BUREAU OF INDIAN STANDARDS
DRAFT FOR COMMENTS ONLY
(Not to be reproduced without permission of BIS
or used as an Indian Standard)

Draft Indian Standard

**PLASTIC BOTTLES/CONTAINERS FOR PACKAGING
OF NATURAL MINERAL WATER AND PACKAGED
DRINKING WATER – SPECIFICATION**
(First Revision of IS 15410)

(ICS 55.080; 83.080.20)

Plastics Packaging Sectional Committee,
PCD 21

Last date for comments
16 June 2024

FOREWORD

(Formal clauses to be added later)

This standard covers the requirements for raw materials, dimensional and performance requirements and methods of tests for plastic containers for packaging of natural mineral water and packaged drinking water except flexible pouches, polymeric layers inside metal cans & paperboard-based packaging materials.

Separate Indian Standard exists for:

- a) Plastics containers for other potable water (other than IS 14543 and IS 13428) [see IS 8688: 1988 Plastics potable water containers — Specification (second revision)].
- b) Polyethylene flexible pouches for the packing of natural mineral water and packaged drinking water — Specification (IS 15609: 2005)

This Indian Standard was originally published in 2003. The major modifications / incorporations in this revision are as follows:

- All plastic components are required to follow the extant provisions of PWM Rules and clarifications issued thereto.
- Biodegradable plastics and compostable plastics are not in the scope of this standard.
- Capacities/ quantity/ volumes are amended as per vide Notification GSR. 779(E) dated 2nd November, 2021 of Legal Metrology (Packaged Commodities) Rules, 2011.
- All the amendments published have been incorporated.

In reporting the results of a test or analysis made in accordance with this standard, if the final value, observed or calculated, is to be rounded off, it shall be done in accordance with IS 2: 2022 'Rules for rounding off numerical values (second revision)'.

1 SCOPE

This standard covers the requirements for raw materials, dimensional and performance requirements and method of tests for plastic containers (such as bottles, jars, cups) including closures made of Polyethylene (PE), or Polyethylene terephthalate (PET), or Polypropylene (PP), or Polycarbonate (PC).

2 REFERENCES

The following standards contain provisions, which through reference in this text constitute the provisions of the standards. At the time of publication, the editions indicated were valid. All standards are subject to revision and parties to agreements based on this standard are encouraged to investigate the possibility of applying the most recent editions of the standard indicated below:

<i>IS No.</i>	<i>Title</i>
IS 2798 : 1998	Methods of test for plastics containers (<i>first revision</i>)
IS 3025 (Part 2) : 2019 / ISO 11885 : 2007	Methods of sampling and test (physical and chemical) for water and wastewater : Part 2 Determination of selected elements by Inductively Coupled Plasma Optical Emission Spectrometry (ICP-OES) (<i>first revision</i>)
IS 3025 (Part 4) : 2021	Methods of sampling and test physical and chemical for water and waste water : Part 4 Colour (<i>second revision</i>)
IS 3025 (Part 5) : 2018	Methods of sampling and test (physical and chemical) for water and wastewater : Part 5 Odour (<i>first revision</i>)
IS 3025 (Part 8) : 2023	Methods of sampling and test (physical and chemical) for water and wastewater : Part 8 Taste rating (<i>second revision</i>)
IS 4905 : 2015 / ISO 24153 : 2009	Random sampling and randomization procedures (<i>first revision</i>)
IS 7019 : 1998	Glossary of terms in plastics and flexible packaging excluding paper (<i>second revision</i>)
IS 8747: 1977	Methods of test for environmental Stress-Crack resistance of Blow-Moulded polyethylene containers
IS 8970 : 1991	Aluminium foil laminate for packaging (<i>first revision</i>)
IS 9833 : 2018	List of pigments and colorants for use in plastics in contact with foodstuffs, pharmaceuticals and drinking water (<i>second revision</i>)
IS 9845 : 1998	Determination of overall migration of constituents of plastics materials and articles intended to come in contact with foodstuffs — Method of analysis (<i>second revision</i>)
IS 10146 : 1982	Specification for polyethylene for its safe use in contact with foodstuffs, pharmaceuticals and drinking water
IS 10171 : 1999	Guide on suitability of plastics for food packaging (<i>second revision</i>)
IS 10910 : 1984	Polypropylene and its copolymers for its safe use in contact with foodstuffs, pharmaceuticals and drinking water
IS 12252 : 2017	Polyalkylene terephthalates (PET and PBT) for their safe use in contact with foodstuffs, pharmaceuticals and drinking water (<i>first revision</i>)
IS 13428 : 2005	Packaged natural mineral water — Specification (<i>second revision</i>)
IS 14534 : 2023	Plastics — Recovery and recycling of plastics waste — Guidelines (<i>first revision</i>)
IS 14535 : 1998	Recycled plastics for the manufacturing of the products — Designation
IS 14543 : 2024	Packaged drinking water (other than packaged natural mineral water) — Specification (<i>second revision</i>)
IS 14971 : 2001	Polycarbonate resins for its safe use in contact with foodstuffs, pharmaceuticals and drinking water — Specification
ISO 18856 : 2004	Water quality — Determination of selected phthalates using gas chromatography/mass spectrometry
IS 3025 (Part 65): 2022	Methods of Sampling and Test Physical and Chemical for Water and Wastewater : Part 65 Application of Inductively Coupled Plasma Mass Spectrometry (ICP-MS) — Determination of selected elements including Uranium Isotopes (<i>first revision</i>)

3 TERMINOLOGY

For the purpose of the standard, the definitions given in IS 7019 and the following shall apply.

3.1 Nominal Capacity — The volume of water normally expected to be filled in the container at 27 °C ± 2 °C.

3.2 Brimful Capacity — The volume of water required to be filled in the container completely at 27 °C ± 2 °C.

3.3 Plastics Containers — Plastics containers imply all plastics containers used for packaging of natural mineral water and packaged drinking water except flexible pouches.

4 REQUIREMENTS

4.1 Materials for Primary Packaging

4.1.1 Container

The material used for plastic containers shall be made of polyethylene (PE) conforming to IS 10146 or polyethylene terephthalate (PET) conforming to IS 12252 or polypropylene (PP) conforming to IS 10910 or polycarbonate (PC) conforming to IS 14971.

4.1.2 Closure

4.1.2.1 Closure materials

The container shall be provided with a closure which shall be made either of:

- Aluminium: annealed aluminium sheets coated on inside with food grade lacquering complying with IS 8970.
- Plastic such as High-Density Polyethylene (HDPE) or Polypropylene (PP) or it's combination with any other suitable plastic material (HDPE, Low Density Polyethylene – LDPE, PP)
- Combination of plastics and metal may also be used.

4.1.2.2 Closure colourants

Pigments and colourants used, if any, in the closure shall comply with IS 9833.

4.1.2.3 Sleeves for the closure (optional)

Shrink sleeve made of plastics, either printed or unprinted, may be used over the closure.

4.1.3 Wad

The wad shall be of Expanded Polyethylene (EPE) or any other suitable food grade material compatible with the contents.

4.1.4 Labels, Stickers, Sleeves

Components for display such as but not limited to labels, stickers shall be of materials.

4.1.5 The top lid for glasses/cups shall be of suitable peelable laminate structure, thickness, shape and print as agreed to between the purchaser and the supplier. Aluminium foil of suitable thickness coated with film of olefinic polymers or co-polymers with food grade adhesives shall be used. Polymer film used for coating of aluminium foil shall conform to the relevant standards for its safe use in contact with foodstuffs, pharmaceuticals and drinking water (*see* 4.1).

NOTE — Detachable handle may be provided if agreed between buyer and supplier.

4.2 Design, Shape and Dimensions

The containers shall be of suitable design, shape and required dimensions as agreed to between the purchaser and the supplier.

4.3 Appearance

4.3.1 Appearance is the visual assessment of the container and includes features such as manufacture, workmanship, finish and aesthetics.

4.3.2 The containers shall be manufactured by suitable process adhering to good manufacturing practice (GMP).

4.3.3 The body of the container shall be free from any visual defects like cavities, crevices, flaws, stains, etc.

4.4 Capacity

The container for packing Natural Mineral Water (IS 13428) and Packaged Drinking Water (IS 14543) shall be permitted in all capacities/ volumes/ quantities.

The brimful capacity shall exceed the nominal capacity by a minimum of 1.5 percent when determined by the method prescribed in 5 of IS 2798.

4.5 Wall Thickness

The wall thickness shall be declared by the manufacturer. The tolerance on wall thickness when measured in accordance with 4.5 of IS 2798 shall be – 2 percent of the declared value. No limit to the plus tolerance of wall thickness has been specified.

4.6 Tests

4.6.1 Colour

4.6.1.1 Transparency

The transparency of a container shall:

- a) Not be less than 85 percent in light transmittance for containers of capacity 2L and below
- b) Not be less than 70 percent in light transmittance for containers of capacity above 2L.

Transparency shall be tested in accordance with the method described in Annex A. The addition of colour/pigment is not permitted for making such containers, except under 4.6.1.2.

4.6.1.2 Tint

Optionally a light blue tint may be used to facilitate compliance with the requirements of recycling specified in Plastic Waste Management (Amendment) Rules, 2022 provided it complies with IS 9833 and 4.6.1 above.

4.6.2 Leakage Test

The containers shall pass the test when tested in accordance with 6.1 and 6.2 of IS 2798. The containers may be provided with a support, only for the purpose of keeping them in the up side down position during the test.

4.6.3 Drop Test and Stack Load Test

4.6.3.1 Drop Impact test

The container (upto 15kg or 15L capacity) with the closure when subjected to the drop test according to method 8 of IS 2798 shall not show any sign of cracking, nor will it rupture, nor shall there be any leakage from the walls of the container. For containers larger than 15kg or 15L capacity, the drop height shall be 0.5m. Slight de-shaping of the body shall not render the container unacceptable in the test.

4.6.3.2 Stack Load test

The containers shall be of sound construction and shall not show any cracks or permanent buckling nor cause leakage or reduction in effectiveness of the closure or cause instability in stacks, when subjected to test according to method given in 9 of IS 2798. The total superimposed load along with the load of the flat surface for different sizes of container shall be as given in Table 1.

Table 1 Details of Minimum Stack Load
(Clause 4.6.3.2)

Sl. No.	Nominal Capacity (ml)	Stock load for 4 containers	Load per container (N)	Stack Load for 4 containers (kgf)	Load per container (kgf)
(1)	(2)	(3)	(4)	(3A)	(4A)
1	50	20	5	2.04	0.51
2	60	24	6	2.45	0.61
3	90	36	9	3.67	0.92
4	180	72	18	7.34	1.84
5	250	100	25	10.20	2.55
6	375	150	38	15.30	3.82
7	500	200	50	20.39	5.10
8	600	240	60	24.47	6.12
9	750	300	75	30.59	7.65
10	1000	400	100	40.79	10.20
11	1500	600	150	61.18	15.30
12	1750	700	175	71.38	17.85
13	2000	800	200	81.58	20.39
14	Higher than 2000	1000	250	101.97	25.49

NOTES

1. Column (2A) and (3A) are derived by using conversion factor of 1 N = 0.101972 kgf.
2. Units of measurement (N or kgf) to be decided between buyer and seller.

4.6.4 Migration Tests

4.6.4.1 Overall migration

Representative samples of plastic container and closure shall be subjected to overall migration test with distilled water (Simulant A) as per IS 9845. The maximum extraction values for the samples shall not exceed 10 mg/dm² or 60 mg/L.

4.6.4.2 Specific migration

Representative samples of plastic container and closure shall be subjected to migration test with distilled water (Simulant A) as per test conditions stipulated in IS 9845. The samples shall not release the substances in quantities exceeding the specific migration limits stipulated by Food Safety and Standards (Packaging) Regulations, 2018. The current limits are listed in Table 2.

Table 2 Specific Migration
(Clause 4.6.4.2)

SI No.	Substances	Maximum Migration Limit (mg/kg)	Test Method
(1)	(2)	(3)	(4)
1	Barium	1.00	IS 3025 (Part2)* or IS 3025(Part 65)
2	Cobalt	0.05	-do-
3	Copper	5.00	-do-
4	Iron	48.00	-do-
5	Lithium	0.60	-do-
6	Manganese	0.60	-do-
7	Zinc	25.00	-do-
8	Antimony	0.04	-do-
9	Phthalic acid, bis(2- ethylhexyl) ester (DEHP)	1.50	ISO 18856

NOTE — * The specified elements by using ICP-OES in axial viewing as per IS 3025 (Part 2).

4.6.4.3 Colour migration

In the case of plastic coloured closures and plastic tinted bottles, the colour migrated into distilled water (Simulant A) under exposure conditions of IS 9845 – to be considered as the ‘sample’ – shall not exceed 2 colour units when tested in accordance with IS 3025 (Part 4). If the colour migrated exceeds 2 colour units, such materials are not suitable for food contact applications, even though the extractive value is within the limit (see IS 9833).

4.6.5 Water Potability Test

Packaged natural mineral water and packaged drinking water when stored in containers for 30 days, shall not acquire any unpleasant odour or bitter taste when tested according to the method prescribed in Annex B.

5 MARKING AND PACKING

5.1 Each container/ closure shall be marked with:

- a) an indication of its source
- b) name of material (PET/ PE/ PP/PC) along with its recycling symbol and recycled content as required by IS 14535
- c) a packing slip in each consignment of containers/ closures shall include:
 - 1) Nominal capacity – except for closures; and
 - 2) Batch No. or Code No.

5.2 BIS Certification Marking

Plastic containers conforming to the requirements of this Standard may also be preferably marked/ labelled with Standard Mark, after clearing the appropriate conformity assessment scheme under the provisions of the *Bureau of Indian Standards Act, 2016* and the Rules and Regulations framed thereunder.

5.3 Materials for Secondary Packaging

- a) Preforms, Bottles, closures shall be packed as agreed to between buyer and supplier.
- b) If any secondary packaging is of a plastic then it shall comply with PWM Rules and clarifications issued.

6 SAMPLING

The samples of the containers shall be drawn and the criteria for conformity shall be determined as prescribed in Annex C.

ANNEX A
(Clause 4.6.1.1)

METHOD OF TEST FOR TRANSPARENCY

A-1 GENERAL

Test specimen shall be prepared from the part of container where markings are not found.

A-2 APPARATUS

The optical series principle diagram of integration ball type light transmittance measurement device is shown in Fig. 1 and Fig. 2. The device shall conform to the optical conditions specified in Table 3.

A-3 TEST SPECIMEN

The size of test specimen shall be 50 mm x 50 mm and the thickness shall be the original thickness of the test specimen.

The test specimens shall be prepared.

A-4 MEASUREMENT

A-4.1 Install the white standard plate, adjust the reading (T_1) of the device's current meter to be 100; adjust the amount of incident light.

A-4.2 Under the status where the white standard plate is installed, install and measure the test specimen to obtain the indication (T_2) of the current meter. The full light transmittance shall be calculated according to the following formula:

$$T = \frac{T_2}{T_1} \times 100$$

where

T = full light transmittance, percent.

A-4.3 Transparency test can also be carried out as per 'ASTM D 1003 -Standard Test Method for Haze Transmittance of Transparent Plastics'. In case of dispute, the test method given in ASTM D 1003 shall be used as referee method.

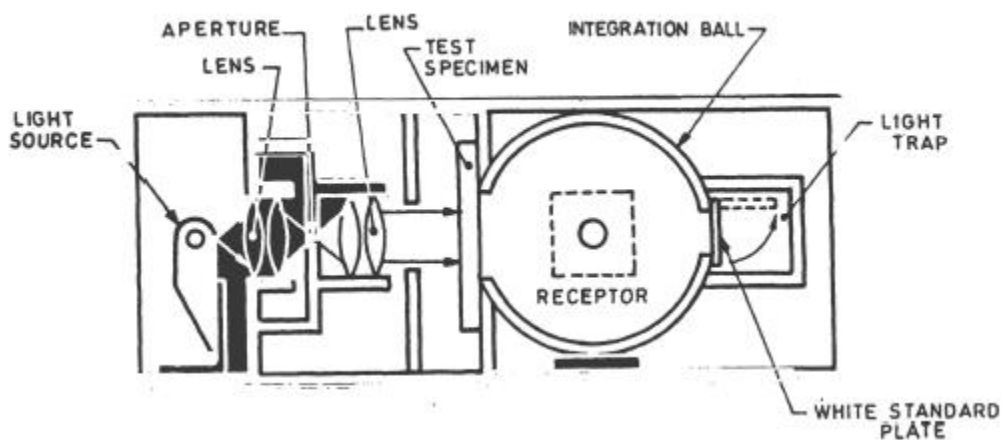

FIG. 1 PRINCIPLE DIAGRAM OF DEVICE

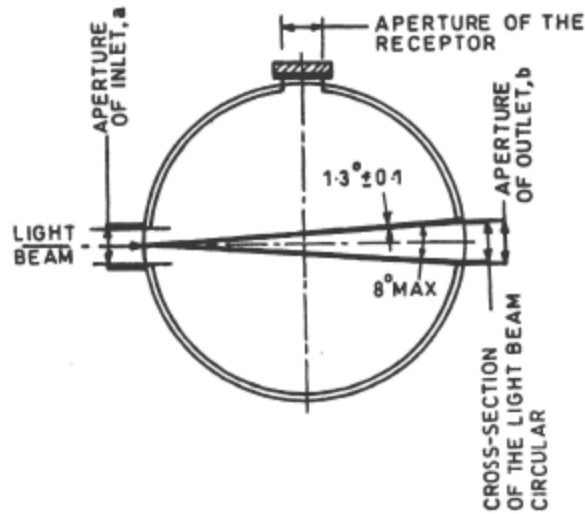

FIG. 2 CONDITIONS OF THE INTEGRATION BALL

Table 3 Optical Conditions of Device
 (Clause A-2)

Sl. No.	Item	Conditions
(1)	(2)	(3)
1	Integration ball	The sum of areas of light's inlet and outlet (the installation part of the test specimen and the white standard plate) (a+b+c) shall be less than 4 percent of the overall internal surface area of the ball (see Fig. 1). The centre line of the outlet and inlet shall be on the same large circle of the ball. The angle formed by outlet diameter and the centre line of the inlet shall be within 8°
2	Reflection surface	The white standard plate shall have same high reflectivity to full wavelength of the visible light. Magnesium oxide, barium sulphate and aluminium oxide, etc, can meet such requirements. The interior of the integration ball shall be coated with a material having the same reflectivity as white standard plate. The light beams used to shine on the test specimen shall be parallel lights. Lights deviated from the optical axis for more than 3° shall not be used. The centre of light beam shall coincide with the centre line of the outlet
3	Light beam	The cross-section of the light beam at the outlet shall be circular and bright; the angle formed by its diameter and the centre of the inlet shall be $1.3 \pm 0.1^\circ$ smaller than the angle formed by the outlet diameter. The cross-section of the light beam at the outlet of the integration ball shall conform to Fig.1
4	Light trap	The light trap when not installed with the test specimen or the white standard plate, shall be able to completely absorb the light
5	Light source	The light source shall be standard light source c The comprehensive sensitivity of the receptor and the visual sensitivity filter used shall satisfy the Y value of Luther
6	Receptor	Conditions at the standard light source c However, when designated specifically, the one which Satisfies the Y value of Luther conditions at the standard light source a can be used.

ANNEX B
(Clause 4.6.5)

METHOD OF TEST FOR POTABILITY

B-1 GENERAL

B-1.1 Odour of water, though very important, cannot be determined in absolute units. Olfactory sense, which is most sensitive means of detecting small concentration of odiferous substances is universally adopted in such cases.

B-1.2 Natural Mineral water or Packaged Drinking Water for testing shall be clear and fresh.

B-2 PROCEDURE

Heat the water to a temperature of $38\text{ }^{\circ}\text{C} \pm 2\text{ }^{\circ}\text{C}$, and fill the container to its nominal capacity and closed tightly with the closure. Keep the container at $38\text{ }^{\circ}\text{C} \pm 2\text{ }^{\circ}\text{C}$, for a period of 30 days. The container shall be opened after 30 days of storage period and the water shall be examined for any disagreeable odour or smell.

B-3 OBSERVATIONS

At the end of the 30 days, the water shall not give any unpleasant odour or taste, when tested as per IS 3025 (Part 5) and IS 3025 (Part 8) respectively.

ANNEX C
(Clause 6)

SAMPLING OF CONTAINERS

C-1 SCALE OF SAMPLING

C-1.1 Lot

In any consignment, all the containers of the same material, size and drawn from a single batch of manufacture shall be grouped together to constitute a lot.

C-1.2 Scale of Sampling

For ascertaining the conformity of the lot to the requirements of this standard, tests shall be carried out for each lot separately. The number of containers to be sampled from a lot shall be in accordance with Table 4.

C-1.3 The containers shall be selected at random from the lot. To ensure the randomness of selection, methods given in IS 4905 may be followed.

C-2 CRITERIA FOR CONFORMITY

C-2.1 Appearance

The sample containers selected as per col 3 of Table 4 shall be examined for manufacture, workmanship, finish and appearance. Any container failing in one or more of the requirements shall be termed as defective. The lot shall be accepted under this head if the number of defective containers in sample does not exceed the acceptance number given in col 4 of Table 4.

Note — Acceptance number means number of failed samples.

C-2.2 Capacity

Five containers for lot size up to 5 000 and ten containers for lot size above 5 000 shall be selected at random from the samples already drawn according to C-1.3 when subjected to capacity test (see 4.4). There shall be no failure, if the lot is to be accepted under this clause.

C-2.3 Transparency, Tint and Leakage

The number of sample containers to be drawn shall be in accordance with col 4 of Table 4. Each of the sample container shall be subjected to transparency (see 4.6.1, and 4.6.1.1) and leakage (see 4.6.2).

The number of failures shall not exceed the acceptance number given in col 6 of Table 4 for transparency and tint test. For leakage test, the acceptance number is zero, that is no failure shall occur for lot acceptance.

C-2.4 Drop Test and Stack Load Test

The sample containers as given in test method (see 4.6.3.1 and 4.6.3.2) shall be drawn from the lot and these shall be subjected to drop test and stack load test. The sample size shall be in accordance with IS 2798. There shall be no rupture or leakage in any container after the test for lot acceptance. In case even one container has any sign of rupture or leakage, the lot shall be considered as not conforming to the requirements of this standard.

Table 4 Scale of Sampling and Acceptance Number
(Clauses C-1.2, C-2.1 and C-2.3)

Sl No.	Lot Size	For Appearance		For Transparency, Tint and Leakage Test	
		Sample size	Acceptance Number	Sample Size	Acceptance Number
(1)	(2)	(3)	(4)	(5)	(6)
1	Up to 500	13	1	5	0
2	501 to 1000	20	2	8	0
3	1001 to 3000	32	3	13	0
4	3001 to 5000	50	5	20	1*
5	5001 and above	80	7	32	2*

* For leakage test the acceptance number is zero, that is no failure shall occur for lot acceptance (*see* C-2.3)