

BUREAU OF INDIAN STANDARDS
DRAFT FOR COMMENTS ONLY
(*Not to be reproduced without permission of BIS
or used as an Indian Standard*)

भारतीय मानक मसौदा

परीक्षण पद्धतियाँ — पॉलीविनाइल क्लोराइड रेजिन
(IS 4669 का पहला पुनरीक्षण)

Draft Indian Standard

METHODS OF TEST — POLYVINYL CHLORIDE RESINS
(*First Revision of IS 4669*)

(ICS 83.080.20)

Methods of Sampling and Test for Plastics
Sectional Committee, PCD 27

Last date for receipt of comment is
14 December 2024

FOREWORD

(*Formal clauses to be added later*)

This standard was originally published in 1968. This revision has been brought out to update the test methods for different parameters as separate Indian Standards are already published for these parameters.

The increase in the use of polyvinyl chloride resins is the result of their unique properties which vary from soft rubber-like products with good tensile and elongation properties to rigid products with high structural modulus and excellent impact resistance. Wide variation in hardness combined with other properties, such as resistance to many chemicals, oxygen and ozone, excellent dielectric strength, fire resistance and ease of processing have promoted their use in a broad range of industrial and domestic applications. These resins are used in the manufacture of wires and cables for electrical purposes, film and sheeting, flooring tiles, PVC coated fabrics (Leather cloth), pipes, injection moulded articles, etc.

In reporting the result of a test or analysis made in accordance with this standard, if the final value, observed or calculated, is to be rounded off, it shall be done in accordance with IS 2 : 2022 'Rules for rounding off numerical values (*second revision*)'.

1 SCOPE

1.1 This standard prescribes methods of test for polyvinyl chloride resins.

2 REFERENCES

The standards listed in Annex A contain provisions which, through reference in this text, constitute provisions of this standard. At the time of publication, the editions indicated were valid. All standards are subject to revision, and parties to agreements based on this standard are encouraged to investigate the possibility of applying the most recent editions of the standards listed in Annex A.

3 TERMINOLOGY

For the purpose of this standard, the definitions given in IS 2828 and the following shall apply.

3.1 K-value — It is obtained from the formula given below:

$$1\ 000 \times \frac{1.5 \log z - 1 + \sqrt{1 + \left(\frac{200}{c} + 2 + 1.5 \log z\right) 1.5 \log z}}{150 + 3 c}$$

where

z = relative viscosity; and
 c = concentration in g/100 ml.

3.2 Viscosity Number — The relative change of viscosity, divided by the concentration in g/100 ml of the dissolved substance.

4 SAMPLING

4.1 Representative sample of the material shall be drawn as prescribed in the relevant material specification.

5 QUALITY OF REAGENTS

5.1 Unless otherwise specified, pure chemicals and distilled water (*see* IS 1070) shall be employed in tests.

NOTE — ‘Pure chemicals’ shall mean chemicals that do not contain impurities which affect the results of analysis.

6 TEST METHODS

For the measurement of properties given in col (2) of Table 1, the methods given in col (3) of Table 1 shall be used.

Table 1
(Clause 6)

SI No.	Properties	Methods of Test, Ref to IS/Annex/Other Standards
(1)	(2)	(3)
i.	Loss in weight on heating/Volatile matter	Annex B/ISO 1269
ii.	Sieve analysis	Annex C/ISO 4610
iii.	Apparent density	IS 13360 (Part 3/Sec 2)
iv.	Viscosity number	Annex D/ISO 1628-2
v.	Electrical conductivity of water extract	Annex E
vi.	Plasticizer absorption number	Annex F/Method A of ISO 4608
vii.	Sulphated ash	Annex G
viii.	Thermal stability by Congo red method	Annex H
ix.	Dry flow of 140 g, sec	Method A of ISO 6186
x.	Inherent viscosity	ASTM D1243
xi.	Apparent viscosity at low shear rates using rotational viscometer at 23 °C with 60 phr plasticizer and 2 h ageing	ISO 2555
xii.	K-value	Clause 3.1/ISO 1628-2
xiii.	Inherent viscosity	ASTM D1243
xiv.	RVCM content	IS 10151/ISO 24538

ANNEX A
(Clause 2)

LIST OF REFERRED STANDARDS

<i>IS No./Other Standards</i>	<i>Title</i>
IS 460 (Part 1) : 2020	Test Sieves — Specification Part 1 Wire Cloth Test Sieves (<i>fourth revision</i>)
IS 460 (Part 2) : 2020	Test Sieves — Specification Part 2 Perforated Plate Test Sieves (<i>fourth revision</i>)
IS 517 : 2020	Specification for methanol (Methyl alcohol) (<i>third revision</i>)
IS 878 : 2008/ISO 4788 : 2005	Laboratory glassware — Graduated measuring cylinders (<i>second revision</i>)
IS 1070 : 2023	Reagent grade water — Specification (<i>fourth revision</i>)
IS 1997 : 2008/ISO 385 : 2005	Laboratory glassware — Burettes (<i>third revision</i>)
IS 2828 : 2019/ISO 472 : 2013	Plastics — Vocabulary (<i>second revision</i>)
IS 10151 : 2019	Polyvinyl chloride (PVC) and its copolymers for its safe use in contact with foodstuffs, pharmaceuticals and drinking water — Specification (<i>first revision</i>)
IS 14421 : 1997	Plasticizer esters — Specification
IS 13360 (Part 3/Sec 2) : 1997/ISO 60 : 1977	Plastics — Methods of testing: Part 3 Physical and dimensional properties Section 2 Determination of apparent density of material that can be poured from a specified funnel

ISO 1269 : 2006	Plastics — Homopolymer and copolymer resins of vinyl chloride — Determination of volatile matter (including water)
ISO 1628-2 : 2020	Plastics — Determination of the viscosity of polymers in dilute solution using capillary viscometers Part 2: Poly(vinyl chloride) resins
ISO 2555 : 2018	Plastics — Resins in the liquid state or as emulsions or dispersions — Determination of apparent viscosity using a single cylinder type rotational viscometer method
ISO 4608 : 2023	Plastics — Homopolymer and copolymer resins of vinyl chloride for general use — Determination of plasticizer absorption at room temperature
ISO 4610 : 2001	Plastics — Vinyl chloride homopolymer and copolymer resins — Sieve analysis using air-jet sieve apparatus
ISO 6186 : 2023	Plastics — Determination of pourability
ISO 24538 : 2008	Plastics — Homopolymer and copolymer resins of vinyl chloride — Determination of residual vinyl chloride monomer by gas-chromatographic analysis of dry powder
ASTM D1243	Standard test method for dilute solution viscosity of vinyl chloride polymers

ANNEX B

[Table 1, Sl No. (i)]

DETERMINATION OF LOSS IN WEIGHT ON HEATING

B-1 PROCEDURE

B-1.1 Weigh accurately about 5 g of the material in a tared weighing bottle of about 50 ml capacity and 50 mm diameter. Place the weighing bottle in an air circulating oven maintained at (105 ± 2) °C with its cover half open for 1 h. Remove the weighing bottle from the oven, put the lid on and cool it to room temperature in a desiccator.

B-1.2 Weigh the bottle again. Carry out this determination three times.

B-2 CALCULATION

$$\text{Loss in weight on heating, percent by weight} = \frac{A-B}{A-C} \times 100$$

where

A = weight in g of the weighing bottle with material before drying;
 B = weight in g of the weighing bottle with material after drying; and
 C = weight in g of the weighing bottle.

B-3 REPORT

The mean of the three determination shall be reported as the representative value of the loss in weight on heating of the material.

ANNEX C
[Table 1, Sl No. (ii)]
SIEVE ANALYSIS

C-1 OUTLINE OF THE METHOD

This method is used to determine the particle size distribution. It is useful for determining lot-to-lot uniformity of polyvinyl chloride resins. This method is applicable to the powdered polymers of vinyl chloride having a particle size larger than 44 microns.

C-2 APPARATUS

C-2.1 Sieve, conforming to IS 460 (Part 1)/ IS 460 (Part 2)

C-2.2 Vibrating device

C-3 PROCEDURE

C-3.1 Weigh accurately about (25 ± 0.01) g of the sample. Transfer the sample into a set of sieves consisting of screens of 250 microns, 200 microns, 150 microns, 100 microns and 75 microns along with a small quantity of carbon black (0.08 g is sufficient). The carbon black helps to eliminate any static electricity. Shake the assembled sieves in the vibrating device for 10 min.

NOTES

- 1) Check the tear or hole of screen of the sieve before test.
- 2) The size of opening of the sieve shall be examined periodically.
- 3) Sieves should be of light construction and 10 cm in diameter to facilitate accurate weighing.

C-3.2 After screening, collect quantitatively the residue on each screen into separate bottles which have been weighed previously, using a funnel and a gentle pat on the wall of the sieve. Weigh the bottles with these residues.

C-4 CALCULATION

C-4.1 The particle size distribution is indicated by the percent quantity retained on each sieve. Let a , b , c , d and e be the percent weight in grams of the residue retained on 250 micron, 200 micron, 150 micron, 100 micron and 75 micron sieves respectively.

- a) Material retained on 250-micron sieve, percent by weight = a
- b) Material retained on 200-micron sieve, percent by weight = $a + b$
- c) Material retained on 150-micron sieve, percent by weight = $a + b + c$
- d) Material retained on 100-micron sieve, percent by weight = $a + b + c + d$

e) Material retained on 75-micron sieve, percent by weight = $a + b + c + d + e$

ANNEX D
[Table 1, Sl No. (iv)]
DETERMINATION OF VISCOSITY NUMBER

D-1 OUTLINE OF THE METHOD

The method of test describes the determination of the viscosity number of a solution in cyclohexanone of polyvinyl chloride resin. The times of flow of the solvent and a solution of resin are measured at 27 °C by conventional methods and the viscosity number is calculated from these measurements and from the known concentration of the solution. Density difference and kinetic energy corrections are small in this method, hence are not applied.

D-2 APPARATUS

D-2.1 Automatic Pipette, 50 ml and 150 ml capacity

D-2.2 Funnel, sintered glass filter funnel No. G 3

D-2.3 Thermostatic Bath, maintained at (27 ± 0.05) °C

D-2.4 Viscometer, suspended-level Ubbelohde type of which the essential dimensions are as shown in Fig. 1. Alternatively, any other viscometer which can be shown to give the same results may be used.

D-2.5 Stop-watch, reading to 0.1 s

D-3 REAGENT

D-3.1 Redistilled Cyclohexanone, the fraction, distilling between 155 °C and 156 °C at a pressure of 760 mmHg, being collected in a brown bottle and stored in the dark.

D-4 PROCEDURE

D-4.1 Clean the viscometer with a mixture of equal volumes of concentrated sulphuric acid and a saturated solution of potassium dichromate in water. Rinse it then with water followed by acetone and dry by drawing through it a stream of air free from dust.

D-4.2 Weigh a quantity of (0.500 ± 0.005) g of resin to the nearest 0.000 2 g and transfer quantitatively to the 50 ml glass-stoppered volumetric flask. Add approximately 40 ml of redistilled cyclohexanone, care being taken to avoid the formation of lumps, and insert the stopper. The mixture is then warmed for $\frac{1}{2}$ h to 1 h at a temperature of 80 °C to 85 °C and occasionally shaken gently until the resin has dissolved. The solution is then cooled to 27 °C and the volume made up to the 50 ml mark.

D-4.3 Filter the liquid through the sintered glass filter funnel directly into Tube A of the viscometer, which should be immersed in the bath maintained at $(27 \pm 0.05) ^\circ\text{C}$, to a depth of approximately 20 mm above the upper graduation mark and supported so that Tube A is vertical. The volume of liquid in the viscometer shall be such that, after draining, the level shall lie between the two filling marks. After not test than 10 min, the liquid is blown with dust-free air or drawn into the upper bulb until it reaches approximately the centre of the bulb. Then place the finger over Tube B until the liquid drops away from the lower end of the capillary.

D-4.4 After removing the finger, measure the time interval for the passage of the meniscus between the two graduation marks. Then blow or draw the liquid into the upper bulb and measure again the time of flow. The time of flow of the solution shall be the mean of the two determinations, which should not differ by more than 0.4 s. The mean time of flow of the redistilled cyclohexanone is determined in the same manner.

D-5 CALCULATION AND EXPRESSION OF RESULTS

$$\text{Viscosity number} = \frac{t - t_o}{t_o C}$$

where

t = time of flow in seconds of the solution;

t_o = time of flow in seconds of the redistilled cyclohexanone; and

C = concentration in g of resin per millilitre of solution.

D-5.1 The viscosity number is reported to the nearest whole number. If the sample has been dried or subjected to any other treatment before test, the details shall also be reported.

D-6 Table 2 provides a chart for interconversion of viscosity number and K-value for one percent solution of PVC in cyclohexanone.

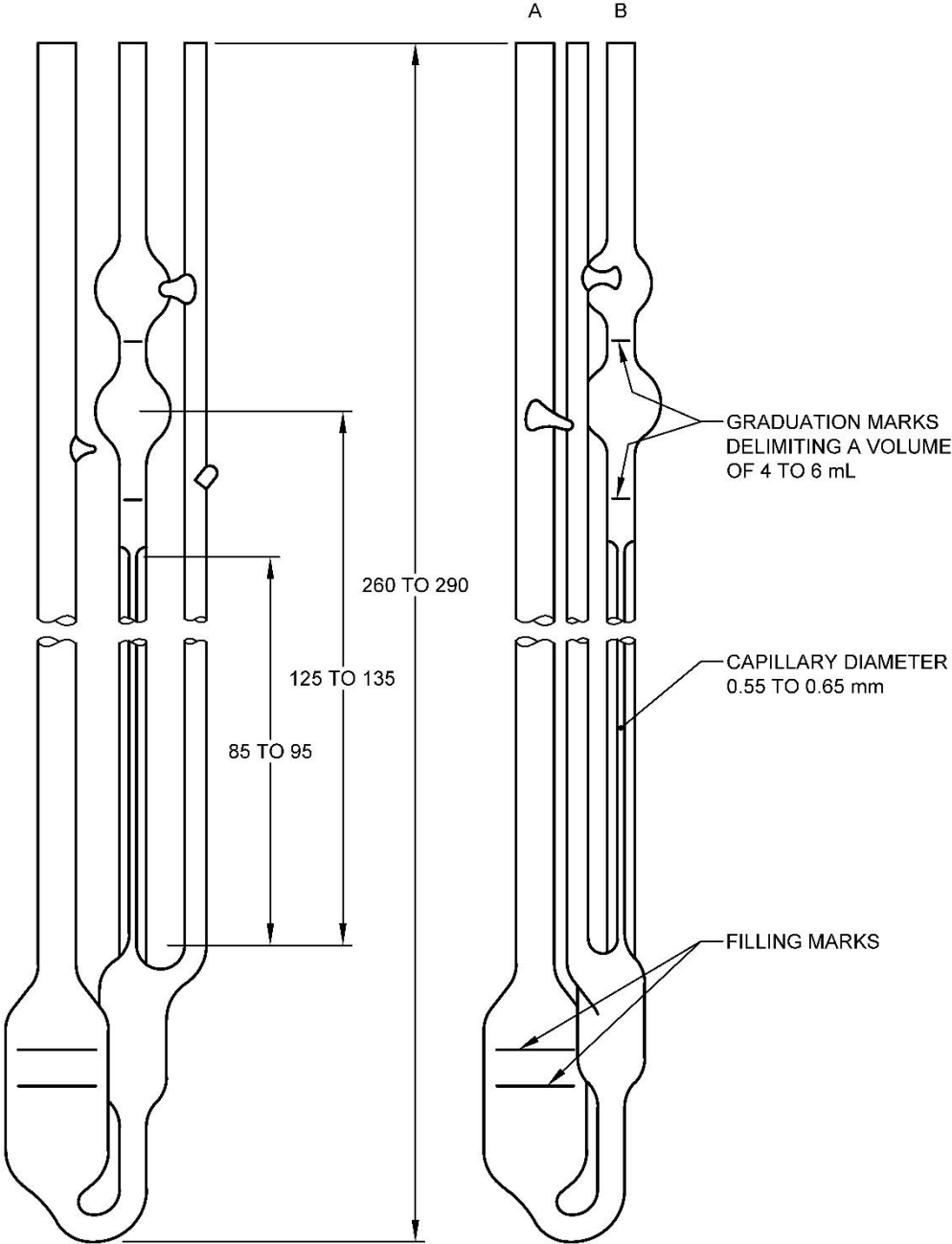

All dimensions in millimetres.

FIG. 1 UBBELOHDE VISCOMETER

Table 2 Interconversion of Viscosity Number and K-value for One Percent Solution of PVC in Cyclohexanone
(Clause D-6)

Viscosity No.	K-value	Viscosity No.	K-value	Viscosity No.	K-value
68	50.11	83	54.75	98	58.75
69	50.43	84	55.03	99	59.00
70	50.76	85	55.31	100	59.25
71	51.09	86	55.59	101	59.49
72	51.42	87	55.87	102	59.74
73	51.74	88	56.14	103	59.98
74	52.06	89	56.42	104	60.22
75	52.37	90	56.69	105	60.46
76	52.67	91	56.95	106	60.69
77	52.97	92	57.21	107	60.93
78	53.27	93	57.47	108	61.17
79	53.57	94	57.74	109	61.40
80	53.87	95	58.00	110	61.63
81	54.17	96	58.25	111	61.85
82	54.46	97	58.50	112	62.07

Viscosity No.	K-value	Viscosity No.	K-value	Viscosity No.	K-value
113	62.29	151	69.71	189	75.63
114	62.51	152	69.88	190	75.77
115	62.73	153	70.05	191	75.91
116	62.94	154	70.22	192	76.05
117	63.16	155	70.39	193	76.19
118	63.38	156	70.56	194	76.32
119	63.60	157	70.73	195	76.46
120	63.81	158	70.90	196	76.60
121	64.02	159	71.07	197	76.73
122	64.23	160	71.23	198	76.87
123	64.44	161	71.40	199	77.00
124	64.64	162	71.56	200	77.13
125	64.84	163	71.71	201	77.27
126	65.04	164	71.87	202	77.40
127	65.25	165	72.03	203	77.53

128	65.45	166	72.18	204	77.66
129	65.65	167	72.34	205	77.79
130	65.85	168	72.50	206	77.92
131	66.04	169	72.66	207	78.05
132	66.24	170	72.82	208	78.18
133	66.44	171	72.97	209	78.31
134	66.63	172	73.12	210	78.44
135	66.82	173	73.27	211	78.57
136	67.00	174	73.42	212	78.70
137	67.19	175	73.57	213	78.83
138	67.38	176	73.73	214	78.95
139	67.57	177	73.88	215	79.08
140	67.75	178	74.03	216	79.20
141	67.93	179	74.18	217	79.32
142	68.11	180	74.32	218	79.45
143	68.30	181	74.47	219	79.57
144	68.48	182	74.62	220	79.70
145	68.66	183	74.76	221	79.82
146	68.84	184	74.91	222	79.94
147	69.02	185	75.06	223	80.06
148	69.20	186	75.20		
149	69.37	187	75.35		
150	69.54	188	75.49		

ANNEX E

[Table 1, Sl No. (v)]

DETERMINATION OF ELECTRICAL CONDUCTIVITY OF WATER EXTRACT

E-1 OUTLINE OF THE METHOD

This test is intended to distinguish between electrical and non-electrical grades of unprocessed resin. A water dispersion of the resin is prepared and the electrical conductivity of the suspension is measured. The conductivity of the water extract results from ionic impurities in the resin which adversely affects its use for electrical insulation.

E-2 APPARATUS

E-2.1 AC Wheatstone Bridge, having a range up to 250 000 ohms, a (1 000 ± 50) cycle oscillator, and a sensitive null point indicator, with minimum accuracy ± 2 percent.

E-2.2 Conductivity Cell, having a cell constant of about 0.5 reciprocal centimetre (0.5 cm^{-1}).

E-2.3 Wide-Mouthed Flat Bottomed Flask with Ground-Glass Stopper, 250 ml capacity

E-2.4 Measuring Cylinders, 10 ml and 100 ml capacity (*see* IS 878)

E-3 REAGENTS

E-3.1 High Purity Water, having a conductivity of not more than 2.5 micro-ohms per cm.

E-3.2 Methanol, *see* IS 517

E-4 PROCEDURE

Weigh accurately about 5 g of the material, to the nearest 0.01 g and transfer it to a wide-mouthed flat bottomed flask with ground glass-stopper which has been previously rinsed twice with high purity water. Add 10 ml of methanol in the flask and swirl the mixture until the resin is uniformly wet. Add 90 ml of high purity water in the flask and close the flask with the stopper. Allow the resulting suspension to stand at $(27 \pm 1) \text{ }^\circ\text{C}$ for 24 h with frequent shaking. Measure the conductivity of the suspension without filtration. Make blank determination using 10 ml of methanol and 90 ml of high purity water. Subtract the blank value from the value of the conductivity of the suspension. Carry out the determination in duplicate.

E-5 REPORT

The mean of the two determinations shall be taken as the representative value of the electrical conductivity of the water extract and shall be expressed in micro-ohms per centimetre. If the variation between the two values is more than ± 5 percent, then discard the values and repeat the test.

ANNEX F

[Table 1, Sl No. (vi)]

DETERMINATION OF PLASTICIZER ABSORPTION NUMBER

F-1 OUTLINE OF THE METHOD

This method covers the measurement of the amount of plasticizer that a resin can absorb at $(27 \pm 2) \text{ }^\circ\text{C}$. Plasticizer absorption is one of the parameters for judging the dry blending properties of a resin.

F-2 APPARATUS

F-2.1 Burette, 10 ml capacity (conforming to class A of IS 1997)

F-2.2 Glass or Glazed Porcelain Tile, about $250 \text{ mm} \times 250 \text{ mm} \times 6 \text{ mm}$ size

F-2.3 Mould, aluminium or brass, as shown in Fig. 2.

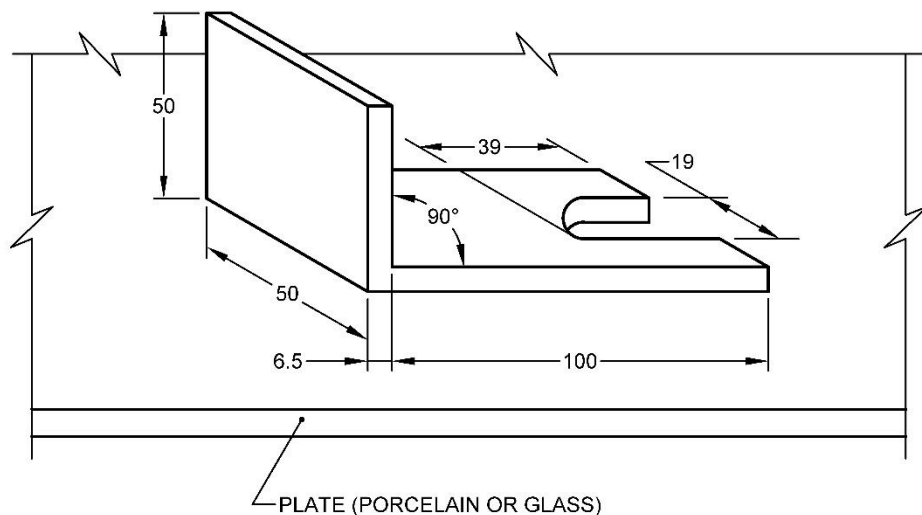

NOTE - TOLERANCE ON ALL DIMENSIONS SHALL BE ± 0.2 mm.

All dimensions in millimetres.

FIG. 2 MOULD FOR PLASTICIZER ABSORPTION TEST

F-2.4 Stainless Steel Spatula, with width and shape to fit mould cavity (*see* Fig. 2).

F-3 REAGENT

F-3.1 Plasticizer, di-2-ethyl-*n*-hexyl phthalate (DOP), with a density of 0.986 g/ml at 27 °C (*see* IS 14421).

F-4 PROCEDURE

Fill the burette with the plasticizer to the zero mark. Weigh (5.00 ± 0.01) g of the material and transfer it to the glass or glazed porcelain tile. Begin adding the DOP to the material from the burette in 0.5 ml increments using the spatula to distribute the plasticizer uniformly in the resin. Continue adding plasticizer till the mass shows indication of becoming fluid. At this stage reduce the rate of addition of plasticizer to 0.05 ml at a time and make consistency determination until the end point is reached. The consistency determination is done by filling the mould, as it rests on the plate, with a mixture and then sliding the spatula under the charge. The charge is lifted above the mould cavity with a spatula horizontal and the blade then rotated to a vertical position. The end point is reached when the mixture first slides off the blade. Carry out the determination in duplicate.

F-5 CALCULATION

Plasticizer absorption, parts per hundred (phr) = $19.7 \times v$

where

v = the total volume in ml of DOP plasticizer used in the test.

F-6 REPORT

The mean of the two determinations shall be reported as the plasticizer absorption number of the material.

ANNEX G

[Table 1, Sl No. (vii)]

DETERMINATION OF SULPHATED ASH

G-1 OUTLINE OF THE METHOD

The material is ignited in a muffle furnace after wetting with sulphuric acid.

G-2 REAGENT

G-2.1 Concentrated Sulphuric Acid, reagent grade

G-3 PROCEDURE

Weigh accurately about 1 g to 2 g of the test sample in a porcelain crucible of about 30 ml capacity, tared to constant weight after ignition at about 800 °C in a muffle furnace. Add the minimum possible quantity of concentrated sulphuric acid necessary to wet the sample, evenly close the cover of the crucible and heat on the sand bath. After cracking and carbonization is over (*see Note*), put the crucible in a muffle furnace for ignition at 800 °C for 2 h. After ignition, cool the crucible to room temperature in a desiccator and weigh to a constant weight.

NOTE — Carbonization is required before ignition since an explosive combustion takes place if the crucible is put in a furnace immediately after addition of sulphuric acid.

G-4 CALCULATION

$$\text{Ash content, percent by weight} = \frac{C - A}{B - A} \times 100$$

where

A = weight in g of the empty tared crucible;

B = weight in g of the crucible with the sample; and

C = weight in g of the crucible with the residue after ignition.

ANNEX H

[Table 1, Sl No. (viii)]

DETERMINATION OF THERMAL STABILITY BY CONGO RED METHOD

H-1 OUTLINE OF THE METHOD

By thermal stability or thermal life of a resin of vinyl chloride polymer is meant the time, in minutes, from the moment at which the material is exposed to a given temperature until the first sign of decomposition is observed. The mode of decomposition is the splitting off of hydrochloric acid. In this, the sample is heated in an oil bath to a specific temperature and the time taken for the vapours to cause a colour change in Congo red paper is noted.

H-2 APPARATUS

H-2.1 Test Tubes, of diameter (16 ± 0.1) mm, wall thickness (0.4 ± 0.2) mm and length at least 150 mm.

H-2.2 Glass Tubes, 2 mm to 3 mm in internal diameter and about 100 mm in length.

H-2.3 Oil Bath, fitted with stirrer and a thermostatic control, capable of maintaining the temperature within ± 1 °C in the range from 120 °C to 210 °C. The bath shall also be fitted with suitable clamps for holding a sufficient number of test tubes immersed to a depth of 50 mm.

H-3 REAGENT

H-3.1 Congo Red Indicator Paper Strips, 10 mm wide. The indicator paper is prepared by immersing strips of filter paper in a 0.15 percent solution of Congo red in methanol (*see* IS 517), and drying them.

H-4 PROCEDURE

H-4.1 For each sample, at least two determinations shall be carried out in two separate test tubes, which shall be immersed in the oil bath at the same time. The preferred temperature of the oil bath is (180 ± 1) °C. Other temperatures may be used provided that the duration of the test is not less than 20 min and not more than 5 h.

H-4.2 Place the sample in the test tube and gently shake it down, taking care to ensure that the pieces do not form a compact mass. Close the test tube with a cork having at its centre the glass tube with a Congo red paper strip 30 mm long and 10 mm wide. The Congo red strip is folded or rolled at one end, which is inserted into a glass tube. The tube is made to slide in such a way that the lower edge of the paper is placed 25 mm above the top of the specimen. Immerse the test tube thus prepared in the oil bath which is already brought to the given temperature, up to the level of the upper surface of the sample.

H-4.3 The time, in minutes, from the insertion of the test tube in the hot oil to the time when the indicator paper shows the first clear signs of a change from red to blue, is recorded. Sometimes, with certain stabilizers in the sample, the colour change is only slow and not very distinct; in these cases, two different times shall be recorded, corresponding to the first sign of colour changing from red to violet and to the permanent change from violet to blue.

H-5 REPORT

H-5.1 Report the mean of the two determinations.

H-5.2 The report shall include the following information:

- a) The complete identification of the material tested and, if desired, the formulation of the compound and the thermal treatment during the preparation of the test specimens;
- b) Test temperature; and
- c) The time before the colour change of the indicator paper, as specified under **H-4.3** or in the case of a slow change of colour, the two different times as specified under **H-4.3**.