

## भारतीय मानक ब्यूरो

**DRAFT FOR WIDE CIRCULATION**

*(Not to be reproduced without permission of BIS or used as an Indian Standard)*

*भारतीय मानक मसौदा*

**सतत पुशर टाइप के कोयला/तेल/गैस ऊपरी तपत रीहीटिंग भट्टियों के डिज़ाइन एवं  
निर्माण संबंधी दिशानिर्देश**

*(आईएस 17082 का पहला पुनरीक्षण)*

*Draft Indian Standard*

**Guidelines for Design and Construction of Continuous Pusher Type Coal  
/Oil/Gas Top Fired Reheating Furnaces**  
*(First Revision of IS 17082)*

ICS 25.180

Industrial Fuel-Fired Furnaces  
Sectional Committee, MTD 26

Last date of comment:  
01/05/2024

### FOREWORD

*(Formal clauses will be added later)*

This standard was originally published in 2019. While reviewing this standard, in the light of experience gained during these years, the Committee decided to revise the standard to keep pace with the latest technological developments.

Pusher hearth furnace is most widely used for continuous reheating of steel billets/ingots/slabs/plates for the purpose of rolling.

In this revision, the following changes have been made:

- Title of the standard has been modified by incorporating coal as fuel in addition to oil and gas;
- Minor changes have been incorporated in Construction details and range of heating rates are added;
- Mode of firing and heat distribution sub clauses which were earlier under Blowers clause have been incorporated under Combustion clause. Also, subclause 6.4 on coal firing system has been added;
- The gas train components clause has been merged with Combustion clause;
- Subclause 7.3 on Pulverized Coal Transportation Blower have been added;

Main reasons for formulating standard of pusher hearth furnace are to appraise the purchaser about the general description with broad specification of a continuous pusher type coal/oil/gas top fired reheating furnaces and the input to be specified for designing the furnace. However, purchaser has the option to further improve upon the specification as per their specific choice/requirement.

For the purpose of deciding whether a particular requirement of this standard is complied with the final value, observed or calculated, expressing the result of a test or analysis, shall be rounded off in accordance with IS 2 : 2022 'Rules for rounding off numerical-values (*second revision*)'. The number of significant places retained in the rounded off value should be the same as that of the specified value in this standard.

*Draft Indian Standard*

**GUIDELINES FOR DESIGN AND CONSTRUCTION OF CONTINUOUS PUSHER TYPE  
COAL /OIL / GAS TOP FIRED REHEATING FURNACES**

*(First Revision)*

## 1 SCOPE

This Indian Standard covers the general guidelines for design and construction for coal/ oil/ gas fired continuous pusher type top fired reheating furnace.

## 2 REFERENCES

The standards listed below contain provisions which, through reference in this text, constitute provisions of this standard. At the time of publication, the editions indicated were valid. All standards are subject to revision, and parties to agreements based on this standard are encouraged to investigate the possibility of applying the most recent editions of the standards are indicated below:

<i>IS No.</i>	<i>Title</i>
IS 5 : 2007	Colours for ready mixed paints and enamels ( <i>sixth revision</i> )
IS 6 : 1983	Specification for moderate heat duty fireclay refractories, group ‘A’ ( <i>fourth revision</i> )
IS 8 : 1994	High heat duty fireclay refractories — Specification ( <i>fifth revision</i> )
IS 2062 : 2011	Hot rolled low, medium and high tensile structural steel — Specification ( <i>seventh revision</i> )
IS 6533	Code of practice for design and construction of steel chimney
(Part 1) : 1989	Mechanical aspects ( <i>first revision</i> )
(Part 2) : 1989	Structural aspect ( <i>first revision</i> )

## 3 DESIGN PARAMETERS

The following basic performance parameters need to be specified for designing of continuous pusher type reheating furnace:

*Material to be charged*..... : **Billets/ Blooms/ Ingot / Slabs**  
*Material specification* ..... : **Mild Steel/ Low or Medium or  
High Carbon Steel / Alloy steel /  
Stainless Steel**

a) *Material dimensions (range)*

*Length* : upto 12 m

*Cross-section*: 130 mm optimum thickness, width can vary

b) *Reference charge material dimensions and material specification on the basis of which  
Furnace will be sized and designed*

*Specification* : .....

*Length* : .....

*Cross-section* : .....

- c) *Straightness of charge material*..... : .....
- d) *Rhomboidity of charge material*..... : .....
- e) *Twist of charge material* : .....
- h) *Number of charging rows*.....: **Single /double**
- i) *Material charge temperature in °C* : Cold charge at ambient temperature/Hot at temp range
- j) *Reference charge material of Charge temperature in °C* : .....°C  
Ambient/20°C
- k) *Material discharge temperature in °C (reference)* : .....
- m) *Material discharge temperature range in °C* : .....
- n) *Discharge Temperature uniformity in the material in °C that is, temperature difference between top & bottom surface of hot billet in °C (required)* :.....
- p) *Combustion air preheated temperature °C* : .....
- q) *Flue gas outlet temperature after waste heat Recovery* : .....
- r) *Furnace output in MT per hour on continuous production for reference size charge at reference conditions in required number of charging row (Single/double)* : .....
- s) *Fuel to be used* : Coal/ Pulverized coal/Furnace oil/LDO/HSD Gas (Natural Gas/ LPG/Coke Oven Gas/Producer gas /other fuel)/Gas with composition
- t) *LCV of fuel in case of coal firing* : .....kCal/Kg.
- u) *LCV of fuel in case of oil firing* : .....kCal/kg
- v) *LCV of Coal*
- w) *in case of gas firing* : ..... kCal/Nm<sup>3</sup>
- x) *Supply temperature and pressure* : .....
- y) *Estimated specific fuel consumption in Million KCal/MT or KJ/Kg on continuous and normal*

	<i>operation for rated output, for reference charge material, under specified reference condition and number of charging rows (to be indicated by the furnace designer)</i>	:	.....
z)	<i>Estimated connected heat load in Million kCal/hr or kW (to be indicated by the furnace designer)</i>	:	.....
aa)	<i>Type of charging</i>	:	Whether side/end charging
bb)	<i>Type of discharging</i>	:	Whether side/end discharging
cc)	<i>Type of flue outlet (down take or uptake)</i>	:	.....
aa)	<i>Electricity supply characteristic for various motors, heaters and controls/instruments.</i>	:	.....
ab)	<i>Compressed air quality with its pressure and temperature</i>	:	.....
ac)	<i>Water quality with its pressure and temperature</i>	:	.....

NOTE — 1 K Cal = 4.186 KJ

$$1 \text{ K Cal/h} = 1.163 \times 10^3 \text{ KW}$$

#### 4 GENERAL CONSTRUCTION

**4.1** The furnace will be generally designed for end charging and side/end discharging arrangement (*see* Fig. 1). The material will be brought in front of the charge door through charge rollers, or directly placed on the charge table. For proper dispositioning of the material at the charge end, in single/double row, fixed and vanishing stopper arrangement will be used when charge approach rollers are used. The material will be pushed by means of hydraulically/electro-mechanically operated pusher mechanism. After the material have reached the discharge end, the same will be taken out one by one from the side by a hydraulically/ electrically operated discharge ejector mechanism. The furnace charge table with billet positioning may be provided.

In case of an end discharge type furnace (*see* Fig. 2), the material will get discharged through the end door one by one over an inclined slope refractory bed on to discharge rollers.

**4.2** Type of material discharging arrangement will be either from side with the help of discharge ejector machine or through end over inclined slope refractory bed on to discharge rollers. However, side discharge with the help of an ejector machine is preferred since during end-discharging, the discharge door through the width of the furnace will remain open and heat losses will increase considerably.

**4.3** The furnace will be equipped with coal/oil burners/gas burners or dual fuel burners, as per customer's requirement especially suitable for steel reheat furnaces which can easily handle air preheat temperature up to preferably 350 °C and above.

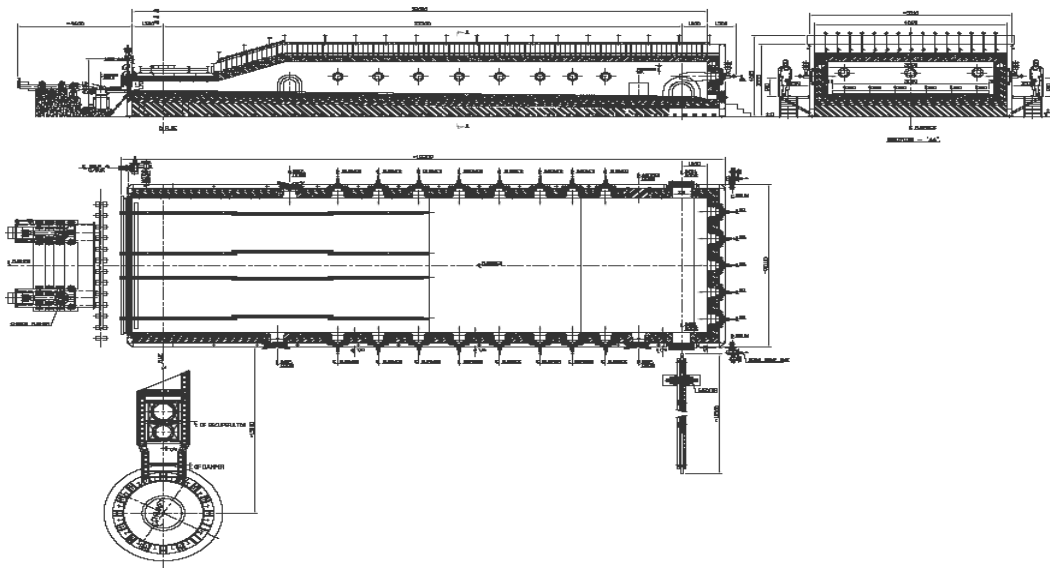

Fig. 1 TYPICAL DIAGRAM END CHARGING AND SIDE DISCHARGING ARRANGEMENT

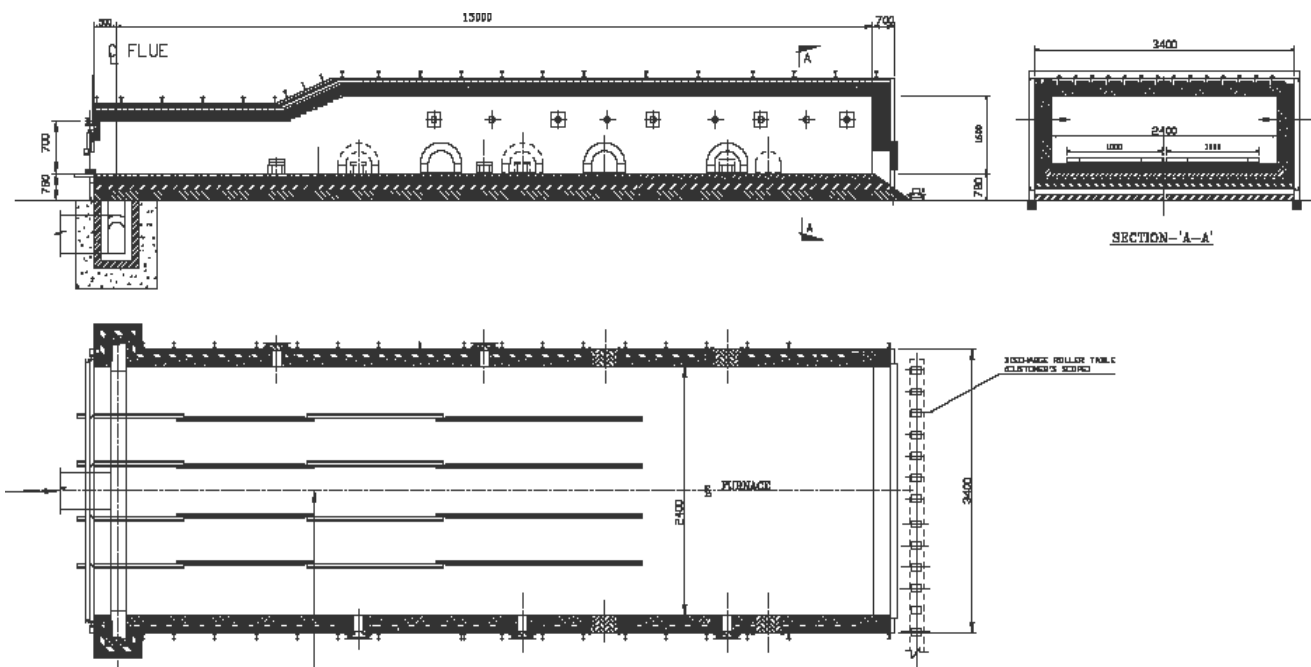

Fig. 2 TYPICAL DIAGRAM END CHARGING AND END DISCHARGING ARRANGEMENT

4.4 Hot gases after passing through the furnace will escape through the flue port located at the charge end. Flue ports will be connected to an overhead/underground flue collector and thereafter pass through the recuperator to the chimney. In the flue duct there will be a recuperator for combustion air preheat. Flue duct from furnace to chimney may be underground or over ground depending on site and soil conditions and layout. In case of probable water seepage below ground level, it is better to use an over ground flue duct from furnace to chimney.

**4.5** The furnace will be divided in heating and soaking zones and the length of the furnace including unfired, heating and soaking zones is to be decided on the basis of heating and soaking time required for the material inside the furnace from charging to discharging to achieve uniformity of temperature and maximum capacity of the furnace.

**4.6** The furnace will be provided with convection type multi-channel tubular high recovery efficiency cross counter flow type recuperator for preheating the combustion air from the flue gas leaving the furnace thereby the furnace would be very effectively designed in terms of fuel economy.

**4.7** Heating and soaking zones are to be controlled through stand-alone PID type temperature controllers with other necessary instruments or mass flow control philosophy. In order to maintain positive pressure in the furnace, necessary PID type furnace pressure control instruments will be used.

**4.8** Complete interlocking and sequential control of the furnace with respect to charge roller table, furnace charge pusher and discharge ejector and pull-out roll will be carried out through relay logic panel or Programmable Logic Controllers (PLC) complete with control processors, power supply module, I/O modules, digital input as well as offline programme. Redundant PLC system will be considered for critical functions like heating control etc. In case of failure of PLC some emergency sequence operation like pusher, discharge doors, ejector' can be operated through push buttons in manual mode.

**4.9** In case Coal is used as a fuel, furnace will be provided with impact type coal pulverizer capable of delivering (-) 200 mesh size of coal (about 80-90) along with hoppers (as required). PLC-PC based instrumentation for process control can also be used in place of standalone controllers.

## **5 CONSTRUCTIONAL DETAILS**

The furnace profile, effective lengths, width and sizing of the different zones will be decided so as to ensure optimum heating efficiency, uniformity of charge temperature and flexibility of furnace operation during varying capacity utilization.

Furnace profile will be such that the charge material stays for only the required (desired) time in the fired zones, but nevertheless undergoes very gradual heating in the long unfired preheating zone, through direct transfer of heat via the outgoing flue gases. This gives only advantages without increasing the scale levels.

### **5.1 Sizing of Furnace**

**5.1.1** Effective length and width of the furnace are to be calculated on the basis of output, reference charge material size, number of rows, material discharge temperature and uniformity, heating and soaking time. The following dimensions for the furnace are to be calculated:

The furnace effective length:

Inside furnace length	:	.....
Soaking zone length	:	.....
Heating zone length	:	.....
Preheating zone length	:	.....
Charge level of material with respect to mill floor level	:	To suit plant requirement
Discharge level of material with respect to mill floor level	:	To suit plant requirement.

**5.1.2** *Based on the typical heating configuration, the range of heating rates to be considered as :*

Top fired pusher type furnace : .....around 1min/mm  
Top and bottom fired pusher type furnace : ..... around 0.5min/mm

## **5.2 Furnace Casing**

The furnace casing will be fabricated from minimum 5 mm thick IS 2062 (Grade E 250 A) quality steel plates adequately reinforced with structural members. The casting used on front walls (door opening side) and the burner cut-out areas will be made of minimum 10 mm thick mild steel plates.

The suspended/arch roof is constructed by suitable beams framed to the structural members attached to the side buckstays. The intermediate beams are to be provided as required to stiffen the main beams and the support walkways. The main structural members will support the fired burner walls.

## **5.3 Walkways and Platforms**

All necessary platforms and access walkways on the furnace proper for servicing the burner, valve, drive mechanism, thermocouples and door drives.

The platforms and access walkways include all necessary structural supports, gratings, chequered plates and hand rails.

The platform will be designed for a minimum of 800 Kg/M.sq and walkways will be designed for a minimum of 500 Kgs/M.sq. loading.

## **5.4 Doors**

### **5.4.1 End Charge Door**

End charge door will have following details:

Type : Vertical rise and fall, counterweighted  
Quantity : 1 no  
Operation : Manual, winch-operated or electric motor/ hydraulic cylinder driven

Material : MS fabricated with graded cast iron cladding around periphery

Door insulation: Ceramic fiber / refractories of adequate thickness

The charge door will be manufactured from steel plates (IS 2062 Grade E 250 A) and structural with heat resistant cast iron at periphery. The door opening periphery will be fitted with heat resistant cast iron.

### **5.4.2 Door Drive Operation**

The door will be operated manually for which necessary shafting, bearings, sprockets, chains, winch etc. will be provided.

The door can also be operated hydraulically by means of hydraulic cylinder with necessary shafting, bearings, sprockets, chains etc. or electro-mechanically operated by suitable motor electric gear box with necessary electro-magnetic brake, chain and pulley etc. will be provided.

#### **5.4.2.1 Side discharge door**

Side discharge door will have following details:



Type	:	Vertical rise and fall
Quantity	:	2 nos. (one at each side of furnace)
Operation	:	Hydraulic cylinder/Electric motor/ pneumatic
Opening size	:	As required
Material	:	Heat resistant cast iron/Alloy steel

#### **5.4.3 Door Drive Operation**

The door can be operated hydraulically/pneumatically by means of hydraulic cylinder/pneumatic cylinder with necessary shafting, bearings, sprockets, chains etc. or electro-mechanically operated by suitable motor electric gear box with necessary electro-magnetic brake, chain and pulley etc. will be provided.

#### **5.4.4 Inspection Door**

Type	:	Manual, hinged type
Quantity	:	As required
Opening size	:	250 mm × 250 mm approx.
Materials	:	Graded cast iron and heat resistant cast iron
Operation	:	Manual

**5.4.4.1** Adequate number of inspection doors on both side walls will be provided. These doors will be manufactured from heat resistant cast iron for preheating zone and heat resistant cast iron for heating/soaking zones. The doors will be suitable for manual operation. The door opening periphery would be fitted with heat resistant cast iron.

#### **5.4.5 Access Doors**

Type	:	Manual, cover type, bolted
Quantity	:	As required
Opening size	:	Minimum 600 mm × 750 mm
Material	:	Mild steel plate (IS 2062 grade E250 A) of Min 5 mm thick
Operation	:	Manual

Adequate number of access doors made of minimum 5mm thick mild steel plate will be provided on the side of the furnace wall and will be bolted to the furnace casing suitably. The opening in the furnace side wall brick work for the access doors will be normally filled with refractory brick laid dry for easy removal of bricks at the time of maintenance/requirement of access inside the furnace.

#### **5.4.6 Clean Out Door**

Type	:	Manual, cover type, bolted
Quantity	:	As required
Opening size	:	Minimum 250 mm × 270 mm
Material	:	Heat resistant cast iron
Operation	:	Manual

Adequate number of clean-out doors made of heat resistant cast iron construction will be provided. The doors will be hinge type construction

## **5.5 Refractory and Insulation Material**

**5.5.1** Roof construction will be arch type if the width of the furnace is up to 2.2 M. Beyond this, the furnace roof is to be constructed with suspended roof hanger bricks. Refractory materials shall be selected to achieve skin temperature of furnace as under:

- a) All walls including hearth - 50 degree above ambient with 100°C (*Max*); and
- b) Roof - 120°C (*Max*).

Temperature will be measured 1 m away from the burner, door opening and any other opening on the furnace. Quality of refractory bricks shall be selected to withstand a minimum 100°C more than the maximum surface temperature at furnace face as well as at each layer face. Physical properties of refractory shall be selected as per customer choice. In the absence of the customer's choice, the same may be specified by the supplier.

### **5.5.2 Furnace Roof with Suspended Bricks**

- a) Soak zone and part of heating zone : 250 mm thick special shape roof brick made of minimum 60 percent alumina firebricks 115 mm hot face insulation bricks and 75 mm cold face insulation bricks.
- b) Balance zone : 250 mm thick special shape roof brick made of 45 to 55 percent alumina quality fire bricks 115 mm hot face insulation bricks 75 mm cold face insulation

The roof hangers shall be made of heat resistant cast steel, which will be held in position to the anchors of roof steel beams.

### **5.5.3 Furnace Roof with Arch Bricks**

- a) Soak zone and part of heating zone : 230 mm thick end arch fire bricks made of minimum 60 percent alumina bricks  
115 mm Hot face insulation bricks  
75 mm cold face insulation
- b) Balance zone : 230 mm thick end arch bricks made of 45 to 50 percent alumina fire bricks backed by 115 mm hot face insulating bricks  
75 mm cold face insulation

#### **5.5.4 Walls**

- a) Furnace Discharge End Wall, Furnace Soak and Part of Heating Zone Side Wall : 230 mm thick end bricks made of minimum 60 percent quality firebricks  
115 mm. hot face insulation bricks minimum  
115 mm. cold face insulation bricks minimum  
50 mm. block insulation or 50 mm ceramic fiber board (220 kg/m<sup>3</sup> density minimum, temperature range 1260 °C)
- b) Remaining zone side wall and Charge end wall : 230 mm thick end bricks made of minimum 40 percent alumina quality firebricks  
115 mm. hot face insulation bricks  
115 mm. cold face insulation bricks  
40 mm. block insulation and 50 mm ceramic fiber (64 kg/m<sup>3</sup> density, temperature range 1260 °C)

#### **5.5.5 Furnace Hearth**

- a) Soak Hearth : 200 mm thick High Alumina (70%) Low Cement Castable 115 mm thick High Heat Duty (IS-8) Firebricks.  
75 mm thick Hot Face Insulation Bricks.  
190 mm Insulating Castable/Insulation bricks followed by ceramic fiber board
- b) Heating Zone Hearth : 115mm Hot Face high temperature chromite/fused cast alumina bricks up to 4m from soak zone end and 70 percent Alumina Quality Firebricks at remaining heating zone.  
115mm high heat duty (IS 8) firebricks  
75mm Hot Face Insulation Bricks,  
150mm Cold Face Insulation Bricks
- c) Unfired Zone Hearth : 115mm high heat duty (IS 8) firebricks.  
115mm medium heat duty (IS 6) firebricks  
75 mm hot face insulation bricks  
115mm cold face insulation bricks

Castable on the soak hearth will be laid in position by heat resisting stainless steel anchors depending on temperature condition inside the furnace.

- 5.5.6** For Over-ground flue duct Before and After Recuperator : 150 mm thick of ceramic fiber blankets of different grades
- 5.5.7** For underground flue duct Before Recuperator : 230mm high heat duty firebricks (IS 8)  
75mm cold face insulation bricks  
150mm red bricks to be used as a ventilation course.
- 5.5.8** For underground flue duct after Recuperator : 230mm medium heat duty firebricks (IS 6)
- 5.5.9** Recuperator : Metallic to suit the flue gas temperature
- a) Stack : Bell portion of the chimney will be lined 230 mm. Medium heat duty quality firebricks backed by broken insulation bricks and portion up to a height of 5 M. from bell portion with 115 mm. medium heat duty quality firebricks and balance portion would remain unlined.  
In case the fuel is having sulphur content 3-4 percent, a fully lined chimney is preferred.
- b) Hot Air Lagging : 100mm thick mineral wool mattress covered with galvanized steel/aluminium sheet cladding
- c) Discharge Doors : 115mm 45 percent alumina firebricks  
115mm cold face insulation  
25 mm block insulation
- d) Charge door : 115mm 40 percent alumina firebricks  
75mm cold face insulation bricks
- e) Burner Blocks : 60 percent alumina refractory castable/ fired block or equivalent.

## **6 COMBUSTION EQUIPMENT**



Fig.3 GAS TRAIN CONTROL LOOP

### **6.2.2 UV Flame Monitoring Devices and Auto Burner Ignition**

UV photocell flame monitoring devices for each burner with pilot ignition equipment may be provided as required for safety.

Each burner will be provided with standard UV adaptor detector assembly which include UV detector and observation port. The UV photocell assembly is threaded into the back of the burner in place of its observation port.

In case of failure of burner flame, UV photocell will give impulse to solenoid valve to cut-off fuel supply to burner to avoid generation of unburnt fuel in the furnace resulting in fire hazards/explosion.

Auto burner ignition system for each burner will consist of an ignition transformer, spark plug.

UV flame monitoring system is recommended in case of gas firing system (for self-ignition temperature of the fuel is higher than 800°C).

### **6.3 For Oil Firing System**

For Oil firing system following system components are to be considered:

#### **6.3.1 Oil Pumping and Heating System**

For supply of oil at constant pressure and temperature, one oil recirculation system from termination point to the burners through ring main system are to be provided. To terminate the oil supply, an isolating valve is to be provided. Oil should be supplied from the day oil tank at slightly higher temperature (depending on the visco city) with free flow gravity pressure.

In order to preheat fuel oil at day tank, one no. outflow heater of adequate kW rating is to be provided at oil day tank.

For low viscosity fuel oils like LDO and HSD, heater may not be required.

Complete pumping and heating set shall comprise the following:

- a) 2 Oil pumps (1 working + 1 standby);
- b) 1 Suction side duplex filter;
- c) 1 Delivery side duplex filter;
- d) 1 Pressure regulating valve on return line with valves and by-pass valve; 1 Set Interconnecting pipeline; and
- e) 1 Lot of duplex oil heaters, each of adequate kW (1 working + 1 standby).

Zonal heaters are also to be provided for large furnaces where burners are located far from the oil heating unit to maintain desired temperature of oil. In case of furnace oil, an outflow heater of adequate kW rating is to be provided at the outlet of the oil day tank to preheat depending on viscosity of oil so that oil flows to the main heating and pumping unit smoothly.

Combustion air flow will be controlled zone-wise through:

- a) Wafer style butterfly valves with stainless steel internals for combustion air control (to be operated with modulating motor/pneumatic actuator with linkages);
- b) Butterfly valves in burner combustion air; and
- c) Butterfly valves in burner atomizing air (in case of oil firing).

The complete pumping and heating set will be fitted on a fabricated base frame with an oil drip tray. The pump will circulate approximately 2-3 times of oil requirement per hour in the oil ring main to maintain oil supply to burners at required flow and pressure.

Zone	No of burners (Approx)	Total Heat Release (Approx)	Firing Arrangement
Soak zone	..... (Required)	..... million kcal/ hr or kW	Across width/ length
Heating Zone - I	..... (Required)	..... million kcal/ hr or kW	Across width/ length
Heating Zone - II	..... (Required)	..... million kcal/ hr or kW	Across width/ length

**6.3.2 Other Equipment Fittings used Oil Firing System are as under**

- a) Sensitrol oil valves in oil line;
- b) Oil flexible hoses;
- c) Oil shut-off valve;
- d) Adjustable port valve for zone control; and
- e) Oil solenoid valve for zone (oil solenoid valve for each burner, when UV flame monitoring system is used).

**6.4 For Coal Firing System**

**6.4.1 Pulveriser** — The size and capacity will be selected based on type of coal and coal consumption rate. The body will be made either cast iron or M.S. Sheet. The pulverizer shall be capable of delivering (-) 200 mesh coal powder size of about 75-85%.

The upper portion of the hopper bin shall be covered with M.S. sheet to contain coal dust spreading out during collection in the hopper.

The following general recommendation will be as following:

Hammer	:	High Manganese
Liner	:	E4 – 31 steel
Classifier blade	:	Stainless steel
Fan Blades	:	Stainless steel

**7 BLOWERS**

### **7.1 Combustion Air Blower**

Adequate number of combustion air blowers with standby of suitable capacity and pressure are to be provided. The blower will be arranged for direct/V-belt/ coupling driven through a suitable motor. Following details shall be indicated on the blower:

- a) Capacity ( $\text{m}^3/\text{h}$ );
- b) Pressure, mm WG;
- c) Motor rating (kW);
- d) Type of drive; and
- e) Simply supported/cantilever type

Blowers shall be centrifugal type, mild steel construction and statically and dynamically balanced. Blower capacity cannot be less than the air requirement considering the connected load of the furnace.

NOTE — VFD/VVFD for combustion air blower may be considered as optional.

### **7.2 Atomizing Air Blower (for Oil Firing)**

Adequate number of atomizing air blowers with standby of suitable capacity and pressure are to be provided. The blower will be arranged for direct/V-belt/coupling driven through a suitable motor. Following details shall be indicated on the blower:

- a) Capacity ( $\text{m}^3/\text{h}$ );
- b) Pressure, mm WG;
- c) Motor rating (kW); and
- d) Type of drive.

Blowers shall be centrifugal type, mild steel construction and statically and dynamically balanced. Blower capacity cannot be less than the air requirement considering the connected load of the furnace.

NOTE — VVFD for atomizing air blower may be considered as optional.

### **7.3 Pulverized Coal Transportation Blower**

Suitable capacity and pressure blower will be provided. The blower will be arranged for direct/V-belt/coupling driven through a suitable motor. Following details shall be indicated on the blower:

- a) Capacity ( $\text{Nm}^3/\text{h}$ );
- b) Pressure, mm WG;
- c) Motor rating (kW);
- d) RPM;
- e) Type of drive; and
- f) Simply supported/cantilever type.



Blowers shall be centrifugal type, mild steel construction and statically and dynamically balanced. Blower capacity shall be suitable for transporting pulverized coal to the burners at suitable pressure considering pressure drop in the system

NOTE — VVFD/VFD for combustion air blower may be considered as optional.

## **8 PIPE WORK**

### **8.1 Combustion Air Pipeline**

Cold air piping from the combustion air fan to the recuperator and hot air piping between the recuperator and burners through individual zone headers would be provided. The pipeline will be flanged at appropriate intervals and supported by brackets. Combustion air blower will be located near the recuperator. Flexible bellows should be provided in preheated combustion air line to take care of expansion and alignment during pipe assembly. Hot air piping shall be internally lined or of suitable grade to withstand the hot air temperature with external insulation.

### **8.2 Atomizing Air Pipeline (In Case of Oil Firing)**

Necessary atomizing air pipeline up to burners will be provided. The pipelines will be supported at appropriate places.

### **8.3 Dilution Air Piping**

Dilution air piping from dilution air fan to the flue tunnel where the recuperator is placed.

### **8.4 Gas Piping**

Gas piping from termination point to various zones including distribution network complete with valves and fittings will be included. An isolating valve is to be provided. Gas pressure at takeover point should be min 0.07-0.08 kg/cm<sup>2</sup>.g

### **8.5 Oil Piping**

Oil piping from the oil pumping and preheating unit to the burners through the ring-main system will be included. Fuel oil supply to the oil pumping and heating unit at a free flow gravity pressure of 0.5-1.5 kg/cm<sup>2</sup>.g and pumpable temperature (about 50-60°C temperature for furnace oil) at header at the battery limit with an isolating valve is to be provided. All pipelines from this point to the points of usage through the ring-main will be provided.

### **8.6 Hydraulic Piping (if Applicable)**

The hydraulic pipe work for the pusher and ejector mechanism as well as charge and discharge doors including all necessary valves, flexible pipes, fittings and supports are to be provided. All fittings and sockets will be of weldable quality. All the pipes will be from seamless tubes suitable to withstand hydraulic pressure.

## **9 RECUPERATOR**

One multi-channel tubular cross counter flow type. Recuperator will be required for preheating the combustion air to a temperature of upto 650°C. As a general guideline the design of the recuperator should be such that it recovers 75 to 80% of the heat contained in the flue gas.

The recuperator includes two or more completely assembled suspended units in which the front (hot) bank of tubes are made of suitable special alloy steel and the balance tubes are made of carbon steel.

**9.1 Operating Data (Approximately):**

- a) Fuel : .....
- b) Connected heat load for furnace with recuperator : ..... kW
- c) Waste gas flow : ..... Nm<sup>3</sup> /h
- d) Temperature of waste gas:
  - 1) At entry to recuperator : ..... °C (Max.)
  - 2) At exit to recuperator : ..... °C (indicative)
- a) Combustion air flow : ..... Nm<sup>3</sup>/h
- b) Temperature of air:
  - 1) At entry to recuperator : ..... °C (ambient)
  - 2) At exit to recuperator (desired) : ..... °C (350°C or above)
- a) Pressure drop across :
  - 1) Air side : 150 - 350 mm WG approx.
  - 2) Flue side : 10 - 20 mm WG approx

**9.2 Dilution Air Blower**

Adequate number of dilution air blowers with standby of suitable capacity (10-15% of combustion air flow) and pressure are to be provided. The blower will be arranged for direct/V-belt/coupling driven through a suitable motor. Following details shall be indicated on the blower:

- a) Capacity (m<sup>3</sup>/h);
- b) Pressure, mm WG;
- c) Motor rating (kW); and
- d) Type of drive.

Blowers shall be centrifugal type, mild steel construction and statically and dynamically balanced. Blower should have sufficient reserve capacity over and above the design requirement.

NOTE — VVFD for dilution air blower may be considered as optional.

**9.3 Hot Air Bleed**

A hot air bleed system will be provided to give further protection to the recuperator. Should the hot air temperature exceed the safe temperature limit, the hot air bleed control opens the bleed valve which allows a greater quantity of combustion air to flow through the recuperator tubes. The hot air that is

exhausted is usually piped back into the waste gas flue between the recuperator and the stack.

#### **9.4 Flues**

- a) Type : Underground or overhead
- b) Insulation : Inside

The furnace will be provided with underground/ overground flue duct for exhausting of waste gas from furnace to the chimney through recuperators. Overhead flue duct will be made of steel plates with flanges and supporting structures. The flue duct will be lined inside with suitable insulation material.

Underground flue duct will be made of RCC which will be lined inside with suitable refractory and insulation material.

#### **9.4 Dampers**

- a) Application : To regulate outgoing flue gases, and hence, Furnace chamber pressure
- b) Location : In the overhead/ underground flue duct after recuperator
- c) Type : Rise and fall type for underground and rotary type for overhead

One guillotine rise and fall type (or, rotary type) damper would be provided in the underground flue, after the combustion air recuperator. The damper would be made of AISI-304 stainless steel plates suitably stiffened. The damper will be suitable for actuation with an electro- mechanical/pneumatic actuator and will be provided with a damper operating mechanism.

#### **9.5 Stack (See IS 6533)**

- a) Type : Self-supported, natural draught
- b) Height : .....m
- c) Material of construction : Mild steel (IS 2062 Grade E 250. A)
- d) Insulation : Inside

The stack is a self-supporting partially/fully refractory lined natural draft chimney of suitable height. The stack is of welded construction. The chimney will be of suitable height and diameter considering Central Pollution Control norms and will be designed and constructed as per relevant IS standard along with lightning arrestor, earthing, platform, ladder, aviation lamp, sample ports etc. The lining configuration of the chimney will be as described under refractory and insulation material.

Induced draft chimney can also be provided, if desired due to limitation of height in the plant area and / or any other design requirement.

### **10 CHARGE PUSHER MECHANISM**

- a) Application : To feed charge into the furnace
- b) Type : Hydraulic/electro-mechanical
- c) Operation : Hydraulic/motorized

- d) Speed : .....m/min
- e) Pushing force : .....kg
- f) Stroke : .....mm

The material will be pre-positioned in front of the charge end of the furnace through the charge roller table (or, placed directly on the charge table in front of the furnace).

For pushing the material inside the furnace, hydraulically/electro-mechanically operated charge pusher mechanism will be provided. The hydraulically/ electro-mechanically operated pusher mechanism will push the material up to a required distance and adequate speed.

Pusher will be designed considering the total pushing load in hearth, cycle time required for output, speed and stroke length.

The pusher head will be constructed from a heavy mild steel structural section with necessary stiffening arrangement. Hydraulic cylinders along with necessary valves for proper operation will be required.

Hydraulically/electro-mechanically operated pusher mechanism will push the material in one/two/triple row as desired.

## **11 DISCHARGE EJECTOR**

- a) Application : To discharge the material from the furnace
- b) Type : Electro-mechanical or electro-hydraulic
- c) Operation : Motorized (or,through hydraulic arrangement
- d) Speed : ..... m/min
- e) Pushing force : ..... kg
- f) Stroke : .....mm

For charging of the hot billets from the furnace to the discharge roller table, one (1) no. electro-mechanically (or, electro-hydraulic) operated discharge ejector shall be provided. The main drive roll will be connected with suitable capacity motor and gearbox assembly. Necessary guide rolls and support rolls will be provided throughout the ejector rod for uniform loading. Necessary water piping will be provided above the ejector rod for uniform spray of water. The ejector machine shall have facility for cross movement. The cross movement shall be effected by means of a hydraulic cylinder, which will be operated from hydraulic power pack. The ejector rod will have adequate stroke to push the billets onto the furnace discharge table. However, to reduce the stroke of ejector a furnace pull-out roll may be provided.

## **12 PULL-OUT ROLL ASSEMBLY**

- a) Application : To discharge the material from the furnace
- b) Type : Hydraulic/electric
- c) Operation : Hydraulic/electric
- d) Speed : .....m/min

e) Weight of charge material : .....kg

One set furnace pull-out roll assembly, which will work in conjunction with the discharge ejector mechanism are to be provided.

Pull-out role will help in pulling-out the material from the furnace faster and ultimately place it on the discharge roller conveyor. This will help the ejector machine to be designed for a smaller pushing stroke.

The pull-out roll will consist of two driven rolls (one stationary bottom roll and the other hydraulically clamping top roll). Both the rollers will be driven by a pinion stand, which will be driven by an electro-mechanical drive unit consisting of motor, gearbox, couplings and shaft etc.

Both the rollers shall be of solid steel rolls of suitable diameter supported on anti-friction bearings and housed in water-cooled bearing blocks.

### **13 HYDRAULIC POWER PACK**

- a) Application : Operation of pusher, ejector, pull-out roll assembly
- b) Number of hydraulic : 2 Nos. (1 working + 1 standby) pumps
- c) Pump capacity : ..... l/min each
- d) Design Pressure : 160 kg/cm square approximately
- e) Normal working : 100 – 120 kg/cm<sup>2</sup> approximately pressure
- f) Connected motor : .....hp, energy-efficient\
- g) Accessories :

- 1) Hydraulic pumps with couplings and motors
- 2) Solenoid operated direction control valves
- 3) Solenoid operated unloader valve
- 4) Pressure relief valve
- 5) Flow control valves
- 6) Oil reservoir with air breather and strainer
- 7) Pressure gauges
- 8) Heat exchanger for oil cooling
- 9) Level indicator
- 10) Low level switch
- 11) Non-return valves
- 12) Interconnecting piping
- 13) Manifolds and other fittings

For operation of hydraulic cylinders of charge pusher, hydraulic cylinder for discharge doors, hydraulic torque motor and cross travel cylinder for ejector, one common composite hydraulic power pack unit comprising of hydraulic oil storage tank, 2 Nos. (1 working + 1 standby) pumps with suitable HP motor, necessary valve station etc. are to be provided. The system would be suitable for operating pressure of 120 Bar and system pressure would be 160 Bar. The hydraulic system would also include one water cooled heat exchanger which will cool the hydraulic oil during operation.

### **14 INSTRUMENTATION AND CONTROL**

### **14.1 PID Type Control Through Stand Alone Controllers**

- a) The furnace zone temperature will be automatically controlled through microprocessor- based PID temperature controllers on mass flow-based control principle. Manual override facility shall be provided;
- b) In order to maintain positive pressure in the furnace, necessary furnace pressure control instruments will be used. Automatic furnace pressure control will maintain positive pressure inside the furnace to reduce ingress of outside air to minimum, which will ultimately reduce oxidation of charge material and thereby scale loss. Manual override facility shall be provided; and
- c) The furnace sequence will be controlled by a Relay Logic Panel or PLC-PC based system.

**14.2** The furnace will be divided into required control zone and zone temperature shall be controlled by the stand- alone PID controllers. The instrumentation system shall be suitable for operating on a power supply of 220 V, single phase, 50 Hz, AC supply obtained from MCC Panel.

The instrumentation system of the furnace will consist of the following controls and interlocking:

- a) Zone temperature control;
- b) Furnace pressure control;
- c) Preheated air temperature control (recuperator protection);
- d) Hot air bleed control;
- e) Flue gas temperature control through dilution air (recuperator protection); and
- f) Safety interlocking as required for the furnace system.

#### **14.2.1 Zone Temperature Control**

- a) Pt. Pt/Rh 13 percent simplex thermocouple with necessary compensating cable;
- b) PID temperature controllers;
- c) Gas/oil/coal/air ratio controllers;
- d) Air/gas(oil/coal) orifice plates;
- e) Air/Gas(oil/coal) flow transmitters;
- f) Oil/Gas/coal flow meters;
- g) Air control valve with electro-mechanical/ pneumatic actuator
- h) Gas/Oil control valves with electro-mechanical/ pneumatic actuator;
- i) Coal feed control through weigh feeders; and
- j) ON/OFF override temperature controllers.

Quantity of above instruments will be decided on the basis of heating and soaking control zones.

#### **14.2.2 Furnace Pressure Control**

- a) 1 No. — Furnace pressure transmitter;
- b) 1 No. — PID type microprocessor-based pressure indicating controller; and

- c) 1 No. — Modulating motor /pneumatic actuator for damper actuation in flue line.

#### **14.2.3 Preheated Air Control Loop (Hot Air Bleed Control)**

- a) One (1) — Ni.Cr./Ni.Al. simplex thermocouple with compensating cable;
- b) One (1) — ON/OFF temperature controller; and
- c) One (1) — Wafer style control valve with electromechanical/pneumatic actuator.

#### **14.2.4 Flue Gas Temperature through Dilution Air Control**

- a) One (1) — Ni.Cr./Ni.Al. simplex thermocouple with compensating cable;
- b) One (1) — ON/OFF temperature controller; and
- c) One (1) — Wafer style control valve with electrical/pneumatic actuator.

### **14.3 Instrument Panel**

One 2 mm thick sheet steel construction, single cubicle type with fixed front and rear two leaf hinge door suitably sized instrument panel to house the required front panel microprocessor-based controllers, lamps, switches and other back of panel devices like relays, fuses, MCBs, terminal blocks etc. will be provided.

### **14.4 Annunciator**

The instrument panel will be provided with one no. standalone solid-state multi-channel audio/visual solid-state annunciator having front facia with legends of fault points and shall have the following features:

Fault conditions will activate audible alarm and flash the associated facia of the annunciator.

- a) On pressing the “acknowledge push button” the audible alarm will be silent and fault facia nameplate will become steady;
- b) When fault is cleared, the facia will go “off” when reset push button is pressed; and
- c) All alarm units will be independent of each other and will have legends engraved on the front facia.

Alarm conditions will include the following fault points for safety:

- a) High gas pressure : 1 point
- b) Low gas pressure : 1 point
- c) Low oil Pressure : 1 point
- d) Low combustion : 1-point air pressure
- e) Low atomizing pressure : 1 point
- f) High zone temperature : as required
- g) High combustion air temperature after recuperator : 1 point
- h) High waste gas entry temperature to recuperator : 1 point
- i) High furnace pressure : 1 Point

j) Spares : as required

#### **14.5 PLC-PC Based Mass Flow Control**

It is advisable to provide PLC-PC based instrumentation system in the furnace for the following:

- a) Indication, recording and control of furnace temperature in each zone;
- b) Indication and control of fuel oil/gas in each zone;
- c) Indication, recording, control and totalization of fuel oil/gas flow in main header / coal weigh feeder and feed rate measurement through load cell-based conveyer weighing;
- d) Indication and control of combustion air flow;
- e) Indication, recording and control of furnace pressure;
- f) Indication of flue temperature and control of dilution air to recuperator;
- g) Indication of preheated air temperature control;
- h) Indication and recording of combustion air temperature at recuperator inlet and outlet;
- i) Indication of fuel oil/gas pressure at main header;
- j) Data for process control, and
- k) Any other data required.ZZ

The PLC-PC based instrumentation system shall be flexible and user friendly with user friendly interface in HMI (Human Machine Interface) (*see Fig. 4*).

The PLC-PC based instrumentation system will consist of the following.

##### **14.5.1 Temperature and Air/Fuel Ratio Control (Mass Flow Based) — (*see Fig. 5 and Fig. 6*)**

- a) ‘R’ type with suitable length below flange simplex thermocouple for zone temperature control / excess zone temperature control;
- b) Modulating motor /pneumatic actuator for air flow control valves;
- c) Airline orifice plates;
- d) Air flow transmitter;
- e) Oil flow meters;
- f) Oil flow control valves;
- g) Modulating motor/pneumatic actuator for oil control valves;
- h) Gas line orifice plates;
- i) Gas flow transmitters;
- j) Gas control valves;
- k) Modulating motor/pneumatic actuator for gas control valves;
- l) Coal weigh feeder and feed rate measurement through load cell-based conveyer weighing; and
- m) ON/OFF excess zone temperature controllers.

##### **14.5.2 Preheated Air Control Loop (Hot Air Bleed Control) (*see Fig. 7*)**



- a) One (1) — Ni.Cr./Ni.Al. simplex thermocouple with compensating cable
- b) One (1) — Wafer style control valve with electromechanical/pneumatic actuator

### **14.5.3 Flue Gas Temperature through Dilution Air Control**

- a) One (1) — Ni.Cr./Ni.Al simplex thermocouple with compensating cable
- b) One (1) — Wafer style control valve with electrical /pneumatic actuator

The PID controllers for furnace zone temperature shall be constituted within the PLC through intelligent software PID blocks. The value and status of zone temperature can be viewed on the Human Machine Interface (HMI) screen of the colour monitor for the furnace work station.

For excess temperature control of respective zones, provision for stand-alone ON/OFF override temperature controllers have been considered. In case the zonal temperature overshoots the maximum set value it will shut off the zone fuel oil/gas valve and at the same time the system will raise an audio-visual alarm. Details of alarm and fault will be logged in HMI.

### **14.6 Furnace Pressure Control** (*see Fig. 8*)

The furnace will be provided with one set of furnace pressure controlling instrument consisting of the following:

- a) 1 No. draft range furnace pressure transmitter; and
- b) 1 Set damper and actuating motor.

Furnace pressure control is important to maintain slightly positive pressure inside the furnace to prevent ingress of atmosphere air into the furnace which will help in reducing oxidation thereby reducing scale formation.

Furnace pressure control will be through a common PLC in which necessary components will be provided in the PLC.

### **14.7 PLC and its Panel**

The PLC, its accessories and relays shall be housed inside a non-compartmentalized 2 mm thick sheet steel construction, self-standing dust and vermin proof type panel. Wirings shall be completed up to the terminals. All incoming and outgoing cable shall be through a 3 mm thick gland plate provided at the bottom of the panel.

The panel doors shall be two leaf hinged type at both front and rear of the panel. The panel shall be painted inside and outside light grey (Shade no.631 of IS 5).

One non-redundant type Programmable Logic Controller (PLC) for the furnace will be provided for interlocking and sequential control and for furnace process control like temperature etc. The PLC would be complete with one control processor, one power supply module, and required digital input/output cards, analog card, T/C card etc. Redundant PLC system may be considered for critical functions like heating control etc. The unit would be located in an air-conditioned electrical control room in a dust and vermin proof enclosure.

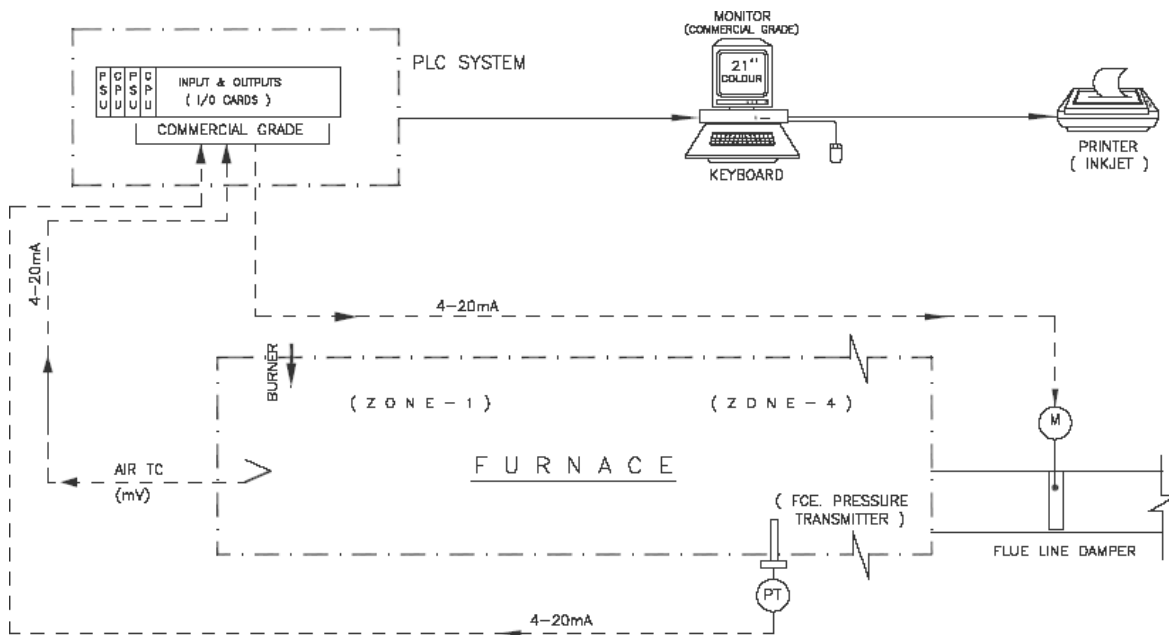

**Fig. 4 SYSTEM CONFIGURATION**

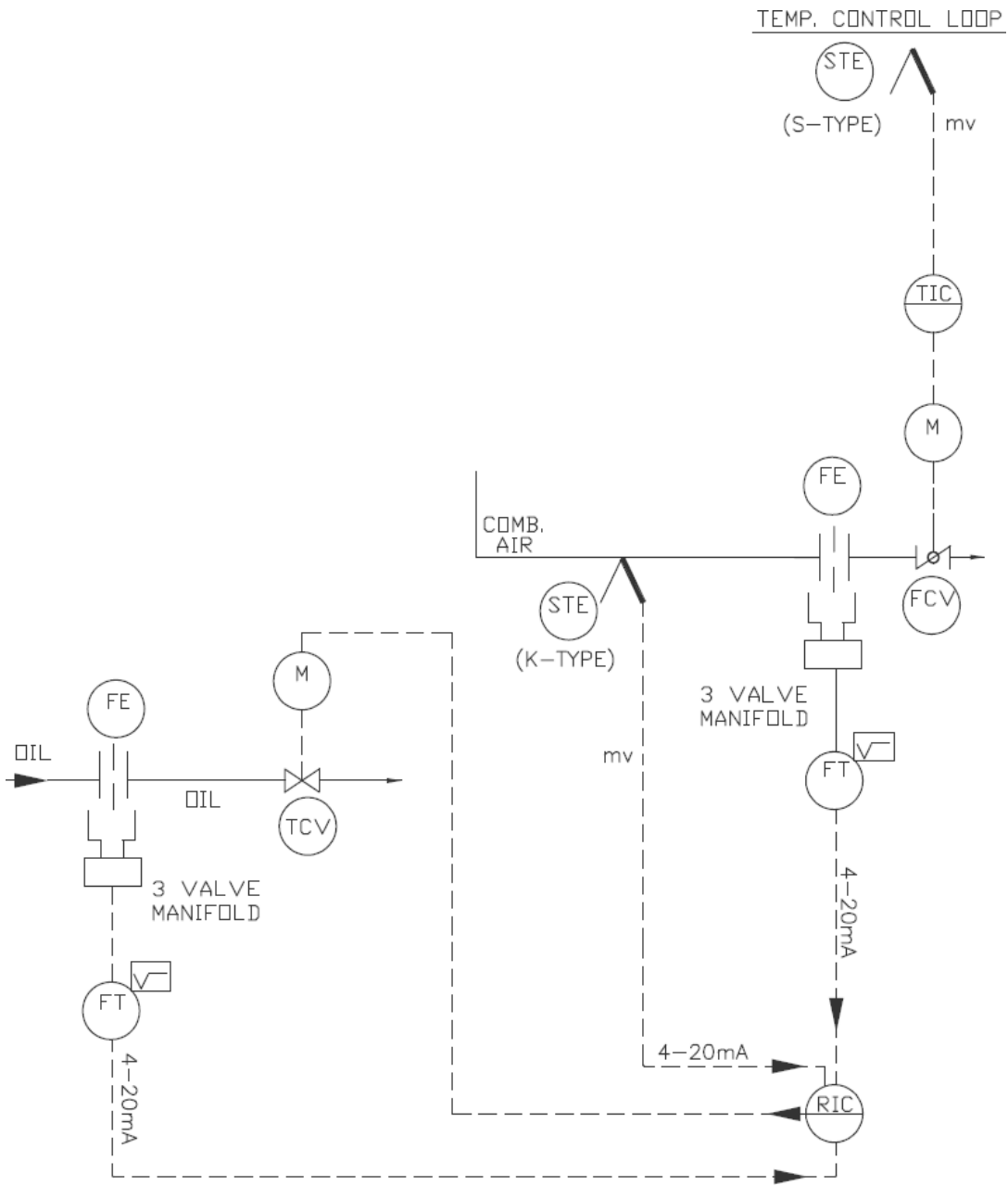

**Fig. 5 TEMPERATURE CONTROL LOOP FOR OIL LINE**

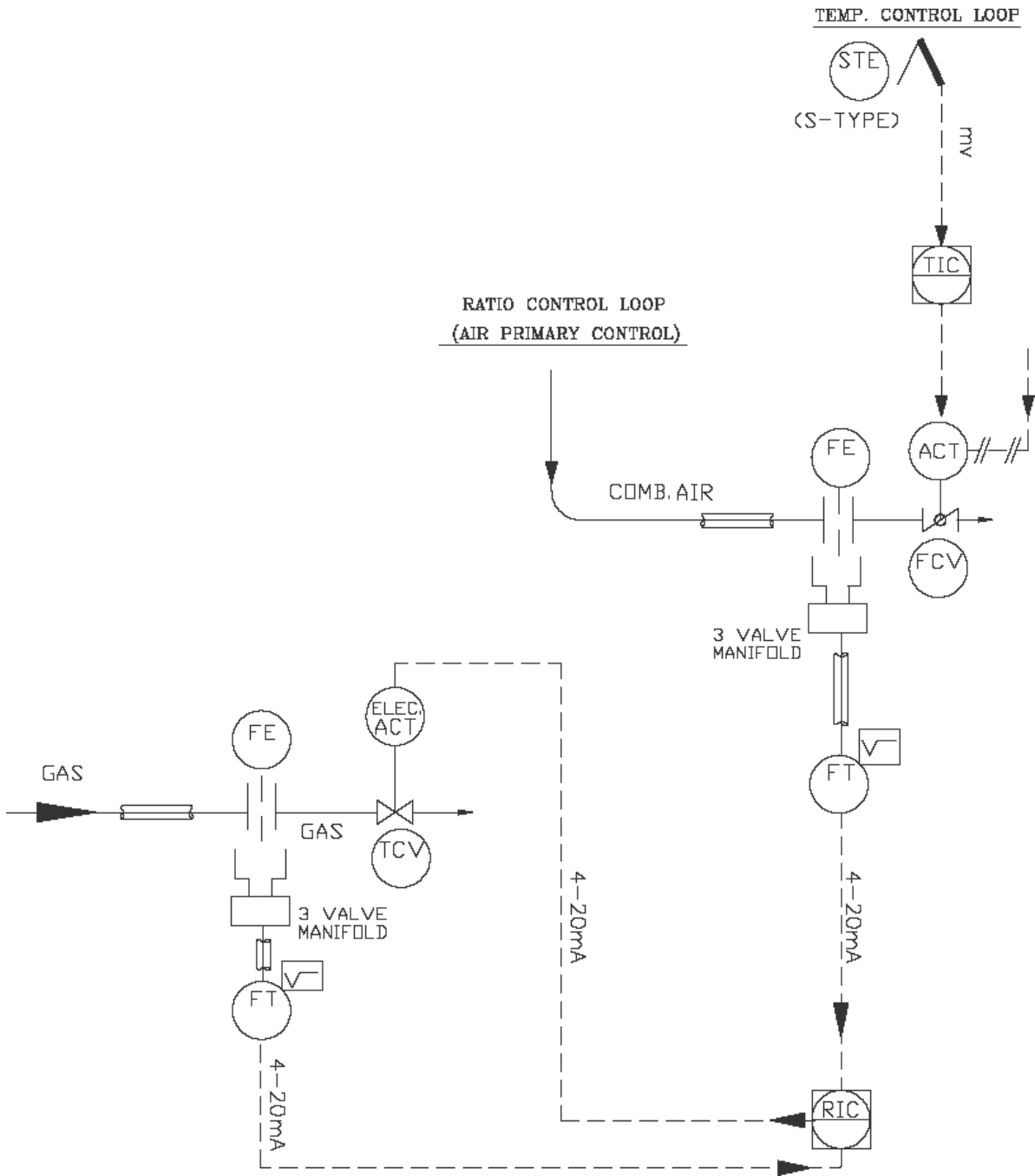

**Fig. 6 TEMPERATURE CONTROL LOOP FOR GAS LINE**

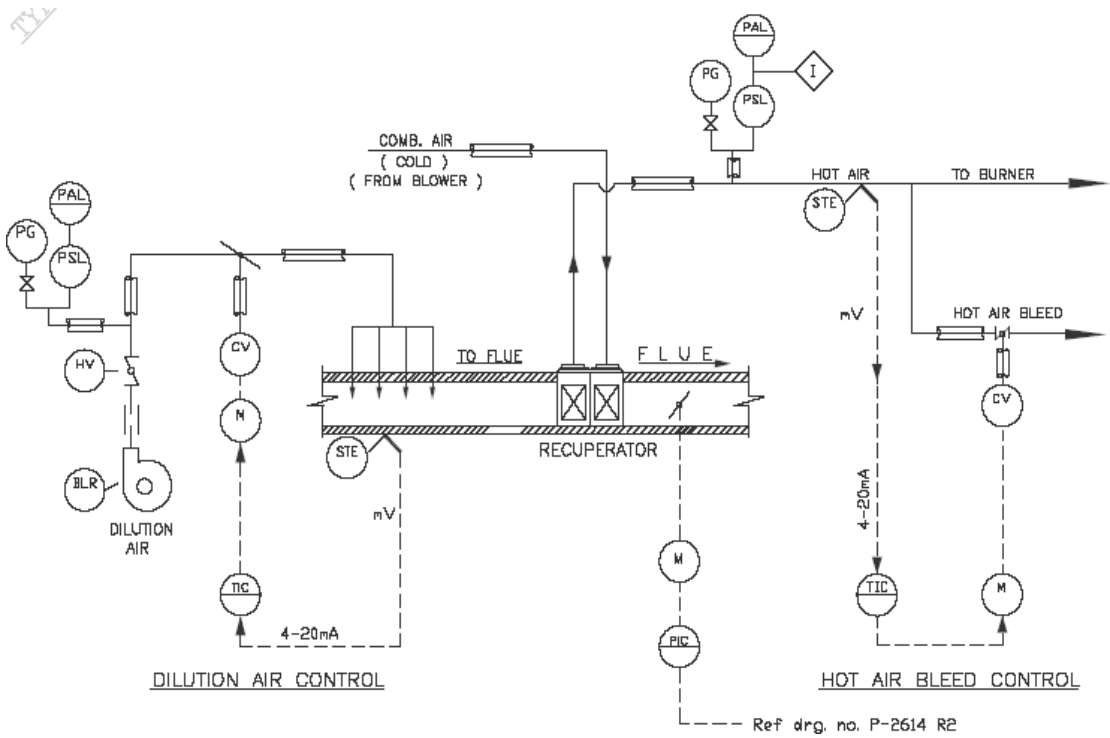

Fig. 7 P AND I DIAGRAM – TEMPERATURE CONTROL OF PREHEAT COMBUSTION AIR

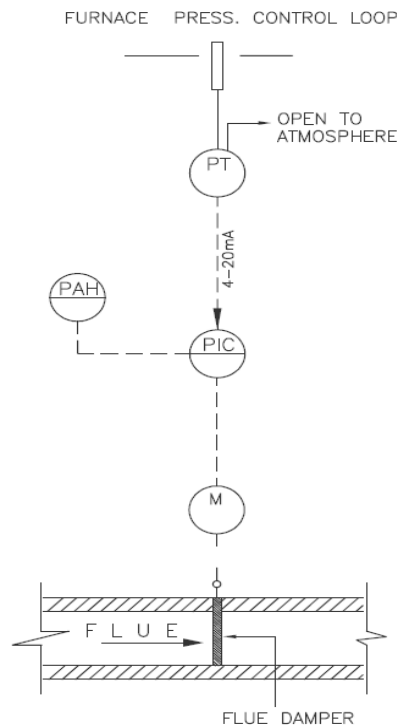

Fig. 8 FURNACE PRESSURE CONTROL LOOP

<b>Symbol</b>	<b>Description</b>
M	Motor operated
PT	Pressure Transmitter
PIC	Pressure Indicating Controller
PG	Pressure Gauge
PSL	Pressure Switch Low
PAH	Pressure Alarm High
PAL	Pressure Alarm Low
TIC	Temperature Indicating Controller
TCV	Temperature Control Valve
CV	Control Valve
FCV	Flow Control Valve
FE	Flow Element
FT	Flow Transmitter
RIC	Radioactivity indicator controller
ACT	Actuator
BLR	Blower
HV	Butterfly Valve (hand operated)
STE	Simplex Temperature Element

**14.7.1** In addition to process and sequence control through PLC, following features will be available through PC based system on monitor screen in various pages,

- a) Temperature and pressure data logging and trending;
- b) Overview of furnace; and
- c) Fault annunciation page and alarm logging.

**14.7.2** Alarm conditions will include the following fault points for safety:

- a) High gas pressure : 1 point
- b) Low gas pressure : 1 point
- c) Low oil pressure : 1 point
- d) Low combustion air pressure : 1 point
- e) Low atomizing pressure : 1 point
- f) High zone temperature : As required
- g) High combustion air temperature after recuperator : 1 point
- h) High waste gas entry temperature to recuperator : 1 point
- i) High furnace pressure : 1 Point
- j) Spares : As required

**14.7.3** Besides this, the PLC-PC based instrumentation shall log the data as detailed below:

- a) Shift-wise, daily, monthly, yearly report with process values/production figures and other process data. However, same shall be finalized during detailed engineering process;
- b) Logging and reports of events; and
- c) Historical data storage and trending.

The PC shall have limited storage capacity. As and when the hard disk capacity space reduces substantially due to storage of data, the same is to be stored in DVDs/CDs for future and hard disk space is to be restored.

### **14.8 Workstations - PC and Printer**

One set common grade PC consisting of latest processor with colour monitor, CD Rom, compatible keyboard, mouse, one (1) No. colour laserjet/inkjet printer. UPS should be provided as power supply utility.

#### **14.8.1 Programmable Logic Controller (PLC) for Sequential Operation**

A common Programmable Logic Control Panel (PLC) indicated above will also be suitable for interlocking and sequential control of operation of charge rollers, charge pusher, discharge doors, discharge ejector, pull- out roll and charge doors.

The common panel shall also control the entire sequential operation of the furnace and its allied equipment which are provided along with process control as described above.

## **15 SAFETY INTERLOCKING IN THE FURNACE**

The safety against various abnormal conditions like excess zonal temperature, excess furnace pressure, low oil pressure, high/low gas pressure, low combustion air pressure, shall be interlocked in such a way so that in the event of occurrence of such faults, respective safety devices (control/alarm) will be activated to prevent any adverse situation in the furnace.

The furnace will be provided with following safety interlocks for safe operation;

- a) Air temperature control instruments with broken thermocouple safety protection (upscale);
- b) To cut-off zone burner firing with the help of oil safety solenoid valves and On/OFF gas control valves in the event of excess temperature; and
- c) Necessary limit switches as required will be provided to ensure safe operation of the furnace.

## **16 ELECTRICAL**

### **16.1 Motor Control Centre**

The furnace will be provided with one dust and vermin proof, 2mm thick sheet steel, floor mounted type totally enclosed non-compartmentalized/compartimentalized and non-draw out type motor control centre for the operation of various motors and heaters. Cable entry shall be from bottom of panel through 3 mm

thick gland plate at bottom of panel. MCC panel, Junction Boxes etc., shall be: painted – Inside and Outside: Light Grey, Shade No.631 of IS 5.

In addition to the above, two control desks, adequate number of control stations and local push button stations are required to be located at charging and discharging end for operation.

## **16.2 Power and Control Cables**

All power and control cables including cable laying accessories from MCC panel and Instrument panel to various motors/heaters and field instruments are to be decided on the basis of cable routing layout and kW ratings.