

भारतीय मानक मसौदा

ब्लड गैस एनालाइज़र - इन-विट्रो डायग्नोस्टिक्स (आईवीडी) उपकरणों का प्रदर्शन
परीक्षण

Draft Indian Standard

Blood Gas Analyzers - Performance testing of in-vitro Diagnostics (IVD)
Instruments

ICS [11.040.55; 11.100.30]

© BIS 2020
BUREAU OF INDIAN STANDARDS
MANAK BHAVAN, 9 BAHADUR SHAH ZAFAR MARG
NEW DELHI 110002

December 2020

Price Group

Biological Evaluation of In-vitro Diagnostic Medical Devices Sectional Committee, MHD 19

FOREWORD

This Draft Indian Standard is to be adopted by the Bureau of Indian Standards after the draft finalized by the Biological Evaluation of In-vitro Diagnostic Medical Devices Sectional Committee and approval by the Medical Equipment and Hospital Planning Division Council.

This Standard describes the specifications for Blood Gas Analyzers which are used for the quantitative determination of various levels of pH, pCO₂, pO₂, Hct, Na⁺, K⁺, Cl⁻, iCa, Li, Glu (Glucose) and more, in heparinized whole blood and standard testing procedure for testing of performance.

Whole blood measurement of certain gases as pCO₂, PO₂, in whole blood, or pH of whole blood, are used in the diagnosis and treatment of life-threatening acid-base disturbances.

Whole blood measurements of the packed red cell volume (Hct) of a blood sample are used to distinguish normal from abnormal states, such as anemia and erythrocytosis (an increase in the number of red cells).

Sodium (Na⁺) measurement is used in the diagnosis and treatment of aldosteronism, diabetes insipidus, adrenal hypertension, Addison's disease, dehydration, or diseases involving electrolyte imbalance.

Potassium (K⁺) measurement is used to monitor electrolyte balance in the diagnosis and treatment of disease conditions characterized by low or high potassium levels.

Chloride (Cl⁻) measurement is used in the diagnosis and treatment of electrolyte and metabolic disorders such as cystic fibrosis and diabetic acidosis.

Calcium (iCa) measurement is used in the diagnosis and treatment of parathyroid disease, a variety of bone diseases, chronic renal disease and tetany (intermittent muscular contractions or spasms).

Lithium (Li) measurement are used in the diagnosis and treatment for muscular weakness, Kidney and for mental disorder.

Glucose (Glu) measurement is used in the diagnosis and treatment of carbohydrate metabolism disturbances including diabetes mellitus, neonatal hypoglycemia, and idiopathic hypoglycemia, and of pancreatic islet cell carcinoma.

Lactate (Lac) measurement is used in the diagnosis to determine the status of the acid-base homeostasis in the body.

Arterial Blood Gases (ABG) are measured through a clinical test that involves measurement of the pH of arterial blood and the amount of oxygen and carbon dioxide dissolved in arterial blood, routinely used in the diagnosis and monitoring of predominantly critically/ acutely ill patients being cared for in hospital emergency rooms and intensive care units. The test allows the assessment of two related physiological functions: pulmonary gas exchange and acid-base homeostasis.

The measurements are to be conducted by a trained professional in a clinical laboratory for in-vitro diagnostic use only.

The Technical Committee responsible for the preparation of this standard has reviewed the provisions of the following International Standards/Other Publications and has decided that they are acceptable for use in conjunction with this standard:

<i>International Standard</i>	<i>Title</i>
ASTM D4169-16	: Standard Practice for Performance Testing of Shipping Containers and Systems
C 46-A2	: Blood Gas and pH Analysis and Related Measurements, 2 nd Edition
CLSI EP05-A3	: Evaluation of Precision of Quantitative Measurement Procedures, 3 rd Edition
CLSI EP06-A	: Evaluation of the Linearity of Quantitative Measurement Procedures: A Statistical Approach, 1 st Edition
CLSI EP09-A3	: Measurement Procedure Comparison and Bias Estimation Using Patient Samples, 3 rd Edition
EP 07-A2	: Interference Testing in Clinical Chemistry, 3 rd Edition
EP 17-A2	: Evaluation of Detection Capability for Clinical Laboratory Measurement Procedures, 2 nd Edition
EP 25-A	: Evaluation of Stability of In Vitro Diagnostic Reagents, 1 st Edition
GP 41	: Collection of Diagnostic Venous Blood Specimens, 7 th Edition

DRAFT IN WIDE CIRCULATION FOR COMMENTS ONLY
(Not to be reproduced without permission or used as standard)
Doc. No. MHD 19 (15611)

- GP 43-A4 : Procedures for the Collection of Arterial Blood Specimens;
Approved Standard-4th Edition
- IEC 61326-1: 2020 : Electrical equipment for measurement, control and laboratory use -
EMC requirements - Part 1: General requirements
- IEC 61326-2-6: 2020 : Electrical equipment for measurement, control and laboratory use -
EMC requirements - Part 2-6: Particular requirements - In vitro
diagnostic (IVD) medical equipment
- ISO/IEC Guide 99: 2007 : International vocabulary of metrology -- Basic and general
concepts and associated terms (VIM)

For the purpose of deciding whether a particular requirement of this standard is complied with, the final value, observed or calculated, expressing the result of a test or analysis, shall be rounded off in accordance with IS 2: 1960 'Rules for rounding off numerical values (*revised*)'. The number of significant places retained in the rounded off value shall be the same as that of the specified value in this standard.

1. SCOPE

The Standard describes the Standard Testing Procedure and Specifications, for the performance evaluation of Blood Gas Analyzers.

2. REFERENCES

The Standards listed below contain provisions which, through reference in this text, constitute provisions of this standard. At the time of publication, the editions indicated were valid. All standards are subject to revision, and parties to agreements based on this standard are encouraged to investigate the possibility of applying the most recent editions of the standards listed below.

<i>Indian Standard</i>	<i>Title</i>
IS/ISO 9000: 2015	Quality Management Systems - Fundamentals and Vocabulary (<i>fourth revision</i>)
IS/ISO 13485: 2016	Medical Devices - Quality Management Systems - Requirements for Regulatory Purposes (<i>first revision</i>)
IS/ISO 14971: 2019	Medical devices - Application of risk management to medical devices (<i>Under Print</i>)
IS 15393 (Part 3): 2003 ISO 5725-3: 1994	Accuracy (trueness and precision) of measurement methods and results - Part 3: Intermediate measures of the precision of a standard measurement method
IS/IEC 61010-1: 2010	Safety Requirements for Electrical Equipment for Measurement, Control, and Laboratory Use - Part 1 - General Requirements
MHD 19 (00318)/IS/IEC 61010-2-101: 2018	Safety requirements for electrical equipment for measurement, control and laboratory use - Part 2 - Section 101: Particular requirements for in vitro diagnostic (IVD) medical equipment (<i>Under print</i>)

3. TERMINOLOGY

For the purposes of this Standard, the following definitions shall apply:

3.1 pCO₂: The partial pressure (tension) of carbon dioxide in solution shall be defined as the partial pressure of carbon dioxide in the gas phase in equilibrium with the blood.

3.2 pO₂: The partial pressure (tension) of oxygen in solution shall be defined as the partial pressure of oxygen in the gas phase in equilibrium with the blood. pO₂ provides an indication of the availability of oxygen in the inspired air.

NOTE: Standard referenced used for measurement of Blood Gas are C 46-A2 Blood Gas and pH Analysis and Related Measurements, 2nd Edition

3.3 Hematocrit (Hct): Hematocrit (Hct) shall be defined as the percentage of red blood cells to the total blood volume.

3.4 Oxygen Saturation: Oxygen Saturation shall be defined as the amount of oxyhemoglobin in the blood expressed as a fraction of the total amount of hemoglobin able to bind oxygen.

3.5 Base excess of blood: Base excess of blood shall be defined as the concentration of titratable base needed to titrate blood to pH 7.40 at 37 °C while the pCO₂ is held constant at 40 mm Hg.

3.6 Standard Bicarbonate: Standard Bicarbonate shall be defined as the bicarbonate concentration of the plasma of whole blood equilibrated to a pCO₂ of 40 mmHg at a temperature of 37 °C with the hemoglobin fully saturated with oxygen.

3.7 Base Excess Extra-cellular fluid: Base Excess Extra-cellular fluid shall be defined as the corrected form of the Base Excess Blood in which allowance has been made for the fact that blood is only approximately 37% of the extra-cellular fluid volume.

3.8 Oxygen content: Oxygen content shall be defined as the total amount of oxygen contained in a given volume of whole blood, including dissolved oxygen and oxygen bound to hemoglobin.

3.9 Alveolar Oxygen: Alveolar Oxygen shall be defined as the partial pressure of oxygen in alveolar gas.

3.10 Accuracy: Closeness of agreement between a measured quantity value and a true quantity value of a measurand.

3.11 Calibration: Operation that, under specified conditions, in a first step establishes a relation between the quantity values with measurement uncertainties provided by measurement standards and corresponding indications with associated measurement uncertainties and, in a second step, uses this information to establish a relation for obtaining a measurement result from an indication. The process of testing and adjustment of an instrument, kit, or test system to provide a known relationship between the measurement response and the value of the substance being measured by the test procedure.

3.12 Quality Controls: Substance, material or article intended by its manufacturer to be used to verify the performance characteristics of an *in-vitro* diagnostic medical device;

NOTE: A device, material, solution, or lyophilized preparation intended for use in the quality control process. It should be similar to and analyzed along with patient specimens. If different, it should have a defined response to analytical measurements. Control materials may or may not have known measurand concentrations

(i.e. assigned values) within specified limits (E.g. target values, standard deviation). Control materials are not used for calibration purposes.

3.13 Calibrant: Measurement standard used in calibration.

NOTE: A reference material such as solution, suspension or device of known quantitative/qualitative characteristics such as concentration, activity, intensity, and reactivity used to calibrate, graduate, or adjust a measurement procedure or to compare the response obtained with the response of a test specimen/sample. The quantities of the measurands of interest in the Calibrant are known within limits ascertained during its preparation and may be used to establish the relationship of a measurement procedure's response to the characteristic measured for all methods or restricted to some. The calibrator must be traceable to a national or international reference preparation or reference material when these are available. Calibrants with different quantities of measurands may be used to establish a quantity/response curve over a range of interest.

[*SOURCE:* CLSI document H15]

3.14 In vitro diagnostic medical device: A device, whether used alone or in combination, intended by the manufacturer for the in vitro examination of specimens derived from the human body to provide information for the diagnosis, monitoring, or compatibility purposes. This includes reagents, calibrators, control materials, specimen receptacles, software, and related instruments or apparatus or other articles.

[*SOURCE:* IS/ISO 13485: 2016 Medical Device - Quality Management Systems - Requirements for Regulatory Purposes]

3.15 Linearity: Assuming no constant bias, the ability (within a given range) to provide results that are directly proportional to the concentration {amount} of the measurand in the test sample.

NOTE: Linearity Studies shall be executed with the reference standard.

[*SOURCE:* CLSI EP06-A - Evaluation of the Linearity of Quantitative Measurement Procedures; A Statistical Approach, 1st Edition]

3.16 Sample: One or more parts taken from a system, and intended to provide information on the system, often to serve as a basis for a decision on the system or its production.

NOTE 1: A sample is prepared from the patient specimen and used to obtain information by means of a specific laboratory test.

NOTE 2: For the purposes of this guideline the terms “sample” and “specimen” can be considered as equivalent.

NOTE 3: The term “Specimen” is used in laboratory medicine as a synonym for a sample, as defined here, of biological origin.

[*SOURCE:* GP 41 Collection of Diagnostic Venous Blood Specimens, 7th Edition]

3.17 Verification: Provision of objective evidence that a given item fulfills specified requirements.

NOTE 1: IS/ISO 9000 defines verification as confirmation, through the provision of objective evidence, that specified requirements have been fulfilled.

NOTE 2: In the context of this document, verification is the end-user laboratory's responsibility to ensure that the manufacturer's claims are correct.

3.18 Validation: Provision of objective evidence that given item fulfills specified requirements where the specified requirements are adequate for an intended use

NOTE 1: IS/ISO 9000 defines validation as confirmation, through the provision of objective evidence, that requirements for a specific intended use or application have been fulfilled;

NOTE 2: The World Health Organization (WHO) defines validation as “the action (or process) of proving that a procedure, process, system, equipment, or method used works as expected and achieves the intended result”;

NOTE 3: In the context of this document, validation is primarily a manufacturer's responsibility to ensure that design goals are met and performance claims are stated.

3.19 Specimen (patient): The discrete portion of body fluid or tissue taken for examination, study, or analysis of one or more quantities or characteristics to determine the character of the whole.

NOTE: Sample shall be collected as specified in GP 43-A4 standard - Procedures for the collection of Arterial Blood Specimens; Approved Standard - 4th edition.

3.20 Analytical Specificity: In quantitative testing the ability of a measurement procedure to determine only the measurand it purports to measure or the extent to which the assay responds only to all subsets of a specified measurand, and not to other substances present in the sample.

3.21 Precision: Closeness of agreement between indications or measured quantity values obtained by replicate measurements on the same or similar objects under specified conditions.

NOTE 1: Measurement precision is usually expressed numerically by means of imprecision, such as standard deviation, variance, or the coefficient of variation under the specified conditions of measurement (ISO/IEC Guide 99).

NOTE 2: The “specified conditions” can be, for example, repeatability conditions of measurement, or reproducibility conditions of measurement (IS 15393 (Part 3)/ISO 5725-3; ISO/IEC Guide 99).

NOTE 3: Measurement precision is used to define measurement repeatability, intermediate measurement precision, and measurement reproducibility (ISO/IEC Guide 99).

This Precision studies shall be carried out according to the standard CLSI EP05-A3 Evaluation of Precision of Quantitative Measurement Procedures.

3.22 Performance specification: A value or range of values for a performance characteristic, established or verified by the laboratory that shall be used to describe the quality of patient test results.

NOTE: Applicable standards: EP 07-A2 Interference Testing in Clinical Chemistry, 3rd Edition; EP 17-A2 Evaluation of Detection Capability for Clinical Laboratory Measurement Procedures, 2nd Edition

3.23 Performance characteristic: A property of a test that shall be used to describe its quality;

NOTE 1: Examples include accuracy, precision, detection limits, analytical specificity, and reference interval.

NOTE 2: A performance characteristic is a measurable quantity that can be given an experimentally determined value, such as trueness (bias), repeatability, standard deviation, or limit of detection.

3.24 Measuring Range: Set of values of quantities of the same kind that can be measured by a given measuring instrument or measuring system with specified instrumental uncertainty, under defined conditions (ISO/IEC Guide 99);

NOTE 1: In some fields, the term “measuring range” or “measurement range” (ISO/IEC Guide 99).

NOTE 2: The lower limit of a measuring interval should not be confused with a detection limit (ISO/IEC Guide 99).

NOTE 3: This represents the interval of in vitro diagnostic (IVD) examination results over which the performance characteristics of the IVD medical devices were validated by the manufacturer.

NOTE 4: Formerly the term “reportable range” was used in CLSI documents.

3.25 Risk Management and electrical Safety Blood Gas Analyzer: Blood Gas Analyzer is an Electronic equipment, with the possibility of risk is due to electronic short circuit. In this case, risk management and electronic safety requirements are necessary.

Manufacturers are generally required but not limited to comply with the following Standards of Safety:

NOTE 1: Standard IS/ISO 14971:2019 - Medical devices - Application of risk management to medical devices.

NOTE 2: IS/IEC 61010-1: 2010 Safety Requirements for Electrical Equipment for Measurement, Control, and Laboratory Use - Part 1 - General Requirements

NOTE 3: IS/IEC 61326-1: 2012 Electrical equipment for measurement, control and laboratory use - EMC requirements - Part 1: General requirements

NOTE 4: IS/IEC 61010-2-101: 2018 Safety requirements for electrical equipment for measurement, control and laboratory use - Part 2 - Section 101: Particular requirements for in vitro diagnostic (IVD) medical equipment

NOTE 5: IEC 61326-2-6: 2012 Electrical equipment for measurement, control and laboratory use - EMC requirements - Part 2-6: Particular requirements - In vitro diagnostic (IVD) medical equipment

4. PRINCIPLE

4.1 Measuring Principles

The measurement of Sodium (Na), Potassium (K), Ionized Calcium (iCa), Lithium (Li), Chloride (Cl), Bicarbonate (HCO_3), pH, pCO_2 , pO_2 , Hematocrit, and others. The Arterial Blood Gas Electrolyte Analyzer is widely based on the principle of the ion-selective electrode (ISE), using individual electrodes, sensor cartridges or others, as per the design and specifications of the manufacturer.

The typical processes/methods currently in use in Blood Gas Analyzer are mentioned below in figures 1 to 6. This has been provided as an illustration and may vary from model to model as per the design and specifications of the manufacturer.

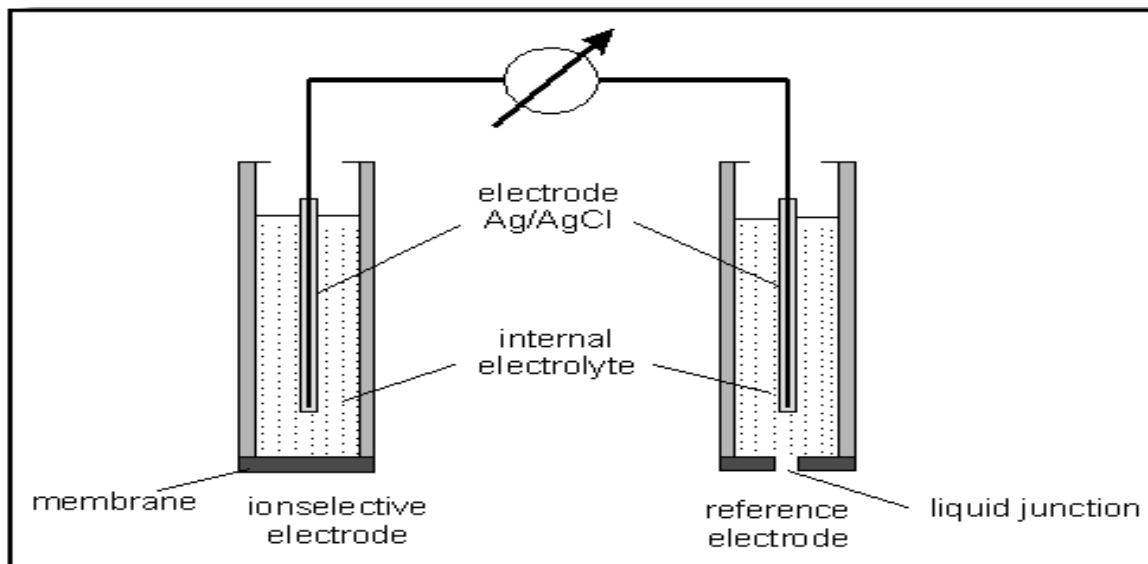

Figure 1: Quantitative, ion selective electrode technology (Clause 4.1)

Ion Selective Electrode: Ion Selective Electrode with the membrane at the end allows ions of interest to pass, but excludes the passage of the other ions.

The Internal reference electrode present within the ion-selective electrode shall be made of a silver wire coated with solid silver chloride, embedded in concentrated potassium chloride

solution (filling solution) saturated with silver chloride. This solution shall also contain the same ions as that to be measured.

Reference Electrode similar to ion-selective electrode, but there shall be no ‘to-be measured’ ion in the internal electrolyte.

Commonly used electrodes but not limited to - Calomel electrode/ silver/silver chloride electrode and others.

The lower end of the reference electrode shall be sealed with a porous ceramic frit which allows the slow passage of the internal filling solution and forms an external test solution.

Dipping into the filling solution shall be a silver wire coated with a layer of silver chloride joined to a low-noise cable connecting to the measuring system.

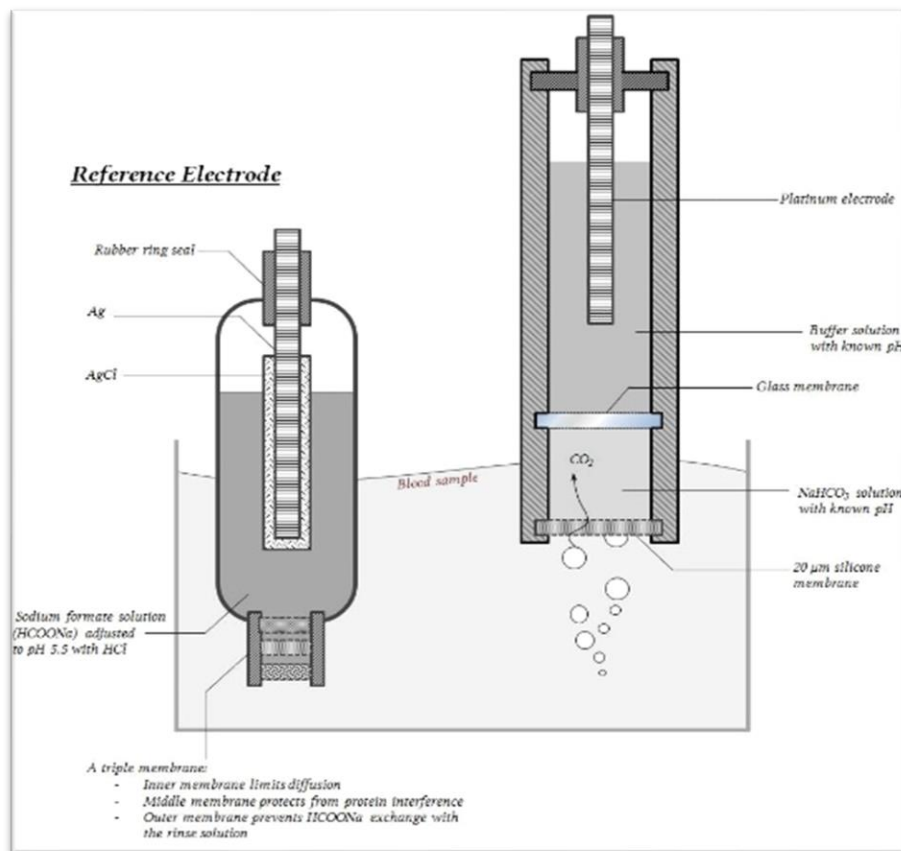
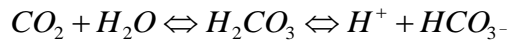

Figure 2: Quantitative: Traditional electrode technology (Clause 4.1)

The CO_2 dissolved in the sample shall diffuse into the middle compartment of the electrode via a thin membrane.

Once inside, the CO₂ shall be in an aqueous solution. For convenience, there may or may not be a bicarbonate solution added to this chamber. The reaction shall take place is a carbonic acid dissociation equilibrium:



Thus, the pH of the solution in the middle chamber changes. The change in pH shall be completely dependent on the pCO₂, provided the temperature and pressure remain constant:

$$pH = pK_a + \log \frac{cHCO_3^-}{pCO_2 \times \alpha_{CO_2}}$$

pK_a: dissociation equilibrium constant for the dissociation of carbonic acid in water.

α_{CO₂} : solubility coefficient for CO₂ in water

This shall result change in potential difference in the glass electrode; thus, from the change in pH, pCO₂ shall be calculated.

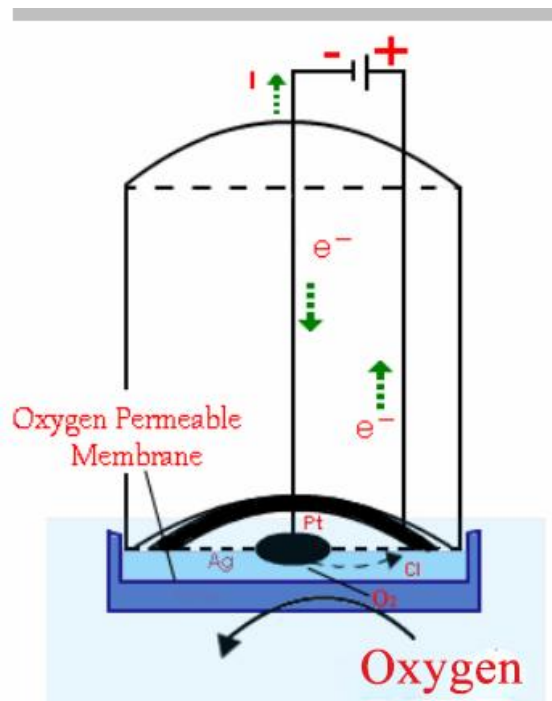

Figure 3: Amperometric technology (Clause 4.1)

A potential shall be applied between the central platinum cathode and the annular silver anode. This shall generate a current (I) passing through the electrodes by means of a saturated solution of KCl. This electrode compartment shall be separated by a thin plastic membrane, permeable

only to oxygen. This Oxygen electrode shall be normally about 1 cm in diameter but has been scaled down to 0.25 mm diameter using a Pt wire cathode within a silver-plated steel needle anode and utilizing dip-coated membranes.

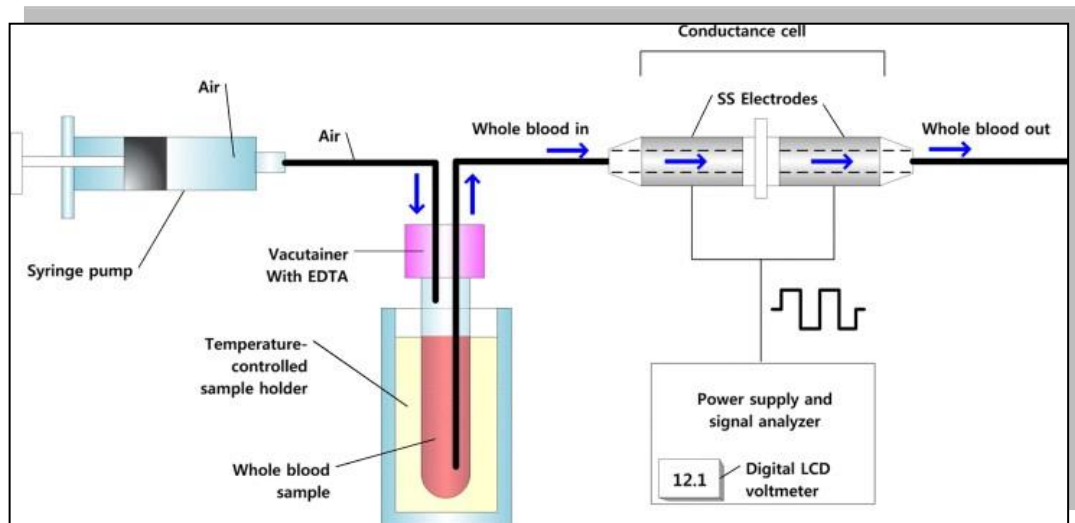

Figure 4: Conductivity method (Clause 4.1)

The conductivity is the ability of a solution to transmit (conduct) electricity. The electrical current shall increase in proportion to the number of ions (or charged particles) found in a solution, their electrical charge, and mobility, i.e. how easily the ions can move in the solution. The mobility of an ion in a solution should also depend on the number of cells, their size, and shape, suspended in the solution.

Both erythrocytes and plasma have characteristic electrophysical properties. The membrane of the erythrocytes is electrically insulating, mainly due to its content of lipids, so that it appears essentially non-conducting.

Plasma is fairly conductive due to its content of electrolytes and charged proteins; the major contributor to plasma conductivity is Na^+ , the concentration in human blood plasma being approx. 140 mmol/L.

Due to this, there is an inverse relationship between the electrical conductance and the hematocrit in blood when the concentration of the charged particles is taken into account.

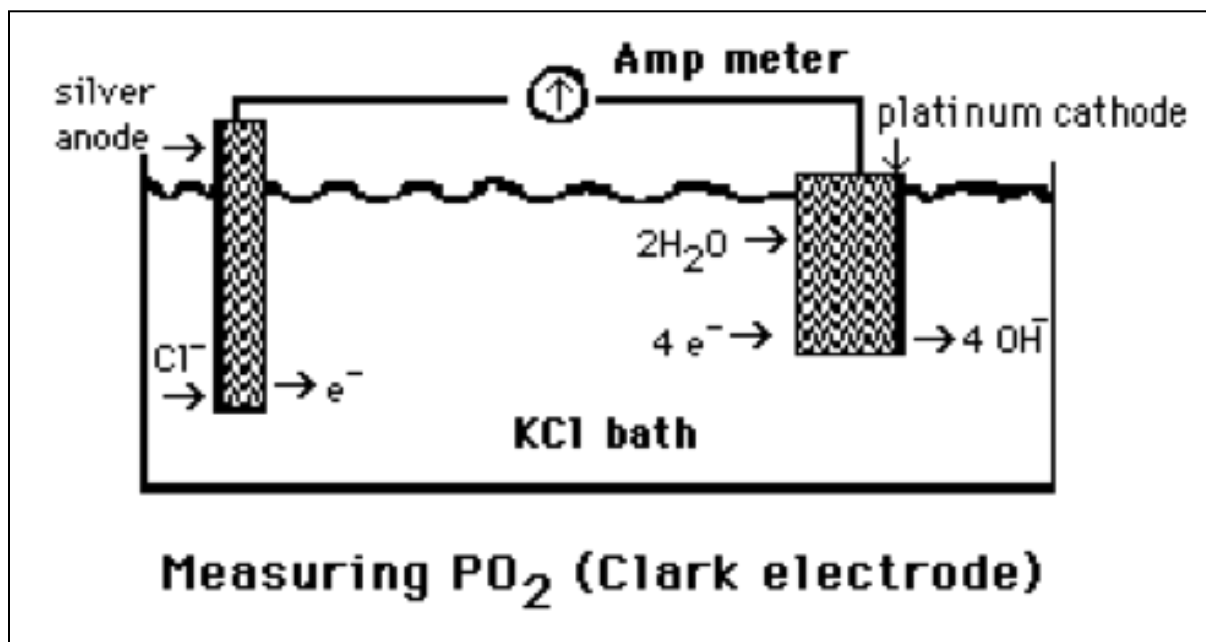

Figure 5: Amperometry (Clause 4.1)

The electrode has several components: a platinum cathode (electron receiver), silver anode (electron donor), electrolyte solution (typically KCl), semi-permeable membrane and a voltage source. The silver anode shall be submersed in the electrolyte solution, typically KCl. The silver interacts with the KCl to produce the following reaction:



The platinum cathode shall utilize the electrons produced from this reaction to reduce the oxygen from the sample being tested via the following equation:



More the oxygen available to carry out the reaction, the greater shall be the flow of electrons (i.e. a higher current). Therefore, the Clark electrode should use Amperometry to determine the oxygen tension of the sample.

The Overall reaction is as follows:



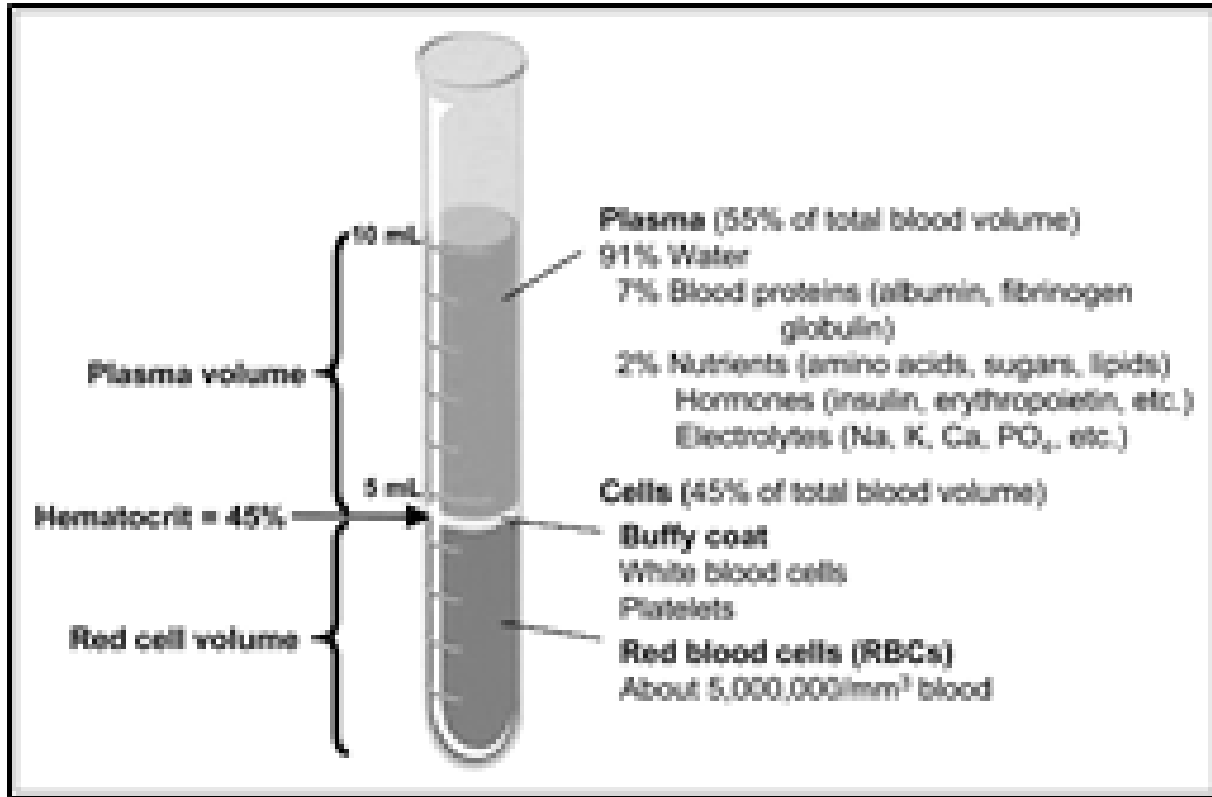

Figure 6: Earlier method of Hematocrit estimation (Clause 4.1)

Hematocrit (PCV) is the measure of the ratio of the volume occupied by the red blood cells to the volume of whole blood. The blood sample shall be drawn into a capillary and centrifuged, and then the ratio should be measured and shall be expressed as a decimal or percentage fraction.

4.2 Sodium, Potassium, Chloride and Ionized Calcium - Principle of Measurement

In an ion-selective electrode, an electrical potential should be established across a membrane that is selective to a specific ion. Such electric potential of the ion-selective electrode shall be measured against a reference electrode and it shall be used to determine the activity (a) or effective concentration (c) of the ion of interest in a sample.

4.2.1 The electrical potential (E) of the ion-selective electrode measured against the reference electrode can be described by the following Nernst equation.

$$E = E^{\circ} + \frac{RT}{nF} \log(a_c)$$

Where

- E = the potential of the electrode in sample solution
- E° = the potential developed under standard conditions
- RT/nF = A temperature dependent “constant” termed the slope (s)
- n = 1 for sodium, potassium, chloride, lithium and pH

n	=	2 for calcium
Log	=	Base ten logarithm function
a	=	Activity coefficient of the measured ion in the solution
c	=	Concentration of the measured ion in the solution

4.2.2 The Nernst equation above can be simplified as follows:

$$E = E' + S \cdot \log (C)$$

The standard electrical potential (E') and slope (S) shall be determined by measuring the electrical potentials of the ion-selective electrode in two calibration solutions that have known concentrations of the measuring ions at different levels. This process has been defined as two-point calibration. Once the E' and S are determined, the unknown concentration of a sample should be determined by measuring the electric potential of the electrode in a sample.

4.3 Partial Pressure of Carbon Dioxide (pCO₂)

4.3.1 pCO₂ should be measured with a modified pH sensor. As carbon dioxide in the unknown solution make contact with a hydrogen ion selective membrane, CO₂ should diffuse across the membrane into a thin layer of bicarbonate buffer in response to partial pressure difference. This solution then becomes equilibrated with the external gas pressure of the fluid in contact with the outer surface of the membrane. CO₂ in the solution becomes hydrated producing carbonic acid which results in a change in hydrogen ion activity.

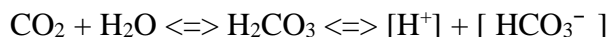

4.3.2 The pH of this internal solution varies with the pCO₂ according to the *Henderson-Hasselbalch* equation as stated below:

$$\text{pH} = \text{pKa} + \log \{ \text{HCO}_3^- / \text{pCO}_2 * a \}$$

The measured potential shall be related to the logarithm of pCO₂ content of the sample after compensation of the measured potential of the pH sensor.

4.4 Partial Pressure of Oxygen (pO₂)

pO₂ shall be measured amperometrically by the generation of current at the sensor surface. As oxygen diffuses through a gas-permeable membrane, the oxygen molecules are reduced at the cathode, consuming 4 electrons for every molecule of oxygen reduced. This flow of electrons shall be then measured by the sensor and it should be directly proportional to the partial pressure of oxygen.

4.5 Hematocrit (Hct)

Hematocrit shall be obtained by measuring the electrical resistance of the blood sample. Two standard solutions should be used to calibrate the hematocrit sensor and obtaining the slope. The analyzer shall then measure the electrical resistance of the blood sample to obtain the hematocrit value. The hematocrit value obtained shall be corrected for the concentration of the sodium ion.

4.6 Glucose

Glucose measurement shall be based on the level of H₂O₂ produced during the enzymatic reaction between glucose and oxygen molecules in the presence of the glucose oxidase enzyme. The reaction is described by the following equation:

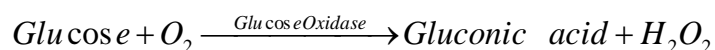

At a constant potential of 0.70 volts, electro-active H₂O₂ gets oxidized at the surface of the anode as follows:

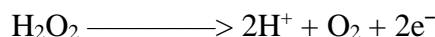

The current generated by the flow of electrons at the surface of the strip shall be proportional to the glucose concentration of the sample.

4.7 Lactate

Lactate measurement shall be based on the level of H₂O₂ produced during the enzymatic reaction between lactate and oxygen molecules in the presence of the lactate oxidase enzyme.

The reaction is described by the following equation:

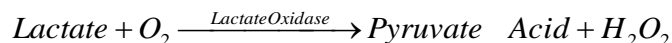

At a constant potential of 0.70 volts, electro-active H₂O₂ gets oxidized at the surface of the anode as follows:

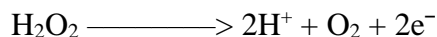

The current generated by the flow of electrons at the surface of the strip shall be proportional to the lactate concentration of the sample.

4.8 Calculated Values

The analyzer's microcomputer shall use the measured results to calculate other clinically relevant parameters. This section outlines the equations used to calculate these values. The following has been provided as an illustration. The calculations and equations may vary from model to model.

4.8.1 Temperature Correction for Measured Values

The Arterial Blood Gas Analyzer shall allow the input of the patient temperature when this differs from 37 °C, as for example in patients having surgery under hypothermia. The pH, pCO₂, and pO₂ sample values, at the patient's actual temperature, are then calculated as follows:

4.8.1.1 $pH \text{ (corrected)} = pH + [- 0.0147 + 0.0065 (7.400 - pH)](T - 37)$

4.8.1.2 $pCO_2 \text{ (corrected)} = pCO_2 \times e (0.04375(T - 37))$

4.8.1.3 $pO_2 \text{ (corrected)} = pO_2 \times 10U$

4.8.1.4
$$U = \left(\left[\frac{(5.49 \times 10^{11})Y + 0.071}{(9.72 \times 10^{-9})Y + 2.30} \right] \times (T - 37) \right)$$

Where, $Y = e [3.88 \times \ln(pO_2)]$

4.9 Calculated Parameters

4.9.1 Calculated Bicarbonate Concentration [HCO₃⁻]*

4.9.1.1 Bicarbonate Concentration (mmol/L) shall be calculated using the Henderson-Hasselbalch equation:

$$pH = pK + \log \frac{[HCO_3^-]}{\alpha(PCO_2)}$$

Where, pH and pCO₂ are measured.

pK = 6.091; **α** = 0.0307 = solubility coefficient of CO₂ in plasma at 37 °C and referring

$$\log_{10} [HCO_3^-] = pH + \log_{10} pCO_2 - 7.604$$

4.9.2 Total Carbon Dioxide Content (TCO₂)*

TCO₂ (mmol/L) includes both dissolved carbon dioxide and [HCO₃⁻] and shall be calculated as follows:

$$TCO_2 = [HCO_3^-] + \alpha (pCO_2)$$

Where, pCO₂ shall be measured and [HCO₃⁻] shall be calculated from the above equation.

4.9.3 Hemoglobin (Calculated)

The hemoglobin shall be calculated based on the following calculation:

$$\text{Hemoglobin g/dL} = (\text{Measured Hematocrit} / 3.0)$$

CAUTION: The Blood Gas Analyzer provides an estimation of hemoglobin only from normal hematocrit values citing the specific normal adult male/female range. In cases of abnormal blood composition, e.g., red cell dyscrasia or hemoglobinopathies or in cases of disease states, e.g., anemia, repeat testing by conventional laboratory methods is indicated.

NOTE: The hemoglobin calculation is an estimation based on a normal mean corpuscular hemoglobin concentration of 33.3% and a nominal male Hct of 39 to 49% or female Hct of 35 to 45%. Hemoglobin estimations made from samples with Red cell dyscrasia or hemoglobinopathies may vary significantly from hemoglobin measured by the cyanmethemoglobin method. The estimated hemoglobin may vary significantly in cases of abnormal blood composition or disease states such as anemia in which abnormal values may not be reported. These conditions should warrant repeat testing by conventional laboratory methods.

4.9.4 Base Excess of Blood (BE-B) *

Base excess of blood shall be calculated as follows:

$$\text{BE-B} = (1 - 0.014[\text{Hb}]) ([\text{HCO}_3^-] - 24 + (1.43[\text{Hb}] + 7.7) (\text{pH} - 7.4))$$

4.9.5 Standard Bicarbonate Concentration (SBC)

Standard bicarbonate shall be calculated as follows:

$$\text{SBC} = 24.5 + 0.9Z + Z(Z - 8)(0.004 + 0.00025 [\text{Hb}])$$

Where, $Z = [\text{BE-B}] - 0.19 [\text{Hb}] ((100 - \text{SO}_2)/100)$

[Hb] = The hemoglobin value which shall be measured, manually entered, or 14.3 g/dL as default value.

4.9.6 Base Excess Extracellular Fluid (BE-ECF) *

Base excess extracellular fluid shall be calculated as follows:

$$\text{BE-ECF} = [\text{HCO}_3^-] - 25 + 16.2 (\text{pH} - 7.40)$$

4.9.7 Oxygen Content (O₂Ct)

As defined in section 3.8, oxygen content shall be expressed in milliliters of oxygen per 100 milliliters of blood (volume %) as calculated from the oxygen saturation and the hemoglobin concentration. Four moles of oxygen (22,393 mL/mol at standard temperature and pressure) can combine with 1 mole of hemoglobin (64,458 g/mol) so that oxygen capacity is equal to as follows:

$$\frac{4(22393)}{64458} = 1.39 \text{ mL } O_2 \text{ per gram of Hb}$$

Therefore,

$$O_2Ct = (1.39 [\text{Hb}]) (\text{SO}_2/100) + (0.0031 [\text{pO}_2])$$

Where 0.0031 is the solubility coefficient of O₂.

On the analyzer, hemoglobin can be manually entered, calculated from the measured hematocrit, or occur as a default value.

4.9.8 Oxygen Saturation (SO₂)

Oxygen saturation shall be calculated as follows:

$$SO_2 = \frac{[PO_2']^3 + 150[PO_2']}{[PO_2']^3 + 150[PO_2'] + 23400} \times 100$$

Where, $[PO_2'] = [PO_2] \times e [2.3026 \times (0.48 (\text{pH} - 7.4) - 0.0013([\text{HCO}_3^-] - 25))]$

NOTE: The equation for calculating oxygen saturation assumes a normal shape and position of the patient's oxygen dissociation curve.

4.9.9 Alveolar Oxygen (A)

Alveolar Oxygen shall be calculated as follows:

$$A = \frac{\% FIO_2}{100} (B.P. - 0.045T^2 + 0.84T - 16.5) - ** PCO_2 \left[\frac{\% FIO_2}{100} + \left(\frac{1 - (\% FIO_2 / 100)}{0.8} \right) \right]$$

Where, T = patient temperature, B.P. = barometric pressure, %FIO₂ = fraction inspired oxygen, as a percent, ** Temperature corrected gas value

4.9.10 Arterial Alveolar Oxygen Tension Gradient (AaDO₂)

The arterial alveolar oxygen tension gradient is a useful index of gas exchange within the lungs and shall be calculated as:

$$Aa DO_2 = A - **PO_2$$

Where ** Temperature corrected gas value

NOTE: For capillary samples, AaDO₂ results have an asterisk (*). AaDO₂ results are dependent on how the samples are drawn and handled, thus care must be taken when interpreting these calculated results.

4.9.11 Arterial Alveolar Oxygen Tension Ratio (a/A)

The arterial alveolar oxygen tension ratio is useful to predict oxygen tension in alveolar gas and to provide an index of oxygenation which remains relatively stable when FIO₂ changes. It shall be calculated as follows:

$$a/A = \frac{P_{aO_2}}{P_{A_{O_2}}}$$

Where $P_{A_{O_2}}$ Temperature corrected gas value

4.9.12 Ionized Calcium Normalized to pH 7.4

The activity and concentration of ionized calcium in whole blood is pH dependent. In vitro, a pH increase of 0.1 unit decreases the ionized calcium level by 4 to 5% (conversely, a pH decrease has an equal but opposite effect). The sample of choice for ionized calcium determination should be anaerobically collected whole blood.

If an anaerobic sample is not available, by measuring the actual pH of the sample at which the ionized calcium concentration was measured normalized ionized calcium can be calculated. The normalized ionized calcium represents what the ionized calcium concentration would have been if the initial pH was 7.40 (the midpoint of the pH reference range).

The equation used for this calculation is as follows:

$$\log [iCa]_{7.4} = \log [Ca^{++}]_X - 0.24 (7.4 - X)$$

Where X = measured pH of the sample, $[Ca^{++}]_X$ = ionized calcium concentration in the sample at the measured pH and $[iCa]_{7.4}$ = normalized concentration of ionized calcium at pH 7.40.

The equation assumes a normal concentration of total protein and may be used for measured values between pH 7.2 and 7.6. Between pH 6.9 and 7.2 and between pH 7.6 and 8.0, modified forms of the equation are used. Normalized ionized calcium values for samples with pH outside the range pH 6.9 to pH 8.0 are not displayed.

4.9.13 Anion Gap

Anion gap shall be calculated as the difference between the sum of the sodium and potassium concentrations (the cations) and the sum of the chloride and bicarbonate concentrations (the anions), as follows:

$$\text{Anion Gap} = (Na + K) - (Cl + [HCO_3^-])$$

No anion gap should be reported if any of the 4 concentrations are not reported. Any calculated anion gap less than 10 mmol/L shall not be considered as valid.

5. OPERATOR MENU FLOW CHART

The following has been provided as an illustration. The design and flow chart/s may vary from model to model depending upon the claims and specifications of the manufacturer.

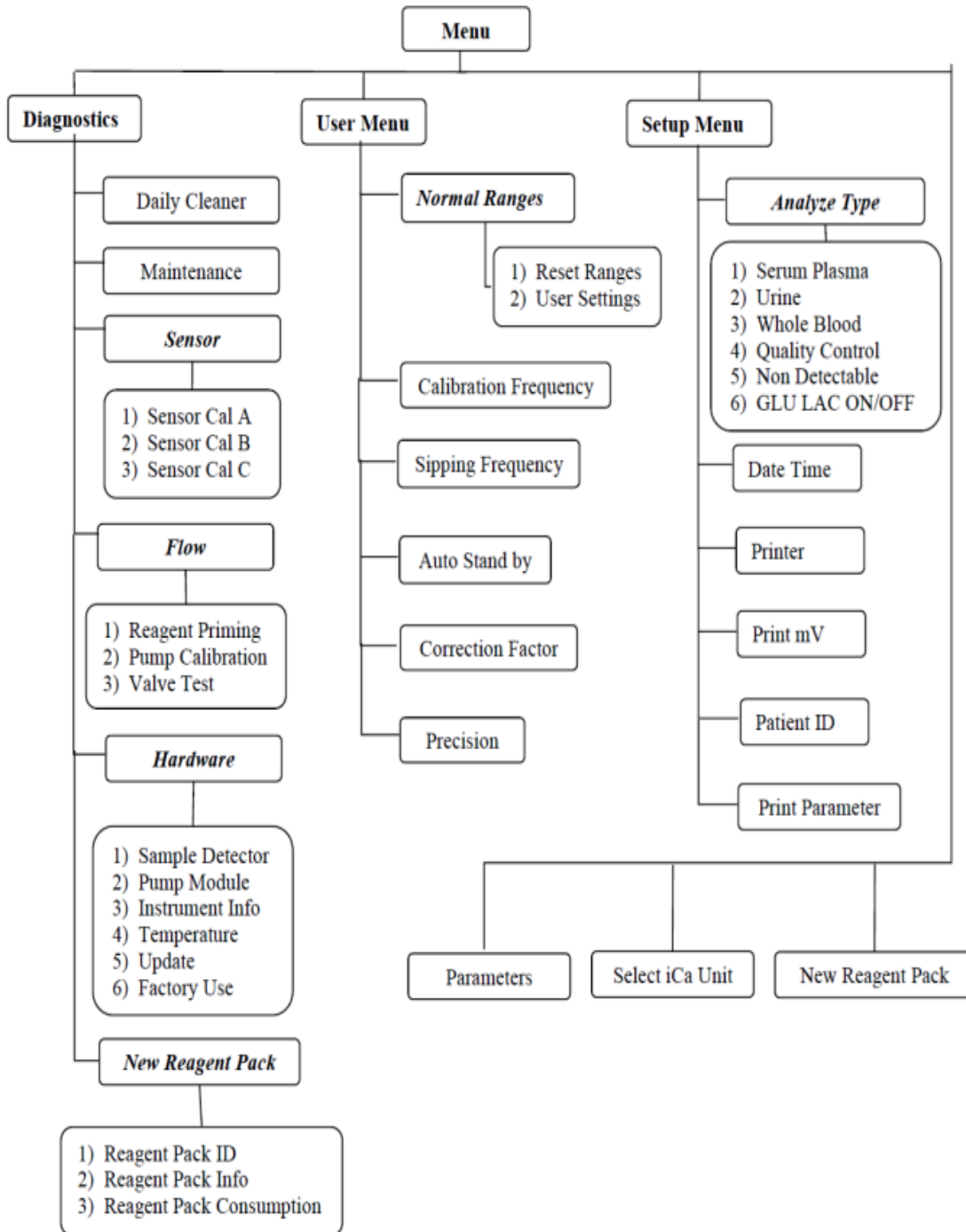

- 5.1** Menu should provide a list of commands which display on the screen such as Diagnostics, User Menu and Setup menu.
- 5.2** Diagnostics Menu consists of Daily Cleaner, Maintenance, Sensor, Flow, Hardware and New Reagent Pack.
- 5.2.1** Daily Cleaner menu helps to activate the Daily Cleaner mode to remove deposition in the fluid path.
 - 5.2.2** Maintenance menu helps to enter into maintenance mode when changing electrodes or tubes/ cleaning the instrument or if any dis-assemblies.
 - 5.2.3** Sensor menu can be used to check mV of the electrodes of each reagent separately.
 - 5.2.4** Flow menu can be used for initializing or troubleshooting flow issues in the instrument.
 - 5.2.5** Hardware menu can be used for checking the functionality of modules used in an instrument such as a bubble detector Pump Module.
 - 5.2.6** New reagent pack menu shows the information of reagent pack like consumption, reagent pack lot no or pack volume & information about CAL A, CAL B concentration.
- 5.3** **User Menu** consists of Normal Ranges, Calibration frequency, Sipping Frequency, Auto Stand by, Correction Factor and Precision Menus
- 5.3.1** Normal **ranges** menu can be used for setting the ranges of QC and Urine Controls.
 - 5.3.2** Calibration **Frequency** can be used to set auto calibration frequency to either 4 hours or 8 hours.
 - 5.3.3** Sipping **Frequency** can be used to set Sipping frequency to either 30 minutes or 1 Hour.
 - 5.3.4** Auto **Standby** mode allows users to set auto-standby ON or OFF state.
 - 5.3.5** **Correction Factor** mode allows the user to set the correction factor for each and every parameter.
 - 5.3.6** **Precision** mode helps the user to calculate the precision results.
- 5.4** **Setup menu** consists of Analyze Type, Date-Time, Printer, Print mV, Patient ID, Print Parameter.

5.4.1 Analyze type menu helps to select the sample to analyze modes such as serum plasma, urine, whole blood, Quality Control, Non-Detectable or Glu/Lac.

5.4.2 Date and Time mode helps the user to set date and time.

5.4.3 Printer mode helps the user to print output data or not.

5.4.4 Print mV mode helps the user to select the printing data in mV or not.

5.4.5 Patient ID mode helps the user to fill the patient details.

5.4.6 Print Parameter mode helps to print only the selected parameter.

6. PERFORMANCE SPECIFICATIONS AND CHARACTERISTICS

6.1 Analytical performance

6.1.1 Precision/Reproducibility

Precision testing shall be performed in accordance with CLSI EP05-A3 or as per extant guidelines. The primary objective of this test should be to check the performance of the reagent pack in analyzing the test samples accurately by producing repeated and reproducible test results for continuous 3 days. If the Three reagent packs analyze the test samples (Quality Control level 1,2,3 and Third-Party Controls consistently in 3 different instruments for 20 times a day for 3 continuous days, the reagent pack can be said to be consistent in analyzing the sample repeatedly with no deviation.

After a calculated measure, if the value of CV is below 3, the reagent pack shall be considered to be efficient in analyzing the test sample and hence the reagent pack lot should be considered to be validated and accepted. If the CV value ranges more than 3, the reagent solution shall be considered inefficient and the complete lot shall be rejected with a note of inefficiency in analyzing the test sample.

6.1.2 Linearity/assay reportable range

The linearity studies should be performed following the CLSI EP06-A guideline. For the three electrolytes and others, ten to eleven equally spaced concentrations covering the measurement range should be prepared by mixing high and low concentration samples.

Four replicates should be measured for each sample. The observed values should be plotted against the expected values and linear regression analysis should be performed. The summary results are provided in Table 1 shown below.

Table 1: Summary results of Linearity/assay reportable range (Clause 6.1.2)

Analyte in Blood	Measuring Range	Suggested CV (%)
Na ⁺	20.0 - 250.0 mmol/L	< 3%
K ⁺	0.20 - 40.00 mmol/ L	
Cl ⁻	25.0 - 200.0 mmol/L	
iCa ⁺⁺	1.0 - 20.0 mmol/L	
Li ⁺	0.2 - 5 mmol/L	
pH	6 – 8	
pO ₂	10 - 750 mmHg	
pCO ₂	5 - 120 mmHg	
TCO ₂	5 - 50 mmol	
Hct	10 - 70%	
HCO ₃	5 - 50 mmol	

The results of the linearity study support the sponsor’s claimed measuring ranges (as described in the table above).

6.1.3 Traceability, Stability, Expected values (controls, calibrators, or methods):

6.1.3.1 The Blood Gas Analyzer Na assay should be traceable to a flame emission spectrophotometry / UV-VIS spectroscopy (Bio-Chemistry) or any other recognized reference method, which uses standard/certified reference materials.

6.1.3.2 The Blood Gas Analyzer K assay should be traceable to a flame emission spectrophotometry / UV-VIS spectroscopy (Bio-Chemistry) or any other recognized reference method, which uses standard/certified reference materials.

6.1.3.3 The Blood Gas Analyzer Cl assay should be traceable to a Coulometric or any other recognized reference method, which uses standard/certified reference materials.

6.1.3.4 The Blood Gas Analyzer iCa assay should be traceable to a flame emission spectrophotometry / UV-VIS spectroscopy (Bio-Chemistry) or any other recognized reference method, which uses standard/certified reference materials.

6.1.3.5 The Blood Gas Analyzer Li assay should be traceable to a flame emission spectrophotometry / UV-VIS spectroscopy (Bio-Chemistry) or any other recognized reference method, which uses standard/certified reference materials.

6.1.3.6 The Blood Gas Analyzer pH assay should be traceable to a flame emission spectrophotometry / UV-VIS spectroscopy (Bio-Chemistry) or any other recognized reference method, which uses standard/certified reference materials.

6.1.3.7 The Blood Gas Analyzer pCO₂/HCO₃ assay should be traceable to a flame emission spectrophotometry / UV-VIS spectroscopy (Bio-Chemistry) or any other recognized reference method, which uses standard/certified reference materials.

6.1.3.8 The Blood Gas Analyzer pO₂ assay should be traceable with reagents for pO₂ which uses standard/certified reference materials.

6.1.3.9 The Blood Gas Analyzer Glucose assay should be traceable with glucose standards and reagents, which uses standard/certified reference materials.

6.1.3.10 The Blood Gas Analyzer Hct assay should be traceable to a commercially available reference method, which is a micro-hematocrit method.

6.1.3.11 The Stability of the Blood Gas Analyzer Reagent shall be evaluated as per EP 25-A.

7. SPECIFICATIONS

7.1.2 Analytical specificity:

Arterial Blood Gas Analyzer reagent packs should be validated for analytical specificity, which is the ability of an assay to measure a particular substance rather than others in a sample. Analytical specificity is demonstrated on part of Analytical performance studies. In addition to that, Arterial Blood Gas Analyzer works on an ion-selective method where its electrodes are selective to particular ion only.

The reagent should undergo the test process by performing the test for 20 times a day with test samples as Quality Levels (Level 1, 2 and 3) and External Controls Level 1 and Level 2. The test sample solution should be prepared by using different chemicals and their composition. The reagent pack should be capable of analyzing and evaluating the test sample for the required

chemical content to prove that the analytical studies performed in the aspect of analytical specificity are acceptable.

7.1.3 Comparison studies:

Method comparison studies should be performed following CLSI EP09-A3. A quality control samples of different levels shall be run in three arterial blood gas Analyzer for three days simultaneously with predicate device and the results were compared to those obtained on the predicate device.

7.1.4 Expected values/References range:

Reference ranges of pH, pO₂, pCO₂, HCT, SO₂, Hb, Na⁺, K⁺, iCa⁺⁺, Li⁺, Cl⁻, HCO₃⁻, TCO₂, SBC, BE, BE-B, BE-ECF, AG_Na, AG_K- are cited from literature in the below table.

[SOURCE: 1. Buche, J Neonatal Biol. 2014, 3:4, DOI: 10.4172/2167-0897.1000153; 2. Biochemia Medica 2016; 26 (3) : 318–36]

Table 2: Reference range (Clause 7.1.4)

Parameter	Reference Ranges	Unit
pH	7.35 -7.45	N.A.
pO ₂	83.0 - 108.0	mmHg
pCO ₂	35.0 - 48.0	mmHg
HCT	38 - 51	%
SO ₂	94.0 - 98.0	%
Hb	12 - 17	g/dL
Na ⁺	138 - 146	mmol/L
K ⁺	3.5 - 4.5	mmol/L
iCa ⁺⁺	1.15 - 1.33	mmol/L
Li ⁺	0.3 - 1.5	mmol/L
Cl ⁻	98 - 107	mmol/L
HCO ₃ ⁻	21.0 - 28.0	mmol/L
TCO ₂	22.0 - 29.0	mmol/L
SBC	21.0 - 26.0	mmol/L
BE	2.0 - 3.0	mmol/L
BE-B	2.0 - 3.0	mmol/L
BE-ECF	3.0 - 3.0	mmol/L
AG_Na	7.0 - 16.0	mmol/L
AG_K	10.0 - 20.0	mmol/L

8. MARKING

8.1 Compliance Marking

Each Blood Gas Analyzer shall display a label which contains all the information, in compliance with the regulatory requirements¹, but not limited to the following:

- a) Product Name
- b) Voltage
- c) Storage Temperature
- d) For in- vitro Diagnostics use only.
- e) Batch No. / Lot No. / unique ID
- f) Manufacturer's complete name & address
- g) Marketer's (if any) complete name & address
- h) Manufacturing Month
- i) Cautions
- j) Relevant symbols

8.2 BIS Certification Marking

The product(s) conforming to the requirements of this standard may be certified as per the conformity assessment schemes under the provisions of the *Bureau of Indian Standards Act, 2016* and the Rules and Regulations framed thereunder, and the product(s) may be marked with the Standard Mark.

9. PACKAGING / TRANSPORTATION STANDARDS

The packaging and transportation of the Blood Gas Analyzer must comply with ASTM D4169-16 Standard and/or other relevant standards as applicable to the analyzer on the basis of manufacturer's specifications and claims.