

BUREAU OF INDIAN STANDARD

DRAFT FOR COMMENTS ONLY

(Not to be reproduced without permission of BIS or used as an Indian Standard)

भारतीय मानक मसौदा
गाइड, आरी, डी मार्टेल पैटर्न के लिए विशिष्टता
(IS 8696 पहला पुनरीक्षण)

Draft Indian Standard
Specification For Guide, Saw, De Martel's Pattern
(First Revision of IS 8696)

[ICS 11.040.30]

Neurosurgery Instruments, Implants and
Accessories Sectional Committee, MHD-07

Last date for comments: **17 July 2024**

FOREWORD

(Formal clause will be added later)

This standard was originally published in 1978. This revision includes minor changes in references to incorporate the updated designation of steel and the currently used methods of test for hardness and corrosion resistance.

For the purpose of deciding whether a particular requirement of this standard is complied with the final value, observed or calculated, expressing the result of a test or analysis shall be rounded off in accordance with IS 2: 2022 'Rules for Rounding Off Numerical Values (*Second Revision*)'. The number of significant places retained in the rounded off value should be same as that of the specified value in this standard.

1 SCOPE

These standard covers material, dimensions and other requirements for De Martel's pattern saw guide in two sizes used in neurosurgery.

1 REFERENCES

The standard given below contain provisions which, through reference in this text, constitute provisions of this standard. At the time of publication, the editions indicated were valid. All standards are subject to revision, and parties to agreements based on this standard are encouraged to investigate the possibility of applying the most recent editions of these standards.

<i>IS No.</i>	<i>Title</i>
IS 6911: 2017	Stainless Steel Plate, Sheet and Strip — Specification (<i>Second Revision</i>)
IS 7531: 1990	Methods for testing of corrosion resistance of stainless-steel surgical instruments (<i>First Revision</i>)

2 MATERIAL

The components shall be made of stainless steel strip conforming to Designation X30Cr13 of IS 6911: 2017

3 SHAPE AND DIMENSIONS

Shall be as shown in Fig. 1

A deviation of ± 2.5 percent shall be allowed on all dimensions.

4 WORKMANSHIP AND FINISH

4.1 The guide shall be of one-piece construction and shall be free from burrs, pits, cracks and other surface defects. It shall have a gentle inside curve, concave towards the hook side as shown in Fig, 1. The front end or tip shall be suitably thickened by means of silver soldering as shown in Fig, 1.

4.2 The hook for wire saw shall be punched out of strip and formed in the shape as shown in Fig, 1. It shall be sufficiently strong and shall not be liable to yield or break up during use.

4.3 All edges of the guide, including the hook for wire saw, shall be evenly rounded and shall be nowhere sharp. The silver soldering shall be clean and sound.

4.4 The guide shall be polished bright and passivated.

5 HEAT TREATMENT

The guide shall be suitably hardened and tempered to give a uniform hardness of 400 to 450 HV

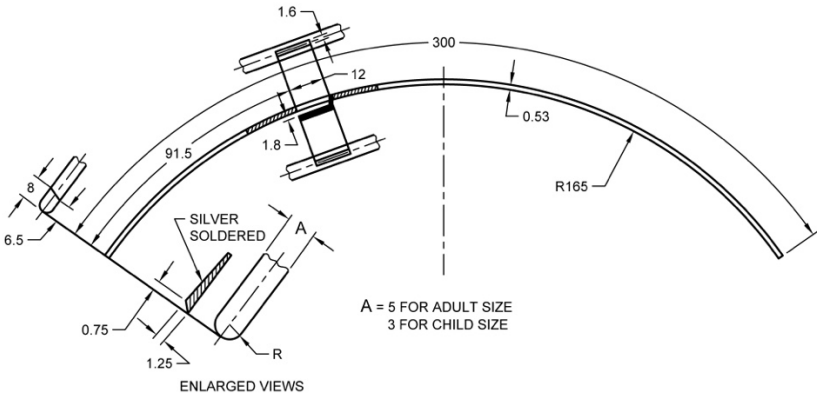

All dimensions in millimetres.

FIG. 1 GUIDE, SAW, DE MARTEL'S PATTERN

6 TESTS

6.1 Flexibility Test — Bring two ends of the guide closer towards the concave side, to a distance of 50 mm from each other and release them, Repeat it five times. As a result of this test, the guide shall not acquire a permanent set.

6.2 Load Test - Holding the guide vertically, hang a load of 20 N from the guide hook for a period of 5 minutes. The hook shall not yield or open up during the test.

6.3 Corrosion Resistance - The guide shall conform to the requirements of IS 7531:1990.

7 MARKING

7.1 Each guide shall be marked by etching or otherwise with the manufacturer's name, initials or recognized trade-mark, along with its size, that is, 'Adult' or 'Child' as the case may be.

7.2 BIS Certification Marking

The product(s) conforming to the requirements of this standard may be certified as per the conformity assessment schemes under the provisions of the Bureau of Indian Standards Act, 2016 and the Rules and Regulations framed thereunder, and the product(s) may be marked with the Standard Mark.

8 PACKING

The guide shall be packed in a polyethylene cover. It may also be packed as agreed to between the purchaser and the supplier. On the package of the product batch Number, Lot Number, and Serial Number shall be mentioned.

9 PACKING

The guide shall be packed in a polyethylene cover. It may also be packed as agreed to between the purchaser and the supplier