

**BUREAU OF INDIAN STANDARDS**

**DRAFT FOR COMMENTS ONLY**

*(Not to be reproduced without permission of BIS or used as an Indian Standard)*

---

**भारतीय मानक मसौदा**  
**पुनः श्वसन को रोकने वाले वाल्व की विशिष्टि**  
**भाग २ अम्बु - हेस्से प्रतिरूप**  
**(पहला पुनरीक्षण IS 8254 (Part 2) का)**

***Draft Indian Standard***  
**Specification for Valve, Non-Rebreathing**  
**Part 2 Ambu-Hesse's Pattern**  
***(First Revision if IS 8254 (Part 2))***

**[ICS 11.040.10]**

---

Anaesthetic, Resuscitation and Allied  
Equipment Sectional Committee, MHD 11

Last Date for comments: **27 June, 2023**

---

FOREWORD

*(Formal clause will be added later)*

This Indian Standard was originally published in 1976 as Specification for Valve, Non-Rebreathing Part 2 Ambu-Hesse's Pattern. This First Revision has been taken up to align with latest practice.

For the purpose of deciding whether a particular requirement of this standard is complied with the final value, observed or calculated, expressing the result of a test or analysis shall be rounded off in accordance with IS 2: 2022 'Rules for Rounding Off Numerical Values (*Second Revision*)'. The number of significant places retained in the rounded off value should be same as that of the specified value in this standard

## 1 SCOPE

This Indian standard specifies dimensional and other requirements for Ambu-Hesse's pattern valve used for preventing rebreathing during ventilation of lungs and for equipment for resuscitation

## 2 REFERENCES

The standard given below contain provisions which, through reference in this text, constitute provisions of this standard. At the time of publication, the editions indicated were valid. All standards are subject to revision, and parties to agreements based on this standard are encouraged to investigate the possibility of applying the most recent editions of these standards.

IS No.	Title
IS/ISO 5356-1 : 2015	Anaesthetic and Respiratory Equipment – Conical Connectors: Part 1 Cones and Sockets (First Revision)

## 3 MATERIALS

**3.1** The plastics parts shall be sturdy, non-breakable, clean, transparent and free from scratches. They shall be resistant to anaesthetic vapours and gases. They shall withstand the normal steam or chemical sterilization.

**3.2** The rubber parts shall be made of good quality natural, antistatic rubber. The rubber shall be resistant to anaesthetic vapours and gases. It shall withstand ageing in an air-oven for 168 hours at  $70 \pm 1^\circ\text{C}$  without showing appreciable stiffening, softening, cracking or other change in condition. It shall have a minimum tensile strength of  $10 \text{ MN/m}^2$  before and after ageing and a minimum elongation at break of 500 percent before ageing and 400 percent after ageing.

## 4 SHAPE AND DIMENSIONS

**4.1** The shape and dimensions shall be as shown in Fig. 1.

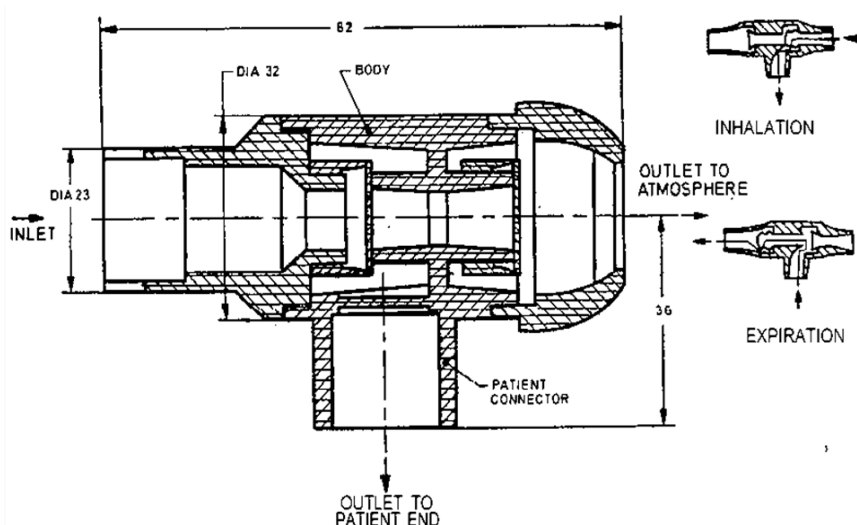

All dimensions in millimeters.

**FIG. 1 VALVE, AMBU-HESSE'S PATTERN**

**4.2** The dead space (space between the seat of the valve and the patient connector) shall not be more than 17 mm.

**4.3** A deviation of  $\pm 2.5$  percent shall be allowed on all dimensions.

## **5 WORKMANSHIP AND FINISH**

**5.1** The valve shall be designed to prevent rebreathing by ensuring unidirectional flow of all expired gases.

**5.2** The valve shall not stick at any stage.

**5.3** All the surfaces of the valve shall be smooth and free from pinholes, wrinkles, creases, embedded foreign matter and other defects.

**5.4** The inlet and outlet to patient end connections shall be suitable for conical fittings of adult and paediatric sizes conforming to IS/ISO 5356-1.

## **6 TESTS**

**6.1** The valve shall be tested for inspiration and expiration pressures. The resistance to flow at 25 l/min shall not be more than  $78 \text{ N/m}^2$  (approximately 0.8 cm of water) during inspiration and  $98 \text{ N/m}^2$  (approximately 1.0 cm of water) during expiration.

**6.2** The functioning of the valve shall remain unimpaired when the valve is operated at a frequency of 40 respirations per minute.

### **6.3 Non-return Action**

**6.3.1** The closing of the valve for inspiratory action shall not require a flow of air more than 35 l/min from the inlet side.

**6.3.2** The leakage through the valve, when the valve is closed in either direction under a gas pressure of  $1.96 \text{ kN/m}^2$  (approximately 20 cm of water), shall not be more than 400 ml/min.

## **7 MARKING AND PACKING**

**7.1** The valve shall be marked with the manufacturer's name, initials or recognized trademark; and an arrow mark on the body to indicate the direction of flow of gas.

**7.2** The packing shall be as agreed to between the purchaser and the manufacturer.

### **7.3 BIS Certification Marking**

The product(s) conforming to the requirements of this standard may be certified as per the conformity assessment schemes under the provisions of the *Bureau of Indian Standards Act, 2016* and the Rules and Regulations framed thereunder, and the product(s) may be marked with the Standard Mark.