

BUREAU OF INDIAN STANDARDS

DRAFT FOR COMMENTS ONLY

(Not to be reproduced without permission of BIS or used as an Indian Standard)

भारतीय मानक मसौदा
ओब्स्टेट्रिक्स उपकरण – संदंशिका, अंडाणु – आकार और परिमाण
(IS 6578 का दूसरा पुनरीक्षण)

Draft Indian Standard

Obstetrics Instruments – Forceps, Ovum – Shape and Dimensions
(Second Revision of IS 6578)

ICS 11.040.30

Obstetric and Gynaecological Instruments
and Appliances Sectional Committee, MHD 03

Last date for comments: **27 July 2024**

FOREWORD

(Formal clauses will be added later)

This standard was originally published in 1972. The first revision was published in 1992 to cover the requirements in respect of shape and dimensions only, as the specification part of these types of instruments is covered in IS 3642 (Part 1): 1990 Surgical instruments – Specification Part 1 Noncutting articulated instruments. This standard is, therefore, intended to be used only in respect of shape and dimensions which are referred to in 4.1 of IS 3642 (Part 1). The second revision of this standard has been brought out to align the standard with the latest style and format of Indian Standards.

For the purpose of deciding whether a particular requirement of this standard is complied with the final value, observed or calculated, expressing the result of a test or analysis shall be rounded off in accordance with IS 2: 2022 ‘Rules for Rounding Off Numerical Values (*second revision*)’. The number of significant places retained in the rounded off value should be same as that of the specified value in this standard.

1 SCOPE

This standard specifies the shape and dimensions for ovum forceps.

2 REFERENCES

The standards given below contain provisions which, through reference in this text, constitute provisions of this standard. At the time of publication, the editions indicated were valid. All standards are subject to revision, and parties to agreements based on this standard are encouraged to investigate the possibility of applying the most recent editions of these standards.

IS No.	Title
IS 3642 (Part 1) : 1990	Surgical instruments – Specification Part 1 Non-cutting, articulated instruments (<i>second revision</i>)

4 SHAPE AND DIMENSIONS

The shape and dimensions for the ovum forceps shall be as shown in Fig. 1.

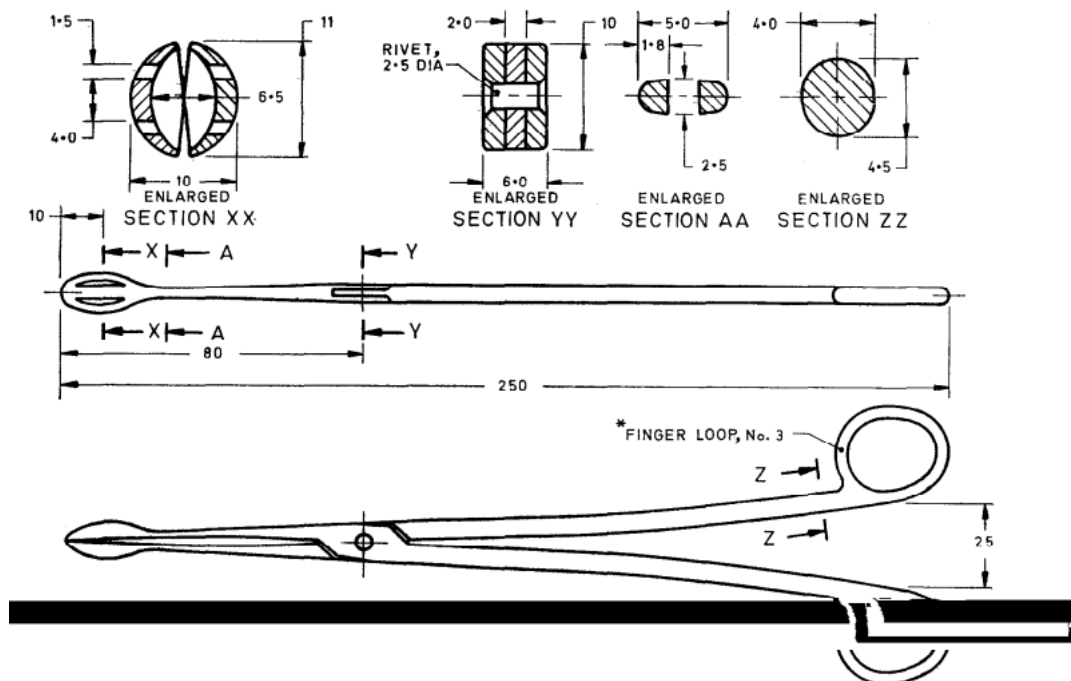

All dimensions in millimetres.

FIG. 1 FORCEPS, OVUM

3.2 Joints

The joint shall be box type in accordance with 13.2 of Section 3 of IS 3642 (Part 1).

3.3 Finger Loops

The finger loops shall conform to size No. 3 of Section 6 of IS 3642 (Part 1).

4 MARKING

4.1 The product shall be legibly and indelibly marked with the following:

- a) Manufacturer's name, initials or registered trade-mark;
- b) Country of manufacture; and
- c) The words 'Stainless Steel' or the letters 'SS'

4.2 BIS Certification Marking

The product(s) conforming to the requirements of this standard may be certified as per the conformity assessment schemes under the provisions of the *Bureau of Indian Standards Act, 2016* and the Rules and Regulations framed there under, and the product(s) may be marked with the Standard Mark.

5 PACKING

The forceps shall be wrapped in moisture-proof paper or packed in polyethylene bags avoiding contact with one another.