

BUREAU OF INDIAN STANDARDS

DRAFT FOR COMMENTS ONLY

(Not to be reproduced without permission of BIS or used as an Indian Standard)

भारतीय मानक मसौदा
विकर्षण प्रकार ग्रीवा कॉलर — विशिष्टि

(IS 12172 का पहला पुनरीक्षण)

Draft Indian Standard

Distraction Type Cervical Collar — Specification

(First Revision of IS 12172)

ICS 11.040.30

Orthopaedic Instruments, Implants and
Accessories Sectional Committee, MHD 02

Last date for comments: **xx January 2025**

FOREWORD

(Formal clauses will be added later)

This Indian Standard was first published in 1987. The first revision of this standard has been brought out to align the cross references to latest standards.

For the purpose of deciding whether a particular requirement of this standard is complied with, the final value, observed or calculated expressing the result of a test or analysis, shall be rounded off in accordance with IS 2: 2022 'Rules for rounding off numerical values (*second revision*)'.

1 SCOPE

This standard specifies requirements for distraction type cervical collar.

2 REFERENCES

The standards given below contain provisions which, through reference in this text, constitute provisions of this standard. At the time of publication, the editions indicated were valid. All standards are subject to revision, and parties to agreements based on this standard are encouraged to investigate the possibility of applying the most recent editions of these standards.

<i>IS No.</i>	<i>Title</i>
IS 7887 : 1992	Mild Steel Wire Rod for General Engineering Purposes — Specification (<i>first revision</i>)
IS 1741 : 2019	Latex Foam Rubber Products — Specification (<i>first revision</i>)
IS 3982 : 1997	Sheepskin Leather for Orthopaedic Linings — Specification (<i>first revision</i>)
IS 1720 : 1978	Specification for Cotton Sewing Threads (<i>first revision</i>)
IS 8156 : 2014	Fastners for Consumer Goods — Synthetic Hook and Loop Tape — Specification (<i>third revision</i>)
IS 6191 : 1971	Micro - Biological Colour Fastness and Microscopical Tests for Leather

3 SHAPE AND DIMENSIONS

The shape and dimensions of the collar shall be as per the requirement. However, a typical collar is shown in Fig. 1.

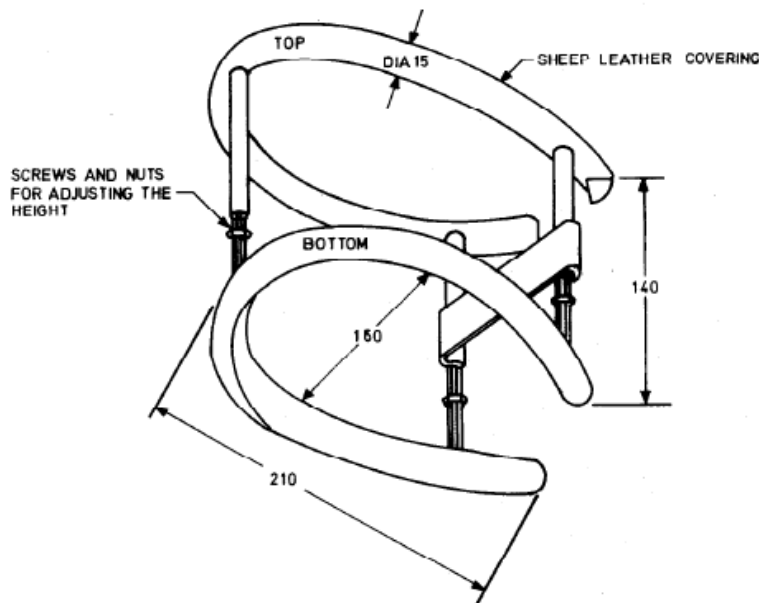

All dimensions in millimetres

FIG. 1 DISTRACTION CERVICAL COLLAR

4 MATERIAL

4.1 Frame

The frame of the collar shall be made of mild steel wire rod conforming to IS 7887.

4.2 Padding

Shall be made of latex rubber conforming to IS 1741.

4.3 Leather

The leather covering used shall conform to IS 3982.

4.4 Sewing Thread

Cotton sewing thread of 60s/6 (100 dtex x 6) conforming to Variety No. 31 of IS 1720.

4.5 Fasteners

Ends of the collar shall have fasteners conforming to IS 8156. The tape shall have the minimum width of 2.5 cm and overlap of 2.5 cm.

5 REQUIREMENTS

5.1 Distraction cervical collar shall be tailored neatly.

5.2 The frame of the collar shall be made of mild steel and the metallic frame shall be padded with latex foam rubber and covered with sheepskin leather.

5.3 The leather used for covering shall be reasonably strong, possess smooth surface to avoid chaffing of the skin when in contact, durable and sweat resistant. Besides, it shall be sufficiently flexible so that the lining can readily take to the shape and form of the collar.

5.4 The leather shall be dye finished, preferably and the dyes employed shall have good fastness to sweat. In case, the leather is to be pigment finished, the pigments used shall be non-irritant.

5.5 Sweat Contrast Grading

Colour fastness after 1024 revolutions for dry rubbing shall be 5 and for wet rubbing 4, when tested according to LF 9 of IS 6191.

5.6 The collar shall be provided with screws and nuts (as shown in Fig. 1) for adjusting the height as per requirement.

5.7 The collar, when worn, shall not give any uncomfortable feeling.

6 MARKING

The collar shall be marked with the manufacturer's name, initials or recognized trademark.

6.1 BIS Certification Marking

The product(s) conforming to the requirements of this standard may be certified as per the conformity assessment schemes under the provisions of the *Bureau of Indian Standards Act, 2016* and the Rules and Regulations framed thereunder, and the product(s) may be marked with the Standard Mark.

7 PACKAGING

As agreed to between the purchaser and the supplier.