

BUREAU OF INDIAN STANDARDS

DRAFT FOR COMMENTS ONLY

(Not to be reproduced without permission of BIS or used as an Indian Standard)

भारतीय मानक मसौदा
आर्थोपेडिक स्टेपल पंच — विशिष्टि
(IS 7107 का पहला पुनरीक्षण)

Draft Indian Standard

Orthopaedic Staple Punch — Specification

(First Revision of IS 7107)

ICS 11.040.30

Orthopaedic Instruments, Implants and Accessories Sectional Committee, MHD 02 Last date for comments: **27 November 2024**

FOREWORD

(Formal clauses will be added later)

This standard was first published in 1973. The first revision of this standard has been brought out to align the cross references to latest standards.

For the purpose of deciding whether a particular requirement of this standard is complied with, the final value, observed or calculated expressing the result of a test or analysis, shall be rounded off in accordance with IS 2 : 2022 'Rules for rounding off numerical values (*second revision*)'

1 SCOPE

This standard specifies dimensions and other requirements for staple punch used for punching the staples in the bone.

2 REFERENCES

The standards given below contain provisions which, through reference in this text, constitute provisions of this standard. At the time of publication, the editions indicated were valid. All standards are subject to revision, and parties to agreements based on this standard are encouraged to investigate the possibility of applying the most recent editions of these standards.

<i>IS No.</i>	<i>Title</i>
IS 1070: 2023	Reagent Grade Water — Specification (<i>fourth revision</i>)
IS 6603: 2024	Stainless Steel Semi-Finished Products, Bars, Wire Rods and Bright Bars — Specification (<i>second revision</i>)

3 MATERIAL

Stainless Steel bars conforming to Designation 20Cr13 or 30Cr13 of IS 6603.

4 SHAPE AND DIMENSIONS

As shown in Fig. 1

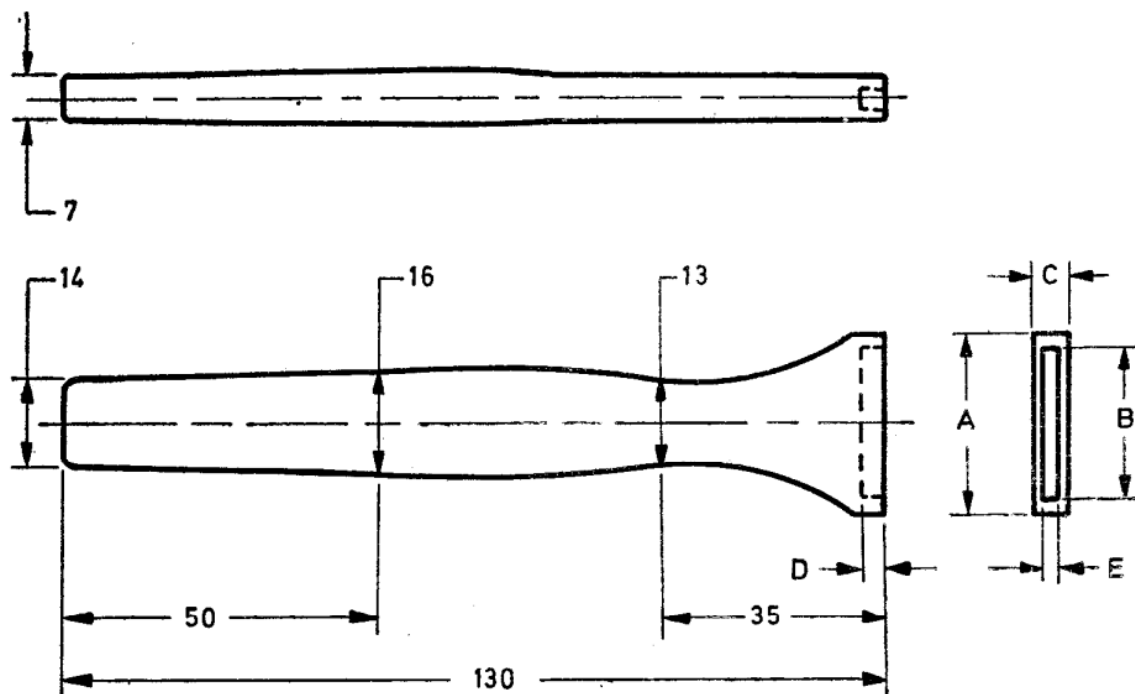

(1) Size	(2) A	(3) B	(4) C	(5) D	(6) E
Large	28	23.5	5.0	4.0	3.7
Small	21	18.0	4.5	3.5	2.7

All dimensions in millimetres.

FIG. 1 PUNCH, STAPLE, ORTHOPAEDIC

5. HEAT TREATMENT

The punch shall be hardened and tempered to 400 to 500 *HV*.

6. WORKMANSHIP AND FINISH

6.1 The punching end shall have groove to accommodate the staple as shown in Fig. 1.

6.2 It shall be free from pits, burrs, draw-marks, cracks and other surface contaminations.

6.3 It shall be passivated and polished bright.

7. CORROSION RESISTANCE

7.1 Test-Scrub the instrument with soap and warm water, rinse in hot water and then dip in 95 percent ethyl alcohol. Dry the instrument, immerse in copper Sulphate solution at room temperature for 6 minutes and wash with fresh water or wet cotton wool.

7.2 The copper sulphate solution shall be made up as follows:

Copper sulphate ($\text{CuSO}_4 \cdot 5\text{H}_2\text{O}$)	4.0 g
Sulphuric acid (H_2SO_4) (Sp gr 1.84)	10.0 g
Distilled water (<i>see</i> IS 1070)	90.0 ml

7.3 There shall be no red stains or spots on the instrument, but dulling of the polished surface may be permitted.

8 MARKING

Shall be marked with the manufacturer's name or recognized trade-mark.

8.1 BIS Certification Marking

The product(s) conforming to the requirements of this standard may be certified as per the conformity assessment schemes under the provisions of the *Bureau of Indian Standards Act, 2016* and the Rules and Regulations framed thereunder, and the product(s) may be marked with the Standard Mark.

9 PACKING

As agreed to between the purchaser and the supplier.