

**BUREAU OF INDIAN STANDARDS**

**DRAFT FOR COMMENTS ONLY**

*(Not to be reproduced without the permission of BIS or used as an Indian Standard)*

**भारतीय मानक मसौदा**

**घरेलू सिलाई मशीनें — हस्त संयोजन समुच्चय**

**( आई एस 13192 का पहला पुनरीक्षण )**

**DRAFT Indian Standard**

**Household Sewing Machines — Hand Attachment Assembly**

**( First Revision of IS 13192 )**

ICS 61.080

---

Sewing Machines Sectional  
Committee, MED 29

Last date for receipt of comments  
is **XX XX XXXX**

---

**FOREWORD**

*(Formal clause will be added later on)*

This standard was originally issued in 1991. In this revision, the following major changes have been made:

- a) A reference clause has been added mentioning the latest version of the referred standards;  
and
- b) A clause **9.2** regarding BIS certification marking has been added.

This standard has been prepared to unify and rationalize the types and sizes of hand attachment to be used to ensure correct assembly and fitting to the sewing machine.

For the purpose of deciding whether a particular requirement of this standard is complied with, the final value, observed or calculated, expressing the result of a test or analysis shall be rounded off in accordance with IS 2 : 2022 'Rules for rounding off numerical values (*second revision*)'. The number of significant places retained in the rounded off value should be the same as that of the specified value in this standard.

## **DRAFT Indian Standard**

### **HOUSEHOLD SEWING MACHINES — HAND ATTACHMENT ASSEMBLY**

( *First Revision* )

#### **1 SCOPE**

**1.1** This standard lays down the requirements for hand attachment assembly for sewing machines for household purposes.

**1.2** It deals with hand attachment assembly to be used with spoked-type flywheels only.

#### **2 REFERENCE**

The Indian Standard listed in below contain provisions which, through reference in this text, constitute provision of this standard. At the time of publication, the editions indicated were valid. All standards are subject to revision, and parties to agreements based on this standard are encouraged to investigate the possibility of applying the most recent editions of the standards listed below:

<i>IS/ISO No.</i>	<i>Title</i>
IS 1068 : 1993	Electroplated coatings of nickel plus chromium and copper plus nickel plus chromium — Specification ( <i>third revision</i> )
IS 2500 (Part 1) : 2000 ISO 2859-1 : 1999	Sampling procedures for inspection by attributes: Part 1 Sampling schemes indexed by acceptance quality limit (AQL) for lot-by-lot inspection ( <i>third revision</i> )
IS 4905 : 2015 ISO 24153 : 2009	Random sampling and randomization procedures ( <i>first revision</i> )

#### **3 NOMENCLATURE**

**3.1** The nomenclature for hand attachment assembly is shown in Fig. 1.

**3.2** The details of various parts used in the assembly are given in Table 1.

#### **4 MATERIAL**

All the parts of hand attachment assembly shall be manufactured from suitable materials to achieve the required function/performance.

#### **5 HARDNESS**

The bearing surfaces of parts and springs shall be hardened to achieve the desired properties/performances or as per the agreement of the supplier and purchaser.

#### **6 DIMENSIONS**

The main dimensions for hand attachment assembly shall be as shown in Fig. 2.

## **7 TOLERANCES**

**7.1** The error in parallelism between the plane of movement of driving lever catch and the contact face of bracket with the sewing machine shall not exceed 0.05 mm per 100 mm.

**7.2** The error in parallelism between the axis of holes for large and small gear shall not exceed 0.25 mm.

**7.3** The axial play on either large gear or driving lever shall be kept minimum.

**7.4** The side play on the large gear and driving lever catch at any position of the handle shall be kept minimum.

**7.5** The backlash between the teeth of gears shall be minimum in any position of the handle.

**7.6** The noise level shall be low when run at a speed of 1 000 rev/min of driving lever. This shall be compared with the approved sample accepted by the supplier and the purchaser for this purpose.

## **8 WORKMANSHIP AND FINISH**

**8.1** The surface finish of all the externally visible parts shall be good and smooth.

**8.2** All external edges of the hand attachment assembly shall be rounded off to a smooth finish.

**8.3** Nickel and chromium plating on the parts of hand attachment assembly shall generally conform to IS 1068 and shall be compared with approved samples to be supplied for the purpose.

**8.4** The painting/finishing shall be good as per the approved sample supplied for the purpose. The colour shall be as agreed between the supplier and the purchaser.

**8.4.1** The transfer of good quality may be fixed symmetrically on the body of hand attachment as per agreement between the purchaser and the supplier.

**8.5** The gear teeth shall be free from paint, burrs and any abrasive particles.

**8.6** The fixation of cover on the body of hand attachment shall be rigid.

**8.7** The fixation of large gear assembly and driving lever assembly on the body of hand attachment shall be very firm and the torque required to open shall be 1.4 Nm.

**8.8** The fixation of spring on driving lever shall be rigid.

**8.9** Gear piston shall neither be very tight, nor very loose as to allow the handle driver to get disengaged during motion at the specified speed.

**8.10** The movement of driving lever catch from engaged to disengaged position and vice versa shall be smooth.

**8.11** The handle shall rotate freely on its screw and the axial play on the screw shall be negligible.

## 9 MARKING

**9.1** The handle attachment assembly may be marked with the manufacturer's name or trade-mark.

### 9.2 BIS Certification Marking

The product(s) conforming to the requirements of this standard may be certified as per the conformity assessment schemes under the provisions of the *Bureau of Indian Standards Act, 2016* and the Rules and Regulations framed thereunder, and the products may be marked with the Standard Mark.

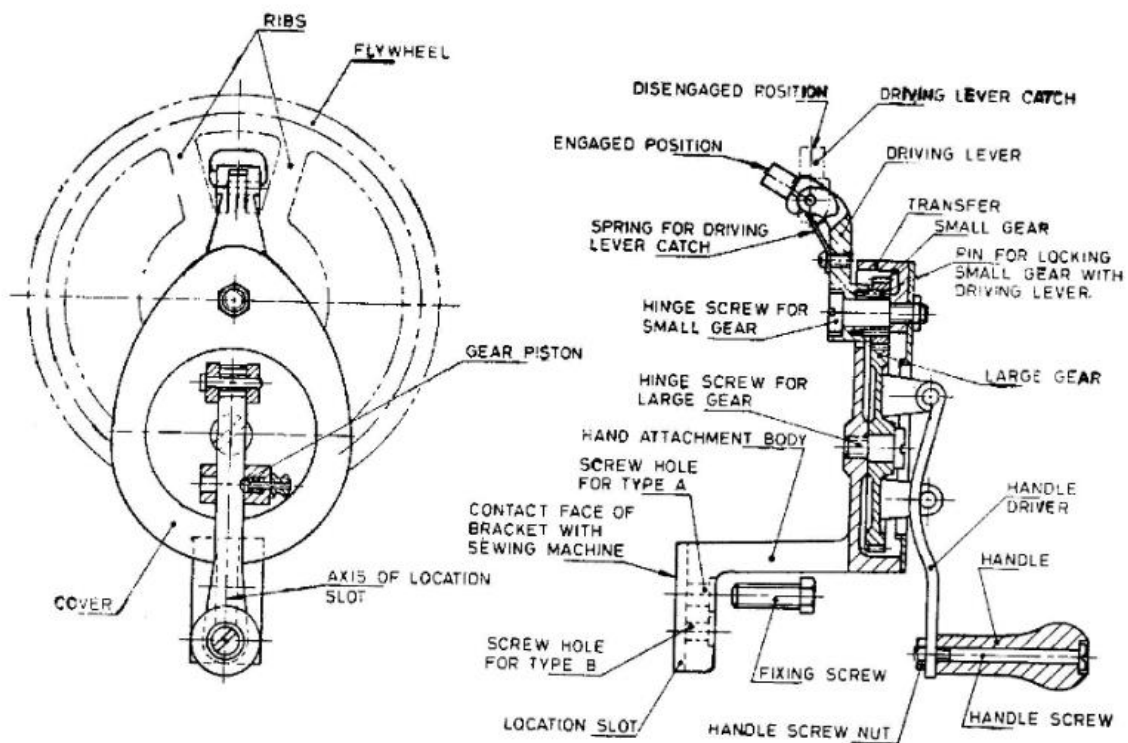

FIG. 1 TERMINOLOGY FOR HAND ATTACHMENT ASSEMBLY

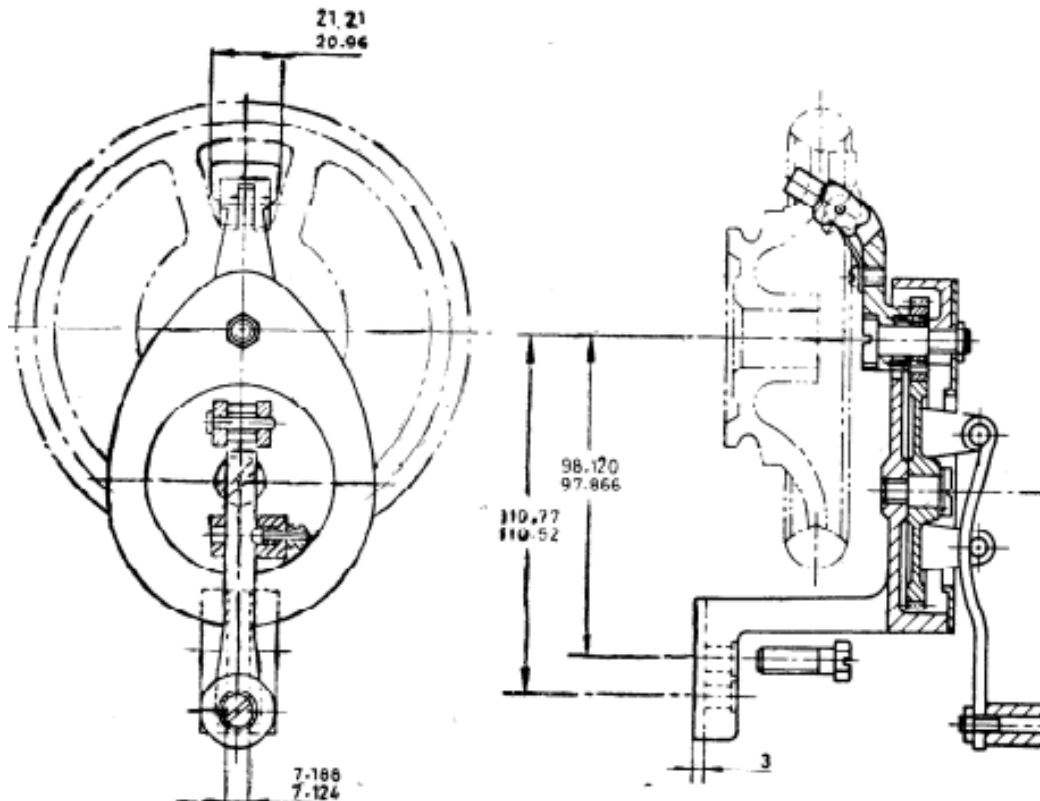

FIG. 2 DIMENSION FOR HAND ATTACHMENT ASSEMBLY

## 10 PACKING

**10.1** The wearing out surfaces shall be well lubricated with good quality lubricating oil.

**10.2** Each hand attachment assembly shall be individually wrapped in a polyethylene bag after giving a rust preventive coating on all the parts.

**10.3** The wrapped hand attachments shall be packed in a card board carton/wooden box as per the best prevailing practice in the trade. The number of hand attachments to be packed in carton/case shall be as agreed between the supplier and the purchaser.

**10.3.1** The manufacturer's name, trade-mark, quantity of contents and colour shall be marked on the carton/packing box.

**10.4** One fixing screw shall be supplied with each hand attachment assembly.

## 11 SAMPLING

Unless otherwise agreed between the suppliers and the purchasers the sampling plan in Annex A shall be followed. For further information, reference may be made to IS 2500 (Part 1).

## **12 TESTS**

**12.1** When rotated at a very slow speed during one complete rotation, the motion shall be uniform, smooth, and light without any sticky feeling.

**12.2** After fixing the hand attachment assembly on sewing machine and engaging the catch with any gap between the ribs on a flywheel, the catch shall not get disengaged even when the hand attachment is rotated at a speed of 1 000 rev/min (at flywheel) and/or is rotated intermittently by jerks.

**ANNEX A**  
(*Clause 11*)

**SCALE OF SAMPLING AND CRITERIA FOR CONFORMITY**

**A-1 SCALE OF SAMPLING**

**A-1.1 Lot**

In any consignment, all the hand attachment assemblies of the same type and manufactured from the same material under essentially similar conditions of manufacture shall be grouped together to constitute a lot.

**A-1.2** For ascertaining the conformity of the lot to the requirements of the specification, tests shall be carried out for each lot separately. The number of hand attachment assemblies to be selected at random for this purpose shall be in accordance with column 2 and column 3 of Table 1.

**A-1.3** If the oscillating rock shafts are packed individually in order to ensure the randomness of selection, IS 4905 shall be used.

**A-1.4** If the hand attachment assemblies are packed in different cartons, a suitable number of cartons (not less than 20 percent of the total in the lot subject to a minimum of 2) shall be chosen, at random. From each of the cartons so chosen an approximately equal number of hand attachment assemblies shall be picked up from its different parts so as to obtain the required number of hand attachment assemblies specified in column 3 of Table 1.

**A-2 NUMBER OF TESTS AND CRITERIA FOR CONFORMITY**

**A-2.1** The hand attachment assemblies selected according to **A-1.2** and **A-1.3** or **A-1.4** shall be examined for dimensions (*see 6*), tolerances (*see 7*) and workmanship and finish (*see 8*). If the number of oscillating rock shaft failing to meet one or more of the requirements mentioned above is less than or equal to the permissible number of defectives given in column 4 of the Table 1, the lot shall be declared as conforming to the requirements of these characteristics.

**A-2.2** In case of those lots which have been found satisfactory according to **A-2.1**, a number of hand attachment assemblies equal to the sample size indicated in column 5 of Table 1, shall be subjected to hardness test (*see 5*). Any oscillating rock shaft failing to meet the requirement for hardness shall be considered to be defective.

**A-2.2.1** If no defectives are found among the hand attachment assemblies subjected to the hardness test (*see A-2.2*), the lot shall be declared as conforming to the requirements of the specification, otherwise not.

**Table 1 Scale of Sampling and Permissible Number of Defectives**

(Clauses A-1.2, A-1.4, A-2.1 and A-2.2)

SI No.	No. of hand attachment assemblies in the Lot $N$	For Dimensions, Tolerances and Workmanship and Finish		Sample Size for Hardness and Tests
		Sample Size $n$	Permissible No. of Defectives <sup>1</sup>	
(1)	(2)	(3)	(4)	(5)
i)	Up to 15	5	0	2
ii)	16 to 40	8	0	3
iii)	41 to 110	13	0	3
iv)	111 to 300	20	1	5
v)	301 to 500	32	1	6
vi)	501 to 800	50	2	8
vii)	801 to 1 300	80	3	10
viii)	1 301 and above	125	5	15

1) This ensures that lots containing one and half percent or less defective will be accepted most of the time