

**BUREAU OF INDIAN STANDARDS**

**DRAFT FOR COMMENTS ONLY**

*(Not to be reproduced without the permission of BIS or used as an Indian Standard)*

*भारतीय मानक मसौदा*

**औद्योगिक उपयोग हेतु लाइट ड्यूटी सिलाई मशीन शीर्षों के  
लिए सामान्य अपेक्षाएं**

*( आईएस 12109 का पहला पुनरीक्षण )*

**DRAFT Indian Standard**

**General Requirements for Light Duty Sewing  
Machine Heads for Industrial Use**

*( First Revision of IS 12109 )*

ICS 61.080

---

Sewing Machine Sectional  
Committee, MED 29

Last date for receipt of comments  
is **06 January 2025**

---

**FOREWORD**

*(Formal clause will be added later)*

This standard was originally issued in 1987. This standard is being revised again to keep pace with the latest technological developments and international practices. Also, in this revision, the standard has been brought into the latest style and format of Indian Standards, and references of Indian Standards, wherever applicable have been updated. BIS certification marking clause has been modified to align with the revised *Bureau of Indian Standards Act, 2016*. In this revision all the amendments have been incorporated. The following major modifications have been incorporated in this revision of the standard:

- a) A reference clause has been added mentioning the latest version of the referred standards;  
and
- b) The international classification for standards (ICS) number has been added;

For the purpose of deciding whether a particular requirement of this standard is complied with, the final value, observed or calculated, expressing the result of a test or analysis, shall be rounded off in accordance with IS 2 : 2022 'Rules for rounding off numerical values (*second revision*)'. The number of significant places retained in the rounded off value should be the same as that of the specified value in this standard.

**DRAFT Indian Standard**

**GENERAL REQUIREMENTS FOR LIGHT DUTY SEWING  
MACHINE HEADS FOR INDUSTRIAL USE**

( *First Revision* )

## 1 SCOPE

This standard covers the general requirements of L 12<sup>1</sup> type light duty industrial sewing machine heads with maximum speed of 1 800 stitches per minute and mainly used for light fabric stitching. The main feature being rotary hook for lower thread which operates. In a full rotary motion in a vertical plane on a horizontal axis, link-type, thread take-up and positive transmission from arm shaft to rotary hook shaft.

<sup>1)</sup> L 12 stand for lock-stitch, single needle, two threads (*see* IS 9152).

## 2 REFERENCES

The standards given below contain provisions which, through reference in this text, constitute provision of this standard. At the time of publication, the editions indicated were valid. All standards are subject to revision, and parties to agreements based on this standard are encouraged to investigate the possibility of applying the most recent edition of these standards:

<i>IS No.</i>	<i>Title</i>
IS 210 : 2009	Grey iron castings — Specification ( <i>fifth revision</i> )
IS 2500 (Part 1) : 2000/ ISO 2859-1 : 1999	Sampling procedure for inspection by attributes: Part 1 Sampling schemes indexed by acceptance quality limit (AQL) for lot-by-lot inspection ( <i>third revision</i> )
IS 9152 : 2023	Industrial sewing machines — Glossary of terms and identification symbols ( <i>first revision</i> )

## 3 CONSTRUCTION AND FUNCTION

**3.1** Arm and bed shall be manufactured from grey cast iron castings conforming to grade FG 150 of IS 210.

**3.2** The components used in the sewing machine head shall be of such materials, and dimensions and precision that the assembly clearances before and after continuous running on no load shall conform to the values given in Table 1.

**3.3** The needle plate and slide plate shall be properly fitted on machine bed to permit smooth feeding of fabric.

**3.4** Needle location shall be approximately in the centre of hole to allow its free movement.

**3.5** The feed dog shall be capable of being raised up to a height of 1.2 mm above the surface of needle plate without interference.

**3.6** In the raised position of presser foot, the minimum clearance between the presser foot and needle plate surface shall be 6 mm. There shall be provision to raise the presser foot with the help of knee lifter attachment.

**3.7** All the components shall be securely fitted and shall permit smooth movement.

#### **4 FINISH**

**4.1** The sewing machine body shall be painted on all external surfaces to give smooth and even appearance. The transfers applied shall be firm and without unusual printing defects.

**4.2** The components shall be coated with paint or given a suitable surface treatment to prevent rust. The slide plate, needle plate and balance wheel shall have a minimum plating thickness of 15 micrometres. The plated surfaces shall be smooth, and free from plating defects.

#### **5 SEWING MECHANISM**

##### **5.1 Reverse Stitching**

Sewing machine shall be provided with means to reverse the feeding action of the feed dog for back-tack stitching which shall be capable of being performed while the machine is in operation.

##### **5.2 Stitch Regulator**

The stitch regulator shall be provided in the machine at convenient location and shall be capable of adjusting the length of stitch over a range of 7 stitches to 20 stitches per 25 mm. Suitable indication shall be provided for increase/decrease in stitch length.

##### **5.3 Balance Wheel**

The machine shall be provided with a balance wheel which shall have a belt groove to transmit drive from treadle mechanism or electric motor to the sewing machine. There shall be suitable provision to disengage the drive from the sewing mechanism, whenever required.

##### **5.4 Thread Tension**

The machine shall be provided with thread tension arrangement to adjust the amount of tension required to sew satisfactory stitches and means shall be provided for automatic thread tension release when presser foot is raised to the maximum height.

#### **6 LUBRICATION**

Means shall be provided to apply lubricant readily and properly to all bearings and rubbing surfaces in the machine.

## **7 ACCURACY REQUIREMENTS**

**7.1** The sewing machine shall have smooth movement without any abnormal sound.

**7.2** The accuracy of all moving parts shall be such as to ensure smooth functioning of the sewing machine. The assembly clearances shall conform to the values given in Table 1.

## **8 DURABILITY REQUIREMENTS**

To check the performance of sewing machine and the components used, the machine shall be operated continuously for 4 h at 1 800 rev/min at no load using maximum forward feed. Lubricate the machine before the test and at half an hour intervals. The difference in assembly clearances before and after the test shall not exceed the values given in Table 1.

**Table 1 Assembly Clearances and Maximum Allowable Change After Durability Test**

*(Clauses 3.2, 7.2 and 8)*

Sl No.	Item	Measuring Condition	Measuring Direction	Indicator Position	Approx Pressure, g	Ref to Fig.	Maximum Assembly Clearance	Maximum Change in Assembly Clearance After Durability Test
(1)	(2)	(3)	(4)	(5)	(6)	(7)	(8)	(9)
1)	Needle bar	Needle bar at lowermost position	a) in the direction of motion	Top face of link stud	500	1	0.10	0.04
			b) At right angle to the direction of motion	On needle clamp	500 <sup>1</sup>	1	0.10	0.03
ii)	Thread take up lever	Thread take up lever at top and intermediate position of motion	a) in the direction of motion	Around the thread hole	100	2A	0.50	0.10
			b) At right angle to the direction of motion		100	2B	0.75	0.20
iii)	Rotation hook	With bobbin-case removed play of bobbin case holder	a) In and out	On the centre pin	100	3	0.07	0.02
			b) Up and down	Top of the holder	100	3	0.16	0.03
iv)	Feed mechanism	Feed dog at the highest position above the needle plate	In the direction of motion	On the front teeth	500	4	0.35	0.15
v)	Arm shaft	Shaft end	Axial	On the flywheel	1 000	–	0.05	0.02
vi)	Rotating hook shaft	Shaft end	Axial	Shaft end	500	–	0.04	0.02

1) Pressure to be applied just below the lower needle bar bushing.

## 9 SEWING REQUIREMENTS

The sewing test shall be carried out as per conditions stipulated in Table 2 and shall satisfy the following requirements.

- 9.1 There shall be no skip stitching.
- 9.2 There shall be no unusual thread breakage.
- 9.3 Stitches shall have uniform length and thread tension shall be proper.
- 9.4 There shall be no noticeable fabric puckering.
- 9.5 Feed mechanism function shall be proper.

**Table 2 Sewing Requirements**

(Clause 9)

Sl No.	Item	Needle	Type of Thread	Fabric	No. of Layers	Stitch Length (Approx) mm	Sewing Speed (Approx) rev/min	Sewing Length (Approx) mm
(1)	(2)	(3)	(4)	(5)	(6)	(7)	(8)	(9)
i)	Regular sewing	14	Cotton thread	Shirting cloth	2	1.5 and 3	1 000 and 1 800	1 000
ii)	Stem sewing	14	Cotton	Muslin (length of step approx 25 mm)	4 to 12 and 12 to 4	do	1 000	300
iii)	Heavy material	16	Cotton thread	Drill cloth	2	3	1 000	1 000
iv)	Light material	11	Silk thread	Rain synthetic fabric	2	1.5	1 800	1 000
v)	Sewing test for straightness	14	—	Blue print paper	2	3	1 500	300 with hands free. The <i>Max</i> height of are shall be below 5 for the free chord of 200

## 10 ACCESSORIES

The accessories like spool pins, bobbins, needles, screw drivers, oil can, etc, shall be placed in a suitable metal or plastic box and the quantity of such accessories may be decided by the manufacturers as per customer's requirements.

## 11 MARKING

11.1 Each machine shall be identified by a name plate giving the type, serial no. and the

manufacturer's name or trade-mark; the serial no. may be given on bed plate, if not given on nameplate.

### **11.2 BIS Certification Marking**

The product(s) conforming to the requirements of this standard may be certified as per the conformity assessment schemes under the provisions of the *Bureau of Indian Standards Act, 2016* and the Rules and Regulations framed thereunder, and the products may be marked with the Standard Mark.

### **12 PACKING**

All parts of the machine which are free to move or rotate shall be packed in strong wooden packing cases or corrugated cardboard boxes, securely fastened in a fixed position to prevent movement or vibration while in transit. The tools and accessories box shall be placed in the packing case in such a way that it does not directly come in contact with the machine. The box shall be securely fastened in a closed position to prevent opening in transit.

### **13 SAMPLING**

Unless otherwise agreed to between the supplier and the purchaser, the single sampling plan with inspection level II and AQL of 2.5 percent as given in Table 1 and Table 2 of IS 2500 (Part 1)/ISO 2859-1, shall be followed.

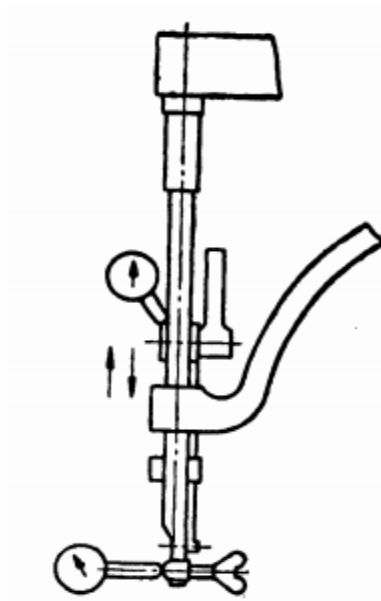

**FIG. 1 NEEDLE BAR**



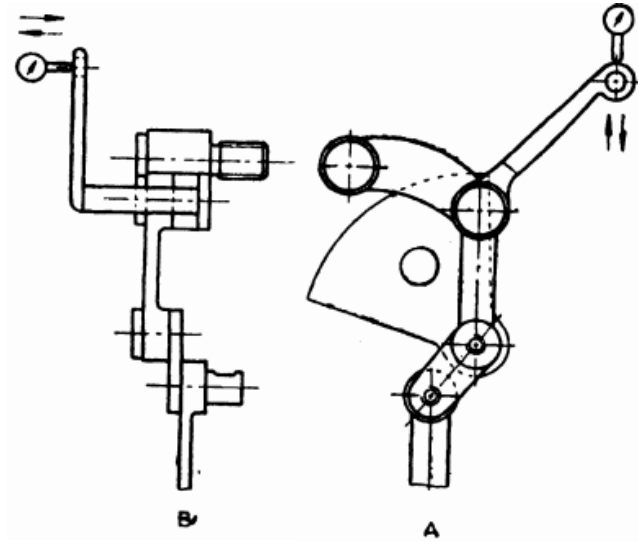

FIG. 2 THREAD TAKE UP LEVER

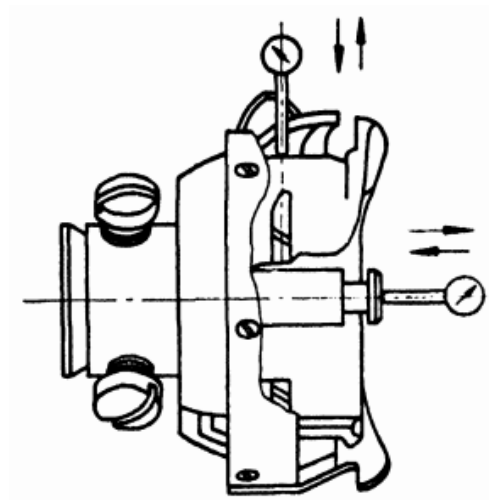

FIG. 3 ROTATION HOOK

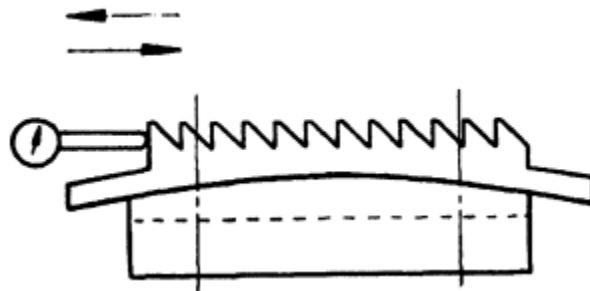

FIG. 4 FEED MECHANISM