

**BUREAU OF INDIAN STANDARDS**

**DRAFT FOR COMMENTS ONLY**

*(Not to be reproduced without the permission of BIS or used as an Indian Standard)*

**भारतीय मानक मसौदा**

**औद्योगिक सिलाई मशीनें (लाइट ड्यूटी) — स्टैंड — विशिष्टि**

*( आई एस 14477 का पहला पुनरीक्षण )*

**Draft Indian Standard**

**INDUSTRIAL SEWING MACHINES (LIGHT DUTY) — STAND  
— SPECIFICATION**

*( First Revision of IS 14477 )*

ICS 61.080

---

Sewing Machine Sectional  
Committee, MED 29

Last date for receipt of  
comments is **20 January 2024**

---

**FOREWORD**

*(Formal clause to be added later)*

This standard was first published in 1997. The present revision has been taken up with a view to incorporating the modifications found necessary as a result of experience gained on the use of this standard. Also, in this revision, the standard has been brought into the latest style and format of Indian Standard, and references to Indian Standards, wherever applicable have been updated. The BIS certification marking clause has been modified to align with the revised *Bureau of Indian Standards Act, 2016*

For the purpose of deciding whether a particular requirement of this standard is complied with, the final value, observed or calculated, expressing the result of test or analysis, shall be rounded off in accordance with IS 2 : 2022 'Rules for rounding off numerical values (*second revision*)'. The number of significant places retained in the rounded-off value should be the same as that of the specified places retained in the rounded-off value should be the same as that of the specified value in this standard.

## **1 SCOPE**

This standard lays down the requirements for treadle/electric motor driven stand used with wooden table for light-duty sewing machines for industrial use.

## **2 REFERENCES**

The standards listed below contain provisions which, through their references in the text, constitute the provision of this standard. At the time of publication, editions indicated were valid. All standards are subject to revision and parties to the agreement based on this standard are encouraged to investigate the possibility of applying the most recent editions of the standards indicated below:

<i>IS No.</i>	<i>Title</i>
IS 210 : 2009	Grey iron castings - Specification ( <i>fifth revision</i> )
IS 1570 (Part 2/ Sec 1) : 1979	Schedules for wrought steels : Part 2 Carbon Steel (unalloyed steel), Section 1 Wrought products (other than wire) with specified chemical composition and related properties ( <i>first revision</i> )

## **3 NOMENCLATURE**

The nomenclature for the stand shall be as indicated in Fig. 1.

## **4 MATERIAL**

**4.1** Cast iron parts shall be manufactured from cast iron corresponding to Grade FG 150 of IS 210.

**4.2** Steel parts shall be manufactured from any suitable steel, such as Designation 20C8 or 40C8 of IS 1570 (Part 2/Sec 1).

## **5 HARDNESS**

Steel parts manufactured for 40C8 or 20C8 steel shall have a minimum hardness of 400HV. Bearing surface of band wheel crank and hinge pins of treadle shall have a minimum hardness of 400 HV.

## **6 DIMENSION**

Dimensions of main parts shall conform to the following:

i)	Height of leg (including rollers)	720 mm, <i>Min</i>
ii)	Height of leg (without rollers)	720 mm, <i>Min</i>
iii)	Width of centre brace	625 mm, <i>Min</i>
iv)	Diameter of band wheel (bottom of belt groove)	440 mm, <i>Min</i>
v)	Size of treadle	330 mm × 250 mm

## **7 WORKMANSHIP AND FINISH**

**7.1** Wheel groove and wheel rim shall have a smooth finish.

**7.2** Parts shall be assembled firmly and shall function satisfactorily.

**7.3** Band wheel crank shall function smoothly with minimum play.

**7.4** Treadle shall function smoothly with minimum play.

**7.5** All the hinge and bearing parts shall be properly lubricated.

**7.6** Right hand leg shall be fitted with rollers and the rollers shall turn smoothly. Left hand leg shall be without rollers. The two rollers and two legs shall sit firmly on the floor. Suitable vibration dampers may be provided for damping the vibrations transmitted to the operator.

**7.7** Treadle shall have provision for spring loaded rod for starting, speed variation and stopping the electric motor (fitted on the underside of wooden table) with clutch unit. The electric motor shall be properly earthed and insulated.

**7.8** All parts shall be sufficiently strong and rigid.

**7.9** Castings shall be free from detrimental defects such as sand drops, blow holes, cracks, fins, burrs, etc. Casting shall be painted with staving paint and shall be even baked. The paint coating shall be smooth and free from run, dust, mars, peelings, etc.

**7.10** Steel parts shall be given antirust surface finish treatment.

## **8 MARKING**

**8.1** Each piece of the stand shall be legibly and indelibly marked with the source of manufacture and trade mark, if any.

### **8.2 BIS Certification Marking**

The product may also be marked with the Standard Mark.

**8.2.1** The product(s) conforming to the requirements of this standard may be certified as per the conformity assessment schemes under the provisions of the *Bureau of Indian Standards Act, 2016* and the Rules and Regulations framed thereunder, and the products may be marked with the Standard Mark.

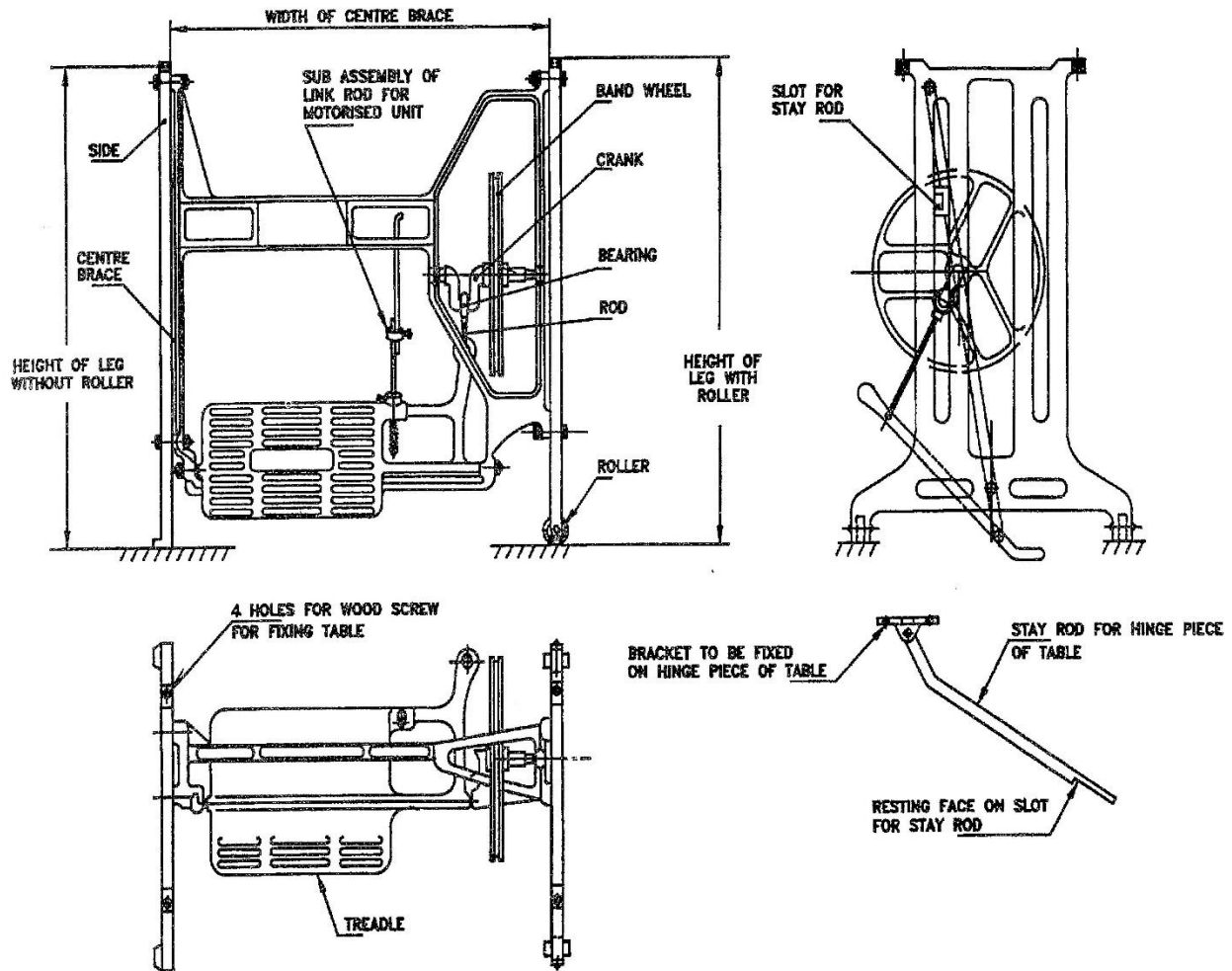

FIG. 1 NOMENCLATURE OF INDUSTRIAL SEWING MACHINE — STAND

## 9 PACKING

9.1 Each item of the painted cast iron component shall be wrapped separately in a polyethylene bag after proper cleaning and removing dust, etc. in such a manner that no dust can enter it.

9.2 All the hardware items, pitman bearing, etc. shall be packed in a polyethylene bag.

9.3 Wrapped items of the stand shall be packed in a strong wooden/corrugated paper packing box along with a spanner, as per best prevailing practice in the trade. The number of stand sets to be packed in a packing box shall be as agreed to between the supplier and the purchaser.