

BUREAU OF INDIAN STANDARDS

DRAFT FOR COMMENTS ONLY

(Not to be reproduced without the permission of BIS or used as an Indian Standard)

भारतीय मानक मसौदा

घरेलू प्रयोजन की सिलाई मशीनों के लिए फ़ीड लिफ्टिंग रॉक

शाफ्ट क्रैंक — विशिष्टि

(आई एस 10306 का पहला पुनरीक्षण)

DRAFT Indian Standard

**FEED LIFTING ROCK SHAFT CRANK FOR SEWING
MACHINES FOR HOUSEHOLD PURPOSES — SPECIFICATION**

(First Revision of IS 10306)

ICS 61.080

**Sewing Machines
Sectional Committee, MED 29**

**Last date for receipt of
comments is 30 May 2022**

FOREWORD

(Adoption clauses to be added later)

This standard was first published in 1982.

Major changes in this revision are as follows:

- a) The dimension of the small hole diameter has been revised;
- b) The dimension of the feed lifting rock shaft cranks has been modified; and
- c) Tolerances have been revised.

For the purpose of deciding whether a particular requirement of this standard is complied with, the final value, observed or calculated, expressing the result of a test or analysis shall be rounded off in accordance with IS 2:2022 'Rules for rounding off numerical values (*second revision*)'. The number of significant places retained in the rounded off value should be the same as that of the specified value in this standard.

DRAFT Indian Standard

**FEED LIFTING ROCK SHAFT CRANK FOR SEWING
MACHINES FOR HOUSEHOLD PURPOSES — SPECIFICATION**

(*First Revision*)

1 SCOPE

This standard covers the requirements for feed lifting rock shaft cranks for sewing machines for household purposes.

2 REFERENCES

The standards listed below contains provisions which, through reference in this text, constitute provisions of this standard. At the time of publication, the editions indicated were valid. All standards are subjected to revision, and parties to agreements based on this standard are encouraged to investigate the possibility of applying the most recent editions of the standards listed below:

<i>IS No.</i>	<i>Title</i>
210: 2009	Grey iron castings — Specification (<i>fifth revision</i>)
IS 2500 (Part 1) : 2000/ ISO 2859-1:1999	Sampling procedures for inspection by attributes: Part 1 Sampling schemes indexed by acceptance quality limit (AQL) for lot-by- lot inspection (<i>third revision</i>)
IS 4905 : 2015/ ISO 24153: 2009	Random sampling and randomization procedures (<i>first revision</i>)

3 NOMENCLATURE

The nomenclature shall be as shown in Fig. 1.

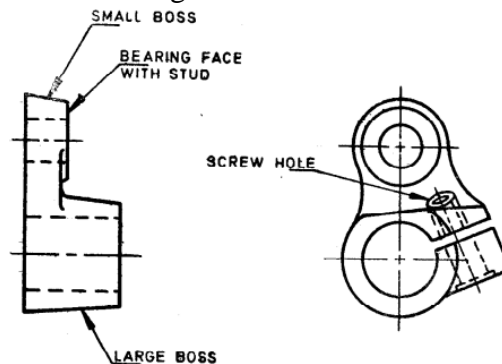

FIG. 1 NOMENCLATURE FOR FEED LIFTING ROCK SHAFT CRANK

4 MATERIAL

The feed lifting rock shaft crank shall be made from cast iron conforming to grade FG 150 of IS 210.

5 DIMENSIONS

The dimensions shall be as shown in Fig. 2.

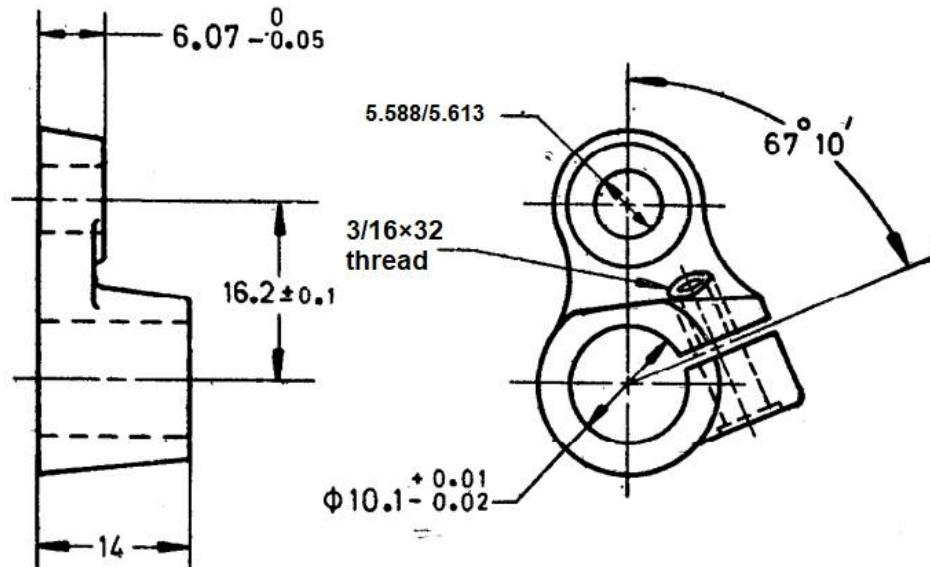

All dimensions in millimetres.

FIG. 2 DIMENSIONS FOR FEED LIFTING ROCK SHAFT CRANK

6 TOLERANCES

6.1 The error in parallelism of the axis of the main holes of the feed lifting rock shaft crank shall be within 0.30 mm per 100 mm.

6.2 The error in the squareness of the bearing faces with respect to the main holes shall not exceed 0.30 mm per 100 mm.

7 WORKMANSHIP AND FINISH

7.1 The main holes of the feed lifting rock shaft crank shall be finished to a good finish,

7.2 The bearing faces of the bosses of feed lifting rock shaft crank shall be machined to a fine finish without any line mark.

7.3 The castings shall be free from defects, such as cracks, flaws, or blow-holes and shall be chemically coloured or suitably plated.

8 MARKING

The feed lifting rock shaft cranks shall be marked with the manufacturer's name or trademark if required.

8.1 BIS Certification Mark

The product(s) conforming to the requirements of this standard may be certified as per the conformity assessment schemes under the provisions of the *Bureau of Indian Standards Act, 2016* and the Rules and Regulations framed thereunder, and the product(s) may be marked with the Standard Mark.

9 PACKING

Each feed lifting rock shaft crank shall be given a suitable anti-rust coating or wrapped in vapour phase inhibitor paper (commonly known as VPI paper). The wrapped feed lifting rock shaft cranks shall be securely packed in accordance with the best prevalent trade practice. Each packing shall bear the manufacturer's name or trade-mark, the type and description of contents,

10 SAMPLING

10.1 Unless otherwise agreed between the supplier and the purchaser, the sampling plan as given in Annex A shall be followed. For further information, reference may be made to IS 2500 (Part 1) / ISO 2859-1.

ANNEX A
(*Clause 10.1*)
SCALE OF SAMPLING AND CRITERIA FOR CONFORMITY

A-1 SCALE OF SAMPLING

A-1.1 Lot

In any consignment, all the feed rock shaft cranks of the same type and manufactured from the same material under essentially similar conditions of manufacture shall be grouped together to constitute a lot.

A-1.2 For ascertaining the conformity of the lot to the requirements of the specification, tests shall be carried out for each lot separately. The number of feed rock shaft cranks to be selected at random for this purpose shall be in accordance with column (2) and (3) of Table 1.

A-1.3 If the feed rock shaft cranks are packed individually, in order to ensure the randomness of selection, IS 4905 / ISO 24153 shall be used.

A-1.4 If the feed rock shaft cranks are packed in different cartons, a suitable number of cartons (not less than 20 percent of the total in the lot subject to a minimum of 2) shall be chosen at random. From each of the cartons so chosen, an approximately equal number of feed rock shaft cranks shall be picked up from its different parts so as to obtain the required number of feed rock shaft cranks specified in column (3) of Table 1.

A-2 NUMBER OF TESTS AND CRITERIA FOR CONFORMITY

A-2.1 The feed rock shaft crank selected according to **A-1.2** and **A-1.3** or **A-1.4** shall be examined for dimensions (*see 5*), tolerances (*see 6*), and workmanship and finish (*see 7*). If the number of feed rock shaft cranks failing to meet one or more of the requirements mentioned above is less than or equal to the permissible number of defectives given in column (4) of Table 1, the lot shall be declared as conforming to the requirements of these characteristics.

Table 1 Scale of Sampling and Permissible Number of Defectives
(*Clauses A-1.2, A-1.4, and A-2.1*)

Sl No.	Number of Feed Rock Shaft Cranks <i>N</i>	For Dimensions, Tolerances, Workmanship and Finish Sample Size <i>n</i>	Permissible Number of Defectives*
(1)	(2)	(3)	(4)
i)	Up to 15	5	0
ii)	16 to 40	8	0
iii)	41 to 110	13	0

iv)	111 to 300	20	1
v)	301 to 500	32	1
vi)	501 to 800	50	2
vii)	801 to 1 300	80	3
viii)	1 301 and above	125	5

*This ensures that lots containing only 1.5 percent or less defectives shall be accepted most of the time.