

For BIS Use Only

BUREAU OF INDIAN STANDARDS

DRAFT FOR COMMENTS ONLY

(Not to be reproduced without the permission of BIS or used as an Indian Standard)

भारतीय मानक मसौदा

**औद्योगिक और वाणिज्यिक अनुप्रयोग के लिए बास्केट और
बाउल और कंपन प्रकार के सेंट्रीफ्यूज — विशिष्टि**

भाग 1 सामान्य अपेक्षाएं

(आई एस 4092 (Part 1) का तीसरा पुनरीक्षण)

Draft Indian Standard

**Centrifuges of the Basket and Bowl and Vibrating Type for use in
Industrial and Commercial Applications — Specification**

Part 1 General Requirements

(Third Revision of IS 4092 (Part 1))

ICS 71.120

Chemical Engineering Plants and Related Equipment Sectional
Committee, MED 17

Last date of recipient of comments
is **20 March 2024**

FOREWORD

(Formal clause to be added later)

The aim of this standard is to specify the materials and methods of manufacture, operating procedures and accessories required for the safe operation of centrifuges and also to ensure sufficient information is made available from the manufacturer and user to enable an inspection authority to determine the degree of safety and hence the suitability of the equipment for the duty.

This standard was originally issued in 1971, and subsequently revised in 1984 and 1992. The present revision has been taken up with a view incorporating the modification found necessary as a result of experience gained in the use of this standard. Also, in this revision, the standard has been brought into the latest style and format of Indian Standards, and references to Indian Standards, wherever applicable have been updated. BIS certification marking clause has been modified to align with the revised *Bureau of Indian Standard Act, 2016*.

For the purpose of deciding whether a particular requirement of this standard is complied with, the final value, observed or calculated, expressing the result of a test or analysis, shall be rounded off in accordance with IS 2 : 2022 'Rules for rounding off numerical values (*second revision*)'. The number of significant places retained in the rounded off value should be the same as that of the specified value in this standard.

1 SCOPE

1.1 This Indian Standard (Part 1) specifies design, materials, methods of construction, inspection and testing of centrifuges of the basket and bowl and vibrating types for use in industrial and commercial applications. To assist manufacturers and users to fulfil their obligations towards Health and Safety, information is included covering safe access and safe working. Additional provisions necessary for handling highly flammable and/or toxic substances are also included.

1.2 Tube and bottle type centrifuges as used in laboratories are excluded from this standard. High speed gas centrifuges used for the enrichment of fissile material are also excluded.

1.3 The handling of explosive or biologically hazardous materials and also the use of non-metallic material for stressed parts of rotating assemblies is outside the scope of this standard.

2 REFERENCES

2.1 The standards listed below contain provisions, which, through reference in this text, constitute provisions of this standard. At the time of publication, the editions indicated were valid. All standards are subject to revision, and parties to agreements based on this standard are encouraged to investigate the possibility of applying the most recent editions of the standards listed below:

<i>IS No.</i>	<i>Title</i>
IS 554 : 1999	Dimensions for pipe threads where pressure-tight joints are made on threads (<i>third revision</i>)
IS 2063 (Part 5) : 2016/ ISO 230-5 : 2000	Test code for machine tools: Part 5 determination of the noise emission
IS 2825 : 1969	Code for unfired pressure vessels
IS 4682 (Part 1) : 1994	Code of practice for lining of vessels and equipment for chemical processes: Part 1 Rubber lining
IS 4682 (Part 2) : 1969	Code of practice for lining of vessels and equipment for chemical processes: Part 2 Glass enamel lining
IS 4682 (Part 3) : 1969	Code of practice for lining of vessels and equipment for chemical processes: Part 3 Lead lining
IS 4682 (Part 4) : 1998	Code of practice for lining of vessels and equipment for chemical processes: Part 4. Plasticized PVC
IS 4682 (Part 5) : 1970	Code of practice for lining of vessels and equipment for chemical processes: Part 5 Epoxide resin lining
IS 4682 (Part 6) : 1970	Code of practice for lining of vessels and equipment for chemical processes: Part 6 Phenolic resin lining
IS 4682 (Part 7) : 1974	Code of practice for lining of vessels and equipment for chemical processes: Part 7 Corrosion and heat resistant metals
IS 4682 (Part 8) : 1974	Code of practice for lining of vessels and equipment for chemical processes: Part 8 Precious metals

IS 4682 (Part 9) : 1974	Part 9 Titanium
IS 4682 (Part 10) : 1974	Part 10 Brick and tile
IS/ISO 21940-11 : 2016	Mechanical vibration - Rotor balancing: Part 11 procedures and tolerances for rotors with rigid behaviour

3 DEFINITIONS

For the purpose of this standard the following definitions shall apply.

3.1 Centrifuge

A machine in which extraction or separation of a liquid from a solid and/or separation of immiscible fluids is achieved by centrifugal action.

NOTE - Illustrations of some basic types of centrifuges are given in Annex A.

3.2 Batch Centrifuge

A machine that processes a discrete batch of feed material. It may be automated to go through a sequence of feeding, washing, and spinning. Solids discharge may be either automatic, the solids being removed either at full speed or at a low speed, or the machine may be stopped for manual removal of the material, solid waste or product.

3.3 Continuous Centrifuge

A machine that takes a continuous feed of material, giving a continuous discharge of liquor. Solids are removed either continuously or intermittently

3.4 Pusher Centrifuge

A continuous filtering machine with an oscillating mechanism for discharge of solids.

3.5 Decanter Centrifuge

A continuous sedimentation machine with an internal screw mechanism for removal of settled solids from a rotating bowl.

3.6 Disc Bowl Centrifuge

3.6.1 A continuously fed sedimentation machine provided with a number of equally spaced conical discs between which the feed passes. Solids are removed from the bowl either manually, or as a slurry via nozzles or by a bowl opening mechanism.

3.7 Textile Centrifuge

A machine used in dry cleaning, laundering and textile processes to extract liquid from textile materials or articles.

3.8 Basket

That part of a centrifuge, arranged to rotate about its axis, having a perforate shell in which the liquid is separated from the solid component.

3.9 Bowl

That part of a centrifuge arranged to rotate about its axis, having an imperforate shell for the separation of immiscible liquids and/or the sedimentation of solids.

3.10 Spindle

The shaft or shafts on which the basket or bowl is carried.

3.11 Rotor

The part of the centrifuge that rotates, comprising basket or bowl and spindle together with attachments.

3.12 Casing

The stationary casing surrounding the basket or bowl, adapted to receive the separated products and having means for their discharge.

3.13 Plough

A device for the removal of centrifuged solids from the rotating basket or bowl.

3.14 Screw Conveyor

A helical screw device mounted either within the bowl or basket and rotating concentrically with it or statically mounted as part of the casing so as to feed or discharge solids.

3.15 Hoops

Rings secured to the outer periphery of a centrifuge basket to give extra strength.

3.16 Bumping Ring

A device to limit radial movement of the rotor. The bowl or shaft will normally run freely within the bumping ring.

3.17 Screen

A medium, usually metallic, used as an alternative to a cloth within the rotating assembly for the purpose of solids retention or as a support for a filter cloth.

3.18 Cover or Closure for Basket

A detachable cover fitted in a centrifuge basket that holds the contents in position during rotating and is used to facilitate manual loading of the basket or lifting out of a filter bag.

3.19 Inspection Cover or Port

An integral part of the centrifuge casing that is bolted, clamped or otherwise secured before the rotor is set in motion. It may be removed or opened for maintenance, inspection, lubrication or cleaning purposes.

3.20 Cover (or Lid)

A plate or door forming part of the casing that, when closed or secured, prevents persons from coming into contact with moving parts, from becoming entangled with any material in motion within and from being splashed or affected by fumes from the machine.

3.21 Interlock

A device using mechanical, electrical, pneumatic or hydraulic components, or any combination of these, that prevents an action or motion taking place until some specified safe or predetermined condition has been established. In addition, it will normally continue to prevent an unsafe situation occurring.

3.22 Classification of Hazardous Areas

An international system that recognizes three orders of probability of fire explosion associated with the possible presence of flammable gases or vapours in a geographical area, namely Zone 0, Zone 1 and Zone 2 in decreasing order of severity.

3.23 Combustion

Consumption by oxidation, with the production of heat, usually with incandescence or flame or both.

3.24 Flammable

Capable of burning in air with a flame.

3.25 Highly Flammable

Any substance that gives off a flammable vapour at a temperature of less than 32°C and when tested in the specified way for combustibility, supports combustion.

3.26 Flash Point

The lowest temperature at which a liquid gives off sufficient flammable vapour in air to produce a flash on the application of a small flame.

3.27 Inert Gas

A gas that cannot support combustion. (For practical purposes, usually nitrogen, but argon, flue gas or carbon dioxide are occasionally used when suitable and available).

3.28 Inert Gas Blanket

A system where the oxygen content within an enclosure is reduced by the use of an inert gas to a concentration at which an explosive atmosphere cannot form.

3.29 Operating Speed of a Centrifuge

The speed measured in revolution per unit time at which the rotor is expected to revolve either continuously or at each part of a multi-speed programme.

3.30 Permissible Speed of a Centrifuge

The maximum allowable speed of the rotor determined from stress considerations allowing the appropriate factor of safety.

3.31 Frame

The major stationary part that supports the rotor. The centrifuge casing is normally mounted on the frame.

3.32 Highly Stressed Parts

Those parts where the calculated stress is equal to or above 75 percent of the maximum permitted stress.

3.33 Medium Stressed Parts

Those parts where the calculated stress is below 75 percent and above 50 percent of the maximum permitted stress.

3.34 Low Stressed Parts

Those parts where the calculated stress is equal to or below 50 percent of the maximum permitted stress.

4 MATERIALS OF CONSTRUCTION

4.1 General

Materials shall conform to appropriate Indian standards. The manufacturer and user shall agree a specification including chemical analysis and mechanical properties required when materials chosen are other than those specified in Indian Standards.

They shall also agree the amount and type of testing needed to demonstrate that the agreed specifications are met.

NOTE - Safety is dependent upon the integrity of the rotating assembly. No level of containment is specified.

4.2 Major Parts

4.2.1 *Rotating Parts*

Major parts of centrifuges subject to stress due to speed of rotation shall be manufactured from a ductile material having an elongation of not less than 12 percent and an impact test value of not less than 12 percent and an impact test value of not less than 25 J at 20°C. Any heat treatment to which the unit has been subjected shall be recorded by the machine manufacturer and made available to the user on request.

4.2.2 Parts Subject to Corrosion, Abrasion, Erosion or Low Temperature Conditions

These parts shall be manufactured from a material specified in Indian Standard where available.

4.2.2.1 Materials for use at sub-zero temperatures shall meet the design requirements at the minimum operating temperature.

NOTE - The manufacture of stressed Parts of rotating assemblies in non-metallic materials is not covered by this standard.

4.2.3 Testing of Materials

Test shall be made on the materials for major items of construction to establish that the specified property requirements are fulfilled and that the materials comply with the relevant standard.

NOTE -The values given in 4.2.1 refer to tests on separately cast or forged test pieces. Calculations of the bowl/basket strength and the certificates of physical properties and chemical analysis shall be made available to the customer upon request. The request shall be made at the time of enquiry.

Calculations of the bowl/basket strength and the certificates of physical properties and chemical analysis shall be made available to the customer upon request. The request shall be made at the time of enquiry.

4.3 Protective Lining Materials and Surface Coverings

4.3.1 Testing of Lining

Inspection and test procedures specified in IS 4682 (Parts 1 to 10) shall be used, or in the case of a thick lined basket or bowl with non-conductive lining the procedure given in 4.3.2 shall be adopted.

NOTE - Lining materials and surface coverings are not specified but for guidance general requirements are listed in Appendix B

4.3.2 Procedure

Partially submerge the basket, with its spindle in a horizontal position, in water containing less than 0.1 percent of sulphuric acid! The spindle being above the level of the liquid. Apply a voltage of not less than 1000 V a.c. between the spindle (which is electrically connected to the metal of which the basket is composed) and the liquid, and rotate the basket slowly through one revolution. No defect in the covering shall become visible during the test.

4.4 Materials for Casings and Other Wetted Components

Material for casings and other wetted components shall be chosen to suit the duty, for example abrasive, corrosive, erosive, high or low temperature.

5 METHODS OF CONSTRUCTION

5.1 Casting, Forging Rolling or Welding

Basket and bowl cylindrical and conical sections shall be made from castings, forgings or rolled and welded fabrications.

5.2 Bolting and Riveting

Where basket or bowl cylindrical and conical shells are joined to the ends by bolting or riveting, the manufacturer shall state the design stress to be applied to bolts or rivets during assembly.

NOTE - The means by which this stress may be determined should be agreed between the manufacturer and the user.

5.3 Fabrication by Welding

5.3.1 Welding for highly stressed parts and welder's approval shall be done in accordance with **6.7** and **7.2** of IS 2825. Welded joints shall comply with **6.2** of IS 2825. If pre or post-heat-treatment is necessary it shall be as per **6.12** of IS 2825. There shall be 100 percent NDT in accordance with **8.7** of IS 2825 after all heat treatment is completed. Defects shall be assessed as per **8** of IS 2825. On completion of heat treatment, radiographic or ultrasonic examination shall be carried out, as given in either (a) or (b).

- a) A minimum of 10 percent of the weld length shall be subject to radiographic or ultrasonic examination; this examination shall be carried out at all welded joint intersections and on part of every seam. Where an opening occurs in any welded seam or within a distance equal to the metal thickness, radiographic or ultrasonic examination shall be carried out at each side of the opening over a length of approximately 100 mm.
- b) A 100 percent radiographic or ultrasonic examination shall be carried out on a random 10 percent of any batch.

5.3.2 The welding of low stressed parts shall be in accordance with written procedures and shall be subject to visual inspection. The acceptance criteria for defects shall form part of or be appended to the written procedure.

5.3.3 Visual examination shall accompany all non-destructive testing and the examination result shall be recorded. A non-destructive testing specification shall be provided by the manufacturer for each centrifuge type.

5.4 Repair of Defects

Where examination reveals unacceptable defects 100 percent examination shall be made. The rectification of unacceptable defects shall be carried out using a written approved method and shall be subjected to the same examination as the original work using the same acceptance criteria.

6 STRENGTH OF BASKETS OR BOWLS

6.1 Cylindrical Baskets or Bowls

The strength of cylindrical baskets or bowls shall be determined using the methods of stress analysis specified in Annex C.

The shells shall be of uniform thickness and shall be either unperforated or have round perforations.

The ratio of shell thickness/basket radius shall be not greater than 0.1.

The maximum permitted stress (f_t) shall not exceed the smaller of the following two values:

$$f_t \leq 0.5f_Y$$

$$f_t \leq 0.33f_R$$

Where,

f_R is the ultimate tensile strength (in N/mm²);

f_y is the yield point stress for steels with marked yield point (in N/mm²), or 0.2% proof stress for steels without marked yield points (in N/mm²), or 1.0% proof stress for austenitic steel (in N/mm²).

6.2 Other Baskets or Bowls

The criteria to be used in assessing calculated stresses shall be in accordance with Annex A of IS 2825.

NOTES

1 A finite element technique is considered to be the most suitable for stress analysis of a rotating basket or bowl.

2 The purchaser and the manufacturer should agree at the time of the order the fatigue design conditions, if any, to be evaluated having regard to the available service experience and experimental information.

The maximum permitted stress shall be determined from the equations given in **6.1**.

Each type of basket or bowl designed in accordance with this subclause shall be tested to demonstrate the integrity of the type and this test shall include a test at a speed and load sufficient to produce 125 percent of the design stress for 30 min.

7 DESIGN REQUIREMENTS

7.1 Casing

The casing including doors, covers, lids and their fixings shall be secured either to the frame of the machine or the foundation and shall be sufficient to robust and of a suitable thickness to meet the duties specified and other predicted conditions. The thickness of any lining shall be in addition to the case thickness. A bumping ring shall be fitted to the casing of any centrifuge if the basket is liable to oscillate relative to the casing. The casing shall provide adequate sealing against leakage of process fluid, gas or vapour.

7.2 Basket or Bowl Construction

7.2.1 Hoops

The basket or bowl shall be either unhooped or hooped. When hooped the spacing shall be symmetrical.

7.2.2 Joins in Basket or Bowl Material

The manufacturer shall provide to the user evidence that the method of joining shell material is adequate for the proposed duty.

7.2.3 Perforations and Holes

Perforations and holes shall be drilled or shall be produced by a method that induces stresses no higher than those caused by drilling.

NOTE - If the calculated circumferential stress is below 60 N/mm² holes or perforations may be punched.

7.3 Spindle and Couplings

The spindle and couplings shall be shown to be adequate for the maximum driving and braking torque and for the manufacturer's specified out-of-balance loads.

7.4 Drives

For batch centrifuges, the duty cycle and rating of the machine shall be agreed to between the centrifuge manufacturer, motor manufacturer and user.

7.5 Balancing and Limits of Vibration

7.5.1 Rotor Balance

The centrifuge manufacturer shall state the balance quality of a rotor in accordance with IS/ISO 21940-11 in the new condition and, if different, the permissible value to which a used rotor should be balanced. The method of achieving balance shall be clearly visible on an assembled rotor and shall be recorded at the time it is applied. The manufacturer shall indicate zones where corrective balancing action may be applied and state his recommended method of achieving balance.

7.5.2 Vibration Intensity

The limits of vibration intensity as specified in Indian Standard for vibration levels for machine tools, vibration amplitude at which the machine may be allowed to operate, shall be stated by the centrifuge manufacturer.

7.6 Locking and Fatigue Strength of Bolted Parts

7.6.1 Rotating Parts

Bolted connections on all rotating parts shall be locked, by tab washer, spring washers, locking wire, or upsetting (peening), double nuts shall not be used. All bolting on rotors shall be to an agreed fatigue resistant design. The manufacturer shall state the required torque loading or necessary bolt extension in the maintenance manual.

7.6.2 Stationary Parts

Bolts fitted to stationary parts which, if they should loosen, could come into contact with the rotor, shall be to a fatigue resistant design and shall be locked.

7.7 Direction and Speed of Rotation

7.7.1 General

The direction of rotation, and the permissible speed shall be marked on the machine in a permanent manner (*see 15*).

7.7.2 Measurement

Suitable provision shall be made for the measurement of the speed of rotation.

7.8 Accessories

All accessories required for the safe operation of the centrifuge at the required duty shall be specified by the centrifuge manufacturer and shall include information on gearboxes, solids removal equipment, lubrication and sealing systems.

7.9 Screw Threads

Screw threads shall be consistent throughout the machine and shall confirm to IS 554.

7.10 Connections

The centrifuge manufacturer shall state the maximum force and movement to which connections may be subjected in compression, tension, bending and torque. Centrifuges located on anti-vibrational mountings or vibration isolators require all connections to the machine to be sufficiently flexible to accommodate predicted movements.

7.11 Foundations

The machine manufacturer shall provide, on request by the user, recommendations in the form of drawings showing forces on foundations and the recommended methods of attaching machines to the foundations. In particular manufacturers shall give information on the forcing frequencies to which the foundation will be subjected.

7.12 Over-Pressure Protection

Where required by the user the maximum allowable operating pressure for the centrifuge casing shall be stated by the manufacturer. The design contractor and user shall ensure that the centrifuge casing is provided with an over-pressure protection device. Sources of possible over-pressure from associated equipment, for example feed systems, product discharge systems dryers and wash supplies, shall be considered. The manufacturer shall also provide over-pressure protection for any other pressurised system on the centrifuge such as an oil lubrication system where appropriate.

8 GUARDS, INTERLOCKS AND SAFE WORKING

Principles to be used and the methods that may be applied in safeguarding the machinery shall be according to relevant Indian Standards wherever available. A person may be injured at centrifuges as a result of for example:

- a) Corning into contact with, or being trapped by the machinery;
- b) Being struck, trapped or entangled in or by any material in motion in the machinery;
- c) Being struck by parts of the machinery ejected from it;
- d) Being struck by material ejected from the machinery;
- e) Being scalded, burned or splashed by liquids being fed to or ejected from the machine;
- f) Being affected by gas or fumes from the machine.

8.1 Guards

8.1.1 All doors, inspection covers, lids and guards shall be secured by means which necessitate the use of a tool for removal unless interlocks are provided in accordance with **8.2**.

8.1.2 When the process conditions allow and when it is necessary to wash down, feed or inspect whilst the machine is in motion, suitable guarding shall be fitted to prevent persons coming into contact with moving parts.

NOTE - Fixed guards should be used whenever practicable.

8.2 Interlocks

8.2.1 Interlocks shall be designed to ensure that the centrifuge remains in a safe condition if the interlock or its power supply fails.

8.2.2 Any centrifuge not protected as specified in **8.1.1** shall be equipped with devices designed to ensure that it cannot be started until doors, covers, lids and/or guards have been closed and secured and that access cannot subsequently be gained until linear and rotational motion have ceased. Machines fitted with rotational sensing devices shall be considered stopped at speeds below 9 rev/min.

8.2.3 If a drive mechanism is employed which is capable of driving the centrifuge at a speed higher than its permissible speed, a speed control and an overspeed prevention device shall be provided.

8.2.4 When a basket type centrifuge is fitted with a low speed plough discharge device, an interlock shall be fitted to avoid the possibility of the plough operating at a basket speed higher than that for which it was designed.

8.2.5 For a ploughing type centrifuge, interlock shall be fitted which will:

- a) prevent the starting of the main drive of the centrifuge unless the plough unit is in the parked (that is, withdrawn) position.
- b) prevent feed valves opening on the first or subsequent cycles until the basket is rotating at its normal feed speed, and the plough is in the parked position.

8.2.6 A centrifuge provided with an independent oil lubrication supply shall have an interlock to prevent the main drive starting until the lubrication system is functional. Failure of the lubrication system shall trip the centrifuge drive and stop the feeds.

8.3 Other Safety Features

8.3.1 Any centrifuge operating on a duty likely to give excessive out-of-balance forces shall be fitted with a vibration alarm and a high vibration trip which will initiate appropriate action to reduce the out-of-balance forces.

NOTE - Consideration should be given to fitting vibration monitoring equipment to all centrifuges.

8.3.2 Centrifuge installations shall be effectively earthed and any non-conducting sections of pipework shall be bridged with an earth conductor.

NOTE.— Drive belts of anti-static material should be used.

8.3.3 A rigid mechanical back-up stop shall be provided for a ploughing type centrifuge to prevent the plough blade tearing into the cloth or basket unless the design of the plough geometry inherently prevents this occurrence.

8.3.4 Electrical heaters fitted in the centrifuge oil systems shall be rated at not more than 30 kW/ma and fitted with a high temperature trip device.

8.3.5 A centrifuge drive shall be so designed that in the event of a trip it can only be manually re-started.

8.3.6 The application of any brake shall automatically isolate the main drive mechanism unless the drive system is used as a brake.

8.3.7 Centrifuges incorporating a lift-out basket and/or a lift-out basket lid arrangement shall have devices to prevent start-up until the basket and/or lid have been correctly located and locked into position.

NOTE - Consideration should be given to the provision of adequately sized inspection windows, fixed light with internal wash or scraper facility and the provision of internal casing flush facilities to obviate the necessity of opening up the machine for process reasons.

9 NOISE LEVEL

9.1 Installation, Maintenance and Operation The supplier shall provide information, on the correct method of installation, maintenance, and use to control noise and details of noise levels measured in accordance with IS 2063 (Part 5).

NOTE - Machines should be designed, constructed installed and maintained so as to perform their function as quietly as is reasonably practicable.

10 PROCESSING FLAMMABLE MATERIALS

10.0 This clause deals with the processing of flammable materials. The processing of explosive materials is outside the scope of this standard. Levels of risk are detailed in Annex D.

10.1 General

10.1.1 Where a high level of risk exists an inert gas blanket system shall be provided together with an interlock system designed to prevent the machine being started until the oxygen within the machine has been reduced to a safe concentration. The oxygen content shall be monitored continually unless a pressure and flow controlled purging system is used. A pressure and flow controlled system shall be monitored by external means at specified intervals. The system shall provide an extra flow of inert gas the oxygen content increases above the alarm condition given in **10.4**. Automatic isolation of feeds and machine drive shall be provided if the oxygen concentration exceeds a specified level or the purging system fails.

NOTE - Vibration sensing, a vibration alarm and high vibration trip should be fitted. It is essential to ensure that the trip initiates appropriate action to reduce the vibration.

10.1.2 Where a moderate level of risk exists an inert gas blanket system shall be provided.

NOTES

1 Precautions should be taken at start-up (for example, by use of a portable oxygen analyser) to ensure that the oxygen has been reduced to a safe concentration. During operation the oxygen content of the machine should be monitored once every working shift.

2 Vibration sensing should be fitted (*see* Note to **10.1.1**).

10.1.3 Where a low level of risk exists precautions shall be taken to avoid any temperature which could produce a flammable atmosphere.

NOTE - Consideration should be given to fitting vibration monitoring equipment.

10.2 Oxygen Concentrations for Inert Gas Blanket Systems

The following upper limits of concentration shall not be exceeded (*see* **10.1**):

1. Start-up of centrifuge drive: 2%;
2. Automatic shut-off of feed and/or wash supplies, with alarm: 5% ; and
3. Automatic trip of machine drive: 8%.

10.3 Other Safety Features for Handling Flammable Materials

10.3.1 Inert gas feed points shall be located to avoid stagnant vapour pockets during the initial purge.

NOTES

- 1 Separate lines may be necessary to feed inside the basket, product chute, casing and bearing housing.
- 2 It is essential to ensure that precautions are taken to prevent air entering the centrifuge system during operation, for example, through feed or wash routes, inspection ports, sampling points labyrinth seals etc.
- 3 It is essential to ensure that gas sample points are sited to ensure that representative samples are obtained and short circuiting from inert gas supply points is avoided.
- 4 Provision should be made to prevent overpressurizing the centrifuge or its oil system by the inert gas supply.

10.3.2 An atmosphere which is safe to breathe shall be provided inside a machine having an inert gas system whenever internal access is required. An interlock shall be provided to prevent the flow of inert gas when a machine is opened as part of its normal operation. Other machines shall have provision to prevent the flow of inert gas whenever they are open.

10.3.3 Machines provided with friction brakes or clutches shall be designed to minimize the risk of process fluid ingress to the clutch/brake housing which shall be purged with solvent free air provided by an independent ventilating fan interlocked electrically with the main drive. A friction clutch or brake shall be contained in a housing sealed from the process fluid and supplied with a purge gas flow. The purged condition shall be maintained when the machine is in operation.

NOTE -Friction brakes and clutches should be avoided where possible to reduce the risk of sparking and overheating.

10.3.4 Where a centrifuge is fitted with a friction brake, an interlock shall be provided to prevent the centrifuge from being set in motion until the brake is released. The application of any such brake shall automatically isolate the main drive mechanism.

11 PROCESSING TOXIC MATERIALS

11.1 The centrifuge system shall be designed to prevent the release of materials harmful to health into the work area and to allow the machine to be maintained safely. The degree of containment shall be related to the potential hazard including the toxicity of the material and to any relevant threshold limit values or other hygiene standards.

NOTES

- 1 The main areas where leaks occur, are:
 - a) joints and seals;
 - b) flexible connections; and
 - c) feed and discharge conveying equipment.
- 2 The main areas where hazards to maintenance operators occur, are:
 - d) crevices and inaccessible locations;
 - e) poor surface finish; and
 - f) trapped toxic material.

Leaks may be reduced by operating below atmospheric pressure inside the machine. Any pressure relief device or extraction system shall vent to a safe place.

11.2 There shall be provision to decontaminate a machine and check that a safe condition has been achieved before maintenance work starts. If both toxic and flammable conditions exist in the machine then the provisions of clause **10** shall apply in addition to the requirements specified in **11**.

NOTES

- 1 In order to comply with **11** it is essential to ensure the system operates above atmospheric pressure.

2 The provision of secondary enclosures (for example, special rooms or ventilated cabinets) or siting in well ventilated areas may be necessary. Regular monitoring of the work area is essential to check that the permissible concentration of the toxic material is not higher than expected.

12 INSPECTION AND TESTING

12.1 Test at Manufacturer's Work

12.1.1 Materials

The manufacturer shall provide evidence, when requested at the time of enquiry, the materials used in the construction of the centrifuge comply with the property requirements of **4**.

12.1.2 Assemblies

The manufacturer shall provide evidence of radiographic (or equivalent) examinations of stressed welds in bowls or baskets where a weld factor greater than 0.8 has been used in the stress calculations given in **C-3.2.2**. The manufacturer shall provide evidence that all linings meet the test requirements of **4.3.1**.

12.1.3 Centrifuge

Casing pressure, lubrication system and seals system tests shall be carried out where applicable. Dynamic tests shall be carried out up to the permissible speed to ensure that the centrifuge meets the mechanical design specifications. These tests shall include the following and the results shall be available to the user on request:

- a) starting time;
- b) stopping time;
- c) vibration severity;
- d) noise level;
- e) the correct functioning of controls, interlocks and monitoring instruments.

NOTES

1 The manufacturer should afford the purchaser or his representative all reasonable facilities, including access to the works during manufacture to verify that the centrifuge is in accordance with this Indian Standard.

2 Manufacturers should supply the labour and appliances for such testing as may be carried out on their premises to satisfy the purchaser that the materials used for the construction of the basket comply with the relevant specifications. In the absence of facilities at their own works for making the prescribed tests, the manufacturer shall arrange for the tests to be carried out elsewhere. The certificate of tests supplied by the manufacturer of the materials may be used as evidence that the materials used comply with the relevant specifications.

3 The manufacturer should make available all facilities for any additional inspection and test required by the purchaser as given in **F-1.6 (c)** provided the purchaser indicated, at the time the order is placed, that he wished to avail himself of the provisions contained in this clause.

12.2 Site Tests

The manufacturer and user shall agree the tests to be carried out to verify that the centrifuge meets design performance.

NOTE - Recommendations for periodic examination and testing are listed in Annex E.

13 INFORMATION TO BE SUPPLIED WITH ENQUIRY OR ORDER

The data listed in Annex F could be relevant and important in the supply of a centrifuge for a given duty and for safety reasons shall be supplied where available and known.

NOTE- Assistance should be provided by the potential supplier in completing the details required.

14 DATA SHEET

14.1 The data sheet shall contain the following information:

- a) User's name and address;
- b) Purchaser's order number and date;
- c) Identification of the source of manufacture;
- d) Type and size of centrifuge;
- e) Manufacturer's serial number and date of delivery;
- f) Date of manufacture;
- g) Materials of construction for wetted parts;
- h) Process duty;
- j) Stress calculations or test reference;
- k) Drive permissible speed;
- m) Drive type, power and speed;
- n) Gross weight of empty machine and drive in operation condition;
- p) Casing operating pressure range;
- q) Casing operating temperature range where appropriate.

15 MARKING

15.1 A nameplate, on which the following particulars are permanently and legibly marked shall be permanently fixed to the centrifuge in a prominent position:

- a) Identification of the source of manufacture,
- b) Manufacturer's type name and type number;
- c) Manufacturer's serial number;
- d) Date of manufacture;
- e) Permissible speed (rev/min);
- f) Direction of rotation (*see* Note);
- g) Maximum mass or density of contents, and
- h) The number of this Indian Standard.

NOTE – The direction of rotation indication may be separate from main nameplate if required but it is essential to ensure that it is in a prominent spinning and ploughing where appropriate.

15.2 BIS Certification Marking

The product(s) conforming to the requirements of this standard may be certified as per the conformity assessment schemes under the provisions of the *Bureau of Indian Standards Act, 2016* and the Rules and Regulations framed thereunder, and the products may be marked with the Standard Mark.

ANNEX A

(Clause 3.1)

ILLUSTRATIONS OF SOME BASIC TYPES OF CENTRIFUGE

A-1 Centrifuges may be used to separate solids from liquids by filtration or sedimentation. They may also be used, to separate immiscible fluids with or without mass transfer between the phases, and possibly with facilities for solids removal as an added variant.

Centrifuges used in the laundry, textile and dry cleaning industries separate solids (fabric) from liquid (wash water or solvent) by centrifugal filtration. Figure 1 is an illustration of a textile centrifuge. Subsequent illustrations show filtration and sedimentation machines, each category subdivided into batch and continuous versions. The list of illustrations is not exclusive; most of the common forms of machine are shown, but each type can usually be provided with several variations in detailed design to suit the intended process application. A list of figures illustrating basic types of centrifuges is given in Table 1.

Table 1 List of Figures Illustrating Basic Types of Centrifuge

(Clause A-1)

Types of Centrifuges	Figure
Textile centrifuge	1
Filtration machines:	
a) Batch centrifuges	
1) Three point suspension manual discharge	2
Automatic discharge	
i) Pendulum	3
ii) Horizontal spindle	4
iii) Three point suspension	5
b) Continuous centrifuges	
1) Basket centrifuges with extraction screw conveyor	6
2) Pusher	7
3) Self discharge conical	8
Sedimentation machines:	
a) Batch centrifuges	
1) Three point suspension	9
2) Tubular bowl	10
3) Chamber bowl	11
4) Disc bowl	12
b) Continuous centrifuges	
1) Nozzle discharge disc	13
2) Opening bowl	14
3) Solid bowl decanter	15
Combined sedimentation and filtration machine, screen bowl decanter	16

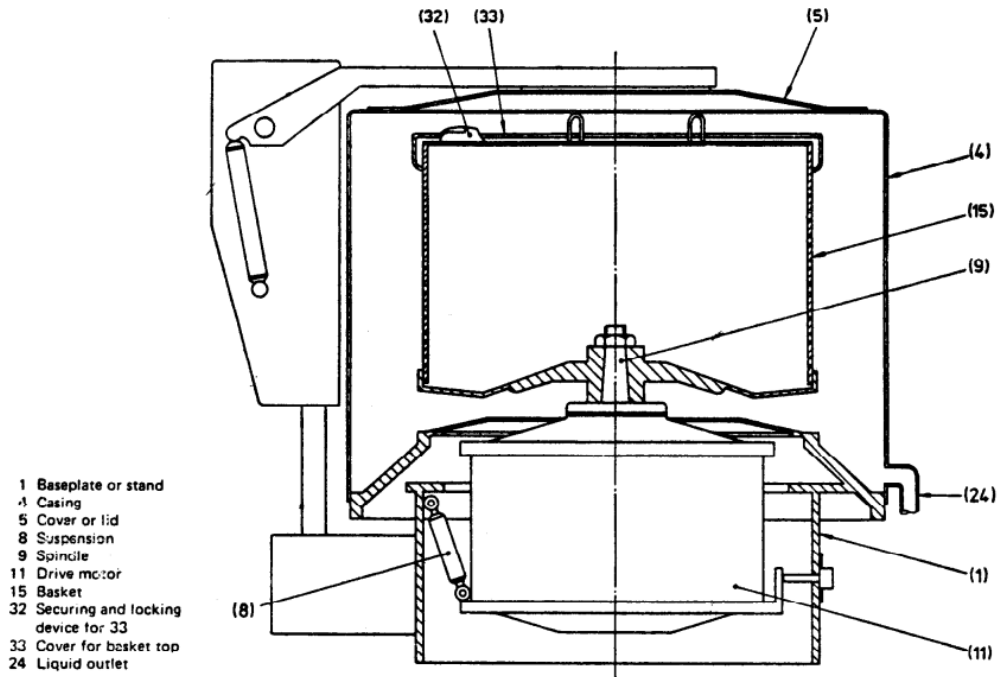

FIG. 1 TEXTILE CENTRIFUGE

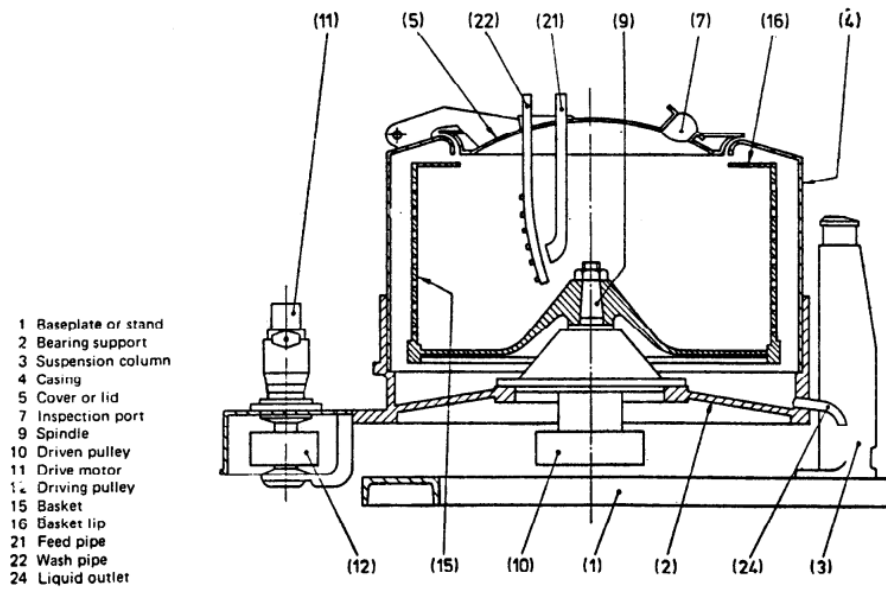

FIG. 2 THREE POINT SUSPENSION, MANUAL DISCHARGE, BATCH CENTRIFUGE, FILTRATION MACHINE

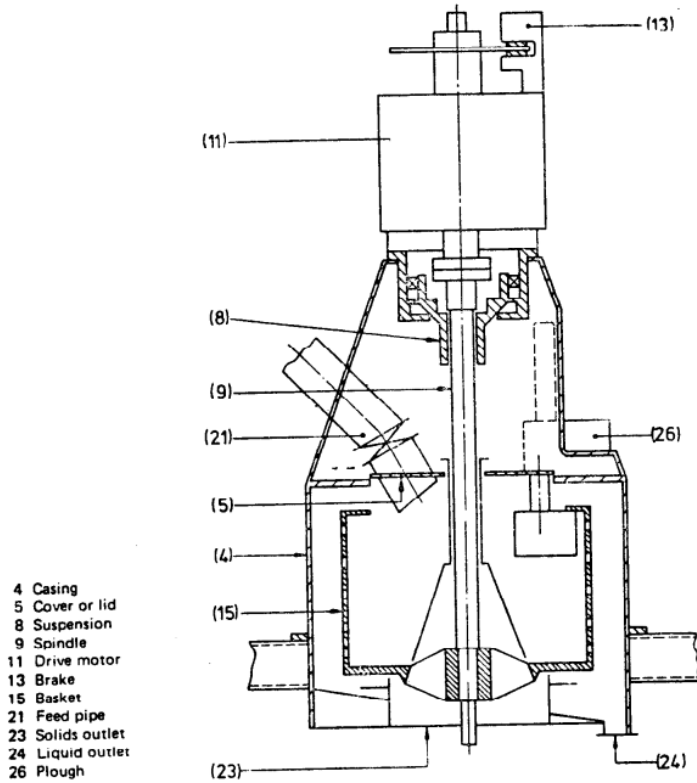

FIG. 3 PENDULUM, AUTOMATIC DISCHARGE, BATCH CENTRIFUGE, FILTRATION MACHINE

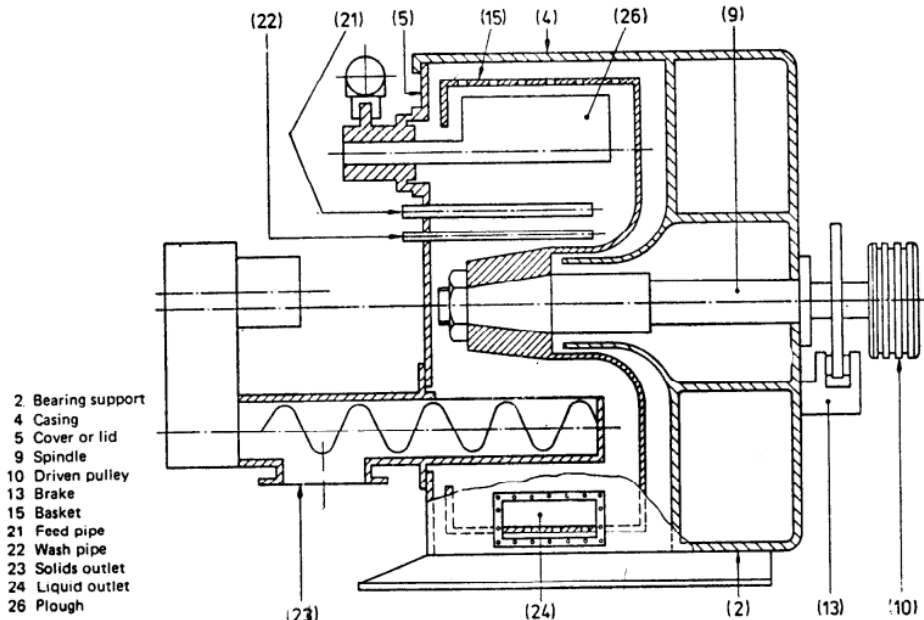

FIG. 4 HORIZONTAL SPINDLE, AUTOMATIC DISCHARGE, BATCH CENTRIFUGE, FILTRATION MACHINE

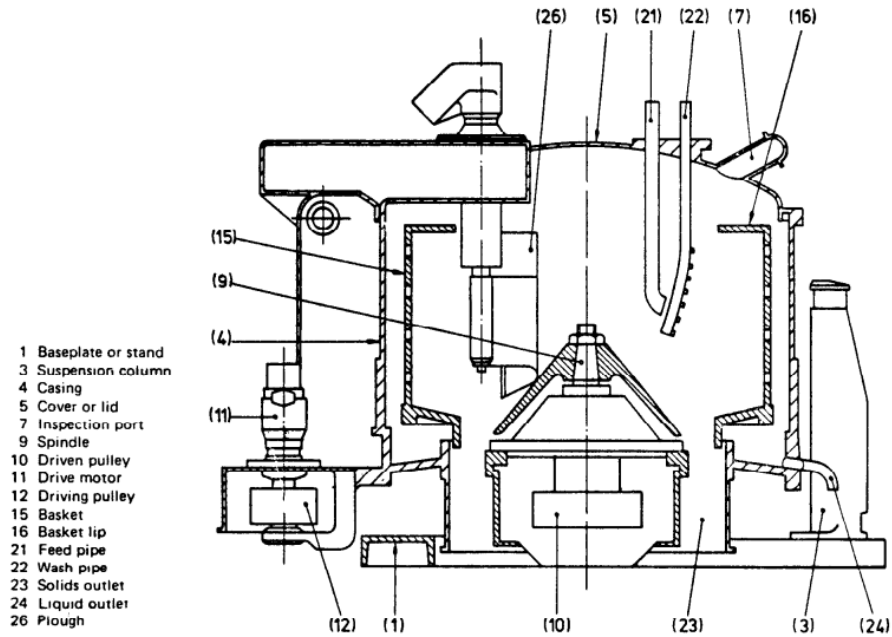

FIG. 5 THREE POINT SUSPENSION, AUTOMATIC DISCHARGE, BATCH CENTRIFUGE, FILTRATION MACHINE

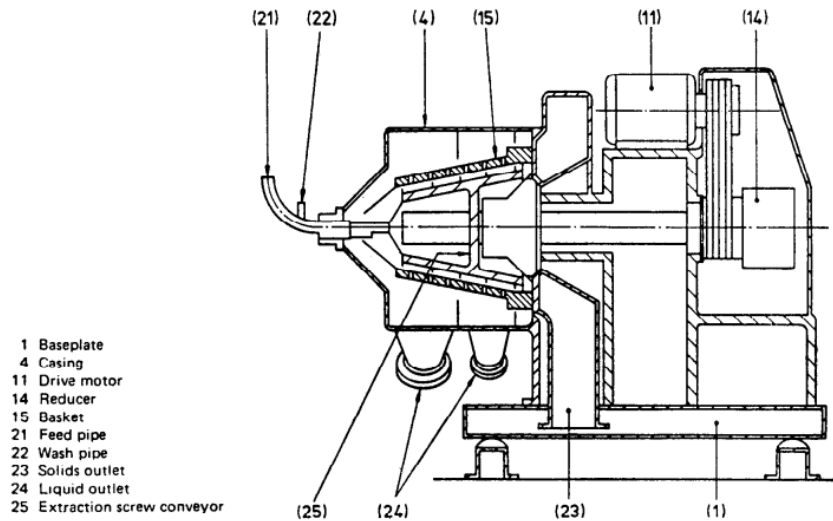

FIG. 6 BASKET CENTRIFUGE WITH EXTRACTION SCREW CONVEYOR, CONTINUOUS CENTRIFUGE, FILTRATION MACHINE

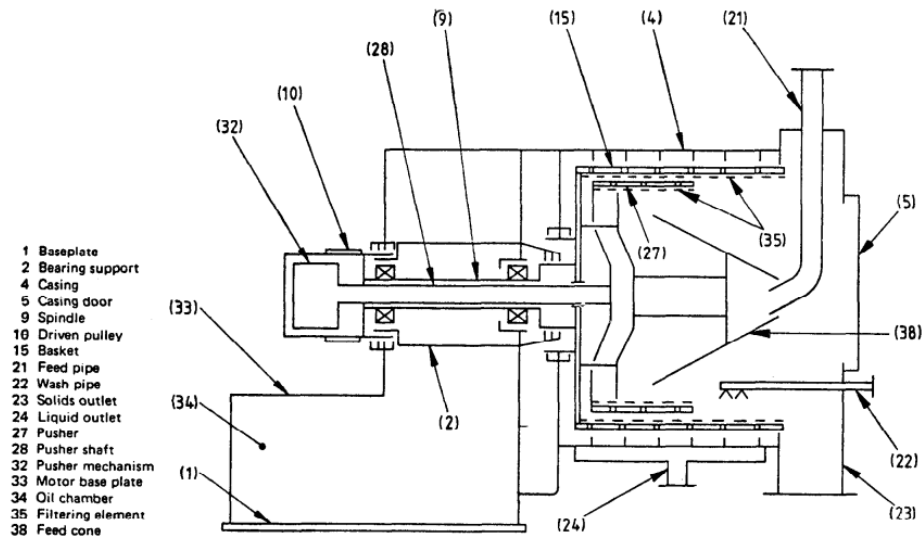

FIG. 7 PUSHER, CONTINUOUS CENTRIFUGE, FILTRATION MACHINE

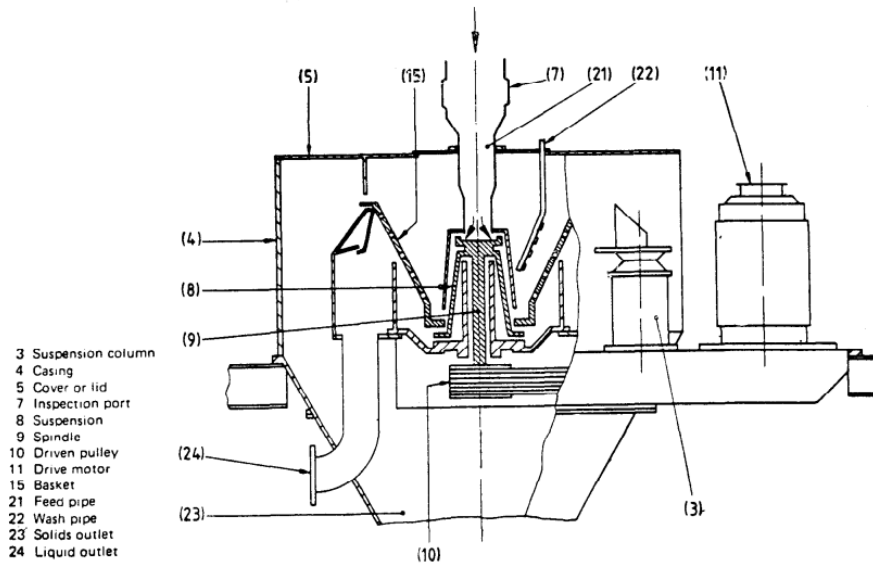

FIG. 8 SELF DISCHARGE CONICAL, CONTINUOUS CENTRIFUGE, FILTRATION MACHINE

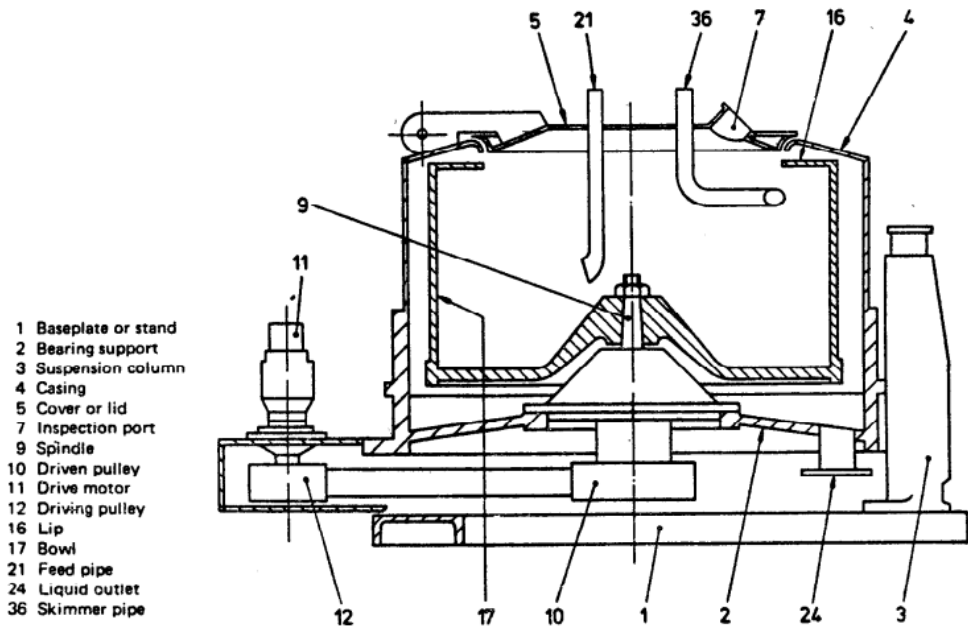

FIG. 9 THREE POINT SUSPENSION, BATCH CENTRIFUGE, SEDIMENTATION MACHINE

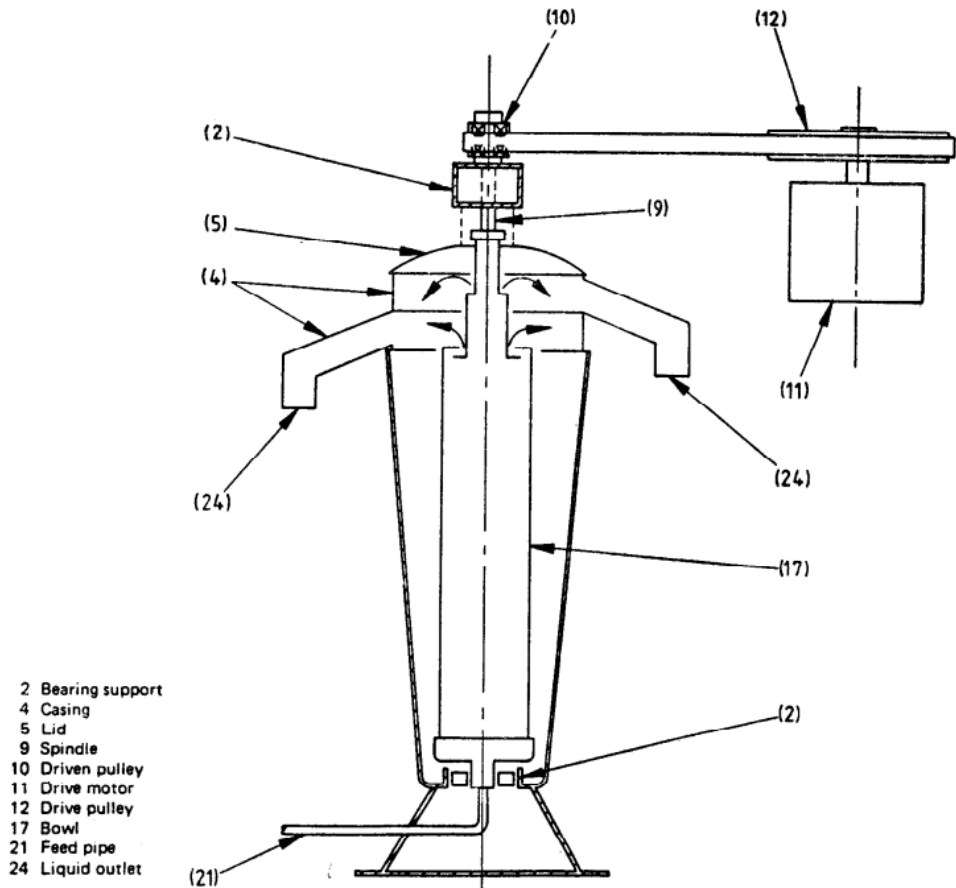

FIG. 10 TUBULAR BOWL, BATCH CENTRIFUGE, SEDIMENTATION MACHINE

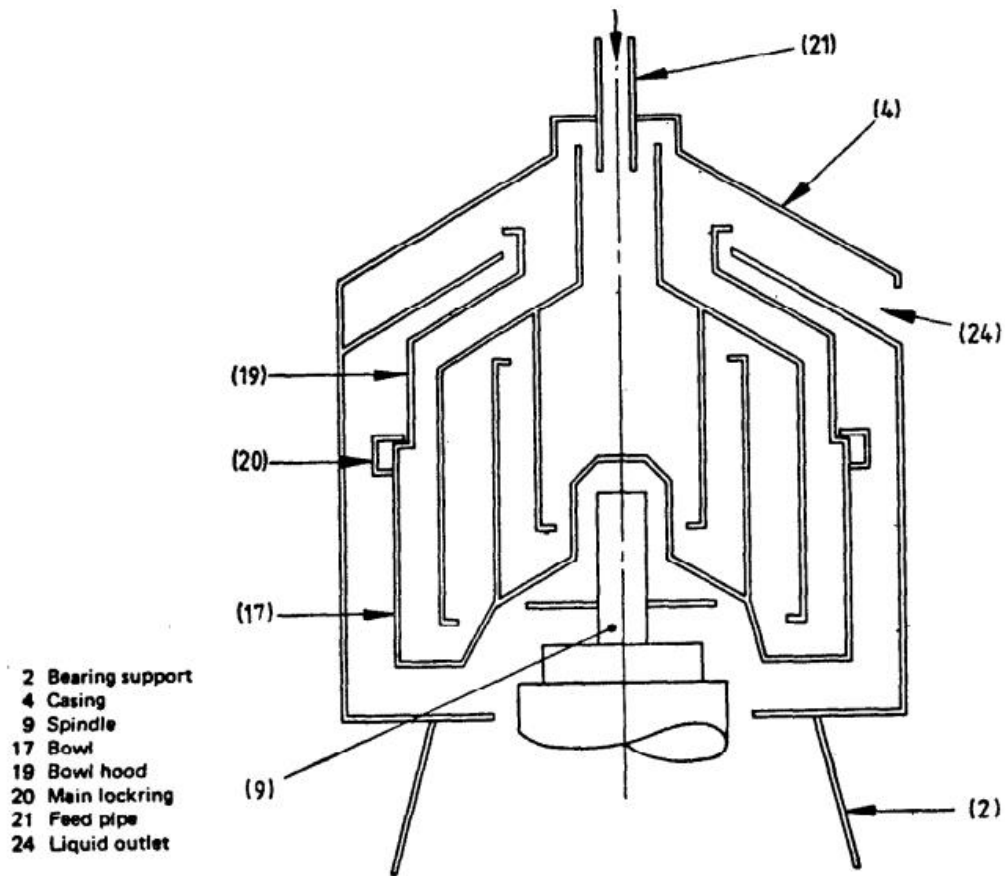

FIG. 11 CHAMBER BOWL, BATCH CENTRIFUGE, SEDIMENTATION MACHINE

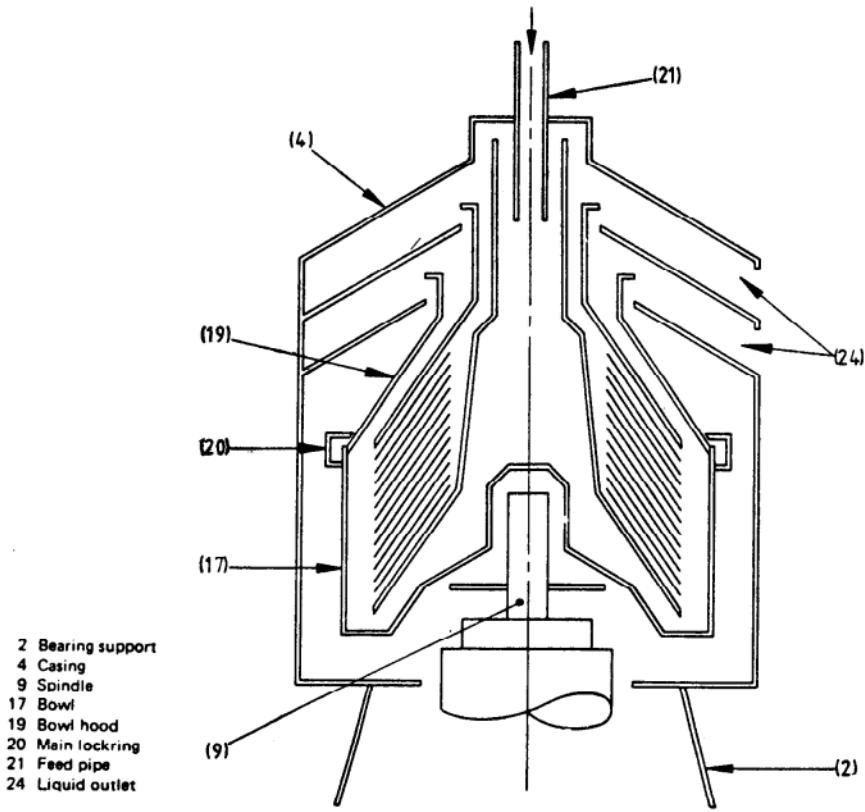

FIG. 12 DISC BOWL, BATCH CENTRIFUGE, SEDIMENTATION MACHINE

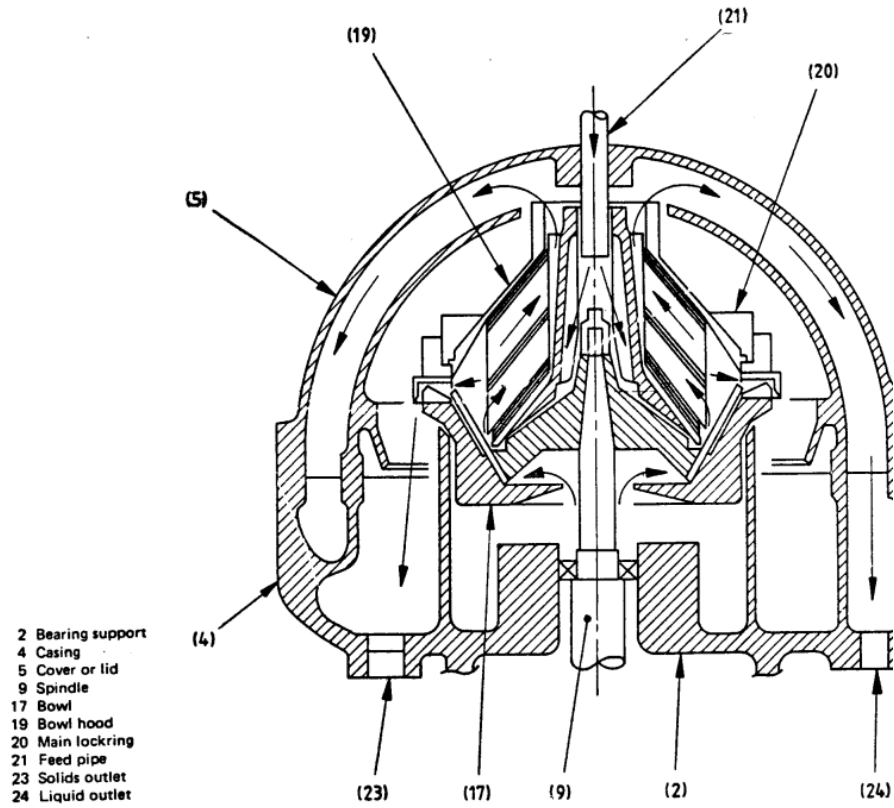

FIG. 13 NOZZLE DISCHARGE DISC CONTINUOUS CENTRIFUGE, SEDIMENTATION MACHINE

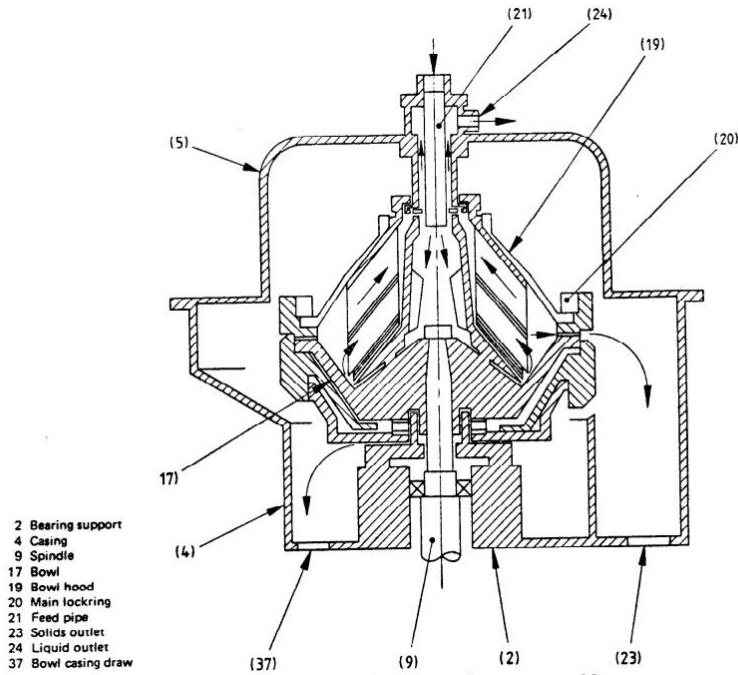

FIG. 14 OPENING BOWL CONTINUOUS CENTRIFUGE, SEDIMENTATION MACHINE

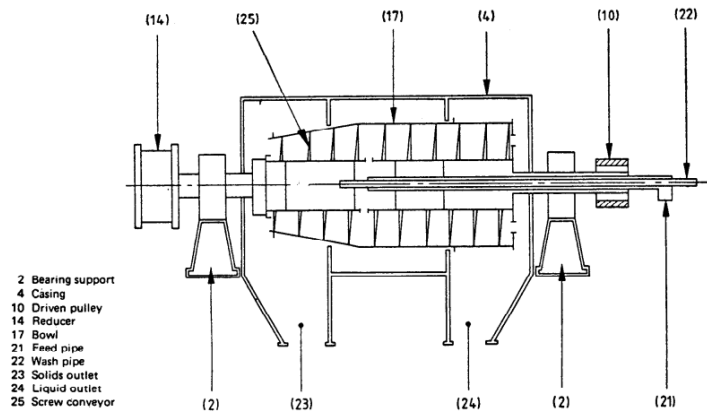

FIG. 15 SOLID BOWL DECANTER

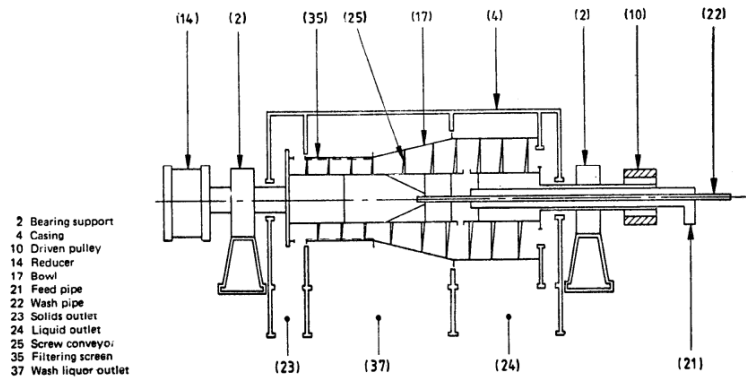

FIG. 16 COMBINED SEDIMENTATION AND FILTRATION MACHINE, SCREEN BOWL DECANTER

ANNEX B
(Clause 4.3.1)

PROTECTIVE LINING MATERIALS AND SURFACE COVERING

B-1 The conditions for which linings have to be considered fall into the following four basic categories:

- a) To protect the centrifuge parts from corrosive attack by the substances handled;
- b) To protect the product from contamination by the centrifuge materials;
- c) To protect the centrifuge parts from damage by abrasion, erosion, scuffing, seizing, wear, etc;
- d) To prevent the generation of sparks.

The first of these categories is the more common. However, the severity of the corrosive effect of products varies widely and this has a bearing on the minimum qualities required of the lining.

B-2 The choice of the protective lining should be governed by its compatibility with the substances handled, by its adhesive bond to the parent material (particularly on baskets and bowls) and by its resistance to erosion/ abrasion and mechanical damage.

B-3 The manufacturer and the user should agree the lining material to be used, the standard to which it shall be applied and the inspection to be carried out. The edges of perforations are particularly vulnerable and it is essential that the choice of lining materials and application method take this into account. Similarly, careful arrangements should be made at edges and other discontinuities (for example, basket lip).

B-4 Further guidance on the lining of vessels and equipment is given in IS 4682 (Parts 1 to 10).

ANNEX C
(Clause 6.1)

METHODS OF STRESS ANALYSIS FOR CYLINDRICAL BASKETS OR BOWLS

C-I SYMBOLS AND ABBREVIATIONS

The following symbols are used (see figures 17 and 18).:

b_1, b_2	is the centre distance between adjacent perforations	(in mm)
d	is the diameter of perforations	(in mm)
M	is the maximum load at the permissible angular velocity	(in kg)
h	is the internal axial length of basket or bowl	(in mm)
k	is the lowest of coefficients k_1, k_2, k_3, k_4 and k_5	--
k_1	is the weld coefficient applicable to joints not subjected to inspection and testing	--
k_2	is the weld coefficient applicable to joints subjected to approved inspection and testing	--
k_3, k_4	are the stress coefficient	--
k_5	due to perforations	--
n	is the number of circumferential rows of perforations	--
q	is the coefficient of reduction of the apparent density due to perforations	--
r_1	is the internal radius of shell	(in mm)
r_2	is the arithmetic mean radius of shell	(in mm)
r_3	is the internal radius of load	(in mm)
S	is the shell thickness	(in mm)
z	is the reinforcing ring (hoop) coefficient	--
a	is the angle between staggered perforations	(in degrees)
p_1	is the density of material of construction of shell	(in kg/dm ³)
p_2	is the density of wet cake (or load) at the permissible angular velocity	(in kg/dm ³)
f_1	is the tensile stress in shell due to unloaded drum rotation	(in N/mm ²)
f_2	is the tensile shell stress due to centrifugal force acting on a homogeneous load	(in N/mm ²)
f_3	is the tensile shell stress due to centrifugal force acting on a non-homogeneous (for example, textile) load	(in N/mm ²)
f_t	is the sum of tensile stresses acting on the shell	(in N/mm ²)
f_R	is the ultimate tensile strength	(in N/mm ²)
f_Y	is the yield point stress for steels with marked yield point, or 0.2% proof stress for steels without marked yield points, or 1.0% proof stress for austenitic steels	(in N/mm ²)
ω	is the permissible angular velocity	(in rad/s)

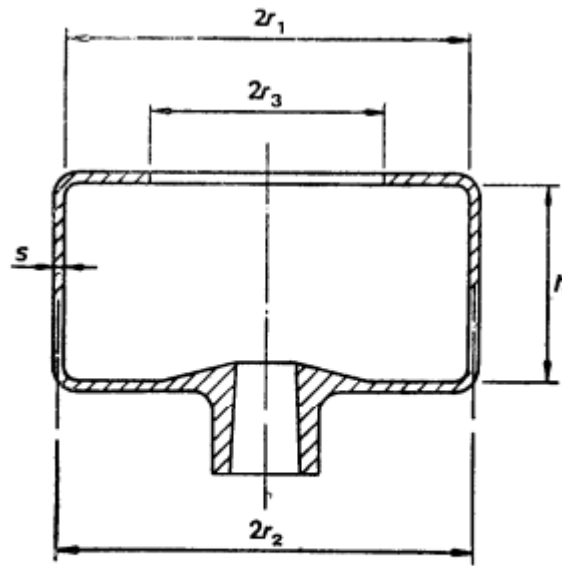

NOTE — This sketch is diagrammatic only and does not purport to show a standard form of basket construction.

FIG. 17 TYPICAL BASKET

C-2 SHELL STRESSES OF ROTATING BASKET OR BOWL

C-2.1 Circumferential stress

The circumferential stress (f_1) shall be determined by the following equation.

$$f_1 = Q\rho_1\omega^2r_2^2 \times 10^{-9}$$

The coefficient q (see C-3.3) has been used to compensate for reduction in density due to perforations.

C-2.2 Stress Due to Centrifugal Force Exerted by Load

If the basket or bowl has a lining (for example, gauze, filter cloth), the load shall be increased by the mass of such lining. a)

- a) The tensile stress due to centrifugal force acting on a homogeneous mass loading (f_2)(for example, liquids, fluid slurries where the load density is known) shall be determined by the following equation.

$$f_2 = \rho_2\omega^2 \frac{(r_1^2 - r_3^2)r_1}{10^{-9} \times 2zs}$$

- b) The tensile stress due to centrifugal force acting on a non-homogeneous load (f_3) (for example, textiles, furs where the load mass is known) shall be determined by the following equation.

$$f_3 = \frac{\omega^2 M}{10^3 \times 3\pi hs} \left(\frac{r_1^3 - r_3^3}{r_1^2 - r_3^2} \right)$$

C-2.3 Stress Summation

C-2.3.1 Homogeneous Mass Loading

The sum of tensile stresses acting on the shell (f_t) for homogeneous mass loading shall be determined using the following equation.

$$f_t = \frac{f_1 + f_2}{k}$$

Where the load density is known, the sum of tensile stresses acting on the shell (f_t) for homogeneous mass loading shall be determined using the following equation.

$$f_t = \frac{\omega^2}{10^9 \times k} \left[(q\rho_1 r_2^2 + \rho_2) \frac{(r_1^2 - r_3^2) (r_1)}{2zs} \right]$$

Where the load mass is known the sum of tensile stresses acting on the shell (f_t) for homogeneous mass loading shall be determined using the following equation.

$$f_t = \frac{\omega^2}{10^9 \times k} \left(q\rho_1 r_2^2 + \frac{10^6 \times Mr_1}{2\pi hzs} \right)$$

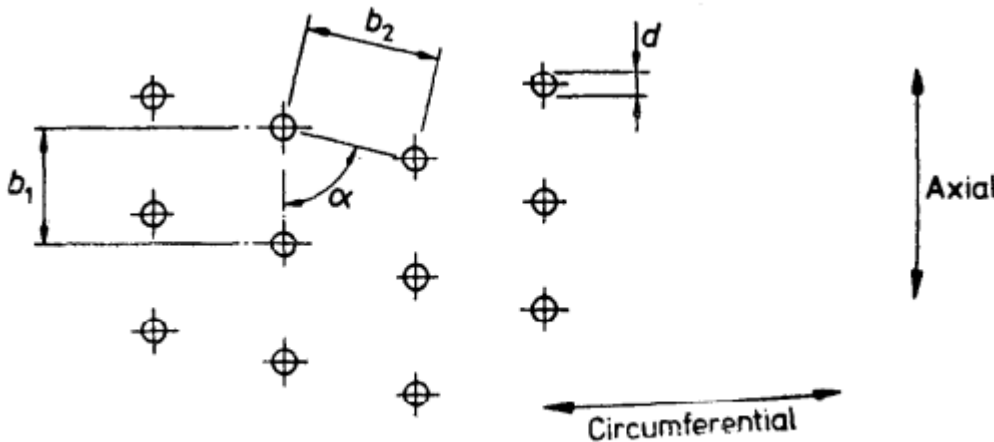

FIG. 18 PATTERN OF PERFORATIONS

C-2.3.2 Non-homogeneous Load

The sum of tensile stresses acting on the shell (f_t) for a non-homogeneous load shall be determined using the following equation.

$$f_t = \frac{(f_1 + f_3)}{k}$$

Where the load mass is known the sum of tensile stresses acting on the shell (f_t) for a non-homogeneous load shall be determined using the following equation.

$$f_t = \frac{\omega^2}{10^9 \times k} q \rho_1 r_2^2 + \frac{10^6 \times M}{3\pi n z s} \left(\frac{r_1^3 - r_3^3}{r_1^2 - r_3^2} \right)$$

C-3 COEFFICIENTS

C-3.1 Reinforcing Hoop Allowance

If hoops are used to reinforce the basket shell, the effect shall be allowed for by the use of the coefficient z. This coefficient shall be determined from stress calculations using methods applicable to such a configuration.

NOTE - z = 1 if no hoops are fitted z > 1 when hoops are fitted.

C-3.2 Coefficients for Welded Joints and Perforations

C-3.2.1 General

The coefficient k to be used in the stress calculation of **C-2.2** is the smallest value obtained from the coefficients k_1, k_2, k_3, k_4, k_5 , as given in **C-3.2.2** and **C-3.2.3**.

C-3.2.2 Welded Joint Coefficient

Provided that the mechanical properties of the weld match those of the material used in the construction of the shell, the following coefficients shall be used to allow for the reduction in strength at the welded joint.

- a) Welded joints not subjected to inspection or testing $k_1 = 0.8$
- b) Welded joints subjected to 100% radiographic examination or other recognized methods of inspection $k_2 = 0.95$

C-3.2.3 Perforation Coefficient

In case of uniformly distributed perforations, the smaller of the following values of k shall be used (*see* Figure 18):

$$k_3 = \frac{b_1 - d}{b_1} \text{ or } k_4 = v \frac{(b_2 - d)}{b_2}$$

$$v = \frac{1 + \tan^2 \alpha}{\sqrt{(1 + 3 \tan^2 \alpha)}}$$

The value v is dependent on angle α , where $\alpha < 90^\circ$

If the inclined centreline distance b_2 and the angle α are different, depending on what is taken as the axial position, then k_4 shall be calculated for both values of b_2 and α . The smaller value of k_4 is to be used.

In baskets with a single row of perforations close to the bottom and/or to the top, the following value of k shall be used:

$$k_5 = 1 - \frac{nd}{h}$$

NOTE - No perforations should be made within 9 mm of the weld material but if this is unavoidable, the smallest of the coefficients k_3 , k_4 , k_5 shall be multiplied by the appropriate welded joint coefficient.

C-3.3 coefficient for the reduction in the apparent density of the shell due to perforations. The coefficient for the reduction in the apparent density of the shell due to perforations shall be determined using the following equation.

$$q = 1 - \frac{\pi d^2}{4b_1 b_2 \sin \alpha}$$

C-4 ABNORMAL LOAD DUTY

Should the duty for which the basket is used involve abnormal load distribution, for example, a heavy load concentration in a small area of the basket, the basket will require to be of greater strength than the above equations imply.

ANNEX D
(Clause 10.0)
FLAMMABLE MATERIALS

D-1 FIRE AND EXPLOSION CONDITIONS

D-1.1 For a fire or explosion to occur within a centrifuge system, there has to be a combination of the following three factors:

- a) flammable gas or vapour present in sufficient concentration (between the lower and upper explosive limits);
- b) oxygen present in sufficient concentration usually above 10 vol. %);
- c) a source of ignition.

D-1.2 At a temperature above the flash point a flammable condition is likely to occur. Sources of ignition within a centrifuge may be hot spots caused by mechanical friction or the discharge of static electricity. At a sufficiently high temperature auto-ignition of a hydrocarbon could occur.

D-2 LEVELS OF RISK

Three broad levels of risk are defined as follows.

- a) High-A high level of risk exists where a flammable atmosphere is likely to occur in normal operation and where machines are opened to the atmosphere on a regular basis for product discharge.
- b) Moderate-A moderate level of risk exists:
 - 1) where a flammable atmosphere is likely to occur in normal operation and where machines are provided either with bolted covers or with interlocks to prevent covers being opened while the machine is in motion, or
 - 2) where any duty known by experience to give rise to the possibility of metal to metal contact including metallic debris in the feed and either operating close to or above the flash point or when a flammable atmosphere could occur under predictable abnormal circumstances.
- c) Low-A low level of risk exists where a flammable atmosphere is unlikely to occur.

ANNEX E
(*Clause 12.2*)

RECOMMENDATIONS FOR PERIODIC EXAMINATION AND TESTING

E-1 The user should, in consultation with the manufacturer, define the examination period based on the process parameters.

The interval between examinations should not exceed 12 months and should be carried out by a person with sufficient practical and theoretical knowledge and actual experience of the type of machinery to be examined. Such persons have to be able to examine the machine in all of the ways stipulated in order to detect faults and weaknesses and assess their importance in relation to safe operation of the machinery. The results of examinations are to be recorded by the examiners and then countersigned and filed by the user.

Particular care should be taken in the examination of perforations, at changes of section and other areas of high stress and those parts used to attach the basket or bowl to the spindle.

It shall be shown that shell thickness and other important dimensions are within the allowable Values given by the manufacturer (*see Annex F*)

On completion of examination, the tests referred to in **12.1.3** shall be carried out.

E-2 An examination and testing of the items listed in (a) to (c) should be carried out.

a) The basket or bowl should be examined and tested for:

- 1) general condition;
- 2) mechanical erosion and corrosion damage, shell thickness;
- 3) condition of welds; and
- 4) conditions of linings where applicable

d) The controls and interlocks should be examined and tested for :

- 1) correct functioning;
- 2) wear of mechanical parts; and
- 3) braking and emergency stop.

c) The foundation and principal fasteners should be examined and tested for :

- 1) corrosion, wear and security of fasteners relating to basket/bowl, bearings, machine mountings and suspension; and
- 2) corrosion and soundness of foundation.

E-3 No modification of repair such as welding which may impair mechanical properties should be carried out on the highly stressed parts of a centrifuge without prior consultation with the manufacturer.

ANNEX F
(Clause 13)

INFORMATION

F-1 INFORMATION TO BE SUPPLIED WITH ENQUIRY OR ORDER

The information listed in **F-1.1** to **F-1.6** shall be supplied with an enquiry or order.

F-1.1 General

The following information shall be given :

- a) details of materials to be handled;
- b) purpose or duty;
- c) continuous or batch operation, automatic or non-automatic;
- d) toxicity, and other known health risks;
- e) flammability;
- f) corrosive properties; and
- g) abrasion/erosion properties

F-1.2 Type of Machine

The type of machine preferred shall be stated (for example, decanter, pusher, etc.)

F-1.3 Machine Requirements

The following information shall be given:

- a) materials of construction;
- b) internal pressure;
- c) inert gas blanket requirement;
- d) zone classification;
- e) available services:
 - 1) electrical: full details of supply; voltage (in V); number of phases; number of wires; and frequency (in Hz);
 - 2) air pressure (in N/mm³);
 - 3) cooling water pressure (in N/mm²); temperature (in °C);
 - 4) inert gas : type and pressure (in N/mm²);
 - 5) others;
- f) feed system (preceding unit operation);
- g) discharge system of each phase (succeeding unit operation); and
- h) washing: liquor and rate.

F-1.4 Process Information

The inputs and outputs of the machine shall be stated separately in the following details where appropriate :

- a) mass flow rate;
- b) specific gravities of liquors and particulate solids;
- c) volume flow rate;
- d) pressure;
- e) temperature;
- f) viscosity;
- g) pH value;
- h) particle size (distribution) and shape; and
- j) maximum density of feed and of its constituents.

F-1.5 Process Tolerances

The following process tolerances shall be given:

- a) percentage of retained liquor in solids; and
- b) percentage of solids in centrifuged liquors.

F-1.6 Purchaser's Special Requirements

Any special requirements specific to the purchaser's needs shall be supplied with an enquiry or order : examples of such requirements are as follows :

- a) out of balance monitors;
- b) inert gas system;
- c) inspection and testing; and
- d) noise.

F-2 INFORMATION TO BE SUPPLIED WITH TENDER

The information listed in **F-2.1** to **F-2.4** shall be supplied with a tender.

F-2.1 Machine Offered

The manufacturer shall provide full details of the machine which is offered, including the following information:

- a) machine type and size;
- b) installed and full load power requirements and operating speeds of all drives;
- c) weight; and
- d) installation specification.

F-2.2 Materials of Construction

The manufacturer shall provide details of the materials used in the construction of the following:

- a) basket or bowl;
- b) plough or conveyor;
- c) casing;
- d) spindle;

- e) seals;
- f) filter elements; and
- g) bearings.

F-2.3 Ancillaries

The manufacturer shall provide details of the following ancillaries:

- a) interlocks and other safety equipment;
- b) lubrication system details;
- c) seal system details;
- d) flocculant dosage system;
- e) controls and instrumentation; and
- f) sampling arrangements.

F-2.4 Performance

The manufacturer shall provide details of expected performance related to the required machine duty, including the following where applicable and shall state if this performance is guaranteed:

- a) percentage of retained liquor in solids;
- b) percentage of solids in centrifuged liquors;
- c) cycle times;
- d) noise level; and
- e) power consumption.

F-3 INFORMATION TO BE SUPPLIED AFTER ORDER

The information listed in **F-3.1** to **F-3.3** shall be supplied to enable the user to install, operate and maintain the unit effectively and safely:

F-3.1 Installation

The following installation details shall be supplied:

- a) general arrangement drawings;
- b) civil engineering requirements in accordance with **6.11**;
- c) electrical requirements;
- d) circuit and control diagrams;
- e) assembly and erection instructions;
- f) drive details; and
- g) heaviest lift for assembly/maintenance.

To enable the user to operate the machine the following shall be supplied;

- a) data sheet;
- b) operating manual;
- c) interlocks and safety procedures;
- d) testing instructions; and

e) commissioning instructions.

F-3.3 Maintenance

To enable the operator to maintain the machine the following shall be supplied:

- a) maintenance schedule;
- b) inspection schedule;
- c) lubrication schedule;
- d) dismantling and assembly instructions;
- e) special tools;
- f) fault finding charts;
- g) servicing facilities;
- h) parts list/detailed drawings including details of allowable dimension;
- j) schedule of accessories and ancillaries; and
- k) recommended spares.