

**BUREAU OF INDIAN STANDARDS**

**DRAFT FOR COMMENTS ONLY**

*(Not to be reproduced without the permission of BIS or used as an Indian Standard)*

**DRAFT AMENDMENT NO. 2**

**TO**

**IS 16988: 2018 COMPRESSED NATURAL GAS CYLINDER VALVE INTEGRATED  
WITH SOLENOID OPERATION (REMOTELY CONTROLLED) FOR  
AUTOMOTIVE USE — SPECIFICATION**

ICS 23.020.35; 23.060.40; 43.060.40; 75.060

---

Gas Cylinders Sectional  
Committee, MED 16

Last date for receipt of  
comments is **26 July 2024**

---

*(Page 5, clause 7.2.1)* — Substitute the following for existing:

‘Where the pressure relief device is a bursting disc fitted to the valves of CNG cylinders, the maximum bursting pressure shall not exceed the 110 percent of test pressure of the cylinder and shall be more than the developed pressure of gas at 65 °C. The rated bursting pressure shall meet the requirement as mentioned above and same shall be specified in drawing. The actual burst pressure of the disc shall not be in excess of its rated burst pressure and not less than 90 percent of its rated burst pressure.’

*(Page 13, clause 9.1.1, Note)* — Add the following Note at the end and number the subsequent Note accordingly.

‘Outlet Connection for CNG Valves shall be subjected to agreement between the purchaser and the manufacturer’

*(Page 14, Outlet No. 21A)* — Substitute the following figure for the existing as appropriate.

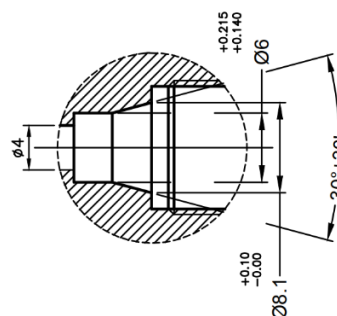

ENLARGED VIEW OF X

*(Page 16, clause 10, sixth para)* — Add the following after point (m).

‘(n) Changes of the O-ring material of a valve parallel inlet connection (repetition of impact test).’

(Page 23, clause **11.1.5**) — Delete clause and its sub clause.

(Page 24, clause **11.1.7**, first para) — Delete ‘and condensate corrosion resistance test (see **11.1.5**)’.

(Page 24, clause **11.1.8.2.3**) — Delete ‘and condensate corrosion resistance test (see **11.1.5**)’.

(Page 24, clause **11.1.8.3.2**) — Delete ‘and condensate corrosion resistance test (see **11.1.5**)’.

(Page 24, clause **11.1.8.4.2**) — Delete ‘and condensate corrosion resistance test (see **11.1.5**)’.