

For BIS Use Only

Draft for Comments

Draft Indian Standard

**GAS CYLINDERS — WELDED LOW CARBON STEEL CONTAINERS EXCEEDING
250 LITRES AND UP TO 1000 LITRES WATER CAPACITY FOR THE TRANSPORT
OF LPG — DESIGN AND CONSTRUCTION**

ICS 23.20.30

**Not to be reproduced without the permission
of BIS or used as a Standard**

**Last date for receipt of
Comments is 19 July 2021**

1 SCOPE

This Indian standard specifies the minimum requirements for the material, design, fabrication, workmanship, inspection, testing, manufacture and marking of refillable welded carbon steel containers exceeding 250 litres up to 1000 litres water capacity for liquefied petroleum gases (*see* IS 4576).

2 REFERENCES

The standards given in Annex A contain provisions, which through reference in this text, constitute provisions to this standard. At the time of publication, the editions indicated were valid. All standards are subject to revision and parties to agreements based on this standard are encouraged to investigate possibility of applying the most recent editions of the standards listed in Annex A.

3 TERMINOLOGY

For the purposes of this standard, the following definitions in addition to given in IS 7241 shall apply.

3.1 Yield Strength — Stress value corresponding to the lower yield strength, ReL or, for steels that do not exhibit a defined yield point, the 0.2 percent proof strength, $R_{p0.2}$ for carbon steels and 1 percent proof strength for austenitic stainless steels, $R_{p1.0}$

3.2 Normalizing — Heat treatment in which, a container is heated to a uniform temperature above the upper critical point (AC_3) of the steel to regenerate or homogenize the metallurgical structure of the steel and then cooled in a controlled or still air atmosphere.

3.3 Stress Relieving — Heat treatment given to a container, the object of which is to reduce the residual stresses without altering the metallurgical structure of the steel, by heating to a uniform temperature below the lower critical point (AC_1) of the steel and then cooling in a controlled or still air atmosphere.

3.4 Batch — A lot of 50 finished containers of a specific type made to the same design, size, and material specifications; using the same welding procedures and heat-treated under the same conditions of temperature and duration.

3.5 Test Pressure — The internal pressure required for the hydrostatic test of the cylinders. The test pressure will be 1.5 times the saturated vapour pressure of the gas at 65°C.

3.6 Finished Container — Is a container which is fully assembled and appropriately stamped, but without any external covering

4 MATERIALS

4.1 The steel used in the manufacture of containers shall conform to IS 5986, IS 2041 or ISO 9328 Part 1 to 5.

4.2 Suitable low carbon steel other than those given in **4.1** may be used with the prior permission of the statutory authority. In such a case, the minimum specified value of yield strength guaranteed by the manufacturer for the finished container shall be used for the purpose of calculating the wall thickness of the container.

4.3 The manufacturer shall obtain and provide certificate of cast (heat) analysis of the steels supplied for the construction of the containers and establish means to identify the containers with the casts of steel from which they are made.

4.4 The bung/valve pad shall be hot forged from rolled steel bars either conforming to Class 1A or Class 2 of IS 1875 or IS 2062 or IS 2004. The bung machined from such forging shall be free from surface defects such as fissures, surface cracks, porosity, laminations, pinholes, etc (Annex B).

4.5 Compatibility of the Materials used for the Container

The materials used for the container, including welded zones, shall be compatible with the intended gas service and meet the applicable requirements of IS/ISO 11114-1, IS/ISO 11114-2, and IS/ISO 11114-4. Components (e.g. bolts and studs) in contact with the gas shall meet the applicable requirements of IS/ISO 11114-1, IS/ISO 11114-2, and IS/ISO 11114-4.

4.6 Welding Consumables

The welding consumables shall be such that they are capable of giving consistent welds with the material properties at least equal to that specified for the parent material in the finished container.

5 DESIGN

5.1 General Provisions

A fully dimensioned sectional drawing of the container, together with design calculations, guaranteed yield strength and scheme of manufacture, shall be submitted by the manufacturer to the inspecting authority for final approval by statutory authority.

5.2 Calculation of Thickness

- P_h = is the test pressure (MPa);
 Di = is the maximum internal diameter of the container (mm);
 Z = joint efficiency (0.85) with 100% radiography;
 t_c = minimum finished thickness of the cylindrical shell (mm);
 t_d = minimum finished thickness of the dish ends (mm);
 f = is the maximum allowable stress in the container (N/mm²);
It shall not exceed minimum of the following
YS/ 1.5 or TS / 3.5
 $R = Di (.44K + .02)$
 $K = 2$ for semi ellipsoidal dish end.
TS = is the minimum value of tensile strength guaranteed by the container manufacturer (N/mm²).
YS = is the minimum value of yield strength guaranteed by the container manufacturer (N/mm²).

In both the above cases TS and YS shall not be more than the value stated by the steel manufacturer

5.3 Cylindrical Wall

The minimum finished cylindrical section wall thickness (t_c), shall be not be less than the maximum value of thickness calculated using the following formula

$$t_c = \frac{P_h \times Di}{(3zf - P_h)}$$

5.4 Dish Ends

The minimum thickness of the container with semi ellipsoidal dish end shall be calculated using the following formula:

$$t_d = \frac{10P_h R}{27fz - 5P_h}$$

5.5 Compensation of Openings

Openings shall be placed on the ends and have their largest dimension, N , less than 0.5 Do (see Figure 1). The total cross-sectional area to be compensated (B) in any given plane shall not be less than:

$$B = N.S$$

Where :

S = is the thickness of an un-pierced dished end section calculated
 N = is the largest dimension of the opening.

In calculating the area of compensation, only material up to a distance, P (*surface distance*), from the actual surface of the shell can be considered, where:

$$P = \sqrt{(N \times t_e)}$$

Where :

P = is the maximum dimension of pads that can be considered as compensation;
 N = is the largest dimension of the opening;
 T_e = is the thickness of un-pierced end in location of an opening.

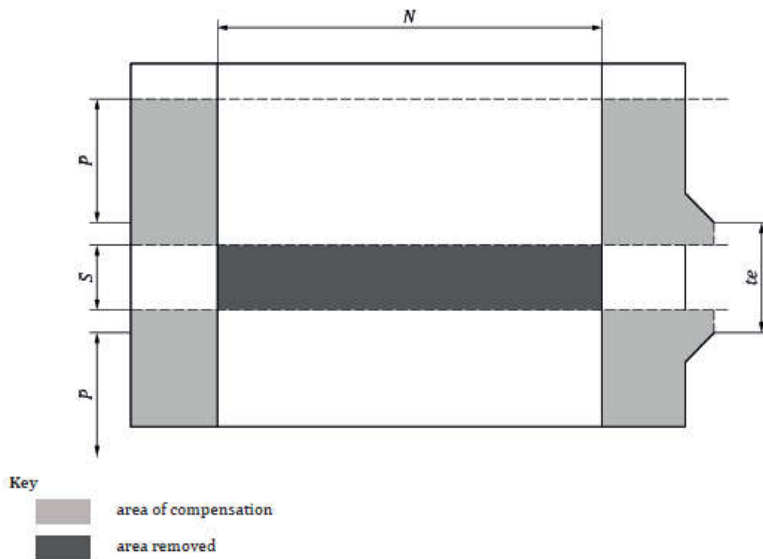

Figure 4 — Opening compensation

6 FITTINGS

The mandatory fittings for containers defined in this standard shall include Valves with EFCV and Pressure Relief Devices. The other optional fittings shall be Level Gauge, Drain Plug or any other fitting as approved by Statutory Authority.

While there is no restriction on the number of apertures, their number shall be kept to the minimum consistent with safe operation. Openings for the fittings shall be located only in the dished ends.

For opening greater than 15 mm, the fittings shall be attached to parts of the container that are locally reinforced by a pad, or to a flange or access plate of adequate thickness bolted to a flange. The reinforcement shall be provided as defined in this standard.

6.1 Screwed Fittings

Fittings up to 80 mm thread diameter can be screwed. If a tapered thread is used with sealing of the pressure on the threads, then a sealant (e.g. PTFE tape, PTFE dispersion, a lead ferrule or an aluminium ferrule) shall be inserted between the threaded components to effect a seal. Threads should be tapped to gauge, clean cut, even, and without cracks. Any thread standards acceptable to the competent authority can be used.

6.2 Bolted Connections

Bolted connections shall be made with at least three bolts/studs. Studs shall be threaded to their ends. Joining surfaces shall be flat and true in accordance with the flatness, parallelism, and perpendicularity tolerances specified on the design drawings.

6.3 Valve

The cylinders shall be equipped with valve as per IS 16484 or EN 13175 for combo valve or equivalent IS standard for combo valve. Liquid withdrawal shall be equipped with EFCV.

6.4 Pressure Relief Valve

Pressure Relief valve shall conform to EN 13953 or equivalent IS standard. The pressure relief valve shall be equipped with an isolation system for facilitating periodic maintenance and inspection. Periodic inspection shall be carried out once in a year. The periodic inspection shall be conducted to verify the set pressure, reset pressure, pop up action and discharge rate at full flow as defined by the manufacturer.

6.5 Drain Plug

Drain plug if provided shall have tapered thread as mentioned in clause **6.1** .

7 PROTECTION OF FITTINGS

Containers shall be such that all fittings are protected and are situated inside the contour of the end shrouds or support structure.

7.1 Fitting Protection at Shroud

The top of the shroud shall be higher than the top of the valve protective cap so as to prevent damage occurring to the valve/connector if the container is dropped or hit.

In addition to the general protection, fittings shall be provided with local protection for dust and moisture ingress. Pressure Relief Valves shall not be obstructed and do not require additional protection.

7.2 Fitting Protection for Container Bottom

Containers designed to be carried in their vertical position shall have a frame structure. Bottom outlets and their external pipe work shall be protected from impact.

8 LIFTING ATTACHMENTS

Containers shall have structural steel members of minimum thickness 5 mm to take the forks of a fork-lift inserted into the bottom structure. The configuration of the pockets/structures shall protect the container from being damaged during normal handling.

The fork apertures shall be positioned symmetrically about the container centre of gravity and their size shall be appropriate to accommodate the fork-lift / pallet truck forks which are to be used to move the container. The fork apertures shall be designed such that the container cannot accidentally disengage from the forks.

If lifting lugs are fitted to the container, they shall be designed to withstand a design load of 2 times the maximum gross weight of the container. Containers with more than one lifting eye shall be designed such that a minimum sling leg angle of 45° to the horizontal can be achieved during lifting using the lifting eyes.

Where four lifting eyes are used, their design shall be such that they are strong enough to allow the container to be lifted by only two. Where two or four lifting eyes are used, diametrically opposite lifting eyes shall be aligned with each other to allow for correct lifting using shackle pins.

9 FABRICATION

9.1 Shell Sections

The cylindrical shell shall be made from a single plate.

9.2 Dished Ends

The dished ends shall each be pressed from a single plate. All forming shall be done by stamping, rolling, or pressing machine. Local heating or hammering is not permissible.

Cold-formed dished ends shall be normalized after pressing by using a heat treatment process at a temperature recommended by the steel manufacturer.

Ends distorted during heat treatment beyond the allowable limits shall be re-aligned, and if it is done by cold deformation (e.g. in a press), a further heat treatment for stress relieving shall be done.

Hot pressed dished ends heated to above 650 °C do not require normalizing after forming.

10 WELDING

The manufacturer, before proceeding with the production of a given design shall qualify the specific welding procedures and welders to be in accordance with the requirements of IS 15326. Records of such qualification shall be kept on file by the container manufacturer for a period of at least 10 years or as required by the statutory authority.

Procedural qualification tests shall be performed in such a manner that the welds shall be representative of those made in production.

10.1 Welded Joints

Plates and heads that are being welded shall be fitted, aligned, and retained in position during the welding operation. Bars, jacks, clamps, or other appropriate devices, including tack welds, can be used to hold in alignment the edges to be welded.

The welding of the longitudinal and circumferential seams shall be by an automatic or a semi-automatic process. The longitudinal weld, of which there shall be no more than one in a cylindrical section, shall be a full penetration butt weld, and any backing bars shall be removed after welding. The weld bead reinforcement shall have a gradual transition from its maximum allowable crown to the plane of the base metal surface.

The circumferential welds shall be a butt weld or joggle joint weld. In case of butt weld, backing strip shall be used for the circumferential welds.

11 SURFACE FINISH OF MATERIAL

The internal surface finish shall be specified and take account of the intended service of the container. Any scale or corrosion shall be removed using an appropriate method (e.g. shot blasting). Any surface defects (e.g. pits, scrapes, rolled-in scale or press marks), shall be ground out so that the reduced thickness is blended into the rest of the plate at an angle not less than 1:20.

The depth of any defects shall be limited to 1.5 mm. The thickness at all such locations shall be measured and proved to be greater than the minimum specified.

For carbon steel containers, before painting the finish of the external surface shall be specified SA 2.5.

Paint and/or Primer may be used as per agreement between the manufacturer and the purchaser with approval of Statutory Authority.

12 ASSEMBLY

12.1 Temporary Attachments

Any attachments (e.g. tacking strips and cleats) temporarily welded to the container to facilitate manufacture shall be of the same material as the container and shall be completely and carefully removed so as not to damage the container. Any surface imperfections remaining after removal shall be made good by repair welding.

The repaired areas shall be dressed to a smooth finish level with the surface of the adjacent parent material and be subjected to a check for surface cracks using an appropriate non-destructive testing (e.g. dye penetrant test in accordance or a magnetic particle examination).

12.2 Alignment of Joints

The plate edges at all butt seams shall not be out of alignment by more than the limits specified in ISO 5817 level C.

Where joggle joints are used, the fit of the mating parts shall be such that there is no gap greater than 0.5 mm before welding. When a joggling operation is performed on a cylindrical section, those lengths of weld that are deformed by the joggle shall be ground flush with the parent plate before the joggling operation and shall be crack detected before welding them into circumferential seams.

12.3 Attachments and Fittings

Any external attachments (e.g. shrouds or skirts) shall fit the contour of the part of the container. Any local gaps shall not exceed 2.5 mm and any change in the gap shall be gradual.

Attachments to the pressure envelope (e.g. shrouds and skirts) shall have all their welds visually inspected and 100 percent of their welds using non-destructive test (e.g. dye penetrant test in accordance with IS 3658 or a magnetic particle examination in accordance with IS 7743) prior to fitting to the pressure container.

If any defects are detected by the non-destructive test used, then all the attachment welds shall be inspected using the same non-destructive test method chosen after rectification.

13 WELD DEFECT REPAIRS

13.1 Unacceptable defects found during the manufacturing process shall be removed and re-examined to ensure complete removal.

13.2 Defects shall be repaired (e.g. by chipping, grinding, or machining out to sound metal) and re-welded. Whenever a defect is removed by grinding or machining and subsequent repair by welding is not required, the excavated area shall be blended into the surrounding surface so as to avoid sharp notches, crevices, or corners. Care shall be taken to ensure proper weld penetration and complete fusion of the fresh weld deposit with the plates and previously deposited weld metal.

13.3 Flame gouging could be used as an alternative method for cutting out defects provided the edges are subsequently machined or ground back to sound material.

13.4 Where welding is required after removal of a defect, the area shall be cleaned and welding performed using the same processes and qualified welders that are employed in the manufacture of the pressure container.

13.5 After a defect has been removed, and prior to making weld repairs, the area shall be examined by suitable methods as specified in this standard to ensure that the imperfection has been eliminated. After repair have been made, the repaired area shall be blended into the surrounding surface so as to avoid sharp notches, crevices, or corners, and re-examined using the same non-destructive examination method that failed the initial repair, and by all other methods of examination that were required for the affected area. After all repairs have been completed, it shall be ensured that the remaining thickness of the container meets the minimum design wall and head thicknesses.

13.6 After any rectification, 100 percent radiography shall be conducted for circumferential and longitudinal welds in addition to the non-destructive tests mentioned above.

14 CONSTRUCTION AND WORKMANSHIP

14.1 Thickness Measurement

To ensure maintenance of the minimum thickness as specified in the drawing, each finished container shall be checked ultrasonically on a grid basis at a minimum side size 500 mm (at dish end where thickness is affected by any procedure). The measurements will be made with a precision of 1/10 mm.

14.2 Out of Roundness

The out-of-roundness of the cylindrical shell shall be limited so that the difference between the maximum and the minimum outside diameter in the same cross-section is not more than 1 percent of the mean of these diameters.

14.3 Straightness

The maximum deviation of the cylindrical part of the shell from a straight line shall not exceed 0.3 percent of the cylindrical length.

15 TESTING AND EXAMINATION

15.1 Test Plates

Test plates for mechanical tests shall be provided on 1 container in every 50 containers manufactured, except that for the first 40 containers of a new design, test plates shall be tested for 1 in every 10 containers.

If different welding materials or different welding processes are used on the manufacturing of the batch, test plates as specified above shall be provided for each of them.

15.2 Provision of Welded Test Plates

- a) Test plates shall be provided at the end of a longitudinal seam.
- b) The combined length of weld in each set of test plates shall be sufficient to provide material for the tests required together with any re-tests which might be necessary with suitable allowance for discards and cutting.
- c) The material used for the test plates shall be from the same cast or to the same specification as the shell plates of the container and shall be of the same thickness as that of the shell plates represented. The test plates shall be attached at the end of the longitudinal seam in order to be welded at the same time as the longitudinal weld of the container and shall be suitably clamped or reinforced to prevent excessive distortion or warping. Alternatively, test plates can be made by making an overlong cylindrical section and cutting off a complete ring using a process not involving excessive heat. When impact tests are required, the test plate shall be oriented the same as the cylindrical body plates with respect to mill rolling and weld directions. The test plate shall be heat treated at the same time and conditions as the container.
- d) For the bend test, the test plates welds shall be dressed smooth and flush with, but not below, the surface of the adjacent plates.
- e) Straightening of the test plates that have warped during fabrication shall be carried out cold.
- f) Test plates shall be subjected to non-destructive examination to the same standard as the main seams. If the non-destructive examination of a test plate reveals the presence of flaws, which in a main seam would normally require repair, these flaws shall be avoided in the selection of the test pieces. Repair of welded test plates shall not be permitted.

15.3 Number of Test Specimens

The number of specimens required from each set of test plates shall be in accordance with Table 2. When more than one specimen of a particular type is required, the specimens shall be taken as far apart as possible.

Table 2 Number of Test Specimens Required

| Test specimen | Plate thickness | |
|--------------------|-----------------|----------------|
| | 10 mm or less | Over 10 mm |
| Macro examination | 1 | 1 |
| Transverse tensile | 1 | 1 |
| Root bend | 1 ^b | 1 ^a |
| Face bend | 1 | - |
| Charpy | 3 | 3 |

a) for a butt joint made from only one side.
b) Not necessary in case of joggle joint.

16 MECHANICAL TESTS

16.1 Tensile Tests

Tensile testing shall be carried out as specified in IS 1608. Tensile strength shall be not less than the specified minimum value for the parent metal.

Except for stress relieved containers or if the information is already available from the material certificate, tensile specimens T1 and T2 shall be made from strips cut in accordance with the requirements of 17. The tensile specimen T3 shall be taken perpendicular to the longitudinal welded seam.

The form and dimensions of the test specimen shall be as specified in IS 3600 Part 3. The face and back of the test specimen shall not be machined, but shall represent the surface of the container as manufactured.

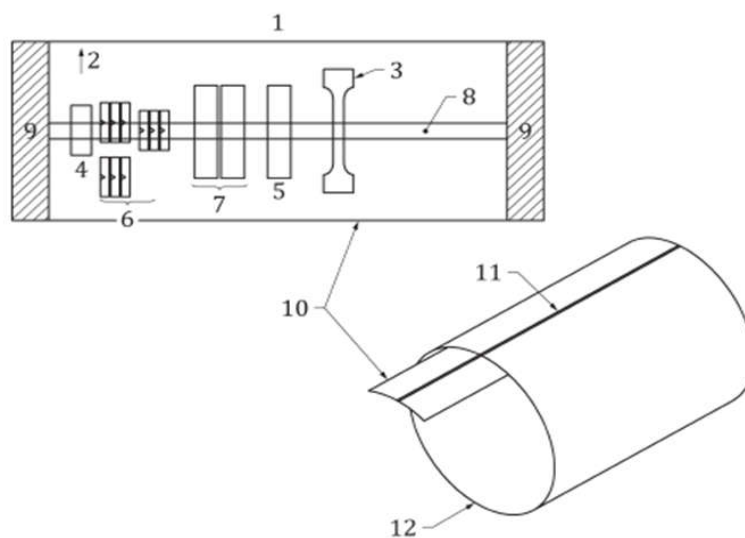

Keys

| | |
|---------------------|----------------------------|
| 1 test plate detail | 7 root bend |
| 2 rolling direction | 8 longitudinal welded seam |
| 3 tensile test | 9 discard this area |
| 4 macro | 10 test plate |
| 5 face bend test | 11 longitudinal seam |
| 6 charpy | 12 shell |

16.2 Bend Tests

Bend test specimens and the conditions and the method for carrying out the tests shall be in accordance with IS 1599.

Bend specimen with un-machined surfaces representing the outside or inside of the vessel shall only be lightly dressed so that the rolled surface of the parent metal is not wholly removed. Where the rolled surfaces of abutting plates are not level with one another, one plate can be machined at each face to a depth not exceeding 1 mm.

Bend test specimens shall be cut transversely to the welded seam. They shall be the full thickness of plates and shall have a width not less than 1.5 times the plate thickness. The edges shall be rounded to a radius not exceeding 10 percent of the thickness tested.

Two transverse bend tests shall be made. One test piece shall be tested with the surface corresponding with the outer surface of the container in tension, and the other with the surface corresponding with the inner surface of the container in tension. The diameter of the former, around which the test specimens are bent, shall not be more than three times the thickness of the test specimen, and the test is to be continued until the two limbs are parallel.

On completion of the test there shall be no visible cracks or defects at the outer surface of the specimen.

16.3 Impact Test

Except for the requirements set out in this clause, the impact test (Charpy V-notch) shall be carried out in accordance with the requirements of IS 1757.

Three impact test samples shall be taken from (see Figure):

- a) each parent material;
- b) each longitudinal weld; and
- c) one of the circumferential welds.

For the parent material samples, the transverse impact test pieces shall be taken from the wall of the container. The notch shall be perpendicular to the face of the wall. The test pieces shall be

machined only on four faces with the inner and outer face of the container remaining un-machined.

For the welds, impact test pieces that are transverse to the weld shall be taken. The notch shall be in the centre of the weld and shall be perpendicular to the face of the pressure container. The test pieces shall be machined on all six faces. If the wall thickness does not permit a final test piece width of 10 mm, the width shall be as near as practicable to the nominal thickness of the container wall.

The average of three specimens shall meet a value of 27 J/cm² for the test impact energy. No specimen shall show a value less than 70 percent of the average test impact energy value.

16.4 Macro Examination

The macroscopic examination (*see* IS 3600 -9) shall show complete fusion and shall be free of any assembly faults or an unacceptable defect.

16.5 Non-Destructive Examination of Completed Welds

Following a full external visual examination, all welded seams shall be examined by radiography/radios copy or other method as approved by Statutory Authority, if the method is proved to be as sensitive as radiography.

Personnel performing non-destructive examination shall be qualified at least to level 1 and supervised by personnel certified at least to level 2 in accordance with IS 13805. Additionally, the manufacturer shall put in force a welding quality system (e.g. as described in IS 15326-2) duly certified by inspection agency authorized by statutory authority.

16.6 Radiography/Radioscopy

All weld shall be radio graphed. Radiographs shall be taken of the entire length of each weld seam, together with the seams in the corresponding test plates. Sufficient overlap shall be ensured to cover the whole of the welded seam. The welds shall be radio graphed in accordance with the general principles for X-ray radiography as specified in IS 1182.

The image quality shall be in accordance with Class B of EN 462-3 (or equivalent). Images shall be retained digitally for approval if asked by the buyer.

16.7 Rejection Criteria

Acceptance criteria shall allow for the detection of all significant indications and as specified to level C in IS 3600 - 9 or level 2 in IS 1182.

16.8 Failure to Meet Test Requirements

If any test fails, two re-tests of the same type as that which failed shall be taken from the same test plate and both of these shall conform to the above requirements. If one or both of these re-tests fail to conform, the containers represented by these tests shall be rejected.

16.9 Lifting Points

16.9.1 Where lifting points are fitted, the design shall be proven by a type test in which a sample attachment is tested to two times the maximum gross weight without failure or significant deformation.

16.9.2 In production, each lifting point shall be subjected to a lift test at the gross weight. These tests can be carried out by attaching external weights to the container. After completion of the lifting test, all lifting eyes and their associated attachment welds shall be tested for crack defects on 10 percent of the batch in accordance with IS 7743 and IS 10724. If a defect is detected, then the entire batch shall be tested.

16.9.3 All structural welded joints shall be tested for defects, on 10 percent of the batch. If a defect is detected, then the entire batch shall be tested.

It is not necessary to carry out lifting test on containers which are to be lifted via fork lift/pallet truck pockets.

17 TYPE APPROVAL PROCEDURE

17.1 General Requirements

17.1.1 A technical specification of each new design of containers, or containers family as defined hereunder, including design drawings, design calculations, steel details, manufacturing process, and heat treatment details, shall be submitted by the manufacturer to statutory authority for approval. The type approval tests detailed in the present clause shall be carried out on each new design under the supervision of the inspecting agency authorized by statutory authority.

17.1.2 A container shall be considered to be of a new design (family), compared with an existing approved design, when at least one of the following applies:

- a) it is manufactured in a different factory;
- b) it is manufactured by a different process;
- c) it is manufactured according to a different material standard mentioned in the standard;
- d) it is given a different heat treatment;
- e) the protections of fittings are not in the limitation of this standard;
- f) the number of the opening has increased;
- g) the inside diameter of an opening has increased by 50 percent or more;
- h) the minimum design wall thickness or end thickness is changed by 25 percent or more; and
- j) the water capacity has change by more than 30 percent.

18 TYPE APPROVAL TESTS

18.1 Prototype Tests

18.2 Pressure Cycling Test

A container representative of the design shall be subjected to 12000 cycles, the upper pressure being the test pressure p_h , the lower pressure not exceeding 10 percent of p_h .

The design shall pass if there is no leakage of pressure at the end of the test. A representative finished container shall be used for the prototype work. This container shall be scrapped after the completion of the cycling testing.

18.3 Hydraulic Burst Test

A container representative of the design and manufacture, including the nameplate (which might be the container designed for the fatigue test), shall be subjected (after the batch tests described in this standard) to a burst test. The pressure shall be raised at a rate not exceeding 5 bar/min.

The design shall pass if reversal of an end, or other plastic deformation does not occur at a pressure less than 20 percent above p_h . The final burst test shall be without fragmentation. The minimum burst pressure shall be

- a) 2.25 p_h for a test pressure of less than 60 bar, and

18.4 Additional Test

In addition, tests required in 16 shall be performed.

19 MANUFACTURING TESTS ON EACH CONTAINER

19.1 Volume Check

The minimum volume (water capacity) of the container shall be checked against specification and recorded by the manufacturer.

19.2 Tare Weight Check

Each container shall be weighed to an accuracy of 1 percent or as agreed between buyer and manufacturer subject to a maximum variation of 1 percent, and the value shall be stamp marked on the name plate. The tare weight shall include all non-removable fittings and internal and external coatings, consistent with normal filling procedures.

19.3 Hydrostatic Test

19.3.1 Each container shall be subjected to a hydraulic proof pressure test at the test pressure, p_h , after all welding operations and heat treatment of the vessel have been completed, but before any lining or internal or external coating processes.

19.3.2 The water pressure in the vessel shall be increased at a controlled rate until the test pressure, p_h is reached.

19.3.3 The vessel shall remain under pressure, p_h , for at least 10 min to establish that the pressure does not fall and that there is no leakage.

19.3.4 The gaskets used on all pads, bosses, and other attachments for the test shall be of the same material and to the same dimensions as specified for the operating duty.

19.3.5 During the test the outside of the container shall be dry, and it shall be possible (with good access and illumination) to examine the welded seams. There shall be no leakage and no visible permanent deformation. There shall be no pressure drop at the end of the test.

19.3.6 If bolted connections leak, they shall be disassembled, the cause identified and corrected and the vessel re-tested. It is not permissible to apply excess torque to cure a leak.

19.4 Pneumatic Test

The Pneumatic test shall be conducted at 6 bar for minimum 10 minutes. While carrying out Pneumatic test, measures shall be taken to ensure safe operation considering the larger amount of stored energy, relative to the hydraulic test. It should be noted that pneumatic pressure tests require more precautions than hydraulic pressure tests since, regardless of the size of the container, any error in carrying out this test is highly likely to lead to a rupture under gas pressure. Therefore, these tests shall be carried out only after ensuring that the safety measures satisfy the safety requirements.

All seams and joints shall be examined for leaks by an appropriate detection method (e.g. soap solution testing). The drop in pressure should not exceed 1 percent .

19.5 Final Inspection

Each container shall have a final internal and external examination. If a container fails to meet the specification, it shall be rectified or rejected. Information to be marked.

19.6 Tightness Test

Each container shall be subjected to a leak test at a minimum pressure of 6 bar (e.g. using dry air or nitrogen as the pressure medium) when fitted as for use with studs, nuts, joints and valves. The joints shall be tested for leaks using a soap solution, or a method of equal sensitivity.

20 MARKING

20.1 Containers

Each container shall be permanently and legibly marked. Each cylinder shall be permanently stamped with the following in addition to the requirements of Gas Cylinder Rules and any other statutory requirements.

- a) Serial number, abbreviated name, monogram of the manufacturer and identification of the owner;
- b) Number of this Indian Standard;
- c) Maximum working pressure, in MPa;
- d) Test pressure, in MPa and date of hydrostatic test as the case may be (such as 3/20 for March 2020);
- e) Tare weight in kg, gross weight in kg and water capacity in litres;
- f) Inspecting agency's official mark;
- g) Name of gas;
- h) PRV set pressure; and
- j) Operating Temperature;

20.2 Position and Size of Marking

All markings shall be made on a plate either welded to the head of the container, or on a plate securely fixed to a shroud, support or other part that is a permanent part of the container. The plate shall have space to mark re-test dates. It shall be positioned so that it is accessible for re-stamping, but is not damaged under normal handling. The container serial number shall be in characters at least 10 mm high. Other container markings shall be at least 5 mm high.

21 CERTIFICATION

21.1 Manufacturing Conformance

Certification shall also be produced that confirms that all the containers made in a batch have been fabricated in accordance with the standard.

Container certification shall at least include:

- a) the serial number;
- b) the test pressure used;
- c) the minimum water capacity;
- d) a detailed drawing number;
- e) the construction materials used;
- f) PESO Approval no.; and
- g) PESO Approval for fittings;

21.2 Certificate

Each batch of containers shall be certified to state that they conform to the requirements of this standard.

A certification signed by the independent inspector appointed by Statutory Authority indicating that all tests and verification were performed with satisfactory results and that his mark has been applied on all pressure containers covered by the report and accepted by the inspector as being in conformance with the requirements set out in this part.

ANNEX A
(Clause 2)

LIST OF REFERRED STANDARDS

| | |
|---------------------------------|--|
| IS 1757 (Part 1) : 2014 | Metallic materials charpy pendulum impact test: Part 1 Test method (<i>third revision</i>) |
| IS 1182 : 1983 | Recommended practice for radiographic examination of fusion welded butt joints in steel plates (<i>second revision</i>) |
| IS 3023: 2012 | Recommended practice for building-up by thermal spraying (<i>first revision</i>) |
| IS 15326 (Part 2) : 2017 | Quality requirements for fusion welding of metallic materials Part 2 : Comprehensive quality requirements (<i>first revision</i>) |
| IS 3600 (Part 3) : 2018 | Method of testing fusion welded joints and weld metal in steel Part 3 Destructive tests on welds in metallic materials transverse tensile test (<i>fourth revision</i>) |
| IS 15914: 2011 | High tensile strength flat rolled steel plate (up to 6 mm), sheet and strip for the manufacture of welded gas cylinder — Specification |
| IS 1608 (Part 1) : 2018 | Metallic materials - Tensile testing Part 1 Method of test at room temperature (<i>fourth revision</i>) |
| IS 1599 : 2019 | Metallic materials - Bend test (<i>fourth revision</i>) |
| IS 7307 (Part 1) : 1974 | Approval tests for welders procedures Part 1 Fusion welding of steel |
| IS 7310 (Part 1) : 2019 | Approval tests for welders working to approved welding procedures - Part 1 : Fusion welding of steel (<i>first revision</i>) |
| IS 13805: 2004 | General standard for qualification and certification of non-destructive testing personnel – Specification (<i>first revision</i>) |
| IS 9122 : 2008 | Inspection gauges for checking type 2 taper thread of gas cylinder valves, taper 3 in 25 – Specification (<i>first revision</i>) |
| IS/ISO 11114 (Part 1) : 2012 | Transportable gas cylinders - Compatibility of cylinders and valve material with gas contents Part 1 Metallic materials |
| IS/ISO 11114(Part 2) : 2013 | Transportable gas cylinders compatibility of cylinder and valve material with gas contents Part 2 Non-metallic materials |
| IS/ISO 11114 (Part 4) : 2017 | Transportable gas cylinders-compatibility of cylinder and valve materials with gas contents : Part 4 Test methods for selecting metallic materials resistant to hydrogen embrittlement (<i>first revision</i>) |
| IS 16003 : 2012 | Specification and qualification of welding procedures for metallic materials general rules |
| IS 15326 (Part 1) : 2018 | Quality requirements for fusion welding of metallic materials Part 1 Criteria for the selection of the appropriate level of quality requirements (<i>first revision</i>) |
| IS 15326 (Part 2) : 2017 | Quality Requirements for fusion welding of metallic materials Part 2 : Comprehensive quality requirements (<i>first revision</i>) |
| IS 15326 (Part 3) : 2017 | Quality requirements for fusion welding of metallic materials - Part 3 : Standards quality requirements (<i>first revision</i>) |

| | |
|-----------------------------|---|
| | |
| IS 15326(Part 4) : 2017 | Quality Requirements for fusion welding of metallic materials - Part 4 : Elementary quality requirements (<i>first revision</i>) |
| IS 15326 : Part 5 : 2019 | Quality requirements for fusion welding of metallic materials Part 5 Documents with which it is necessary to conform to claim conformity to the quality requirements of ISO 3834-2, ISO 3834-3 or ISO 3834-4 (<i>first revision</i>) |

ANNEX B

REQUIREMENTS OF BUNGS / NOZZLES

B-1 FINISH

The bung / nozzles, shall be clean, even, without chatter and free from any visual defects and shall have the required machining finish. The threads shall be of smooth finished and shall not be broken at any point. The container manufacturer shall check on each finished machined bung / nozzle the dimensions that match with the corresponding dimensions on the container, such as neck diameter that fits into bung / nozzle hole etc. Bung/nozzle threads shall be inspected for conformity with the required sizes using all the gauges as laid down in the standards depending upon the nominal size and specification of the thread.

B-2 After welding and before fitting the valve, plug, or any other fitting, the bung / nozzle thread shall be cleaned with appropriate tap and checked for conformity to threads using specific thread plug gauges laid down in a particular standards depending upon the nominal size and specification of the thread.

B-3 However, the inspecting authority for the purpose of carrying out the inspection may test 3 percent of the lot of machined bungs / nozzles. In the event of any failure a second sample size of double the above shall be drawn and inspected. In case of failure of anyone out of the second draw, the whole lot shall be inspected and those not passing the requirement shall be rejected.

B-4 One bung / nozzle out of the sample size shall be sectioned and checked for conformity to thread form and finish.

B-5 The materials used for backing strip when used, shall conform to IS 2062 or steel of equivalent or superior qualities with compatible chemical composition with the body of the cylinder.

B-6 The materials used for other non-pressure parts like top shroud, bottom stand etc. shall conform to Grade '0' of IS 1079 or IS 2062 or IS 5986 or IS 2041 or ISO 9328 Part 1 to 5, or as agreed to between the purchaser and the manufacturer and approved by statutory body.