

BUREAU OF INDIAN STANDARDS**DRAFT FOR COMMENTS ONLY**

(*Not to be reproduced without the permission of BIS or used as an Indian Standard*)

भारतीय मानक मसौदा

खदानों में प्रयुक्त डीजल लोकोमोटिव हेतु विशिष्टि एवं सुरक्षा अपेक्षाएँ

(आई एस 9999 का *पहला पुनरीक्षण*)

Draft Indian Standard

**SAFETY REQUIREMENTS FOR DIESEL LOCOMOTIVES
USED IN MINES - SPECIFICATION**

(*First Revision of IS 9999*)

ICS 73.100

Mining Techniques and Equipment
Sectional Committee, MED 08

Last date for receipt of
comments is **05 September 2023**

FOREWORD

(*Formal clause to be added later*)

This standard was first published in 1981. The present revision has been undertaken up to incorporate the modification found necessary as a result of experience gained in the use of this standard. Also, in this revision, the standard has been brought into the latest style and format of Indian Standards, and references to Indian Standards, wherever applicable have been updated. BIS certification marking clause has been modified to align with the revised *Bureau of Indian Standards Act, 2016*. In this revision the amendment has been incorporated and major modifications brought under are as follows:

- a) Power Pack has been removed in this revision;
- b) The Exhaust System and Intake system have been modified;
- c) Cabin Light and Accessories have been removed;
- d) Terminology and General requirement have been modified;
- e) A Clause for Diesel Engine Systems has been added;
- f) A Clause firefighting system has been added;
- g) A Clause additional requirement has been added;
- h) Comma (,) has been used as a decimal marker, while in Indian Standards, the current practice is to use a point (.) as the decimal marker.

For the purpose of deciding whether a particular requirement of this standard is complied with, the final value, observed or calculated, expressing the result of a test or analysis, shall be rounded off in accordance with IS 2 : 2022 'Rules for rounding off numerical values (*second*

revision)'. The number of significant places retained in the rounded-off value should be the same as that of the specified value in this standard.

1 SCOPE

This Indian standard specifies the general safety requirements for Diesel Locomotives for use in mines and also covers diesel locomotives with explosion-protected engines when used as intended or under conditions of misuse reasonably foreseeable by the manufacturer.

2 REFERENCES

The standards listed below contain provisions which through reference in this text, constitute provisions of this standard. At the time of publication, the editions indicated were valid. All standards are subject to revision and parties to the agreement based on this standard are encouraged to investigate the possibility of applying the most recent editions of the standards indicated below:

<i>IS No./ Other Standards</i>	<i>Title</i>
IS 210 : 2009	Grey iron castings — Specification (<i>fifth revision</i>)
IS 1030 : 1998	Carbon steel castings for general engineering purposes — Specification (<i>fifth revision</i>)
IS 1570 Part 4 : 1988	Schedules for wrought steels: Part 4 alloy steels (Alloy Constructional and Spring Steels) with specified chemical composition and mechanical properties (<i>first revision</i>)
IS 1570 (Part 2) Sec 1 : 1979	Schedules for wrought steels: Part 2 carbon steels (Unalloyed Steels): Sec 1 wrought products (Other Than Wires) with specified chemical composition and related properties (<i>first revision</i>)
IS 1875 : 1992	Carbon steel billets, blooms, slabs and bars for forgings — Specification (<i>fifth revision</i>)
IS 2062 : 2011	Hot rolled medium and high tensile structural steel — Specification (<i>seventh revision</i>)
IS 2403 : 2014	Short Pitch transmission precision roller and bush chains, attachments and associated chain sprockets (<i>third revision</i>)
ISO 2631 Part 1 :1991	Mechanical vibration and shock — Evaluation of human exposure to whole-body vibration — Part 1: General requirements
IS 2707 : 1996	Carbon steel castings for surface hardening — Specification (<i>fourth revision</i>)
IS 2708 : 1993	1.5 percent manganese steel castings for general engineering purposes — Specification (<i>third revision</i>)
IS 3195 : 1992	Steel for the manufacture of volute and helical springs (For Railway Rolling Stock) - Specification (<i>third revision</i>)
IS 3431 : 1982	Specification for steel for the manufacture of volute helical and laminated springs for automotive suspension (<i>second revision</i>)
IS/ISO 3449 : 2005	Earth Moving machinery – Falling – Object protective structures – Laboratory tests and performance requirements
ISO 3457 : 2003	Earth Moving machinery – Guards – Definitions and requirements
IS 3885 (Part 2) : 1992	Steel for the manufacture of laminated springs (Railway Rollingstock): Part 2 rib and groove sections (<i>second revision</i>)
IS 4432 : 1988	Specification for case hardening steels (<i>first revision</i>)

IS 4368 : 1967	Specification for alloy steel billets, blooms and slabs for forging for general engineering purposes
IS/ISO 6683 : 2005	Earth-Moving Machinery - Seat Belts and Seat Belt Anchorages - Performance Requirements and Tests
IS 15683 : 2018	Portable Fire Extinguishers — Performance and Construction — Specification (<i>first revision</i>)
IS 16819 : 2018 ISO 12100:2010	Safety of machinery - General principles for design - Risk assessment and risk reduction
IS/IEC 60079-1 : 2014	Explosive Atmospheres - Part 1 : Equipment Protection by Flameproof Enclosures "d"
IS/IEC 60079-11 : 2011	Explosive Atmospheres Part 11 : Equipment Protection by Intrinsic Safety "i" (<i>first revision</i>)

3 TERMINOLOGY

3.1 Static (Adhesive) Weight – The static weight of a locomotive on powered axles.

3.2 Installed Power – The power (in kW) of a diesel engine installed in the locomotive, under standard conditions of test.

3.3 Maximum Speed – The maximum speed attainable on a level track by a locomotive at full throttle position.

3.4 Minimum Continuous Rated Speed — This is the minimum speed below which the locomotive shall not be permitted to be run under full load for more than five minutes. This criteria are applicable only in the case of hydrodynamic transmission where the efficiency is low at low speed.

3.5 Diesel Engine System – A Diesel Engine that includes its inlet system, air boost systems, exhaust system, cooling systems, recirculation systems, starting systems, shutdown systems, control systems, emissions treatment systems and other ancillary equipment specifically used to start and run the diesel engine such as air compressors, hydraulic pumps, alternators and batteries etc.

3.6 Explosion-Protected Diesel Engine System – A diesel engine system designed, manufactured, maintained and operated in such a way that it shall not generate and or propagate flame or sparks capable of initiating an explosion of the surrounding atmosphere

3.7 Operator – A competent person, suitably trained, duly authorized and provided with necessary instructions for the safe operation of the locomotive.

3.8 Brake System – All components which combine together to stop or hold the locomotive along with fully loaded tubs or other means, including the brake control, brake actuation system, and the brakes themselves.

3.9 Service Brake System – Primary brake system used for stopping and holding the locomotive along with fully loaded tubs or other means.

3.10 Secondary Brake System – A brake system used to stop the locomotive along with fully loaded tubs or other means during the emergency in the event of any failure in the Service Brake system.

3.11 Park Brake System – A brake system used to hold a stopped locomotive along with fully loaded tubs or other means.

3.12 Automatic Fire Detection, Suppression and Engine Shut Down System for Diesel Locomotive – An automatic system to detect and suppress fire in hot zones of machine and is capable of sensing, activating and delivering the fire suppression agent(s) without human intervention in the event of fire with additional provision for manual actuation and appropriate indication and warning to Operator by incorporating one or more kinds of heat sensing system and suitable fire suppressant agents and provide for automatic shutdown of the engine.

4 TYPES

As specified in Table 1.

5 MAIN DIMENSIONS

As specified in Table 2.

6 MATERIAL

6.1. Main components of locomotives shall be manufactured from material as mentioned against each in Table 3 or its equivalent.

6.2. Aluminum, magnesium, titanium or their alloys shall not be used in the construction of any component of locomotives having explosion-protected engines.

Table 1 Type of Diesel Locomotives
(Clause 4)

Sl No.	Type		Nominal Static Weight tonnes	Rail Gauge G mm
	Non-flameproof	Explosion Protected		
(1)	(2)	(3)	(4)	(5)
i)	LD 5	LDE5	5	600
ii)	LD 5	LDE 5	5	(762)
iii)	LD 5	LDE 5	5	900
iv)	LD8	LDE 8	8	600
v)	LD8	LDE 8	8	(762)
vi)	LD8	LDE 8	8	900
vii)	LD8	LDE 8	8	1000
viii)	LD8	LDE 8	8	(1 067)
ix)	LD12	LDE 12	12	900
x)	LD12	LDE 12	12	1 000
xi)	LD12	LDE 12	12	(1 067)
xii)	LD15	LDE 15	15	900
xiii)	LD15	LDE 15	15	1 000
xiv)	LD15	LDE 15	15	(1 067)

Note — Rail gauge in brackets are non-preferred and shall not be used for new Installations.

Table 2 Dimensions, Ratings and Main Parameters of Diesel Locomotives
(Clause 5)

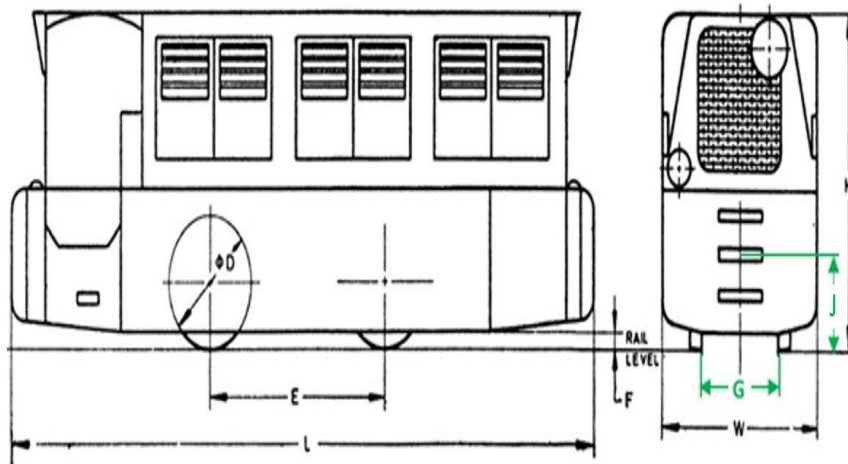

All dimensions in millimetres.

Sl No.	Type of Locomotives	LD5 or LDE5	LD8 or LDE8	LD12 or LDE12	LD15 or LDE15
(1)	(2)	(3)	(4)	(5)	(6)
i)	Static weight, kg	5 000 + 20 Percent	8 000 + 15 Percent	12 000+10 Percent	15 000 + 10 Percent
ii)	Power of locomotive, kW	22.5 to 30	30 to 37.5	37.5 to 67.5	93.5
iii)	Length over buffers, <i>L, Max</i>	3 600	4 750	5 600	5 600
iv)	Total width, <i>W, Max</i>	G + 500	G + 500	G + 500	G + 500
v)	Height over rail level, <i>H, Max</i>	1 750	1 750	1 750	1 750
vi)	Wheelbase, <i>E</i>	950	1 200	1 500	1 400 – 1 500
vii)	Wheel diameter (rolling), <i>D</i>	450 or 540	540 or 680	680	680 or 725
viii)	Minimum clearance (worn-out wheel)	50	50	50	50
ix)	Minimum negotiable radius of curvature	7 000	9 000	10 000	10 000
x)	Weight of rail per metre, kg	Not less than 14	Not less than 20	Not less than 23	Not less than 23
xi)	Brake system	Mechanical /pneumatic /Hydraulic	Mechanical /pneumatic /Hydraulic	Mechanical /pneumatic /Hydraulic	Mechanical /pneumatic /Hydraulic
xii)	Sanding system	Mechanical	Mechanical	Mechanical or pneumatic	Mechanical or pneumatic

Note — The drawbar/buffer height (J) as depicted in Fig. shall be consistent with height of tub buffer used in the mine.

Table 3 Materials for Main Components of the Locomotives
(Clause 6.1)

Sl No	Component	Material Conforming to
(1)	(2)	(3)
1	Frame	IS 2062
a)	Frame, If cast	IS 1030
2	Drive	
a)	Axle, shaft and pins	E 450 of IS 2062 or Class 4 of IS 1875 or C 45 or 40Cr1Mo28 of IS 4368
b)	Pinion shaft and gears	40Cr1, 13Ni3Cr80 and 15NiCr1Mo12 of IS 4368 or 40Cr5Mo6 of IS 1570 Part 4
c)	Worm Gears	Phosphor bronze, or
d)	Wheel tyre	Grade 3A or 3B of IS 2708 or 40Cr1 of IS 1570 (Part 4)
e)	Wheel centres	Grade 25 of IS 210 or Grade 30-57 of IS 1030 or Class 3 A or 4 of IS 1875
f)	Cast wheel	Grade 2 of IS 2707
g)	Axle Box housing, Gear Box Housing and covers of Gear Box Housing	IS 1030 or IS 2062
h)	Sprocket	Class 1 of IS 1875 or C14 of IS 4432 or 40Cr1Mo28 of IS 4368
j)	Chains	IS 2403
3	Braking System	
a)	Brake spindle and hinge pins	Class 3A or 4 of IS 1875 or 45C8 of IS 1570 (Part 2) Sec 1
b)	Levers, hanger, etc	IS 2062
c)	Hand wheel	IS 1030 or Grade 20 of IS 210
d)	Brake shoe (without liner)	Grade 15 of IS 210
e)	Brake shoe (with liner)	To be checked
	(i) Shoe	Grade 30-57 of IS 1030
	(ii) Liner	Grade 15 of IS 210
4	Sanding System	
a)	Levers, tie rods, sand containers	E 410 of IS 2062
b)	Hinge Pins	Medium Carbon Steel
5	Buffers, Bracket, Spring Housing	Grade 30-57 of IS 1030 or E 410 IS 2062
6	Suspension Springs, Buffer's Springs, Frame Suspension Springs	Steel conforming to IS 3195 or 55 Si7 of IS 3431 IS 3885 (Part 2)

7 DESIGNATION

A Diesel Locomotive shall be designated by its commonly used name, type, rail gauge for which it is to be used and the number of this standard.

Example: A Diesel Locomotive (Explosion Protected) of type LBE8 for use on a rail gauge of 900 mm shall be designated as:

Diesel Locomotive 3 LBE8

Note —The numbers 1, 2, 3, 4 and 5 shall be used to designate the rail gauge of 600, (762), 900, 1000 and (1067) mm respectively prior to the type in the designation of the locomotive.

8 GENERAL REQUIREMENTS

Diesel Locomotives shall comply with the specification and safety requirements of this standard. In addition, the machine shall be designed according to the principles of IS 16819.

8.1 Access Systems

Access systems shall be provided to the operator's station and to routine maintenance points.

8.2 Operator's Station

The operator's station of Diesel Locomotives shall be fitted with an ergonomically designed cab. The cab shall be designed to prevent projection of Operator's body parts outside the envelope of the cab or coming into accidental contact with the roof, side of haulage roadway or any other structures. The height of the cabin shall be not less than 1.2 m.

8.3 Operator's Seat

The Operator's station shall be fitted with an ergonomically designed adjustable seat that supports the operator in a position that allows the operator to control the machine under the intended operating conditions and the operator shall have a clear line of sight in front as well as at the rear of the locomotive without involving any constraint or strain. The seat and its suspension shall be so designed to reduce vibration transmitted to the operator to the lowest level that can be reasonably achieved.

8.4 Vibration

The vibration exposure limits of the operator shall be within the limits specified in ISO 2631 Part 1.

8.5 Noise

The locomotive shall be designed in such a way not to expose the operator to noise level that exceeds an eight-hour equivalent continuous sound pressure level of 85 dB.

8.6 Restraint System

Machines fitted with ROPS and or TOPS shall have an operator restraint system in accordance with IS/ISO 6683.

8.7 Operator's Controls and Indicators

Following control equipment, Instruments including gauges and indicators shall be provided in the cabin of the locomotives for their safe operation:

8.7.1 Controls:

- a) Engine throttle control;
- b) Engine starting and stopping control;
- c) Forward-reverse control;
- d) Brake controls including secondary/emergency brake.
- e) Sanding control;
- f) Horn/warning;
- g) Lighting control;
- h) Emergency Engine Stop; and
- j) Pre-start Alarm control.

8.7.2 Instruments and Gauges

- a) Engine RPM/hour meter;
- b) Engine lube oil pressure gauge;
- c) Engine water temperature gauge;
- d) Fuel level indicator;
- e) Transmission oil temperature gauge (where applicable);
- f) Transmission oil pressure gauge (where applicable);
- g) Hydraulic oil temperature gauge (where applicable);
- h) Air pressure gauge for brake system (where applicable);
- j) Battery charge and discharge ammeter; (for non-explosion protected locomotives only);
- k) Voltmeter for control circuit; (for non-explosion protected locomotives only);
- m) Speedometer if the speed of a locomotive exceeds 15 km/h on a level rail track;
- n) Filter clog indicators for air;
- p) Exhaust outlet temperature gauge (for explosion-protected locomotives only); and
- q) Wet scrubber water level indicator (for explosion-protected locomotives only).

8.7.3 Audio Visual Signals or Panel Lights for

- a) Low lubricating oil pressure warning;
- b) Engine coolant high temperature warning; and
- c) Low water level for wet scrubber.

8.8 Starting and Stopping System

Diesel Locomotives shall be equipped with a starting and stopping device (for example, a key). The Locomotives shall be so designed that movement of the locomotive shall not be possible, while starting or stopping the engine. The normal engine stop device is within the zone of reach of the operator.

8.9 Inadvertent Activation

Controls that can cause a hazard due to inadvertent activation shall be so arranged, deactivated or guarded to minimize the risk, particularly while the operator is getting into or out of the

operator's station. The deactivation device shall either be self-acting or shall act by compulsory actuation of the relevant device.

8.10 Pedals

Pedals shall be of an appropriate size, shape and shall be adequately spaced. They shall have a slip-resistant surface and be easy to clean. If the pedals of the locomotive have the same function (clutch, brake, and accelerator) as on a motor vehicle, they shall be arranged in the same manner to avoid the risk of confusion.

8.11 Visual Displays/Control Panels

The operator shall be able to see from the operator's station, in either daylight or darkness, the necessary indicators allowing a check of the proper function of the machine.

8.12 Doors and Windows

Doors, windows and flaps shall be securely held in their intended operating positions. Doors shall be retained at their intended operating positions by a positive engagement device. Windows shall be made of safety glass or other material that provides similar safety performance. The front window shall be fitted with motorized windscreen wipers and washers. The tank of the window washers shall be easily accessible.

8.13 Inner Lighting

The cab shall be fitted with a fixed inner lighting system and shall be able to function with the engine stopped. Suitable provisions shall be made in the locomotive to fix a portable light.

8.14 Instruction Storage

A space intended for the safekeeping of the operator's manual and other instructions shall be provided near the operator's station. The space shall be lockable, unless the space is inside the operator's station, and the operator's station can be locked.

8.15 Sharp Edges

The operator's working space within the operator's station (for example, ceiling, inner walls, instrument panels and access to the operator's station) shall not present any sharp exposed edges or acute angles/corners.

8.16 The Operator's Controls and Indicators shall be arranged in the operator's cabin so as to be within easy reach of the operator from his / her driving position. Controls shall be laid out and designed to allow easy and safe operation based on the principle that a governed direction of movement of any control produces a consistent and expected effect. Marking of all controls shall be indelible and illuminated to enable the operator to see the controls, gauges and warnings without the use of cap lamps. When a control such as a keyboard or a joystick control is designed and constructed to carry out several functions, the activated functions shall be clearly marked for such functions.

8.17 Climatic Conditions

Suitable ventilation system shall be provided in case of a closed operator's cabin. The ventilation system shall be capable of providing the cab with filtered fresh air. Pipes and hoses that contain fluids at pressures exceeding 5 MPa or temperatures above 60 °C located inside the cab shall be guarded in accordance with clause 9 of IS/ISO 3457.

8.18 Operator Protective Structures

8.18.1 *Falling-object Protective Structures (FOPS)*

Diesel Locomotives shall be so designed that a FOPS can be fitted when they are intended for applications where there is a risk of falling objects. The fitted FOPS shall be in accordance with IS/ISO 3449. For the belowground operation of the Locomotives, the FOPS shall be designed and tested for Level II as prescribed in IS/ISO 3449.

8.18.2 *Replacement of Operator Protective Structure*

Machines shall be designed such that operator protective structures can be replaced, according to the manufacturer's specification. The manufacturer shall instruct the end-user to replace the protective structure if the structure experiences plastic deformation or rupture that has an impact on its integrity.

8.19 Retro-reflective reflectors shall be provided at each end of the locomotive.

8.20 An adequate audible warning signal of an approach like a gang bell operated by mechanical action shall be provided in addition to an electric or pneumatic horn. A suitable audio-visual Alarm that functions automatically when controls for reverse movement of the locomotive is engaged by the operator.

8.21 Moving Parts

All the moving parts that can create a hazard of crushing, shearing or cutting shall be designed, constructed, positioned or provided with guards or protective devices that minimise the risk. Guards shall comply with IS/ISO 3457. Fixed guards that are to be removed as a part of routine maintenance, described in the operator's manual, shall be fixed by systems that can be opened or removed only with tools. Fixed guards that are removable for routine maintenance shall have a means of fastening that shall remain attached to the guards or to the machinery when the guards are removed.

8.22 Covers and Shields

All pipes and hoses of fuel oil and lubricants shall be adequately covered so that oil from any kind of leakage is prevented from contacting any exposed metal surface where the temperature exceeds 120 °C under any condition of the equipment.

8.23 The underframe shall be rigid and robust in construction and basically rectangular in shape. Adequate cross members shall be provided in the under frame for rigidity which may serve as supports for the power pack equipment.

8.24 The drawing and buffing gears shall suit the rolling stock for use in the mines. Locomotives of 12 tonnes and 15 tonnes static weight shall be provided with spring-loaded buffer and draw gear. Other locomotives may be provided with rubber pads between the underframe headstock and the draw gear.

8.25 Cut-outs shall be provided in the side plates of the underframe for inspection and accessibility of the brake gear components, sanding gear, etc.

9 SUSPENSION

9.1 The underframe shall be supported on the axle box through springs of either coil or leaf type. The spring gear shall be so designed that the static deflection of each spring under working conditions is between 20 and 35 mm.

9.2 In case coil spring suspension is used, a shock absorber may be provided between the frame and axle boxes only. No shock absorber will be necessary when laminated leaf springs are used for suspension.

10 BRAKE SYSTEM

10.1 All locomotives shall be equipped with a Service Brake system, a secondary brake system and a parking brake system. The parking brake may also serve as a secondary brake system. One of the brake systems shall automatically apply to bring the Locomotive into rest within a reasonable distance when any one of the following occurs:

- a) Sooner the source of energy used for the operation of the brake system falls below the safe operating level;
- b) When the engine is shut down; and
- c) Whenever the engine oil pressure is low.

10.2 Lever-type braking system if provided on the locomotives shall have automatic self-locking arrangements.

10.3 In case of pneumatic brake system, the air reservoir pressure shall be 6 to 8 bar and the working pressure for braking systems shall be between 3 to 5 bar. A suitable cut-off arrangement at 8 Bar Pressure shall be provided for the air reservoir. A suitable Pressure Relief valve shall be provided in the Air Reservoir.

10.4 All pipelines of the brake systems shall be rigidly secured to the underframe by robust clamps and brackets. All pipe joints shall be of compression type as far as possible.

10.5 Air brake / Hydraulic brake application shall be of graduated application type so that variation of application of brakes is possible through adjustment of the brake valve handle/pedal. An emergency brake valve shall be provided separately for use in an emergency when the driver's graduated application valve fails to operate.

10.6 The compressor capacity shall be not less than 16 m³/h for locomotives with pneumatic brakes.

10.7 Braking system of all types of locomotives shall be provided with a suitable arrangement for adjusting clearance between the brake shoe and the wheel tread.

10.8 Sanding System

Suitable sanding arrangements shall be provided on the locomotives which can be easily operated from the driver's seat. The sanding arrangements may be of either gravity or pneumatic type and shall allow sand to fall on the rails in front of the wheels both for forward and backward movement of the locomotives.

10.9 For the pneumatic type of sanding arrangement, a suitable device shall be provided in the airline, so that the sand falls on the track and is not blown off.

11 DIESEL ENGINE SYSTEM

11.1 The Diesel Engine System shall have the followings subsystems:

- a) Efficient air intake with air cleaning/filtering system;
- b) Fuel system comprising fuel tank, fuel lines, fuel filtration system with water separators and fuel injection system;
- c) Efficient engine cooling system using water-based coolants;
- d) Turbochargers and after coolers, if engine design requirements so warrant;
- e) Engine protection system;
- f) Exhaust system; and
- g) Cooling system for Hydraulic transmission, if provided.

11.2 Intake System

Air intake and filter housings shall be located away from heat sources, exhaust and dust sources like tyres. Diesel engines used for below-ground mining purposes shall be equipped with a two-stage intake filter system. Engine intake filter choke indicators shall be provided. The choke indicators shall be mounted in a location which is easily monitored by the operator. A flame trap shall be provided in the Intake system.

11.3 Engine Compartment

11.3.1 Fuel tank and Hydraulic Tank shall not form part of the Engine compartment. Routing of fuel lines, Hydraulic oil lines and other electrical lines shall be kept as minimum as possible. These lines, when provided, shall be adequately shielded from hot spots and against possible damage during the operation and maintenance of the locomotive. A firewall or a barrier shall be installed to separate the engine compartment from the hydraulic system components.

11.3.2 All the hoses shall be of a fire-resistant type and shall be routed away from hot engine surfaces and shall be adequately covered so that oil from any kind of leakage is prevented from contacting any exposed hot metal surface of the Engine and ancillary equipment in the compartment under any condition of equipment use. Additionally, such hot metal surfaces may be shrouded or heat shielded to reduce the temperature.

11.3.3 Transmission belts used in the diesel engine shall be of fire-resistant and anti-static (FRAS) type.

11.3.4 The engine crankcase breather shall not be connected to the air intake system of the engine. The discharge from the breather shall be directed away from hot surfaces and in such a

way as to ensure that the external surfaces of the engine and exhaust system do not become fouled with oil.

11.3.5 Engine exhaust shall be adequately designed so that flames or glowing particles are not emitted from the engine compartment under any condition of use. Discharge from the engine breather shall be directed away from external surfaces of the engine system in such a way as not to foul such surfaces with oil. The temperature of any surface of the engine that comes into contact with mine atmosphere shall not exceed 150 °C under any operating conditions.

11.4 Cooling System

Radiator caps or coolant reservoir caps provided for the cooling system shall be fitted with means for safely relieving pressure to prevent scalding of persons. The caps shall be guarded against damage by foreign objects. The caps shall be adequately secured by the chain or wire rope to prevent inadvertent flying and resulting injuries at the time of opening. A device shall be provided to stop the engine automatically in the event of an abnormal rise in the temperature of the cooling water and in any case in the event of temperature exceeding 112 °C.

11.5 Fuel System

All fuel lines shall be of heat-resistant, corrosion-resistant double braided hoses or metal pipes and shall be adequately secured. Fuel filter elements shall be enclosed within suitable containers. Fuel tanks shall be of substantial construction and shall be protected against possible damage during the operation and maintenance of the locomotive. Fuel tanks shall be fitted with non-leaking caps and the caps shall be effective under all conditions and shall be secured to the tank. No engine other than that worked by a liquid fuel of flash point, not less than 68 °C shall be used. The engine shall be of compression ignition type.

11.6 Engine Protection System

The engine shall be provided with suitable sensors to monitor and control engine performance, temperature and level of engine coolant and lubricating oil, pressure of lubricating oil, etc. When the sensor register value is different from the pre-set parameter value limit, the engine protection system shall force the engine to decrease torque and warn the operator. The engine shall be provided with suitable sampling points for monitoring engine lubricating oil pressure, engine RPM, engine coolant temperature, inlet manifold vacuum, exhaust back pressure and gas stream emissions before and after exhaust treatment, the temperature of emission etc.

11.7 Flame Trap

A flame trap shall comply with the following requirements:

- a) It shall be interposed between the inlet manifold and the air cleaner and in the exhaust system in case of use in coal mine;
- b) Be so located as to facilitate easy removal for cleaning and maintenance;
- c) It shall be designed to prevent incorrect assembly;
- d) It shall be so mounted that it is protected, as far as possible, from accidental damage;
- e) It shall be constructed of corrosion-resistant materials and shall be of adequate strength to minimise the possibility of distortion of components;
- f) In the case of flame trap of spaced plate type, plates of thickness not less than 1.25 mm and a width (parallel to the flow of inlet air) of not less than 50 mm, shall be so arranged

as to provide a maximum uniform gap of 0.5 mm between the plates, and shall be of the removable type so that they can be easily cleaned and reassembled; and

- g) Flame traps other than spaced plate type may be accepted provided they are equal to the flame traps of spaced plate types in performance and are easily removable for inspection, cleaning and replacement.

11.8 Exhaust System

The exhaust system shall consist of an exhaust pipe from the exhaust manifold, exhaust conditioner, exhaust cooling and dilution system and silencer.

- a) The exhaust system shall be provided with monitoring and shutdown devices. In addition, flame trap and spark arrester shall be provided for the engines designed to be used for coal mines;
- b) Exhaust pipe shall be of double-walled construction to reduce exhaust pipe surface temperature and shall be manufactured from stainless steel to resist corrosion;
- c) Exhaust conditioner and catalytic convertor shall be capable of diluting and rendering exhaust gases harmless;
- d) The Exhaust system shall be designed to discharge final diluted exhaust gases in such a manner that they are directed away from the operator compartment and also away from the breathing zones of persons likely to be alongside the locomotives;
- e) Provision for the sampling of the exhaust gases shall be made in the exhaust system before and after the conditioner box;
- f) The water capacity of the exhaust gas cooling system shall be sufficient to permit the engine to operate at one-third load factor for a period of 8 hours;
- g) The exhaust manifold shall be water-cooled and the exhaust pipes leading to the conditioner box shall not be allowed to exceed a surface temperature of 150 °C;
- h) Flame traps of suitable design, preferably interchangeable with those provided on the air intake system shall be provided on the exhaust system after the conditioner box;
- j) The temperature of the exhaust gas discharged from the flame trap or conditioner box whichever is later, shall not exceed 85 °C under any throttle condition; and
- k) Insulating material shall not be used on any part of the engine or exhaust system.

11.9 Exhaust Gases

The exhaust gases, as sampled at the engine exhaust manifold, when the engine is on a test, shall not contain under any load condition (idling, half-load, full-load) more than 1 500 ppm and 1 000 ppm of carbon monoxide and oxides of nitrogen respectively.

11.10 Transmission

A suitable mechanical or hydraulic transmission shall be provided on the locomotives to achieve the required tractive effort.

11.11 Fire-resistant hydraulic fluid of flash point not less than 68 °C shall be used.

12 SAFETY CONTROL

12.1 A device shall be provided to stop the engine automatically when the water level in the exhaust gas container goes below a pre-determined minimum level or when the exhaust gas

temperature at the outlet of the frame trap exceeds 85 °C. Additionally, an alarm may be provided which shall sound continuously till the deficiencies are removed

12.2 Any such alarm, if provided, shall be so arranged that its operation does not affect the performance of the traps or other safety equipment operated by the pneumatic system. In case, an air shut-off valve is provided, provision shall be made to prevent water from the conditioner box being sucked into the engine.

12.3 Any safety device or alarm provided in accordance with **12.1** shall prevent restarting of the engine until the water level is replenished or deficiencies are removed.

13 JOINT

13.1 Combustion Chamber

Joints in the combustion chamber shall comply with the following requirements:

- a) The cylinder head joints shall have a minimum width of 9 mm. Taking into account, any gasket interposed between the faces of the joints, the joint shall form a positive seal;
- b) The injector body shall be positively sealed to the cylinder head. This seal shall be backed by a flame path to the surrounding atmosphere with a minimum length of 12.5 mm and a maximum diametral clearance of 0.15 mm or a minimum length of 50 mm and a maximum clearance of 0.5 mm;
- c) Diametral clearances between the valve stem and valve guides shall not exceed 0.15 mm for a minimum length of 25 mm; and
- d) Any other non-operational openings into the combustion chamber or inlet and exhaust ports shall be positively sealed in a manner which shall comply with **13.2 (c)**.

13.2 Inlet and Exhaust System Including Conditioner Box

Joints in this system shall comply with the following requirements:

- a) All joints shall be machined and flanged. Suitably designed screw joints may be accepted as an alternative at certain intermediate connections. The flatness tolerances of each surface of mating joints shall not exceed 0.15 mm;
- b) The edge of any bolt or stud hole shall be not less than 9 mm from the inner edge of the joint surface. The width of any joint or the length of any flame path through or across any joint shall not be less than 12.5 mm. For spigot joints, the length of the flame path may be measured over the spigot and the flange together, provided that both spigot and flange lengths are continuous. For screwed joints, the flame path is the axial dimension across the threads common to both portions when fully connected. Screwed joints shall have a minimum of 5 fully engaged threads;
- c) When the enclosure is pierced by a valve spindle, a gland shall be provided at which the diametral clearance shall not exceed 0.15 mm for a minimum axial length of 25 mm;
- d) Suitable metal clad gaskets or other jointing material shall be interposed between all joint faces except in the case of:
 - 1) Screwed joints, and
 - 2) Joints which need to be broken to remove flame traps. The flanges of such joints shall be of corrosion-resistant material and shall have flatness tolerances at their faces not exceeding 0.075 mm.

14 ATTACHMENT OF COMPONENTS

The attachment of components shall comply with the following requirements:

- a) **Fuel Pump** — A fuel injection pump shall be so designed that alteration of the setting of the pump is not possible while it is attached to the engine. The pump shall be clearly marked with its rated setting;
- b) If removable screws or studs are used for attaching covers for components of an enclosure or for attaching any fitting thereto, the holes for such screws or studs shall not pass through the wall of the enclosure. A thickness of metal not less than 3 mm or one-third of the diameter of the hole, whichever is greater, shall be left at the bottom and around all such holes;
- c) If for convenience in manufacture, the holes are drilled through the wall of the enclosure, such holes shall be sealed by the insertion of screwed plug of a length not less than 6 mm or the diameter of the hole whichever is greater. The diameter of any such hole except where it is less than 6 mm, shall be not greater than the thickness of the enclosure wall.
- d) Screws, studs or screwed plugs, which are to be permanently attached to the apparatus, shall be securely attached by welding, riveting or other acceptable means; and
- e) Where set screws or studs inserted in bottomed or blind holes are used for attaching a cover plate or access door or other components, all the set screws or studs for any such component shall be of same length if they are of the same diameter and pitch. The use of screws or bolts of different lengths through holes in the same cover shall be avoided as far as possible.

15 DRIVE

15.1 All gears and sprockets shall be suitably heat treated to achieve the required mechanical properties. The drive to the wheels for the main transmission shall be preferably through roller chains and sprockets.

15.2 Wheels

15.2.1 Locomotives shall have either solid cast steel wheels with integral wheel tyres or steel tyre wheels with cast steel centre. The wheel tyre shall be pressed or shrink fitted on to the wheel centre.

15.2.2 The distance between backgauge contour of the flange and tread of wheels shall have dimensions as laid down in Fig. 1.

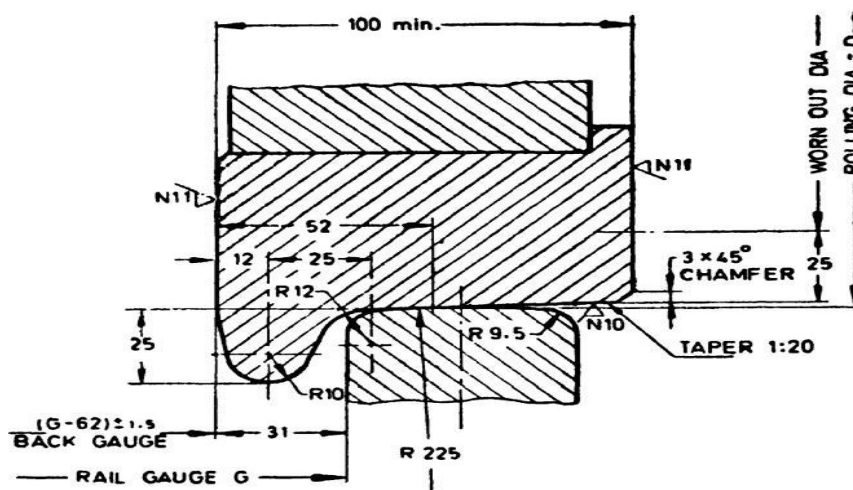

All dimensions in millimetres

FIG. 1 DIMENSIONS OF WHEEL CONTOUR

15.3 Axle Box

15.3.1 An axle box shall be designed to contain a sufficient quantity of grease and shall be dustproof. The axle box housing shall be provided with a renewable wear plate when fitted with horn guides.

15.3.2 Bearings of axle boxes shall be of an anti-friction type such as taper roller, spherical roller or cylindrical roller bearing and shall conform to relevant Indian Standards (*see* Annex A).

15.3.3 An axle box shall be so designed that it can allow free vertical movement of horn guides which are fixed to the frame by riveting, welding, bolting or by fitted bolts.

16 ELECTRICALS AND LIGHTING

16.1 A 12/24 Volt electrical system shall be provided on the locomotive complete with batteries, starter motor in case of a non-explosion protected engine, dynamo and lighting system.

16.2 Headlight

Each locomotive shall be provided with two headlights, one at each end. The headlights shall be capable of showing any obstacle on the road ahead within 60 m of the locomotives.

16.2.1 The headlight shall have sufficient range to enable the driver of the locomotive to stop within the limit of his vision when the locomotive is driving at its maximum operational speed.

16.3 Tail Light

A red tail light shall be provided at each end of the locomotive. The tail lights shall be of sufficient power, to be visible from a distance of 60 m.

16.3.1 Where a locomotive is capable of operation in both directions, the switching circuit for the headlight and tail light shall be so arranged that when the headlight in one direction is put on, the tail light in the other direction is automatically illuminated.

16.4 For diesel locomotives with Explosion protected characteristics, all electrical apparatus fitted including headlight, tail light, instruments and other controls provided on the locomotives shall be either flameproof or intrinsically safe and shall conform to either IS 60079 -1 (or latest) or IS 60079 -11.

16.5 Cable connecting flameproof apparatus shall be either pliable armoured or conducted, the cables being routed away from the hot surfaces.

17 FIRE FIGHTING SYSTEM

17.1 Automatic Fire Detection, Suppression and Engine Shut Down System

The system shall have “system healthy” and “system malfunction” indications to indicate its status. The system shall be provided with Manual actuation control(s) inside the operator cabin

and outside of the operator cabin preferably away from hot zones. Components of the system shall in no way obstruct the operator's line of sight hindering his / her visibility. The system shall cover all fire susceptible areas including the engine, diesel tank, battery box, transmission, exhaust pipe and other hot zones having the potential to cause a fire. The system, as far as practicable, shall be designed in such a way to supply an adequate quantity of fire suppressing agent to the zone where the fire is detected and to be suppressed on a need basis for effective firefighting and to avoid re-ignition of fire instead of blind discharge through all discharge nozzles. The system shall provide for automatic engine shutdown when the alarm alerts the operator.

17.2 In addition, A portable fire extinguisher conforming to IS 15683 a minimum capacity of 2 kg shall be provided in each of the operator's cabins.

17.3 An instruction manual for proper maintenance and overhaul of locomotive shall be provided with each locomotive.

17.4 All the components used in the manufacture of diesel engines and locomotives shall conform to Indian Standards. A list of related Indian Standards is given in Annex A.

18 PAINTING

18.1 Suitable painting as agreed between the manufacturer and the purchaser shall be applied to the locomotive.

18.2 Luminous paint shall be applied at a conspicuous area on both ends, front and rear, of the locomotive preferably in a recessed portion in addition to the reflector. For guidance, the design of painting is indicated in Fig. 2.

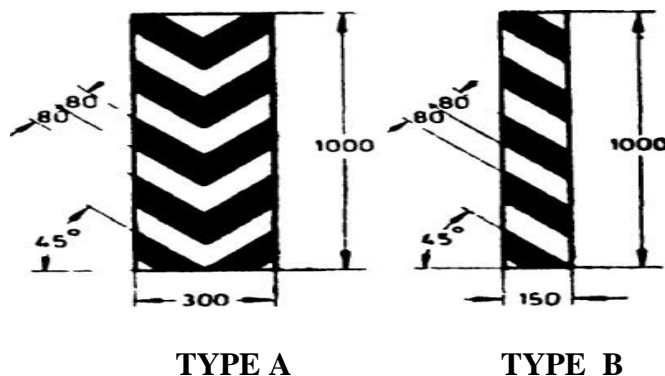

All dimensions in millimetres
FIG. 2 DESIGN OF PAINTING ON ENDS OF LOCOMOTIVES

19 ADDITIONAL REQUIREMENTS

Additional requirements for Diesel engines designed to be used in belowground coal mines and belowground metalliferous mines where:

- a) in any part in which an explosion or ignition of inflammable gases occurred;
- b) in any ventilation district in which inflammable gas has been found; and
- c) in any place, in the opinion of DGMS, inflammable gas is likely to be present in such quantities as to render the use of Internal Combustion Engines dangerous.

19.1 Every diesel engine for use in belowground coal mines shall be designed confirming to standards notified for explosion-protected diesel engines by the Directorate General of Mines safety from time to time.

19.2 The diesel engine for use in belowground Coal Mines shall be explosion protected and the engine shall be so constructed that together with its associated air intake, cooling and exhaust system, it shall be able to withstand without permanent deformation any explosion that may occur within the system and prevent the propagation to the outside atmosphere of any flame or sparks or heated particles that may initiate an explosion of the flammable explosive atmosphere.

19.3 The engine shall be of compression ignition type, diesel-fuelled and water-cooled type. The engine may be naturally aspirating, turbocharged and or supercharged. The diesel engine system shall also be designed for limited-time safe operation in a belowground atmosphere containing up to 1 Percent methane.

19.4 The locomotive shall be fitted with at least one methane detector to detect the general body concentration of methane around the vehicle. The methane detector shall automatically activate an Audio cum Visual alarm to warn the operator when the concentration of methane exceeds 0.5 Percent and shall shut off the engine when the concentration of methane exceeds 0.75 Percent.

19.5 All rotating components external to the engine (e.g., fan hubs, fan blades, pulleys) shall not be made of light metal and its alloys (which is incentive to sparking) and the use of non-metallic materials for external components of the engine system shall be kept to a minimum. Where such materials are used, they shall be shielded and routed away from the heat source.

19.6 Air inlet system shall also have an inlet manifold vacuum monitor. The flame traps provided at the inlet and exhaust shall be capable of preventing the propagation of an explosion at all angles of inclination of locomotives during its operation, derailment and tilting. The wet scrubber system shall be for exhaust gases.

19.7 Ignition system of a diesel engine shall be of either pneumatic or hydraulic or other explosion-protected systems. The ignition system shall be readily available at all times and a suitable portable type of such system shall also be made available with the locomotive at all times.

19.8 Compressors forming part of diesel engine shall be water cooled. Hoses that are attached to the compressor delivery port shall be of poly Tetra Fluoro Ethylene (PTFE) steel wired reinforced braided construction or equivalent heat-resistant material. There shall be no valve between the unloader and the compressor.

19.9 Following 'Fail to Safe' safety shutdown systems shall be provided in the Explosion protected Engine system to shut down the engine:

- a) Low Oil pressure;
- b) High coolant temperature;
- c) Loss of engine coolant;
- d) Manual fuel shut off;
- e) High exhaust gas temperature;
- f) Low water/coolant level;

- g) Low water in the scrubber system;
- h) Sensing device for fume dilution system;
- j) Spark arrestor sensing device;
- k) Device to ensure safe operation of the particulate filter; and
- m) Emergency engine Stop system.

19.10 In case of shutdown of the engine initiated by any one of the above safety shutdown systems, the shall not be able to be restarted until the fault is completely rectified, except for the allowed automatic override features like low oil pressure and low coolant pressure. Wherever the automatic override is provided in the engine system, the period of override shall not exceed the OEM specifications.

19.11 Warning labels shall not be manufactured from light metals and their alloys which are incentives to sparking.

19.12 The engine and the exhaust system shall be designed to emit undiluted exhaust gas emissions after treatment not more than –

- a) 0.010 Percent (100PPM) by volume of NO₂ ;
- b) 0.09 Percent (900 PPM by volume of NO;
- c) 0.11 Percent (1100) PPM by volume of CO; and
- d) 0.20 Percent (2000 PPM) by volume of CO when 1 Percent CH₄ is injected into the intake.

19.13 Only a wet scrubber system shall be provided in such locomotives.

19.14. For diesel locomotives with explosion-protected characteristics all electrical apparatus fitted including headlight, tail light, instruments and other controls provided on the locomotives shall be either flameproof or intrinsically safe and shall conform to either IS/IEC 60079-1 or IS/IEC 60079-11.

20 MARKING

Every locomotive shall be marked with the following information:

- a) Name of the manufacturer of the locomotive;
- b) Name of the manufacturer, type and serial number of the diesel engine;
- c) Rated power of the engine;
- d) The type and setting of the fuel pump of the engine; and
- e) The number of the test report of the locomotive.

20.1 BIS Certification Marking

The diesel locomotives may also be marked with Standard Mark.

20.1.1 The product(s) conforming to the requirements of this standard may be certified as per the conformity assessment schemes under the provisions of the *Bureau of Indian Standards Act, 2016* and the Rules and Regulations framed thereunder, and the products may be marked with the Standard Mark.

21 TESTS

Tests as specified in **21.1** to **21.3** shall be performed at the manufacturer's or purchaser's premises. The results of the tests shall be endorsed on a certificate of test (*see* Annex B). Further, the test method and test certificates for Explosion protected Diesel engines shall be in accordance with type and format as specified by the Director General of Mines Safety from time to time

21.1 Bench Test of the Drive

21.1.1 After the complete assembly of the locomotive, it shall be either jacked up or put on test stand and shall be run in either direction for 45 minutes during which various systems such as braking, sanding, power transmission, etc, shall be checked and the results of examination shall be endorsed on test certificate (*see* Annex B).

21.1.2 In case of hydraulic transmission, the locomotive shall be jacked up allowing the wheels to rotate freely. The engine shall be run for sufficient time to bring all systems to attain working pressure and temperature. The brakes shall then be applied and engine speed gradually increased, stalling the output of the converter. The engine speed at full throttle with the wheels locked by braking shall be recorded. If the wheels start rotating against the brakes, still the engine speed shall be recorded. The temperature and pressure of the torque converter oil, engine water and engine lubricating oil circuits shall be recorded.

21.2 Running Test

21.2.1 *No load test*

The locomotive shall be run freely at the purchaser's premises on the track covering curves, points, crossing, etc. Performance of the brake system and the ability of the locomotive to negotiate curves, points, crossing, etc, shall be recorded.

21.2.2 *Half-load test*

On completion of the no-load test, a trailing load of half of the recommended capacity of the locomotive shall be attached to the locomotive. The locomotive shall be run for a few hours. Engine speed, oil temperature and pressure, and water temperature shall be recorded.

21.2.3 *Full-load test*

The trailing load shall be increased in steps to full load capacity. The locomotive shall be run on the maximum rising gradient and the cruising speed shall be noted. In case the recorded speed of the locomotive with a full load is less than the minimum continuous rated speed, the trailing load shall be decreased. By trial and error method, the trailing load shall be adjusted to achieve a speed higher than the minimum continuous rated speed on the maximum ruling gradient.

21.2.3.1 The load arrived at in accordance with **21.2.3** shall be recorded in the certificate of test and the purchaser shall be instructed not to exceed this load at any time while using the locomotive.

21.3 Stand Still Test

The locomotive shall be brought to rest using any means provided in the locomotive other than direct mechanical action. The locomotive shall be kept at rest for a minimum period of 10

minutes. No leakage shall occur in the air/hydraulic circuits of the braking system of locomotives during or after the completion of this test.

22 INFORMATION TO BE SUPPLIED BY USER WHILE ORDERING

While ordering, the user shall give the following information to the manufacturer:

- a) Track gauge;
- b) Maximum ruling gradient against the load;
- c) Minimum radius of curvature of the track;
- d) Maximum allowable axle load in tonnes;
- e) Maximum speed limit desired;
- f) Acceptable maximum length of the locomotive over buffers;
- g) Acceptable maximum width of the locomotive over handrails/farthest projection;
- h) Maximum permissible height of locomotive; and
- j) If tunnels exist, the tunnel size may be given.

23 INFORMATION TO BE SUPPLIED BY MANUFACTURER

The following information shall be supplied with each locomotive by the manufacturer to the user at the time of supply:

- a) Type of locomotive;
- b) Number of axles;
- c) Maximum rigid wheelbase;
- d) Weight of locomotive;
- e) Maximum axle load;
- f) Diameter of the wheel when new;
- g) Diameter of the wheel at recommended condemning limit;
- h) Minimum clearance above rail level with new wheels;
- j) Installed power of the diesel engine at standard conditions;
- k) Derating, if any, on the diesel engine for working at site conditions (specify the following site conditions):
 - 1) Altitude in metres above m. s. I. ,
 - 2) Maximum ambient temperature,
 - 3) Humidity;
- m) Type of transmission (hydraulic/mechanical/hydrostatic);
- n) Minimum continuous rated speed of locomotive (for hydraulic transmission);
- p) Maximum tractive effort at wheels attainable at minimum continuous rated speed;
- q) Fuel tank capacity; and
- r) Maximum braking distance at specifications.

ANNEX A

(Clause 15.3.2 and 17.4)

LIST OF INDIAN STANDARDS RELATING TO DIESEL LOCOMOTIVES FOR USE IN MINES

A-1 DIESEL ENGINES

IS 810 : 1991	Internal combustion engines - Engine valves - Specification (<i>second revision</i>)
IS 3170 (Part 1) : 2006 / ISO 2697:1999	Internal Combustion Engines - Fuel Injection Nozzles Part 1 Injection Nozzles - Size `S' (<i>second revision</i>)
IS 3170 (Part 2) : 2006 / IS 3170 (Part 2) : 2006 ISO 4010:1998	Internal combustion engines - Fuel injection nozzles: Part 2 calibrating nozzle, delay pintle type (<i>first revision</i>)
IS 3171 (Part 1) : 1997 ISO 2699:1994	Internal Combustion Engines - Fuel Injection Nozzle Holders - Part 1 : Flange Mounted Fuel Injectors Size `S' Types 2, 3, 4, 5 and 6
IS 3171 (Part 2) : 2006 ISO 7026:1997	Internal Combustion Engines - Fuel Injection Nozzle Holders - Part 2 : Screw-in Injection Nozzle Holders, Types 20, 21, 21.1 and 27 for Pintle Nozzle Size `S', Type B
IS 3171 (Part 3) : 1997 ISO 7030:1987	Internal combustion engines - Fuel injection nozzle holders: Part 3 screw mounted injection nozzle holders, types 12,13,14,15,16,17,18 and 19
IS 3172 : 1997	Internal combustion engines - Fuel injection equipment - Single and double ended pipe unions (Single And Double Ended Banjo) - Specification (<i>second revision</i>)
IS 3173 : 1965	High pressure connections for fuel injection equipment for diesel engines
IS 3174 : 1974	Pipe union bolt (<i>first revision</i>)
IS 3175 : 2013	Internal combustion engine - Sealing washers for pipe unions - Specification (<i>second revision</i>)
IS 3351 : 2006 ISO 4020:2001	Road vehicles - Fuel filters for diesel . engines - Test methods (<i>second revision</i>)
IS 5791 : 2006 ISO 6621-3:2000	Technical supply conditions for piston rings for IC engines
IS 6740 : 1985	Specification for gudgeon pins for internal combustion engines (<i>first revision</i>)
IS 6750 : 1985	Specification for cylinder liners for internal combustion engines (<i>first revision</i>)
IS 7449 (Part 1) : 1974	Glossary of terms for IC engines: Part 1 fuel injection equipment
IS 7451 (Part 6) : 2007 ISO 2261:1994	Reciprocating internal combustion engines: Part 6 hand - Operated control devices - Standard direction of motion (<i>first revision</i>)
IS 8422 (Part 1) : 1977	Piston rings for IC engines : Part 1 R-rings — Plain compression rings from 30 up to 200 mm nominal diameter
IS 8422 (Part 2) : 1977	Piston rings for IC engines : Part 2 M-rings —Taper faced compression rings from 30 up to 200 mm nominal diameter
IS 8422 (Part 3) : 1977	Piston rings for IC engines : Part 3 T-rings — 15°-keystone rings from 82 up to 200 mm nominal diameter

IS 8422 (Part 4) : 1977	Piston rings for IC engines : Part 4 N-rings — Napier oil scraper rings from 30 up to 200 mm nominal diameter
IS 8422 (Part 5) : 1977	Piston rings for IC engines : Part 5 Z-rings — Stepped oil scraper rings from 30 up to 200 mm nominal diameter
IS 8422 (Part 6) : 1977	Piston rings for IC engines : Part 6 S-rings — Slotted oil control rings from 50 up to 200 mm nominal diameter
IS 8422 (Part 7) : 1977	Piston rings for IC engines : Part 7 G-rings — Double beveled slotted oil control rings from 50 up to 200 mm nominal diameter
IS 8422 (Part 8) : 1977	Piston rings for IC engines : Part 8 D-rings — Narrow land slotted oil control rings from 50 up to 200 mm nominal diameter
IS 8503 : 1986	Technical supply conditions for aluminium alloy pistons for internal combustion engines (<i>first revision</i>)

A-2 FASTENERS

IS 549 : 2005 ISO 1234 : 1997	Split pins - Specification (<i>third revision</i>)
IS 1363 (Part 1) : 2019 ISO 4016 : 2011	Hexagon Head Bolts, Screws and Nuts of Product Grade ‘C’ Part 1 Hexagon Head Bolts (Size Range M 5 to M 64) (<i>fifth revision</i>)
IS 1363 (Part 2) : 2018 ISO 4018:2011	Hexagon Head Bolts, Screws and Nuts of Product Grade ‘C’ Part 2 Hexagon Head Screws (Size Range M 5 to M 64) (<i>fifth revision</i>)
IS 1363 (Part 3) : 2018 ISO 4034 : 2012	Hexagon Head Bolts, Screws and Nuts of Product Grade C Part 3 (Style 1) Hexagon Nuts (Size Range M 5 to M 64) (<i>fifth revision</i>)
IS 1364 (Part 1) : 2018 ISO 4014 : 2011	Hexagon head bolts, screws and nuts of product grades A and B: Part 1 hexagon head bolts (Size Range M 1.6 To M 64) (<i>fifth revision</i>)
IS 1364 (Part 2) : 2018 ISO 4017	Hexagon head bolts, screws and nuts of product grades A and B: Part 2 hexagon head screws (Size Range M 1.6 To M 64) (<i>fifth revision</i>)
IS 1364 (Part 3) : 2018 ISO 4032	Hexagon Head Bolts, Screws and Nuts of Product Grades A and B Part 3 Hexagon Nuts, Style 1 (Size Range M 1.6 To M 64)
IS 1367 (Part 1) : 2014 ISO 8992 : 2005	Technical supply conditions for threaded steel fasteners: Part 1 general requirements for bolts, screws, studs and nuts (<i>fourth revision</i>)
IS 1367 (Part 2) : 2002 ISO 4759-1:2000	Technical supply conditions for threaded steel fasteners: Part 2 tolerances for fasteners - Bolts, screws, studs and nuts - Product grades a, b and c (<i>third revision</i>)
IS 1367 (Part 3) : 2017 ISO 898-1 : 2013	Technical supply conditions for threaded steel fasteners: Part 3 mechanical properties of fasteners made of carbon steel and bolts, screws and studs (<i>fifth revision</i>)
IS 1367 (Part 6) : 2018 ISO 898-2 : 2012	Technical supply conditions for threaded steel fasteners: Part 6 mechanical properties of fasteners made of carbon steel and alloy steel - Nuts with specified property classes - Coarse thread and fine pitch thread (<i>fourth revision</i>)
IS 1367 (Part 9/Sec 1) : 1993 ISO 6157-1 :1988	Technical supply conditions for threaded steel fasteners: Part 9 surface discontinuities section 1 bolts, screws and studs for general applications (<i>third revision</i>)

IS 1367 (Part 10) : 2002 ISO 6157-2:1995	Technical supply conditions for threaded steel fasteners: Part 10 surface discontinuities - Nuts (<i>third revision</i>)
IS 1367 (Part 16) : 2002 ISO 8991:1986	Technical supply conditions for threaded steel fasteners: Part 16 designation system for fasteners (<i>third revision</i>)
IS 1367 (Part 18) : 1996	Industrial fasteners - Threaded steel fasteners - Technical supply conditions: Part 18 packaging (<i>third revision</i>)
IS 1368 : 2018 ISO 4753 : 2011	Dimensions for ends of parts with external ISO metric threads (<i>fourth revision</i>)
IS 1369 (Part 1) : 1993 ISO 3508 : 1976	Fasteners - Thread run - Outs and under - cuts: Part 1 dimensions for screw thread run - Outs for external ISO metric threads (<i>third revision</i>)
IS 1821 : 1987 ISO 273-1979	Dimensions for clearance holes for bolts and screws (<i>third revision</i>)
IS 1862 : 1975	Specification for studs (<i>second revision</i>)
IS 2232 : 1967	Specification for slotted and castle nuts (<i>first revision</i>)
IS 2269 : 2006 ISO 4762:2004	Hexagon socket head cap screws (<i>fifth revision</i>)
IS 2393 : 2010 ISO 2338 : 1997	Parallel pins, of unhardened steel and austenitic stainless steel (<i>third revision</i>)
IS 2585 : 2006	Square head bolts, screws and square nuts of product grade C – Specification (<i>second revision</i>)
IS 1367 (Part 17) : 2023 ISO 3269 : 2019	Technical supply conditions for threaded steel fasteners: Part 17 inspections, sampling and acceptance procedure (<i>fourth revision</i>)
IS 4218 (Part 4) : 2001 ISO 262:1998	ISO general purpose metric screw threads: Part 4 selected sizes for screws, bolts and nuts (<i>second revision</i>)
IS 3640 : 1982	Specification for hexagon fit bolts (<i>first revision</i>)
IS 4172 : 2005 ISO 885:2000	General purpose bolts and screws - Metric series - Radii under the head (<i>second revision</i>)
IS 4206 : 2012 ISO 888 : 2012	Dimensions for nominal lengths and thread lengths for bolts, screws and studs (<i>second revision</i>)
IS 4499 : 1968	Dimensions for depth of holes for studs
IS 6688 : 2005 ISO 2339:1986	Taper pins, unhardened (<i>second revision</i>)
IS 6862 : 2005 ISO 2340 : 1986	Clews pins without head (<i>second revision</i>)
IS 7790 : 1991	Domed cap nuts - Specification (<i>first revision</i>)
IS 7795 : 2004	Hexagon nuts with collar - Specification (<i>first revision</i>)
IS 8535 : 2020 ISO 1891 : 2009	Fasteners — Terminology (<i>second revision</i>)
IS 8536 : 2021 ISO 225 : 2010	Fasteners - Bolts screws studs and nuts - Symbols and designation of dimensions First Revision IS 8536
IS 9519 : 2005 ISO 272:1982	Fasteners - Hexagon products - Width across flats (<i>first revision</i>)
IS 9549 (Part 1) : 2014 ISO 7378 : 1983	Fasteners - Bolts, screws and studs: Part 1 split pin holes and wire holes (<i>first revision</i>)
IS 9549 (Part 2) : 2014	Fasteners - Bolts, screws and studs - Head slots for bolts (<i>first revision</i>)

A-3 BEARINGS

IS 2398 : 1967	Identification code for rolling bearings
IS 3090 : 1965	Code of practice for installation and maintenance of rolling bearings
IS 3823 : 2014 ISO 76 : 2006	Rolling bearings - Static load ratings (<i>third revision</i>)
IS 3824 : 2014 ISO 281 : 2007	Rolling bearings - Dynamic load ratings and rating life (<i>third revision</i>)
IS 5669 : 2019 ISO 15 : 2017	Rolling bearings - Radial bearings - Boundary dimensions, general plan (<i>second revision</i>)
IS 5692 : 2019 ISO 492 : 2014	Rolling bearings - Radial bearings - Geometrical product specifications (GPS) and tolerance values (<i>second revision</i>)
IS 5932 : 2019 ISO 104	Rolling bearings - Thrust bearings - Boundary dimensions, general plan (<i>second revision</i>)
IS 5933 : 2019 ISO 199 : 2014	Rolling bearings - Thrust bearings - Geometrical product specification (GPS) and tolerance values (<i>fourth revision</i>)
IS 6453 : 1984	Technical supply conditions for rolling bearing
IS 6454 : 1972	Specification for self - Aligning roller bearings
IS 6455 : 2020	Single Row Deep Groove Ball Bearings — Specification (<i>first revision</i>)
IS 6456 : 1972	Specification for double row radial ball bearings
IS 6457 : 1972	Specification for single row cylindrical roller bearings
IS 6458 : 1972	Specification for double row cylindrical roller bearings
IS 5692 : 2019	Rolling bearings - Radial bearings - Geometrical product specifications (GPS) and tolerance values (<i>second revision</i>)
IS 7461 : 2019 ISO 355 : 2007	General plan of - Boundary dimensions for tapered roller bearings: Part 1 single row bearings (<i>second revision</i>)

A-4 MISCELLANEOUS

IS 2048 : 1983	Specification for parallel keys and keyways (<i>second revision</i>)
IS 2291 : 1990 ISO 3117	Tangential keys and keyways (<i>third revision</i>)
IS 2292 : 1974	Specification for taper keys and keyways (<i>first revision</i>)
IS 2403 : 2014 ISO 606	Short - Pitch transmission precision roller and bush chains, attachments and associated chain sprockets (<i>third revision</i>)
IS 2712 : 1998	Gaskets and packings - Compressed asbestos fibre jointing - Specification (<i>third revision</i>)
IS 3688 : 1990 ISO 775	Power transmission - Shafts - Dimensions for cylindrical and 1/10 conical shaft ends (<i>second revision</i>)
IS 4278 : 1988	Specification for flexible shafts for speedometers and tachographs (Second Revision)
IS 7714 : 1975	Method of sealability test for gasket material
IS 7906 (Part 1) : 1997	Helical compression springs: Part 1. design and calculation for springs made from circular section wire and bar (<i>first revision</i>)
IS 7906 (Part 2) : 1975	Helical compression springs: Part 2 specification for cold coiled springs made from circular section wire and bar
IS 7906 (Part 3) : 1975	Helical compression springs: Part 3 data sheet for specifications for springs made from circular section wire and bar

IS 7907 (Part 1) : 2004	Helical extension springs October 2004: Part 1 design and calculation for springs made from circular section wire and bar (<i>first revision</i>)
IS 7907 (Part 2) : 1976	Helical extension springs: Part 2 specification for cold coiled springs made from circular section wire and bar
IS 7907 (Part 3) : 1975	Helical extension springs : Part 3 Data sheet for specification for springs made from circular section wire and bar

ANNEX B

(Clause 21 and 21.1.1)

TEST CERTIFICATE FOR DIESEL LOCOMOTIVES FOR USE IN MINES

The test certificate for diesel locomotives for use in mines shall contain the following information:

- a) Identification of locomotive;
- b) Name of the manufacturer;
- c) Overall dimensions;
- d) Minimum rail clearance;
- e) Performance of engine starting system;
- f) Time taken for the build-up of compressed air pressure in the system (if applicable);
- g) Performance of various systems of the locomotive during bench test (*see* 21.1):
 - 1) Electrical system,
 - 2) Brake system,
 - 3) Sanding system,
 - 4) Horn,
 - 5) Windscreen wiper,
 - 6) Power transmission,
 - 7) Leakage in oil, air and fuel pipeline systems,
 - 8) In the case of hydraulic transmission, give the following information (*see* 21.1.2):
 - i) Engine speed,
 - ii) Temperature and pressure of torque converter oil,
 - iii) Cooling water temperature and pressure,
 - iv) Lubricating oil temperature and pressure;
- h) Results of a running test at no-load (*see* 21.2.1);
- j) Results of a running test at half-load (*see* 21.2.2):
 - 1) Speed of engine,
 - 2) Temperature and pressure of oil,
 - 3) Temperature of cooling water;
- k) Results of a running test at full-load (*see* 21.2.3.1):
 - 1) Maximum trailing load to be attached to a locomotive,
 - 2) Cruising speed with maximum trailing load at maximum rising gradient; and
- m) Results of standstill test (*see* 21.3).