

For BIS Use Only

BUREAU OF INDIAN STANDARDS

DRAFT FOR COMMENTS ONLY

(Not to be reproduced without the permission of BIS or used as an Indian Standard)

भारतीय मानक मसौदा

खदान ढुलाई ट्रैक के लिए डॉग स्पाइक्स — विशिष्टि

(आई एस 10046 का पहला पुनरीक्षण)

Draft Indian Standard

**DOG SPIKES FOR MINE
HAULAGE TRACKS — SPECIFICATION**

(First Revision of IS 10046)

ICS 73.100.01

**Mining Techniques and Equipment
Sectional Committee, MED 08**

**Last date for receipt of
comments is 04 November 2022**

FOREWORD

(Formal clause to be added later)

This standard was first published in 1981. This standard is being revised again to keep pace with the latest technological developments and international practices. In this revision, the following major changes have been made:

1. A reference clause has been added mentioning the latest version of all the referred standards.
2. Editorial corrections have been done.

This standard lays down the requirements for dog spikes (also called dog nails) used in laying of mine haulage -tracks. This standard covers two types of dog spikes -one with a chisel shaped tail (Type C) and other with a rounded tail (Type R).

Of the two, the Type C dog spikes find greater use in Indian mines. These dog spikes are easily driven into the wooden sleeper and are easier to manufacture (may be manufactured in mine

workshops). In addition, their use involves lesser damage to sleepers thus increasing the life of sleepers. Due to these advantages, the use of these dog spikes is recommended at places where track layout is frequently changed, high speeds are not involved, rails used are comparatively of lighter section and haulage tracks are not permanent in nature. These dog spikes are therefore, normally used for laying tracks near working faces, at places where locomotive haulage is not used, etc.

On the other hand the Type R dog spikes, though not in demand, are recommended for use where track is comparatively of permanent nature, high speeds of vehicles are involved, locomotives are expected to run on the tracks and rails are of heavier section. These dog spikes are, therefore, preferred at trunk haulage routes. pit-bottom and pit-top layouts, etc.

For laying the haulage track, Type C dog spikes are driven directly into the sleeper by hammering the head whereas Type R dog spikes are driven into the sleeper after drilling a blind hole in the sleeper with an auger.

For the purpose of deciding whether a particular requirement of this standard is complied with, the final value, observed or calculated, expressing the result of a test or analysis, shall be rounded off in accordance with IS 2 : 2022 ‘Rules for rounding off numerical values (*second revision*)’. The number of significant places retained in the rounded-off value should be the same as that of the specified value in this standard.

1 SCOPE

Lays down the requirements for dog spikes (also called dog nails) for mine haulage and locomotive tracks.

2 REFERENCES

The standards listed below contain provisions which through reference in this text, constitute provisions of this standard. At the time of publication, the editions indicated were valid. All standards are subject to revision and parties to the agreement based on this standard are encouraged to investigate the possibility of applying the most recent editions of the standards indicated below:

<i>IS No.</i>	<i>Title</i>
2062 : 2011	Hot rolled medium and high tensile structural steel — Specification (<i>seventh revision</i>)

3 TYPES

Type C — Dog spike with chisel shaped tail.

Type R — Dog spike with rounded tail.

4 DIMENSIONS

4.1 Type C Dog Spikes

All dimension in millimeters.

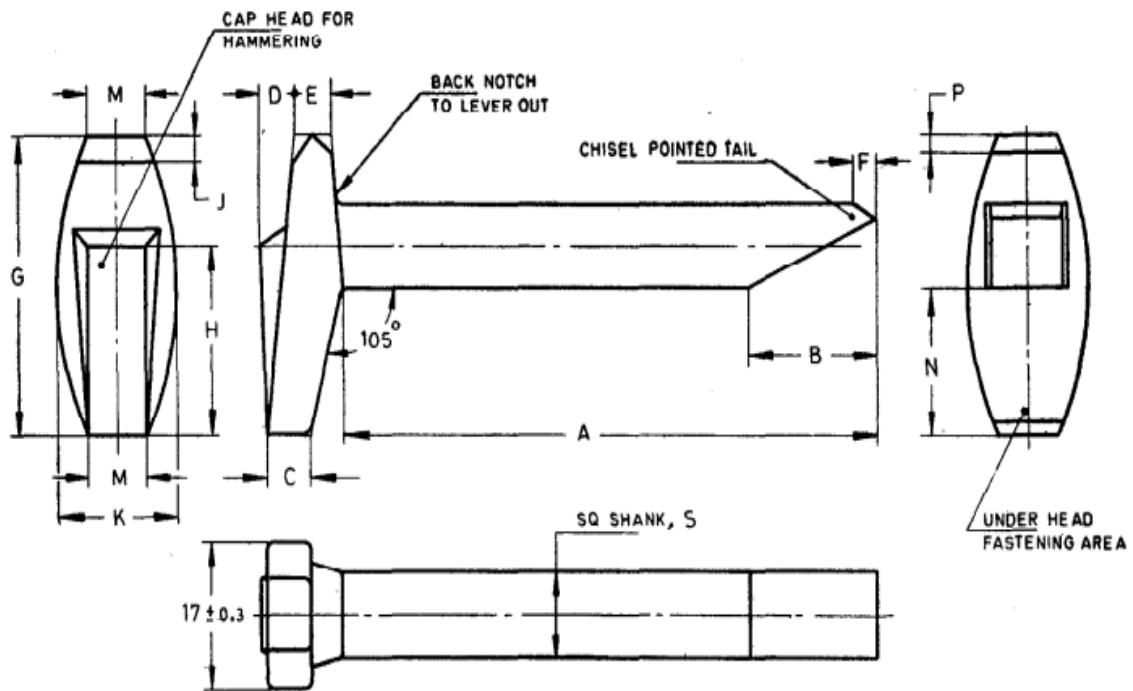

Nominal Size	Size Square Shank	Length of Shank A	B	C	D	E	F	G ± 0.5	H	J	K	M Min	N	P	Suitable for Rail Section kg/m
10×85	10	75 ± 0.5	18	6	5	5	5	3	35	22	3	17	8	17	10
10×100	10	88 ± 1	18	8	5	5	7	3	35	22	3	17	8	17	10, 12
12×100	12	88 ± 1	22	8	5	5	7	8	42	26	5	22	10	20	10, 12, 15
12×115	12	102 ± 1	22	8	5	5	8	8	42	26	5	22	10	20	15, 24

4.2 Type R Dog Spikes

All dimensions in millimetres.

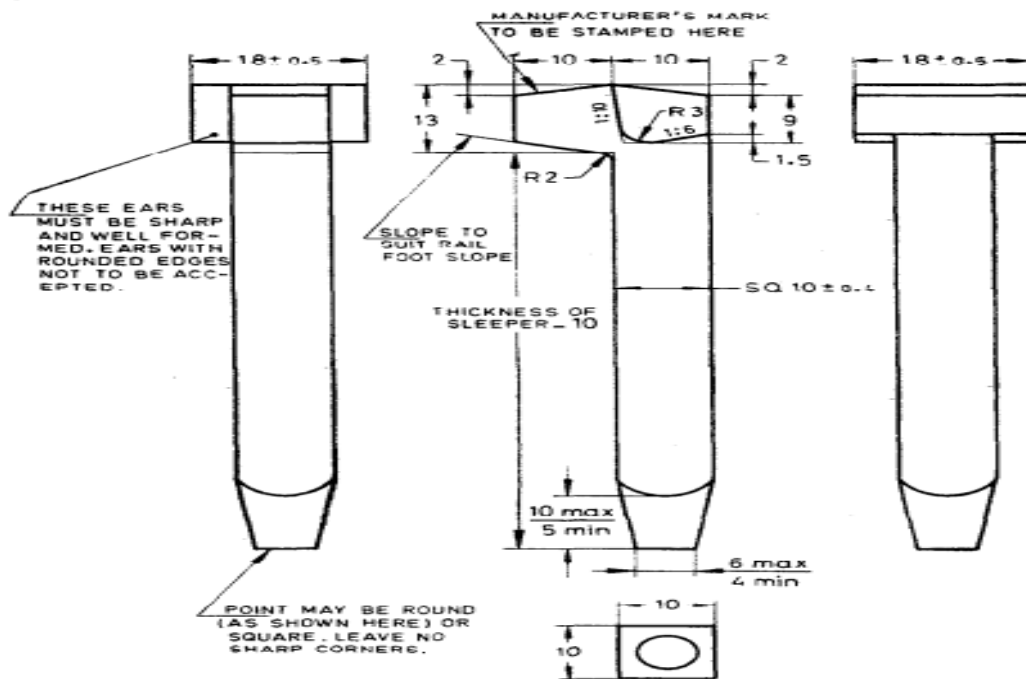

5 MATERIAL

Steel conforming to IS 2062

6 DESIGNATION

Type C dog spikes of 12 × 100 nominal size conforming to this standard shall be designated as:

Dog Spike 12 × 100C IS 10046

7 MARKING

Each spike shall be marked with manufacturer's identification mark or trade-mark and nominal size.

7.1 BIS Certification Marking.

The product(s) conforming to the requirements of this standard may be certified as per the conformity assessment schemes under the provisions of the *Bureau of Indian Standards Act, 2016* and the Rules and Regulations framed thereunder, and the products may be marked with the standard mark