

BUREAU OF INDIAN STANDARDS

DRAFT FOR COMMENTS ONLY

(Not to be reproduced without the permission of BIS or used as an Indian Standard)

भारतीय मानक मसौदा

**द्रवित पेट्रोलियम गैस के साथ प्रयुक्त घरेलू गैस चुल्हे
और निर्मित हॉब्स — विशिष्टि**

(आई एस 4246 का छठा पुनरीक्षण)

Draft Indian Standard

**DOMESTIC GAS STOVE AND BUILT IN HOB FOR
USE WITH LPG — SPECIFICATION**

(Sixth Revision of IS 4246)

ICS 75.160.30, 97.040.20

Domestic and Commercial Gas Burning
Appliances Sectional Committee, MED 23

Last date for comments is
09 January 2025

FOREWORD

(Formal clause to be added later)

This standard was first published in 1967 and then subsequently revised in 1972, 1978, 1984, 1992 and 2002. The present revision has been taken up with a view to incorporating the modifications found necessary as a result of experience gained on the use of this standard. Also, in this revision, the standard has been brought into the latest style and format of Indian Standard, and references to Indian Standards, wherever applicable have been updated. The BIS certification marking clause has been modified to align with the revised *Bureau of Indian Standards Act, 2016*.

The major changes in the standard has been listed below:

- a) The scope of the standard has been enlarged to cover, metallic or plastic frame with glass top;
- b) Provisions of Built-in Hobs have been incorporated in this standard;
- c) Provision of Bati stand has been modified;
- d) Amendments issued from time to time has been incorporated;
- e) Provisions of thermal shock test and resistance to draught has been modified;
- f) New provision for design of pan support has been added;
- g) Clause **14** (Gas Inlet connections) and **16** (Thermal Efficiency test) has been modified; and
- h) Correction factor has been added in Gas Consumption test;
- j) New provisions for gas rate at STP have been added in table 1.

Doc: MED 23(27077)WC
December 2024

This standard is one of a series of Indian Standards on various domestic and commercial gas burning appliances (pressure type) used with LPG. General requirements of this equipment are covered in IS 5116 : 2020 'General requirements for domestic and commercial equipment for use with LPG (*fourth revision*)', which is a necessary adjunct to this standard. Should, however, any deviation exist between the requirements given in IS 5116 and those of this standard, provisions of the latter shall apply. Other standards published so far in this series are IS 4473 : 2002 'Domestic gas ovens for use with liquefied gases (*first revision*)', IS 4760 :2002 'Domestic cooking ranges for use with liquefied gases (*third revision*)', and IS 11480 : 2023 'Domestic grillers for use with liquefied gases (*second revision*)'.

The domestic and commercial gas burning appliances (pressure type) sectional committee examined EN 30-1-1, 'Domestic cooking appliance burning gas published by European Committee for standardization'. It may be noted that gas stove/built in hob which passes as per IS 4246 will pass all the requirements of categories II_{23} , II_{2HL3} , II_{2HL3} , & II_{2N3} appliances specified in EN 30- 1-1: 2021.

For the purpose of deciding whether a particular requirement of this standard is complied with the final value, observed or calculated, expressing the result of a test or analysis shall be rounded off in accordance with IS 2 : 2022 'Rules for rounding off numerical values (*second revision*)'. The number of significant places retained in the rounded off value should be same as that of the specified value in this standard.

Draft Indian Standard

**DOMESTIC GAS STOVE & BUILT IN HOB FOR
USE WITH LPG — SPECIFICATION**

(*Sixth Revision* of IS 4246)

1 SCOPE

1.1 This standard specifies construction, operation, safety requirements and tests for domestic gas stoves and Built in hobs with corrosion resistant or non-corrosive metallic bodies, corrosion resistant or non-corrosive metallic or plastic frame with glass top intended for use with liquefied petroleum gas at 2.942 kN/m² (30 gf/cm²) gas inlet pressure.

1.1.1 For convenience, this standard has been divided into three sections as follows:

Section 1 Construction

Section 2 Performance

Section 3 General

2 REFERENCES

The standards at Annex A contain provisions which, through reference in this text, constitute provision of this standard. At the time of publication, the editions indicated were valid. All the standards are subject to revision, and parties to agreements based on this standard are encouraged to investigate the possibility of applying the most recent editions of the standards.

3 TERMINOLOGY

For the purpose of this standard, in addition to the definitions given in IS 6480, **3.1** shall also apply.

3.1 Built-in Hobs — Appliance intended to be installed in a cabinet/ cutout in counter top or unit which can be also converted to a freestanding with closed bottom sheet by adding feet

SECTION 1 CONSTRUCTION

4 GENERAL

4.1 In addition to the relevant requirements given in 4 of IS 5116, the requirement given in **4.1.1** shall apply.

4.1.1 No pressure regulator shall be included as a part of the stove/ Built in hobs.

5 MATERIALS

The relevant requirements given in 5 of IS 5116 shall apply.

5.1 Surface of Glass or Glass Ceramic

5.1.1 Toughened glass, if provided, shall meet the following requirements.

- a) Compliance as per IS 2553 (Part 1);
- b) The thickness of the glass shall be minimum 5.7mm;
- c) Toughened glass top including their edges or corners shall not have fissures or scratches;
- d) The toughened glass should withstand thermal shock when tested as per Annex C-1.1;
- e) An adhesive tape of minimum thickness as 0.10 mm, shall be pasted on toughened glass with no visible wrinkles;
The adhesive tape shall not burn or peel off when tested as per Annex **C-1.2**;
- f) The following instructions for safe use of glass top gas stove/built in hob shall be printed on the toughened glass. The instructions shall be properly readable. Instructions shall also be printed in the instruction manual provided;
 - 1) Bati/tandoor/inverted vessel or similar utensils may be used only with bati stand provided with the glass top gas stove/built in hob;
 - 2) Do not pour water on the glass when it is hot;
 - 3) Do not keep hot vessels on the glass surface;
 - 4) Do not hammer the glass
- g) The means used to hold the glass top of the gas stove/built in hob shall not allow any stress or risk of mechanical change to the glass top. For example, screws used for assembly shall not come into contact with glass top.
- h) The distance between flat bottom of vessel and glass top shall be such that the temperature of the glass does not exceed 200°C when tested with Vessels having diameter suitable to cover the pan supports duly filled with water and placed on all the burners of the appliances. The temperature measured during 30-minute duration test may not exceed 200 °C. The temperature shall be measured with a suitable thermocouple system.
- j) A Bati stand may be provided as part of toughened glass gas stove/built in hob for making Bati, Tandoor or inverted vessel preparation etc. The design of the Bati stand shall be such that, it meets with the requirement of **5.1.1** (h) above. The design referred as Fig. 1 is only for reference. Any other design may be used, provided the condition of temperature of glass given above is satisfied.

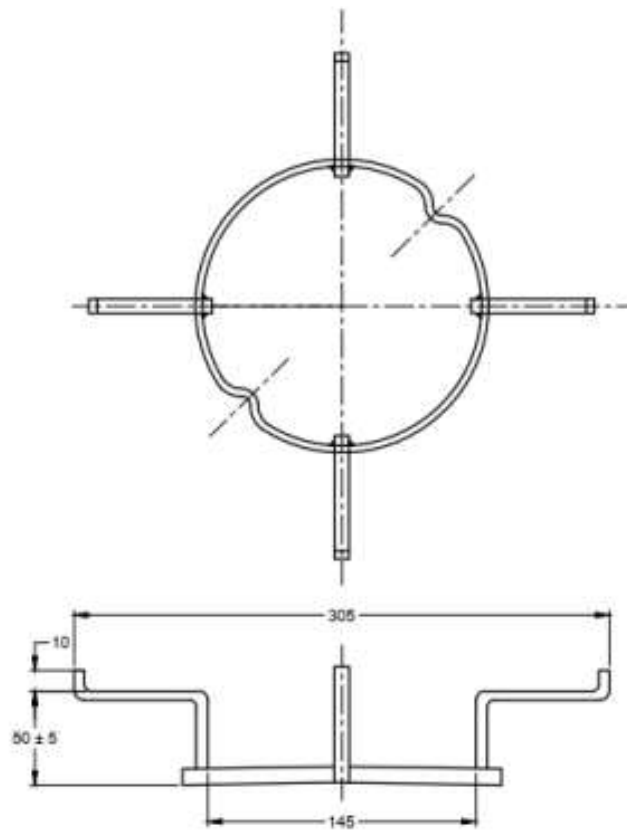

All dimensions in millimeters.

FIG. 1 REFERENCE FIGURE FOR BATI/INVERTED VESSEL/TANDOOR STAND

6 DESIGN FOR MAINTENANCE

6.1 The appliance, including all the component parts, shall be easy access to the accessories and controls for maintenance and adjustment.

6.2 The parts of the burner shall not become disconnected during operation of the appliance. The burners should be so spaced that the relative distance between the centers of the adjoining burner shall not be less than 180 mm.

6.3 Burner ports shall be so designed and located that in normal use spillage of food shall not cause internal fouling of mixing tube and/or blockage of injector jet.

6.4 Burners and parts of burners only of same rating model and make, shall be interchangeable or replaceable without effecting performance.

6.5 Parts, which are intended to be removable by the user, shall be easy to replace correctly, and difficult to assemble incorrectly.

6.6 All nuts, bolts and fittings having spanner flats shall be capable of being moved by suitable spanner or be readily accessible to an adjustable spanner.

6.7 Auto ignition system operating on electricity should meet with the requirement of **6.7** of IS 5116. This requirement will not be applicable for battery operated auto ignition.

7 RIGIDITY AND STABILITY

7.1 The appliance shall be so designed that it remains stable and shall not be easily overturned.

7.2 The appliance, if mounted on a cylinder or on a stand shall be so designed that it will not tip over when placed on a plane at an angle of 10° from the horizontal, with the container empty.

7.3 When the appliance is mounted on the cylinder, it should be disconnected from such cylinder and installed on a flat platform to complete the type testes as per **27** (a).

7.4 A schematic diagram enclosed



FIG. 2 REFERENCE FIGURE FOR APPLIANCE MOUNTED ON CYLINDER

8 WORKMANSHIP AND FINISH

8.1 In addition to the relevant requirements given in **7** of IS 5116, the requirements given in **7.2** and **7.3** shall apply.

8.2 The external finished surfaces shall be easily cleanable.

8.3 Except for burners, all other parts, namely, springs, screws, bolts and nuts, pipes, pins, etc., which are visible and can be removed for maintenance shall be of corrosion resistant material or treated to resist corrosion appropriate to the conditions of use.

9 GAS TAPS

9.1 The relevant requirements given in **8** of IS 5116 shall apply except **8.7** and **8.11.1**. Simmer flame shall be obtained by fixed or variable simmer orifice.

10 INJECTOR JETS

The injector jets shall be fixed calibrated type and it shall not be possible to loosen them without the use of tools. The dimensions of the injector jet shall conform to the following requirements:

Across flats	6 mm, Minimum
Projection from the face of mounting	3 mm, Minimum
Threads	M5, 1BA or M6

11 BURNERS

11.1 In addition to the relevant requirements given in **10** of IS 5116, the requirements given in **11.2**, **11.3** and **11.4** shall apply.

11.2 For burners having centre flame, provision shall be made to protect the centre flame from pans resting directly on burner top and smothering the centre flame. Alternatively, a loose pan support should be provided to avoid the pan directly resting on burner.

11.3 The appliance comprising two or more burners shall include one burner having a rating of at least 1490 kcal/h, based on net calorific value, (when using commercial LPG).

11.4 The burners of Built in Hobs essentially shall be closed type i.e., it should not allow spillage to fall inside the body of the appliance.

12 BURNER PAN SUPPORTS

12.1 The design of the pan supports shall be such that it is practicable to support a pan of 100 mm diameter, over at least one top burner without the use of loose rings, and such that 125 mm diameter vessel remains stable over each burner. Prongs of the support shall have suitable taper to accommodate round bottom pans.

12.2 Loose pan supports shall be so designed that it is not possible to place them firmly in other than proper position.

12.3 The design of the pan support shall be such that the assembly will remain stable when used with flat vessel of diameter from 150 mm to 250 mm.

13 GAS SOUNDNESS

13.1 The relevant requirements given in **16** of IS 5116 shall apply.

13.2 Alternatively, for gas soundness checking any suitable digital instrument with an accuracy of 0.01 l/hr can be used. Any leak detected during each of the tests shall not exceed 0.06 l/hr'.

13.2 Gas Leak Detector

13.2.1 The stove/built in hob may be provided with a gas leak indicator. If gas leak indicator is provided, it shall conform to the requirements of IS 13432 (Part 1).

14 GAS INLET CONNECTIONS

14.1 In addition to the relevant requirements given in **18** of IS 5116, the requirements given in **14.2** and **14.7** shall apply.

14.2 The position of the gas inlet shall allow connection to a gas supply on either side of the appliance. Inlet connection at the rear or bottom is also permitted. It shall be possible to change gas inlet from one side to other side easily by standard tools. Revolving Nozzle may be used to fit on any side of the gas stove/built in hob.

14.3 Nozzles shall be made from brass, zinc alloy, mild steel or aluminum alloys.

14.4 Where nozzles for flexible tubing are fitted, they shall be so positioned as to facilitate fitting of the tubing and also to prevent heating of the tubing to more than 60 °C.

14.5 Screwed gas inlet and outlet connections shall have threads specified in **17.3** of IS 5116.

14.6 The pipe/tube used for main gas rail shall be metallic. The wall thickness of main gas rail other than the threaded portion to be maintained shall be 1.25 mm (+ no limit/ -0.25 mm) in case the gas taps are connected with gas rail through threaded bushes. The wall thickness of main gas rail (other than threaded portion) to be maintained shall be 0.9 mm (+ no limit/ - 0.09 mm) when the gas taps are connected with gas rail with clamps. The external surface of the gas rail shall be treated to resist corrosion. Any other connection made from the main gas rail shall be only metallic.

15 STRENGTH AND RIGIDITY

For metallic body, when tested as specified in Annex B, the vertical resultant deflection of the top surface measured at the center of length of the body, shall not exceed 2 mm and the distance between the opposite sides (lengthwise and widthwise) shall not change by more than 5 mm. This test shall be applicable for metallic body gas stoves only.

SECTION 2 PERFORMANCE

16 GENERAL CONDITIONS OF TEST

The relevant requirement given in **19** of IS 5116 shall apply.

17 GAS CONSUMPTION

17.1 Each Burner assembly under separate 'ON/OFF' control shall give ± 8 percent of the manufacturers' specified gas consumption in l/h or heat input in kcal/h at 2.942 kN/m² (30 gf/cm²) gas inlet pressure when measured by volumetric method with a wet gas meter using compressed air (27 °C and 760 mm mercury). Thereafter using 0.75 as multiplying factor, the value of air flow at STP so obtained to be converted to flow of LPG at STP.

NOTE — For this test, one liter of LPG = 2.46 g.

$$\text{Correction factor} = \frac{(H + 22.06 - v)(300)}{760 (R. T. + 273)}$$

where

- H = Barometric Height in mm of mercury
22.06 = Equivalent mercury column of 300 mm water column
V = Water vapour at room temperature.
300 = (STP temperature + 273) in Kelvin
RT = Room temperature when checked from the thermometer of gas flow meter.

17.1.1 When tested for gas consumption, the apparatus shall be setup as given in Annex D. The measurement of volume shall be made with a wet gas flow meter and with minimum consumption of 6 litres or volume displacement of two revolutions of the drum whichever is higher.

17.1.2 Multi burner appliances (namely, appliances having more than one burner) shall give within +5 and -15 percent of the declared total gas consumption in g/h or heat input in kcal/h at 2.942 kN/m² (30 gf/cm²) gas inlet pressure with commercial LPG and with all the taps turned on.

17.2 For Gas Stoves — It shall be possible to reduce the maximum consumption rate of the burner to the extent given below or lower by providing a fixed simmer orifice in the gas tap:

- a) For burners upto 60 l/h gas rate, 40 percent or 22 l/h of the rated capacity whichever is higher;
- b) For burners above 60 l/h to 80 l/h gas rate, 30 percent or 26 l/h of the rated capacity whichever is higher; and
- c) For burners above 80 l/h gas rate, 30 percent or 28 l/h of the rated capacity whichever is higher.

For Built in Hobs — Multi burner appliances (namely, appliances having more than one burner) shall give within + 5 and -15 percent of the declared total gas consumption in g/h or heat input in kcal/h at 2.942 kN/m² (30 gf/cm²) gas inlet pressure with commercial LPG and with all the taps turned on. It shall be possible to reduce the maximum consumption rate of the burner to 50 percent of the rated capacity by providing a fixed or variable simmer orifice in the gas tap.

17.2.1 Burner with a gas rate of up to 20 l/h at 2.942 kN/m² (30 gf/cm²) gas inlet pressure and appliances incorporating piezo-electric ignition shall, however, be exempted from **17.2**.

17.2.2 When the gas consumption of a burner is reduced to simmer as described in **17.2**, the flame shall not extinguish, blow off, strike back or form soot when tested with commercial LPG at 2.942 kN/m² (30 gf/cm²) gas inlet pressure.

18 IGNITION AND FLAME TRAVEL

18.1 There shall be easy and safe access for lighting and relighting each burner by a match stick and it shall be easy to see that the burner is lighted. Where the burner or burners are lighted by a pilot flame, it shall not be possible for gas to be admitted to the main burner without being smoothly ignited by the pilot flame. Each burner should be at room temperature at the beginning of the test and should be tested in turn.

18.2 If a flame is applied to any of the outer row of the burner ports when the gas is flowing, flame travel shall be complete. This applies for the all pressures from 2.452 to 3.432 kN/m² (25gf/cm² to 35 gf/cm²), taps being fully opened and without a pan over the burner.

18.3 When the burner is ignited from a pilot flame and / or by an electric/electronic method, the ignition and flame travel shall be smooth at pressure from 2.452 kN/m² to 3.432 kN/m² (25 gf/cm² to 35 gf/cm²) with the burner tap turned full 'ON' and ignition shall be effected without undue delay after turning on taps.

18.4 When flame failure devices are used, it shall conform to **14** of IS 5116.

19 FLAME STABILITY

19.1 It shall be possible to operate the appliance with taps fully open at gas inlet pressure from 2.452 kN/m² to 3.432 kN/m² (25 gf/cm² to 35 gf/cm²) without the flame extinguishing, blowing off or striking back and without the formation of soot.

19.1.1 When the gas consumption of a burner is reduced to simmer after operating for half an hour at full 'ON', the flame shall not extinguish, blow off, strike back or form soot when tested with commercial LPG at 2.452 kN/m² (30 gf/cm²) gas inlet pressure.

19.2 Pilot flames shall be stable, without lifting or soot deposition, at gas inlet pressure from 2.452 kN/m² to 3.432 kN/m² (25 gf/cm² to 35 gf/cm²).

19.3 The fixed minimum pilot rate shall be sufficient to relight the main burner at 2.452 kN/m² (25 gf/cm²) gas inlet pressure.

20 NOISE CONTROL

The ignition of the burner flames, their operation and turning 'OFF' shall not give rise to undue or excessive noise during all the operations.

21 FLASH BACK

21.1 A vessel having diameter suitable to cover the pan supports duly filled with water, shall be placed on the burner under test. The tap of the burner shall be turned 'ON' and gas shall be allowed to flow through the burner at full rate, with taps fully opened and gas lighted. After half an hour, the flame shall be immediately reduced to simmer and then brought back to full size. The operation shall be repeated five times. No flash back shall occur during the test. This applies for all pressures from 2.452 kN/m² to 3.432 kN/m² (25 gf/cm² to 35 gf/cm²). Suitable flame control valve which will allow unidirectional flow of LPG towards burner can also be used.

22 FORMATION OF SOOT

22.1 A vessel, 150 mm diameter, full of water, shall be placed on the burner and the burner lighted at Full 'ON' position of the tap for one hour. After the test, no soot (unburned carbon) shall be deposited on the burner and on the bottom of the vessel. This applies for all pressures from 2.452 kN/m² to 3.432 kN/m² (25 gf/cm² to 35 gf/cm²).

23 RESISTANCE TO DRAUGHT

23.1 There shall be no extinction of the flames on any of the burners operating at maximum consumption when the appliance is placed for minimum 30 second in a general (not localized) current of air with a velocity of 2 m/s, as measured with a rotating vane anemometer. The location of the appliance relative to neighboring walls and the direction of the draught shall be varied to correspond to likely conditions of appliance installation. This applies for all pressures from 2.452 kN/m² (25 gf/cm² to 35 gf/cm²).

24 COMBUSTION

24.1 When tested according to the method laid down in Annex E, on no account the carbon monoxide/ carbon dioxide ratio of the exhaust gases of any burner, operating at any consumption at which the burner is stable at gas inlet pressure from 2.452 kN/m² to 3.432 kN/m² (25 gf/cm² to 35 gf/cm²), exceed 0.02. It shall also be possible to obtain the required carbon monoxide/carbon dioxide ratio with the pan supports reversed or put in any other possible position or with a large skirted vessel placed over any burner. This test need not be performed on burners with a gas rate of less than 20 l/h at 2.942 kN/m² (30 gf/cm²) gas inlet pressure.

24.2 The carbon dioxide and carbon monoxide content of the products of combustion shall be determined by the methods capable of giving accuracy of 0.5 percent and 0.001 percent, respectively, of the volume of the sample.

25 FIRE HAZARD AND LIMITING TEMPERATURES

25.1 In addition to the relevant requirements given in **23** of IS 5116, requirements given in **25.2** shall apply.

25.2 With burner lighted at full 'ON' position, the temperature of the flame at any point in a plane at a height of $H + 20$ mm from the top of the pan support shall not exceed 500 °C, H is the pan height corresponding to the gas rate of the burner as shown in col 3 of Table 1 under Annex F. This test shall be performed on each burner. Thermocouple made from 0.5 mm diameter wire and placed in the center of stainless steel tube having outside diameter 10 mm *Max* and closed at the end along with temperature indicator shall be used for the measurement of the temperature.

26 THERMAL EFFICIENCY

26.1 For Gas Stoves — When tested as specified in Annex F, the thermal efficiency shall be minimum 68 percent for each burner of gas stove with the pan placed correctly on the pan supports. For this test, the net calorific value of the gas shall be employed. If this is not determined experimentally, the value may be taken as 10 900 kcal/kg for calculation. Thermal efficiency may be declared for a batch production, if it is 72 percent and above as verified by BIS.

26.2 For Built in Hobs — When tested as specified in Annex F, the thermal efficiency shall be minimum 55 percent for each burner of built in hob with the pan placed correctly on the pan supports. For this test, the net calorific value of the gas shall be employed. If this is not determined experimentally, the value may be taken as 10 900 kcal/kg for calculation. Thermal efficiency may be declared for a batch production, if it is 60 percent and above as verified by BIS.

27 CLASSIFICATION OF TESTS

27.1 Type Test

The following shall constitute type tests:

- a) Strength test (*see 15*);
- b) Gas consumption (*see 17*);
- c) Flashback test for materials of burners (*see 5.2* of IS 5116);
- d) Formation of soot (*see 22*);
- e) Resistance to draught (*see 23*);
- f) Combustion test (*see 24*);
- g) Fire hazard and limiting temperature (*see 25*);
- h) Floor, wall, ceiling and surface temperature (*see 23.1* and *23.2* of IS 5116); and
- j) Thermal efficiency (*see 26*).

27.2 Routine Tests

The following shall be carried out as routine tests:

- a) Gas soundness (*see 13*);
- b) Ignition and flame travel (*see 18*);
- c) Flame stability (*see 19*);
- d) Noise control (*see 20*);
- e) Flash back (*see 21*); and

SECTION 3 GENERAL

28 INSTRUCTIONS

28.1 The appliance shall be accompanied by an instruction card giving the following information:

- a) Brief instructions for installation and regulation which include piping and fitting of terminal, if any;
- b) Rating of the burners in kcal/h and in g/h (with commercial LPG);
- c) Instructions for the correct operation of the appliance;
- d) Country of origin;
- e) The words 'For use with commercial LPG at 2.942 kN/m² (30 gf/cm²)'; and
- f) Thermal efficiency may be declared, if it is 72 percent and above for Gas stoves and/or 60% and above for Built in Hobs as verified by BIS.

29 MARKING

29.1 Each appliance shall be legibly and indelibly marked with the following:

- a) Manufacturer's name and/or initials or registered trade-mark;
- b) Total gas consumption in g/h (with commercial LPG);
- c) Rating of the burners in kcal/h and in g/h (with commercial LPG);
- d) Any special instructions for the safe use of the appliance;

- e) The words 'For use with commercial LPG at 2.942 kN/m² (30 gf/cm² approximately)':
- f) Country of origin; and
- g) Thermal efficiency may be declared, if it is 72 percent and above for Gas stoves and/or 60% and above for Built in Hobs as verified by BIS.

29.2 BIS Certification Marking

29.2.1 The Gas stoves/Built in hobs may also be marked with the Standard Mark.

29.2.2 The use of Standard Mark is governed by the provisions of the *Bureau of Indian Standards Act, 2016* and the rules and regulations made thereunder. The details of conditions under which a license for the use of the Standard Mark maybe granted to manufacturers or producers may be obtained from Bureau of Indian Standards.

30 PACKAGING

The gas stoves/Built in hobs shall be packed as agreed to between the purchaser and the supplier, taking care of safety requirements as such during handling and transit to protect against damages.

ANNEX A
(Clause 2)

LIST OF REFERRED INDIAN STANDARDS

<i>IS No.</i>	<i>Title</i>
IS 1070 : 2023	Reagent Grade Water Specification (<i>fourth revision</i>)
IS 2553 (Part 1) : 2018	Safety glass — Specification : Part 1 Architectural, building and general uses (<i>fourth revision</i>)
IS 5116 : 2020	General requirements for domestic and commercial equipment for use with LPG (<i>fourth revision</i>)
IS 13432 : 2023	Mechanical Type Gas Leak Detector for use with Low Pressure Liquefied Petroleum Gas Burning Appliances — Specification (<i>first revision</i>)
IS 14900 : 2018	Transparent flat glass — Specification (<i>first revision</i>)

ANNEX B
(Clause 15)

STRENGTH AND RIGIDITY TEST

B-1 PROCEDURE

B-1.1 The rubber support (grommet) if any, shall be removed and replaced with identical metal supports. If the material of the legs is other than hard rubber, the test shall be carried out with the original legs in place. The pan support and burner shall be removed and the distance between the sides of the appliance body being tested shall be measured.

A reference reading at the top surface of the body at the centre of the width shall be taken. A load of 250 N (25 kg) per burner shall be applied at the top surface subject to a minimum load of 500 N (50 kg) for a single burner stove. The load shall be applied without impact to a strip of steel having 20 mm thickness, 100 mm width and as long as the length of the appliance (*see Fig. 2*). This strip shall be placed in the centre of the top surface of the appliance and its length parallel to the front. The load shall be maintained for five minutes after which the measurement for deflection at top surface of body (at the centre of the width just in front of the strip) shall be taken with the load in position.

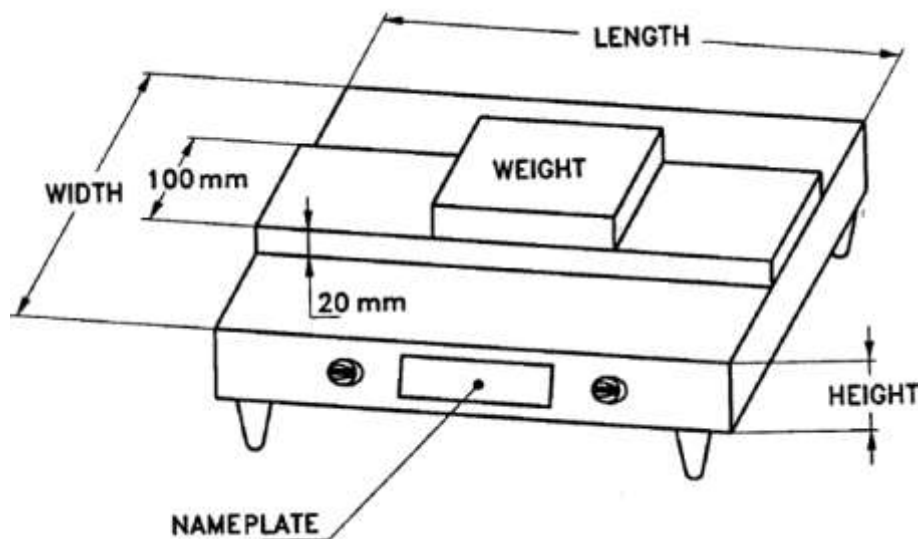

FIG. 2 STRENGTH TEST

ANNEX C
[Clause 5.1.1 (d and e)]

THERMAL SHOCK TEST

C-1 PROCEDURE

C-1.1 Vessels having diameter suitable to cover the pan supports duly filled with water shall be placed on all the burners of the appliance. The taps of the burners shall be turned on and gas shall be allowed to flow through the burners at full rate. After 30 minutes turn off all the taps. Pour one-liter water at a temperature of $15 \pm 5^{\circ}\text{C}$ steadily and uniformly on the glass surface. This glass should not chip, crack or break.

C-1.2 Check the adhesive tape pasted on the glass, it should not burn or peel off.

ANNEX D
(Clause 17.1.1)

GAS CONSUMPTION TEST

D-1 PROCEDURE

D-1.1 The stove/built in hob shall be set in accordance with 16 with the addition of a suitable device for measuring gas consumption. The wet gas meter, which is an instrument commonly used for this purpose, shall be set up in series with stove/ built in hob under test (*see Fig. 3*).

D-1.1.1 Clean and dry air shall be passed at 2.942 kN/m^2 (30 gf/cm^2) inlet pressure through the stove/ built in hob for a few minutes to purge the system of air and to establish the gas pressure required. Only one burner of the appliance shall be tested at a time and during the test all gas delivered to the stove/ built in hob shall flow through the jet of the burner being tested.

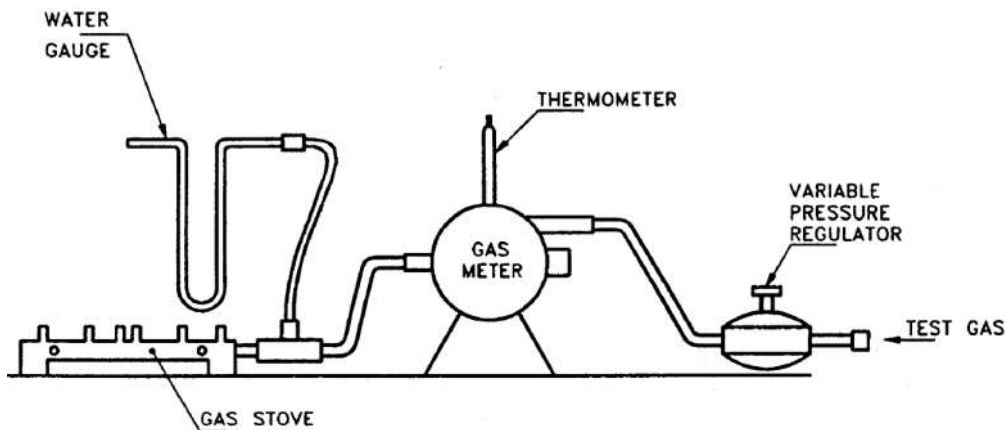

FIG. 3 TEST SET-UP FOR GAS CONSUMPTION

ANNEX E
(Clause 24.1)

**TEST METHOD FOR DETERMINATION OF CARBON
MONOXIDE/CARBON DIOXIDE RATIO**

E-1 PROCEDURE

E-1.1 The appliance shall be set-up in accordance with 16. Before starting the test, a pan of 190 mm diameter and of suitable height and containing water sufficient for the test shall be placed over the burner. In addition, a collecting hood (see Fig. 4) suitable for the burners under examination shall be obtained.

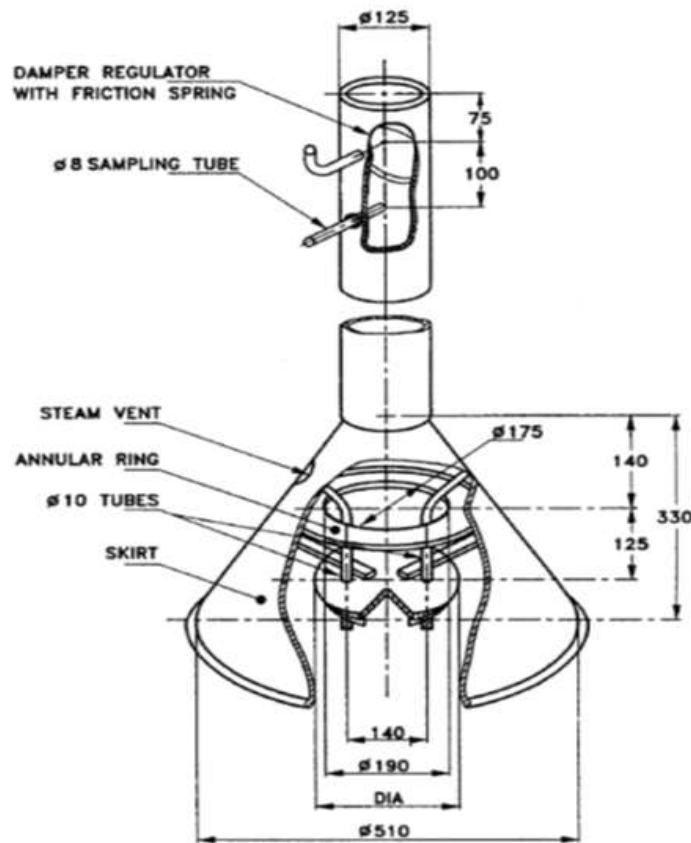

(All dimensions in millimeters)

FIG. 4 HOOD FOR BURNER

E-1.1.1 The hood shall be so designed that, while not interfering in any way with the normal combustion of the burner, it collects a fairly high proportion of the products of combustion. Also, it shall be such that the sample collected represents the whole of the combustion gases and not those from any particular point.

When using this hood, the damper provided shall be set or additional flue pipe added, so that spillage of the flue gases around the skirt is just prevented. With the sample hood in position over the burner under investigation, gas at inlet pressure of 2.452 kN/m^2 (25 gf/cm^2) shall be admitted and the burner operated for a 5 to 10 minutes till the steam is out before sampling commenced. The reason for this being that during the first 5 to 10 minutes the burner is warming up and the proportion of carbon monoxide may be high. However, this is not dangerous provided the burner works satisfactorily after heating up.

E-1.2 Any of the recognized methods having the prescribed accuracy may be used for gas analysis. For carbon monoxide, it is recommended that co-indicator of prescribed accuracy or iodine pentoxide method or catalytic method, for example, Dragger method, the Katz method or infrared analysis methods may be used. Carbon dioxide may be tested with an Orsat apparatus, the Haldane apparatus or by infrared analysis.

E-1.3 Each burner shall be examined with gas at 2.452 kN/m^2 to 3.432 kN/m^2 (25 gf/cm^2 to 35 gf/cm^2) inlet pressure. It shall also be noted that each burner is tested separately or with all the possible combination of the other burners operating.

ANNEX F
(Clause 26)

THERMAL EFFICIENCY TEST

F-1 PROCEDURE

F-1.1 The test shall be carried out by weighing the gas used. The gas shall be taken from a small cylinder containing LPG weighing up to 5kg”, keeping accuracy of balance to measure gas same as 0.1g. The bottle shall be fitted with an ‘On/Off’ valve and shall be connected to a regulator which, in turn, shall be connected to a pressure gauge and to the appliance. A second ‘On/Off’ gas valve shall be inserted in the gas ways upstream of the regulator as near as possible to the gas bottle. A typical layout of set-up necessary for this test is shown in Fig. 5.

F-1.2 The gas shall be passed at 2.942 kN/m² (30 gf/cm²) inlet pressure through the stove/ built in hob for 15 seconds to purge the system of air and to establish the gas pressure required. Only one burner of the appliance shall be tested at a time and during the test all gas delivered to the stove/ built in hob shall flow through the jet of the burner being tested. The pan shall be selected and loaded in accordance with the requirements given in Table 1 and placed centrally over the burner being tested. The temperature of the water t_1 contained shall be noted and recorded as long as it remains constant. The bottle shall be disconnected, weighed, reconnected and valves (1) and (2) opened. The gas control tap shall then be opened and the gas shall be ignited. The water shall be allowed to warm up to about 80 °C when stirring is commenced and continued until the end of the test. The burner shall be put off when the temperature of water reaches 90 °C ± 1 °C. The stirring shall be continued and the maximum temperature t_2 shall be noted.

Next, the valves on the bottle and the gas line shall be closed and the bottle shall be disconnected and re-weighed. It is thus possible to estimate the mass of gas used during the period taken for the water to heat up. Thermal efficiency shall be calculated by the following formula:

$$E = \frac{100 (G + W)(t_2 - t_1)}{MK}$$

Where

- E = thermal efficiency of the burner in percent,
- G = quantity of water in the vessel in kg,
- W = water equivalent of the vessel complete with stirrer and lid,
- t_2 = final temperature of water in °C,
- t_1 = initial temperature of water in °C,
- M = gas consumption in kg, and
- K = Actual Calorific value of the gas in kcal/kg alternatively 10900 kcal/kg.

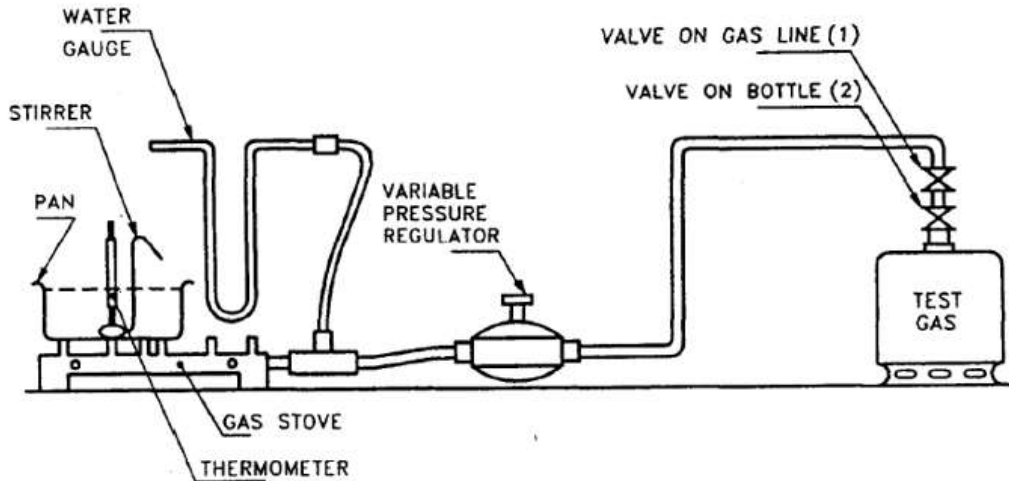

FIG. 5 TEST SET-UP FOR THERMAL EFFICIENCY BY WEIGHT

Table 1 Aluminium Pans for Thermal Efficiency Test (Clause 25.2 and E-1.2)				
Gas Rate at STP	Pan Diameter (External)	Pan Height (External)	Total Pan Mass With LID	Mass of Water in Pan
l/h (1)	mm ± 5% (2)	mm ± 5% (3)	g ± 10% (4)	kg (5)
Up to 40	180	100	356	2.0
41-50	205	110	451	2.8
51-60	220	120	519	3.7
61-70	245	130	632	4.8
71-80	260	140	750	6.1
81-95	285	155	853	7.7
96-107	295	165	920	9.4
<p>NOTES</p> <p>1 Distilled water (see IS 1070) shall be used for test.</p> <p>2 The pan shall be cylindrical with flat bottom.</p> <p>3 The finish of the pan bottom from inside shall always be bright.</p> <p>4 Above 107 l/h, pans shall be specially constructed to conform, as far as possible, with the principles used in formulating this table.</p>				

F-2 In performing the thermal efficiency test, the following points shall be noted:

- a) The set-up shall be carefully checked for leak, before and after the test. If a leak is found after the tests, the results should be cancelled and the test repeated;
- b) The room shall be free from draught;
- c) The initial temperature of the room shall be between 25 °C and 30 °C. The water temperature shall be within ± 2°C of the actual room temperature;
- d) The net calorific value of gas is used. If this is not determined experimentally, the value may be taken as 10 900 kcal/kg for calculation;
- e) At the start of the test, the burner shall be at room temperature;
- f) The temperature of the water shall be measured by means of a device of at maximum 0.5 °C accuracy the sensitive part of which is immersed to half the depth of the water in vessel

Doc: MED 23(27077)WC
December 2024

- g) Stirring shall be effected by means of a horizontal loop of 3 mm metal rod attached to an upright, which passes through a 6 mm, hole drilled in lid;
- h) This test need not be performed on burners with a gas rate of less than 20 l/h at 2.942 kN/m² (30 gf/cm²) inlet pressure;
- j) Accuracy of weighing balance used shall be of 0.1 g for consumption measurement and 1 g for other weights;
- k) Specific heat of aluminium is 0.214; and
- m) For conducting thermal efficiency test, gas from the commercial cylinder (bottle) of LPG, the first two-thirds of which has been allowed to evaporate (to waste or in vapour withdrawal use), the remaining one-third shall be used for test. The use of last 1 or 2 kg of gas shall be avoided as this may contain heavy ends.