

**BUREAU OF INDIAN STANDARDS****DRAFT FOR COMMENTS ONLY**

*(Not to be reproduced without the permission of BIS or used as an Indian Standard)*

**भारतीय मानक मसौदा**

**द्रवित पेट्रोलियम गैसों के साथ उद्योग के लिए व्यावसायिक  
कुकिंग रेंज सहित ग्रिलर — विशिष्टि**

*( आई एस 8251 का पहला पुनरीक्षण )*

**Draft Indian Standard**

**COMMERCIAL COOKING RANGES INCLUDING GRILLERS FOR  
USE WITH LIQUEFIED PETROLEUM GASES — SPECIFICATION**

*( First Revision of IS 8251 )*

ICS 27.060.10

---

Domestic And Commercial Gas Burning  
Appliances Sectional Committee, MED 23

Last date for receipt of  
comments is : 09 March 2024

---

**FOREWORD**

*(Formal clause would be added later on)*

This standard is one of a series of Indian Standards on various domestic and commercial gas-burning appliances (pressure type) used with Liquefied Petroleum Gases (LPG). IS 5116 is a necessary adjunct to this standard. Should, however, any deviation exists between the requirements given in IS 5116 and those of this standard, provisions of the latter shall apply.

This standard supersedes IS 8251 : 1976 and IS 14612 : 1999 After the publication of this standard, IS 8251 : 1976 and IS 14612 : 1999 shall be treated as withdrawn.

This standard was first published in 1967. The present revision has been taken up with a view to incorporating the modifications found necessary as a result of experience gained in the use of this standard. Also, the standard has been brought into latest style and format of Indian Standard and references to Indian Standard wherever applicable have been updated. BIS certification making clause has been modified to align with the revised *Bureau of Indian Standards Act, 2016*. The following major modification have been incorporated in this revision of the standard.

- a) Clause **10.21** 'Types of Burners' has been added with the revision of the IS;
- b) Scope of Clause **11, 31, 31** and **33** has been widened;

- c) Test method for combustion has been added in Annex B; and
- d) Annex C ‘Method for measurement of Top section Thermal Efficiency’ has been changed.

The composition of the Committee responsible for the formulation of this standard is given at (*to be added later*).

For the purpose of deciding whether a particular requirement of this standard is complied with the final value, observed or calculated, expressing the result of a test or analysis shall be rounded off in accordance with IS 2 : 2022 ‘Rules for rounding-off numerical values (*second revision*)’. The number of significant places retained in the rounded-off value should be same as that of the specified value in this standard.

## 1 SCOPE

**1.1** This standard specifies construction, operation, safety requirements and tests for commercial cooking ranges including grillers having a total gas consumption of more than 500 g/h, intended for use with Liquefied Petroleum Gases at 147.100 kN/m<sup>2</sup> gas inlet pressure (1 500 gf/cm<sup>2</sup>).

**1.2** For convenience, this standard has been divided into three sections as follows:

Section 1 Construction

Section 2 Performance

Section 3 General

## 2 REFERENCES

The standards listed below contain provisions which, through reference in this text, constitute provisions of this standard. At the time of publication, the editions indicated were valid. All standards are subject to revision, and parties to agreements based on this standard are encouraged to investigate the possibility of applying the most recent editions of the standards listed below. In case the standards are to be referred in this clause they are to be listed as follows:

<i>IS No</i>	<i>Title</i>
IS 6480 : 2023	Terms Relating to Domestic and Commercial Gas Burning Appliances — Glossary ( <i>second revision</i> )
IS 5116 : 2020	Domestic and Commercial Equipment for Use with LPG — General Requirements ( <i>fourth revision</i> )
IS 6603 : 2001	Stainless Steel Bars and Flats — Specification ( <i>first revision</i> )

## 3 TERMINOLOGY

**3.1** For the purpose of this standard, the relevant definitions given in IS 6480 shall apply.

## SECTION 1 CONSTRUCTION

## **4 GENERAL**

In addition to the relevant requirements given in Section 1 of IS 5116, the requirements given in **4.1** to **4.3** shall apply.

**4.1** The construction of all parts, whether specifically covered by the various sections of this standard or not, shall be in accordance with the reasonable concepts of safety, substantiality and durability.

**4.2** The general construction and assembly shall be neat with parts well fitted and bolts and other fasteners drawn up tightly to give rigidity. Exposed edges shall be rounded off and all adjustments shall be accessible and easy to operate.

**4.3** No pressure regulator shall be included as a part of the cooking range.

## **5 MATERIAL**

In addition to the relevant requirements of material given in Section 1 of IS 5116, the requirements given in **5.1** apply.

**5.1** Material used in the construction of commercial ranges, unit broilers and open-top broilers shall be suitable for temperature to which they will be exposed during the course of testing under this standard.

**5.2** Non-metallic materials normally in contact with the gas shall not change in weight or volume by more than 15 percent after being immersed in pentane or LPG for 72 h at room temperature when tested according to Annex D of IS 5116.

## **6 DESIGN FOR MAINTENANCE**

In addition to the relevant requirements of design for maintenance given in Section 1 of IS 5116, the requirements given in **6.1** to **6.9** shall apply.

**6.1** Burners, mixers, valves, thermostats, orifices, burner ignition devices, door springs and other accessories and controls which may require cleaning, repair, adjustment or replacement in the field, shall be readily accessible from the front of the appliance for cleaning, adjustment, repair and replacement, without the necessity of disconnecting the appliance from the gas supply. No special tools shall be required for making adjustments. The removal of a manifold panel is permissible.

**6.2** Every part of the appliance shall be of such construction as to be secure against displacement, distortion, warping or other damage and shall be supported to maintain a fixed relationship between essential parts under normal and reasonable conditions of handling and usage. Such parts, not permanently secured shall be designed so that they cannot be incorrectly assembled and cannot be improperly located or misaligned in removing or replacing during cleaning or other servicing.

**6.3** Double coaxial orifices, if used, shall be provided for each main burner, and shall be supplied ready for operation.

**6.4** Construction shall be such that the final burner orifice and primary air adjustments can be made with the burner in place of operation.

**6.5** Ample clearance shall be provided to afford easy manipulation of standard tools when connecting the appliance to the supply piping.

**6.6** The use of oven and broiler burners in one oven shall not be permitted unless the control of these burners is such that they cannot be operated at the same time.

**6.7** Electrical components requiring field adjustment or calibrations shall be readily accessible when the appliance is installed in accordance with the manufacturer's instructions. If operation of the appliance is necessary, to make such adjustments, means for making the adjustment shall be possible without exposing electrical live parts, disturbing wiring and without the necessity of manipulating tools with any burner compartment.

**6.8** By direct or indirect means it shall be possible to ascertain whether each electrically controlled component is functioning with the appliance installed in accordance with the manufacturer's instructions without disassembly of the appliance to a degree which would render it inoperative.

**6.9** Means shall be provided for changing fuses and lamps with the appliance installed in accordance with the manufacturer's instructions without exposing electrically live parts except screws, shells or clips of lamp holders and fuse holders. Partial disassembly for this purpose is permissible provided wiring is not exposed in such a manner as to possibly be damaged or have strain applied to connections during the servicing. The same conditions apply to normal cleaning of the appliance.

## **7 WORKMANSHIP AND FINISH**

In addition to the relevant requirements of workmanship and finish given in Section 1 of IS 5116, the requirements given in **7.1** to **7.5** shall also apply.

**7.1** The general construction and assembly shall be of neat and workmanlike character with parts well fitted and bolts or other fasteners drawn up tightly to give rigidity. Any exposed edges which might reasonably be brought in contact with the hand during normal usage or adjustment shall be smooth.

**7.2** The cooking range shall be so designed that it remains stable and shall not be easily overturned.

**7.3** Any rack or baking tray fitted in the oven of the cooking range shall not tip down excessively if it protrudes from the oven for 2/3 of the way and a weight of 10 kg is placed in the middle of it.

**7.4** Construction of appliances having removable bases or detachable legs shall be such that the combustion will not be affected when the legs are detached and the base removed and the appliance is set directly on the floor.

**7.5** Cooking range shall be level and shall not rock when placed on a level surface.

## **8 GAS TAPS**

In addition to the relevant requirements of gas taps, as given in Section 1 of IS 5116, the requirements given in **8.1** to **8.13** shall apply.

**8.1** A separate gas valve shall be provided to control the supply of gas to each burner or group of burners or group of burners operating as a unit. This shall not apply when the appliance is equipped with only one main, burner or group of burners operating as a unit and the manually operated main control valve is located so that it is accessible from the position assumed in igniting the gas at the pilot or main burner(s).

**8.2** Oven and broiler sections provided with indirect control systems, other than electric systems incorporating normally closed valves in the main gas supply line, shall be designed so that the thermostat and main burner gas supply line are under the supervision of a manual shut-off means operatable from the front without removal of panels.

**8.3** Gas valves shall be readily accessible for lubrication, inspection and test and, excepting oven heat control valves, shall be capable of removal without disconnecting the manifold from the gas supply. The simple removal of a concealment plate or a gas valve shall not be considered a cause for failure under this provision.

**8.4** Gas valve lubricants shall be resistant to the action of liquefied petroleum gases.

**8.5** Gas valves of the 'Hi-Low' type embodying a single jet orifice shall not have an 'off' position between the full 'on' and 'simmer' positions.

**8.6** When multipurpose top burner valves are provided on ranges not equipped with automatic top burner ignition, means shall be incorporated in the construction or assembly of such valves to indicate by sound or feel the intermediate 'on' and 'OK' positions.

**8.7** Self-latching valves shall be positive in their action, shall not require for their operation an axial displacement of the plug in contact with the barrel nor application of undue pressure on the plug which might cause the valve to stick; shall permit ready operation with one hand and accessibility to all parts for repair and replacement.

**8.8** Burner valve handles and thermostat dials shall be in good alignment with openings in panels. They shall be located with respect to one another and to adjacent members so that any valve, except interlocking valves, maybe turned freely without interference from any part.

**8.9** Valve handles controlling burners (except pilots) shall rotate in a clockwise direction to close. This provision does not apply to selector-type valves or combination valves.

**8.10** When the valve is exposed to view, lever or tee handles shall be at right angles to the lint of flow when in the 'off' position and parallel when in the 'on' position. If this cannot be done, or if only the valve handle is exposed to view, the 'on' and 'off' position or direction of rotation to open and close shall be clearly indicated.

**8.11** Removable handles shall be constructed so that they cannot be incorrectly attached.

**8.12** The oven burner valve handle, when placed in the top burner manifold in line with the top burner valves, shall be substantially different in shape from the top burner valve handles.

**8.13** The taps of separate pilot valves shall be different from those of the main burner valves by their shape and colour.

## **9 INJECTOR JETS**

In addition to the relevant requirements of injector jets given in Section 1 of IS 5116, the requirements given in **8.1** shall apply.

**9.1** Orifice spuds and orifice spud holders shall be constructed of metal, melting at not less than 425°C.

## **10 BURNERS**

In addition to the relevant requirements of burners specified in Section 1 of IS 5116, the requirements given in **10.1** to **10.20** shall apply.

**10.1** Main burners and mixer tubes shall be properly placed and securely positioned so that the burners will not twist or slide or drop out of position while in service. This shall be accomplished without the use of bolts, cotter pins or screws within the burner compartment. The construction shall be such that the burners cannot be installed in other than their correct position.

**10.2** The design and material used in the construction of burners and their support shall be such that neither the burner nor its support will sag, distort, melt, exhibit appreciable corrosion or damage to any protective coating sufficient to expose the base metal or show leakage of gas during any of the tests specified therein or when the burner is operating and the flame burning within the mixer tube or burner head.

**10.3** Main burners and pilot devices or any assembly thereof shall be easily removable and replaceable through the excess opening without disconnecting threaded joints other than those of a union type. Simple disconnection such as the removal of a readily accessible manifold pipe by disconnecting a union shall be permitted if the appliance is equipped with a manual main control valve located on the inlet side of such a connection. Disconnection, removal and reassembly shall be accomplished without the use of special tools or requiring tool manipulation within the burner compartment.

**10.4** The joints when used in the burner zone or in the burner head of the burner assembly, shall be gas-tight and shall not depend on mechanical strength, primarily for tightness of set screws, cement or other sealing materials except where such joints form part of the port area. The burner head shall be of single casting or the joints shall be welded, brazed, bolted screw, joint construction or of any equally rigid and gas-type construction. The burner assembly from inlet to jet shall be checked at a pneumatic pressure of a minimum of 686 kPa (7 kgf/cm<sup>2</sup>) for leakage.

**10.5** Burners which are made of two or more parts shall have joints between parts made tightly and permanently, and the burners shall be easily removable as one piece. Burners and parts of the burners of same type, make, model and rating shall be interchangeable or replaceable without affecting performance. The parts of the burner shall not become disconnected during operation.

**10.6** Ribbon burners shall be constructed so that the ribbon assembly can be easily removed thoroughly cleaned and easily and correctly reinstalled in the field without the use of special tools.

**10.7** When air shutters are used, burner mixer heads shall have flat faces smoothly finished.

**10.8** When ports are used to accomplish ignition between adjacent rows of ports or adjacent burners. Flame carry-over shall be reflected by more than one series of ports.

**10.9** Bodies of burners (including mixer head, mixer tube, and burner head shall be of substantial and durable construction. They shall be made of metals having melting point above 510°C.

**10.10** Wire gauzes used within the burner shall be made of metals having melting point above 510°C.

**10.11** Ports shall be machined or otherwise accurately made.

**10.12** Bolt holes shall not intersect gas ways unless adequate provision is made to assure permanent gas tightness.

**10.13** Removable burner heads shall fit on the mixer tube in the correct position only and shall be connected so that they will remain in the proper position without the use of set screws.

**10.14** Burners in enclosed compartments which are designed to be lighted through an opening in a plate shall be equipped with a trailer lighter arm, ports of which shall be located directly underneath the opening in a plate used for lighting or with other satisfactory ignition means which will provide ignition of the gas at the burners within 30 seconds after the gas is admitted to them when the oven burner is operating at its thermostatically maintained bypass rate.

**10.15** Lighter arms, if employed, shall be either:

- a) Cast or formed integrally with main burners;
- b) Attached to main burner(s) by either a threaded joint tightly drawn up, or by a machined joint of tight construction permanently secured by riveting, bolting, or by a bolted flange;

- c) Separate burner(s) constructed in accordance with the following:
- 1) The gas supply shall be controlled simultaneously with that of the main burner(s) to be lighted;
  - 2) Readily removable fixed orifice spuds shall be provided for limiting the amount of gas consumed;
  - 3) Adequate protection shall be provided against stoppage from spillovers, falling scale, lint or dirt in normal operation;
  - 4) Design and installation shall be such that the relative position of the lighter arm(s) will remain constant with respect to the pilot and main burner(s). A single bolt and nut, tap bolt, or equivalent removable means used in attaching the lighter arm to each main burner in order to effect compliance with this provision shall not be considered as failure to comply with **10.1**.

**10.16** Any annular openings around the oven or broiler burner mixers, where such mixers pass through the range body or through oven or broiler linings, shall be closed. The construction used shall not interfere with the ready removal of the burner(s).

**10.17** Convenient means shall be provided for observing oven and broiler burner and lighter flame. Outside openings provided only for observation of flames shall be screened or covered with non-inflammable transparent material if the minimum dimension is in excess of 8 mm. Observation openings through the oven bottom shall be considered satisfactory.

**10.18** Means shall be provided for observing some portion of each maintop burner flame during adjustment without removing any part of the cooking top.

**10.19** Means shall be provided for observing some portion of the top section flames during operation without removing any part of the unit.

**10.20** The ports of the main and pilot burners of open-top broilers shall be protected from falling particles and grease drippings.

#### **10.21 TYPES OF BURNERS:**

- a) T22, T35, T50, T78;
- b) M22, M35 T22, M50, M78;
- c) RV, RL;
- d) Model 2, Model 4, G/C, Puffer (roti making) having different sizes and gas consumptions;  
and
- e) Infra radiant.

Normally, the burners are rated at a pressure of 5 psi (34.323 kN/m<sup>2</sup> or 0.35 kgf/cm<sup>2</sup>). The flow rate of the burner shall be declared at this pressure. The thermal efficiency test shall be carried out at this pressure, though the burner is capable of operating up to 1 500 gf/cm<sup>2</sup>.

## **11 BURNER SUPPORTS**



**11.1** Top burner supports shall be such that they will keep the burner(s) fixed rigidly at a uniform distance below the cooking surface. Runner supports shall also secure the burner(s) against side-to-side and front-to-back displacement and prevent the burner(s) from being easily dislodged.

**11.2** Oven burner supports shall be of rigid construction and shall hold the burners so that they lie level and cannot be easily tilted.

**11.3** The support shall not interfere with the burner ports.

**11.4** Sheet-iron oven burner supports shall not be less than 1.12 mm and shall be bolted, riveted or spot-welded in place.

**11.5** Ceramic radiants shall be supported so that they are positioned at a uniform distance from the burner and so that the ceramics will not be dislodged in service.

**11.6** Supports for ceramic radiants shall be of rigid construction and of durable and heat-resistant material. Cast-iron supports shall not be riveted or welded.

**11.7** The burner shall be so fitted/designed that it remains stable and shall not be easily overturned.

## **12 PRIMARY AIR CONTROL**

**12.1** When adjustable means are provided for control of primary air to the main burner(s) they shall be constructed so as to permit adjustment of flames to yellow tips and to lifting, a hard flame or flashback. The range of adjustment of flames from yellow tips to lifting, hard flames or flashback shall be easily obtained and of reasonable magnitude.

**12.2** When air shutters are used, there shall be no openings other than the adjustable openings through which primary air may be entrained. Air shutters shall be of such design that they have not more than two primary air openings each approximating a circular opening near point of closure or be of such design and construction as can be demonstrated to provide equally effective protection against stoppage by lint and dust. Other openings through which the main stream of primary air does not flow, such as around an orifice projection, shall be reduced to a practical minimum so as to have no appreciable effect on the flame characteristics when stopped by lint or other means.

**12.3** Means shall be provided to fix air shutters securely in any desired position. Such means shall be conveniently accessible within the place and in operation and shall be located so as not to interfere adjustment of orifice caps when used.

**12.4** Sheet-metal air shutters shall be of a thickness not less than 0.80 mm. If sheet-metal air shutters are of a thickness less than 1.25 mm, they shall be the outer edges turned and right angles or be otherwise properly reinforced.

**12.5** Air shutters shall have a corrosion-resisting finish, except when the type of material or construction employed will prevent sticking or corroding in position. Cast-iron air shutters are considered to be acceptable.

**12.6** Unit broilers shall have the mixer heads protected or located to prevent contamination of the primary air supply by the broiler cooking vapours.

### **13 BASES, LEGS AND FRAMES**

**13.1** Rand iron, angle iron or other structural shapes used in the construction of bases and frames shall have joints securely riveted or welded together or to the body sides.

**13.2** Cast bases and frames, when not cast in one piece, shall have joints securely fastened to give effectively a one-piece construction.

**13.3** Sheet iron used in the construction of bases and frames shall not be less than 1.25 mm, and edges shall be reinforced, as by folding.

**13.4** Legs shall be rigidly held in place.

**13.5** When legs are provided, suitable levelers shall be provided on appliances designed for battery installation.

**13.6** Commercial ranges shall support, without breakage or apparent damage for a period of 15 minutes, a load of 3.6 kN applied without impact across the centre of the two weakest members of the top of the range tested as given in **13.6.1**.

**13.6.1** The top grates or solid plates shall be removed. A wooden beam 150 mm square shall then be placed across the two weakest members of the top frame at their centres. A load of 3.6 kN shall then be applied without shock at the centre of the beam and the effect is noted.

**13.7** Legs up to 205 mm in height and bases shall be substantial and rigid to the extent that they will not be deformed or damaged by moving the assembled range 0.9 m along a smooth concrete floor endwise or sidewise by pressure exerted in a normal manner against the top end or top side, respectively, sufficient to cause the range to move freely.

### **14 PILOT BURNERS AND SAFETY SHUTOFF DEVICES**

Commercial cooking ranges shall be equipped with a pilot burner and safety shutoff device, In addition to the requirements given in **13** and **14** of IS 5116, the requirements given in **14.1** to **14.12** shall also apply.

**14.1** Burners located in enclosed compartments, except top sections, shall be equipped with a pilot burner and safety shutoff device.

**14.2** Pilot burner and safety shutoff device assemblies having input ratings in excess of 1 046 kJ per hour shall automatically shut off the gas to all burners, including pilot burners, in the event that the means of ignition become inoperative.

**14.3** Pilot burner and safety shutoff device assemblies having input ratings of 1 046 kJ per hour or less need not be of the complete shutoff type.

**14.4** Tips of aerated pilot burners shall be made from stainless steel of designation 30Cr13 of IS 6603 or material having at least equivalent heat and corrosion-resistant characteristics. Nickel alloys of greater than 1.0 percent nickel, because of the catalytic cracking effect, are not acceptable.

**14.5** Fixed primary air openings of blue flame pilot burners shall be of a size that will give a satisfactory flame when using the manufacturer's recommended orifice size for each of the test gases.

**14.5.1** When air shutters are used, there shall be no openings other than the adjustable openings through which primary air may be entrained. Air shutters shall be of such design that they have not more than two primary air openings each approximating a circular opening near point of closure, or be of such design and construction as can be demonstrated to provide quality effective protection against stoppage by lint and dust. Air shutters shall have adequate means for holding them in the desired adjustment position.

**14.6** Pilot burners shall be placed so that they can be easily seen, safely lighted, and readily removed for cleaning.

**14.7** Pilot burner and safety shutoff device assemblies shall be installed so that the ports of the pilot burner and operating mechanism of the safety shutoff device will not be obstructed by falling scale, lint or dirt in normal operation.

**14.8** Pilot burner orifice adjustment means shall be fully accessible for adjustment and servicing. The orifice spud shall be easily accessible for removal and replacement.

**14.9** Pilot burners shall be designed and installed so that the relative position of the pilot and separate lighter arm(s), when employed, or main burner(s) will remain constant. Mounting of the pilot, separate lighter arm, or main burner directly or indirectly on members that may warp in service with resultant misalignment between pilot, separate lighter arm, and the main burner shall not be considered as complying with this provision. A single bolt and nut, tap bolt, or equivalent removable means used in attaching the pilot to the main burner, or to a separate lighter arm, in order to effect compliance with this provision shall not be considered as failure.

**14.10** Provisions shall be made for an adequate supply of air at all times for the combustion of the gases from the pilot burner.

**14.11** When a separate pilot burner is used, the design of the control system shall be such that gas cannot be admitted to the main burner while the pilot burner is being lit and until the safety shutoff device will remain in its normal open position.

**14.12** The temperature of a safety shutoff device during the conduct of the wall and floor temperature test shall not exceed a temperature of 13.5 °C, below the temperature for which the device is designed.

## **15 THERMOSTATS**

In addition to the requirements given in **15** of IS 5116, the requirements given in **15.1** to **15.7** shall apply.

**15.1** Each oven which is classified as being capable of baking or roasting operations shall be equipped with a thermostat.

**15.2** Graduating-type thermostats shall be bypassed to permit a minimum safe gas flow to the main burner(s) with thermostatic valve closed.

**15.3** Oven thermostat dials shall be provided with temperature markings. The thermostat dial for other than oven sections shall be provided with temperature markings or a lettered or numbered scale.

**15.4** The thermostat body temperature shall be limited to 79.5 °C except for those thermostats that are supplied by the thermostat manufacturer for operation at higher temperatures.

**15.5** Thermostat capillary tubes and bulbs for oven and broiler application shall be constructed of steel or material of equivalent durability.

**15.6** Thermal elements and capillary tubes shall be located or protected against mechanical damage in normal use.

**15.7** Indirect oven thermostats incorporating more than one gas supply tube shall be constructed so that tubing cannot be interchanged. General requirements for domestic and commercial equipment for USC with LPG.

## **16 FLUE COLLARS AND FLUE BOXES**

**16.1** A flue collar, when provided, shall serve as an effective vent for all range ovens, closed tops, and canopies. The flue collar shall be of cast iron or of sheet steel of a thickness not less than that of 0.80 mm.

**16.2** A flue collar, when provided, shall be on the top or at the rear of the range and shall be constructed so that the placing of a utensil over the collar will not cause incomplete combustion of the gas nor smothering of burner flames.

**16.3** When the flue collar is located at the rear of the range, the outlet shall look up.

**16.4** Flue collars shall be of such size and shape as to accommodate flue pipe of integral centimetre diameter.

**16.5** Provisions shall be made for the firm support of the draft hood or flue pipe to the flue collar.

**16.6** Adequate means shall be provided to prevent the restriction of the flue way by the attachment of a draft hood or flue pipe to the flue collar.

## **17 DRAFT HOODS**

**17.1** All parts of draft hoods, when provided, shall be constructed of a material having a thickness at least equal to 0.40 mm sheet steel.

**17.2** Removal draft hoods shall be designed so that removal and replacement in normal usage will not permanently deform any part nor alter the relative position of any part with respect to another.

**17.3** Draft hood outlets shall be of such size as to accommodate flue pipe of integral centimetre diameter.

**17.4** A draft hood shall be sufficiently rigid in construction and shall not become distorted when tested by the method given in Annex A and the appliance, is operated at the increased test pressure.

## **18 DOORS**

**18.1** Drop doors, when over 150 mm in height, shall have a spring, counterbalance or friction control. An exception is made when structural steel forms are used exclusively for the front and door frames and breakable cast iron parts are not used in the hinging.

**18.2** Drop doors shall be such that when opened fully, they will lie and remain essentially in a horizontal position.

**18.3** Drop doors, when subjected to an initial concentrated load of 4.5 kg supplemented by a load of 22.5 kg both applied over a 64.5 cm<sup>2</sup> area for a period of 5 minutes without impact to one outer corner of the fully opened door with the other outer corner rigidly supported, shall not show :

- a) Breakage or permanent damage to any part thereof; and
- b) Deflection during application of the 22.5 kg load measured at the free corners in excess of 6.3 mm.

**18.4** Drop doors of ranges designed for battery installation, when subjected to an initial load of 22.5 kg supplemented by a load of 158 kg uniformly applied for a period of 5 minutes without impact, along a 300 mm strip the full width of the door, equidistant from the front and rear edge when fully open, shall not show:

- a) Breakage or permanent damage to any part thereof; and

- b) Deflection during application of the 158 kg load in excess of 6.3 mm at a point 150 mm from the hinge.

For all other hotel and restaurant ranges, the above provisions shall apply except that a load of 67.5 kg shall be used to supplement the initial load of 22.5 kg.

**18.5** Drop doors of ranges designed for battery installation, when protected by a 31.5 mm planking placed over the entire door arcs including frame, and subjected to a load of 22.5 kg applied by impact at the centre of the fully open door from a height of 300 mm shall not show breakage or permanent damage to any part thereof.

**18.5.1** For all other hotel and restaurant ranges the above shall apply except that a load of 11.2 kg shall be used.

## **19 BURNER BOXES AND BURNER BOX LINING**

**19.1** Burner boxes shall be enclosed for their entire height, on both sides and back. Suitable provisions may be made for a certain venting.

**19.2** Sheet-steel burner boxes constructed of material of a thickness less than 1.0 mm shall have a rust-resisting finish.

## **20 DRIP TRAYS**

**20.1** Every open top range shall be equipped with a drip tray or other adequate means to each water or other substances falling or dripping through openings in the top plates and grates.

**20.2** Drip trays or other means provided to serve the same function shall be constructed of a corrosion-resistant material or have a corrosion-resisting finish. Organic enamel finishes shall be considered as complying with this provision.

**20.3** Drip trays, when provided, shall present no sharp edges or corners. They shall be easily removable without tools when hot and easily accessible for cleaning.

## **21 OVEN AND BROILER LININGS**

**21.1** Ovens and broilers shall be furnished with linings at the sides and back which provide either (a) air space insulation or (b) enclosed solid insulation.

**21.2** Linings of ovens and broilers shall be constructed of a corrosion-resistant material or have a corrosion-resisting finish.

**21.3** When the linings are used solely for air space insulation, there shall not be less than 12.5 mm of non-circulating air space.

**21.4** When the backspace is used for flue purposes, there shall not be less than 19 mm space.

**21.5** Ovens shall be furnished with a top lining. When the top space is used for flue purposes, it shall provide not less than a 19 mm space.

**21.6** Linings, except for salamander broilers, shall be removable unless constructed of corrosion-resistant metal or possessing a corrosion-resistant coating, or constructed of sheet metal at least as thick as 1.60 mm is of the removable type, it shall be held in place without bolts. If the lining is of the removable type, it shall be held in place without bolts.

**21.6.1** No interference to the easy removal of unbolted linings shall be offered by the presence of accessories, such as oven heat regulators and oven pilots. The simple unscrewing of one or two unions, or bolts, shall not be construed as offering interference, although it is urged that the construction be such that the linings may be removed without the need of disconnecting the accessories.

**21.6.2** Similarly, accessories should be easily detachable without the need of removing bolted linings.

**21.7** Suitable provisions shall be made to prevent the linings from buckling.

**21.8** Sheet-steel linings, immediately over broiler burners, shall be of at least 1.0 mm. In appliances where the bottom of the top burner box constitutes the upper sheet of the oven or broiler flue space above the top lining, suitable insulation or protection shall be provided to prevent excessive heating of the bottom of the top burner box. Such insulation shall consist preferably of a head air space or thick insulating material with a sheet metal lining at the top of the flue space of not less than 0.80 mm sheet steel or its equivalent.

## **22 OVEN BOTTOMS**

**22.1** Oven bottoms shall be easily removable.

**22.2** When made of sheet steel, the bottom shall be double; and solid insulation, if used, shall not be exposed and shall be placed so that it will not shift.

**22.3** The bottom sheet of the oven bottom shall not be less than 1.0 mm.

## **23 EXTREME BOTTOMS AND BROILER BOTTOMS**

**23.1** Extreme bottoms and broiler bottoms may be fastened in place provided such construction in no way obstructs the easy removal of the oven linings.

## **24 OVEN RACKS AND BROILER PANS**

**24.1** Racks shall be of sufficient strength to sustain, without becoming dislodged, the following loads when distributed over the central two-thirds of the area of the racks.

Up to 508 mm widths	45.3 kg
---------------------	---------

Up to 610 mm widths	54.4 kg
Up to 711 mm widths	63.4 kg

**24.2** Oven racks and broiler pans shall be perfectly flat and shall not bind against the rack supports either before or after the oven is heated.

## **25 RACK SUPPORTS**

**25.1** Suitable provisions shall be made for firmly keeping the rack supports in place and to prevent the oven racks from binding.

## **26 OPEN TOP GRATES**

**26.1** The construction of the cooking top shall be such that at least 4 mm vertical clearance will be provided between the top surface of the grate prongs and the grate frame, cooking top frame or burner box sides. Construction providing equivalent relief to that specified above shall be considered satisfactory.

**26.2** Edges shall be gradually beveled to where they meet the top frame so that a vessel will slide on or off without a jar.

**26.3** When two or more top grates are used, they shall be designed so that they cannot be placed in any other than the proper position.

**26.4** Top grates shall drop into place positively and shall not be bolted or otherwise fastened.

**26.5** Provisions shall be made either to prevent the inversion of grates or to construct them, if inversion is possible so that the combustion will be unimpaired when operating the burners with the grates inverted.

**26.6** Grates on open-top ranges shall support, for 15 minutes, a load of 136 kg applied evenly and without impact over an area 208 mm in diameter at the centre of the grate without breakage, damage or permanent distortion.

## **27 SOLID TOP PLATES**

**27.1** The top plates of solid top ranges shall support, without breakage or apparent damage for a period of 15 minutes, a load of 362 kg applied evenly without impact over an area 406 mm in diameter at the centre of the top.

## **28 INSULATION**

**28.1** When insulation is employed, it shall be uniformly packed to provide even protection and to prevent shifting. Unless the insulation is of a type which is not adversely affected by moisture or elevated temperatures, it shall be protected from direct exposure to flue gases.



**28.2** Granular insulation shall not be used unless adequately protected against settling during shipment or normal use.

## **SECTION 2 PERFORMANCE**

### **29 GENERAL CONDITIONS OF TEST**

**29.1** General conditions of test specified in **19** of IS 5116 shall apply.

### **30 GAS CONSUMPTION**

**30.1** Each burner assembly under separate 'ON/OFF' control shall be within 10 percent of the manufacturer's declared gas consumption in g/h or kg/h when tested according to **30.2**.

**30.2** The flow through the injector Jet at normal pressure rating of the burner shall be measured with a gas meter using compressed air (free from oil/impurities) and converted the same at STP (27 °C and 760 mm Hg). Thereafter using 0.75 as a multiplying factor, the value of airflow at STP so obtain to be converted to the flow of LPG at STP.

NOTE — For the above test, one litre of LPG = 2.46 g.

The temperature of the room during the test shall be between 25°C and 30°C.

### **31 IGNITION AND FLAME STABILITY**

**31.1** The requirements given in **21.1** to **21.5** of IS 5116 shall apply.

#### **31.2 For Flashback**

A vessel large enough to cover the pan supports filled with water shall be placed on the burner under test. The burner flame shall be ignited while the inlet pressure is maintained at 80 percent of the rated pressure. Water may be added, if required to maintain the level. Gas rate recommended by the manufacturer shall be maintained for half an hour after which the gas input shall be reduced to 75 percent of the full gas rate and then brought back to the full gas rate. The operation shall be repeated five times. No flashback shall occur during the test.

#### **31.3 For Soot Formation**

A vessel large enough to cover the pan supports shall be filled with water up to a height of 50 mm and placed on the burner under test. The burner shall be ignited with the gas flow maintained at the full gas rate. Water may be added if required to maintain the level. After one hour, no soot (unburnt carbon) shall have been deposited on the bottom of the vessel. This shall apply for inlet pressures of 80 and 120 percent of the rated inlet pressure.

### **32 THERMOSTAT FLAME STABILITY AT BYPASS MAINTENANCE RATE**

**32.1** The requirements given in **21.6** of IS 5116 shall apply.

### **33 RESISTANCE TO DRAUGHT & COMBUSTION**

#### **33.1 Resistance to Draught**

There shall be no extinction of the flame of the burner at rated gas consumption when the burner is placed in a normal (not localized) current of air with a velocity of 2 m/s, as measured with a rotating vane anemometer. The location of the burner relative to neighboring walls and the direction of the draught shall be varied to correspond to the likely conditions of burner installation. This shall apply for all inlet pressures of 80, 100 and 120 percent of the rated inlet pressure.

#### **33.2 Combustion**

When tested according to the method laid down in Annex B, on no account the carbon monoxide/carbon dioxide ratio of exhaust gases, of the burner operating at any consumption at which the flame is stable at gas inlet pressure up to 147.1 kN/m<sup>2</sup> (1 500 gf/cm<sup>2</sup>) shall exceed 0.02. The carbon monoxide and carbon dioxide contents of the products of combustion shall be determined by the methods capable of accuracy of 0.001 percent and 0.5 percent, respectively of the volume of the sample.

### **34 SURFACE TEMPERATURE**

**34.1** Requirements given in **23** of IS 5116 shall apply.

### **35 THERMAL EFFICIENCY**

**35.1** The thermal efficiency of the top burners of open-top commercial cooking ranges shall not be less than 38 percent up to gas consumption 3 kg/h and 35 percent more than 3 kg/h, when tested by the method given in Annex C.

### **36 OVEN HEATING CAPACITY**

**36.1** Ovens and their control shall be designed so that the oven temperature can be increased from room temperature to 26°C at an average rate of at least 17°C/minute when tested by the method given in Annex D.

### **37 OVEN MAINTAINING RATE**

Maintenance of an equilibrium oven temperature of 221°C above room temperature with insulated ovens shall not require more than 309 186 kcal/hour/m<sup>2</sup> of oven space when tested by the method given in Annex E.

### **38 OVEN HEAT DISTRIBUTION**

The heat distribution in the oven shall be uniform so that the plain layer cakes baked at  $191 \pm 5^{\circ}\text{C}$ , for 25 to 30 minutes unless otherwise specified by the manufacturer, will be evenly browned when tested by the method given in Annex F. This provision shall be deemed met if the top and bottom surfaces of all the baked cakes have not more than 58 percent nor less than 25 percent reflectance when measured in segments of not less than  $3.35 \text{ cm}^2$  in area for light reflectance characteristics by means of a photoelectric reflectometer or similar device. Reflectances are referred to magnesium carbonate as 100 percent.

### **39 BROILER TEMPERATURES**

The average broiler temperature shall reach  $315^{\circ}\text{C}$  above room temperature within 30 minutes when tested by the method given in Annex G.

### **40 BROILER HEAT DISTRIBUTION**

The heat distribution in broiler shall be uniform. This provision shall be deemed met when the temperature difference in the broiling area does not exceed  $65.5^{\circ}\text{C}$  when tested by the method given in Annex H. Open-top broilers are exempt from this provision.

### **41 OVEN AND BROILER DOOR RELIEF**

**41.1** The oven and broiler door shall open when a pulling force of 22.6 kg is applied at each door handle in a direction which is normal to the plane of the door when tested by the method given in **41.1.1**.

**41.1.1** The oven thermostat shall be set at its  $26^{\circ}\text{C}$  setting and the oven shall be operated at normal test pressure for a period of 30 minutes before applying the test outlined below:

In the case of separate broilers, the gas shall be ignited at the broiler burner and the broiler operated at normal test pressure for a period of 30 minutes. A weight of 22.6 kg shall be attached to a point adjacent to the oven or broiler door handle by means of a wire which extends over a pulley, the direction of pull being perpendicular to the plane of the door without a jar. The door shall open easily when the load is applied without jar. As an alternative, test load may be applied by means of a spring scale, held horizontally and attached to the door. When the handle is of such a nature that the application of the load on it will not tend to disengage the door latching mechanism, the wire or spring scale may be attached to the handle. This test shall also be applied with the oven and broiler at room temperature.

## **SECTION 3 GENERAL**

### **42 INSTRUCTIONS**

**42.1** Clearly defined and complete instructions for lighting and shutting down the appliance shall be provided on a permanent and rust-resistant plate: which shall be securely fastened on or adjacent to the controlling device or in an equally conspicuous position where the instructions can be easily

read. Lighting instructions shall require a 5 minutes complete shutoff period before the appliance is re-lighted.

**42.2** Commercial ranges shall be accompanied by printed instructions and diagrams adequate for their proper field assembly, installation and safe operation, including all control and accessories.

**42.3** Except when electrical equipment is limited to one incandescent lamp fixture, electrical diagrams of all circuits within the appliance shall be permanently attached to the appliance. Some means of colour, letter or number coding shall be used in the diagram to facilitate circuit identification.

**42.4** Each oven shall be supplied with an instruction card or cards giving the following information:

- a) Brief instructions for installation and regulation and maintenance of the appliance. This includes end terminals, if any;
- b) Gas consumption in kcal/h;
- c) Working pressure of the gas; and
- d) Any special instructions for the correct operation of the appliance.

## **43 MARKING**

**43.1** Commercial ranges shall bear a permanent rust-proof rating plate located where it can be easily read when the appliance is in the normally installed position on which shall appear the following:

- a) The manufacturer's or distributor's name or initials or registered trade-mark,
- b) For use with LPG,
- c) Manufacturer's normal hourly input rating of each main burner,
- d) Any such instructions for the safe operation, and
- e) Country of origin.

**43.1.1** The information given in **43.1** shall be distinct, permanent and easily accessible when the cooking range is installed as it would be in service.

### **43.2 BIS Certification Marking.**

The commercial ranges may also be marked with the BIS Standard Mark.

**43.2.1** The use of the Standard Mark is governed by the provisions of *Bureau of Indian Standards Act, 2016* and the Rules and Regulations made thereunder. The details of conditions, under which a license for the use of the Standard Mark may be granted to manufacturers or producers, may be obtained from the Bureau of Indian Standards.

## **44 PACKING**

**44.1** The commercial ranges shall be packed as agreed to between the purchaser and the supplier, taking care of safety requirements during handling and transit to protect against damage.

**ANNEX A**  
(Clause 17.4)

**METHOD OF TEST FOR DRAFT HOOD**

**A-1 PROCEDURE**

**A-1.1** The inlet of a vertical or horizontal-to-vertical type draft hood shall be attached in its normal operating position to a fixed flue pipe. In the case of horizontal-to-vertical type hoods, this attachment shall be secured by means of 5 mm bolts, one in the upper and one in the lower part of the joint. A vertical compression load equal to 0.89 kg/cm of nominal outlet diameter shall be applied without impact to the outlet of the hood.

**A-1.2** The inlet of a horizontal or vertical-to-horizontal type draft hood shall be attached in its normal operating position to a fixed flue pipe by 5 mm bolts. For horizontal-type draft hoods, one bolt shall be placed in the upper and one in the lower part of the joint. For vertical-to-horizontal type draft hoods, the bolts shall be placed through the inlet joint parallel to the other directly opposite to the outlet connection. A 3 m length of 0.50 mm sheet steel flue pipe of suitable diameter shall then be attached in a horizontal position to the outlet connection of the draft hood, the other end of the length of pipe being supported at a point not more than 25 mm from its extremity.

**A-1.3** The gas rate to all burners which vent through the draft hood shall be adjusted, the gas ignited, and the increased test pressure applied. If top burners are vented through the draft hood, they shall be covered by suitable water-filled utensils. When a locking device prevents the operation of the separate oven and broiler burners at one time, two tests shall be conducted, one with each burner operated.

**A-1.4** After the temperature at the centre of the oven has reached 28°C as indicated by thermocouples the gas supply shall be regulated to maintain this temperature and the test shall be started. The appliance shall be operated for one hour under these conditions. If no distortion of any part of the draft hood is noted at the end of the test period, it shall be considered as complying with this provision.

**ANNEX B**  
(Clause 33.2)

**TEST METHOD FOR DETERMINATION OF CARBON  
MONOXIDE/CARBON DIOXIDE RATIO**

**B-1 PROCEDURE**

**B-1.1** The appliance shall be set-up in accordance with clause **33.2**. Before starting the test, a pan of suitable diameter and of suitable height and containing water sufficient for the test shall be placed over the burner. In addition, a collecting hood (*see* Fig. 1 & 2) suitable for the burners under examination shall be obtained.

**B-1.1.1** The hood shall be so designed that, while not interfering in any way with the normal combustion of the burner, it collects a fairly high proportion of the products of combustion. Also, it shall be such that the sample collected represents the whole of the combustion gases and not those from any particular point.

When using this hood, the damper provided shall be set or additional flue pipe added, so that spillage of the flue gases around the skirt is just prevented. With the sample hood in position over the burner under investigation, gas at inlet pressure of  $34.323 \text{ kN/m}^2$  ( $0.35 \text{ kgf/cm}^2$ ) shall be admitted and the burner operated for a 5 to 10 minutes till the steam is out before sampling commenced. The reason for this being that during the first 5 to 10 minutes the burner is warming up and the proportion of carbon monoxide may be high. However, this is not dangerous provided the burner works satisfactorily after heating up.

**B-1.2** Any of the recognized methods having the prescribed accuracy may be used for gas analysis. For carbon monoxide, it is recommended that co-indicator of prescribed accuracy or iodine pentoxide method or catalytic method, for example, Dragger method, the Katz method or infrared analysis methods may be used. Carbon dioxide may be tested with an Orsat apparatus, the Haldane apparatus or by infrared analysis.

**B-1.3** Each burner shall be examined with gas at  $34.323 \text{ kN/m}^2$  ( $0.35 \text{ kgf/cm}^2$ ) inlet pressure. It shall also be noted that each burner is tested separately or with all the possible combination of the other burners operating.

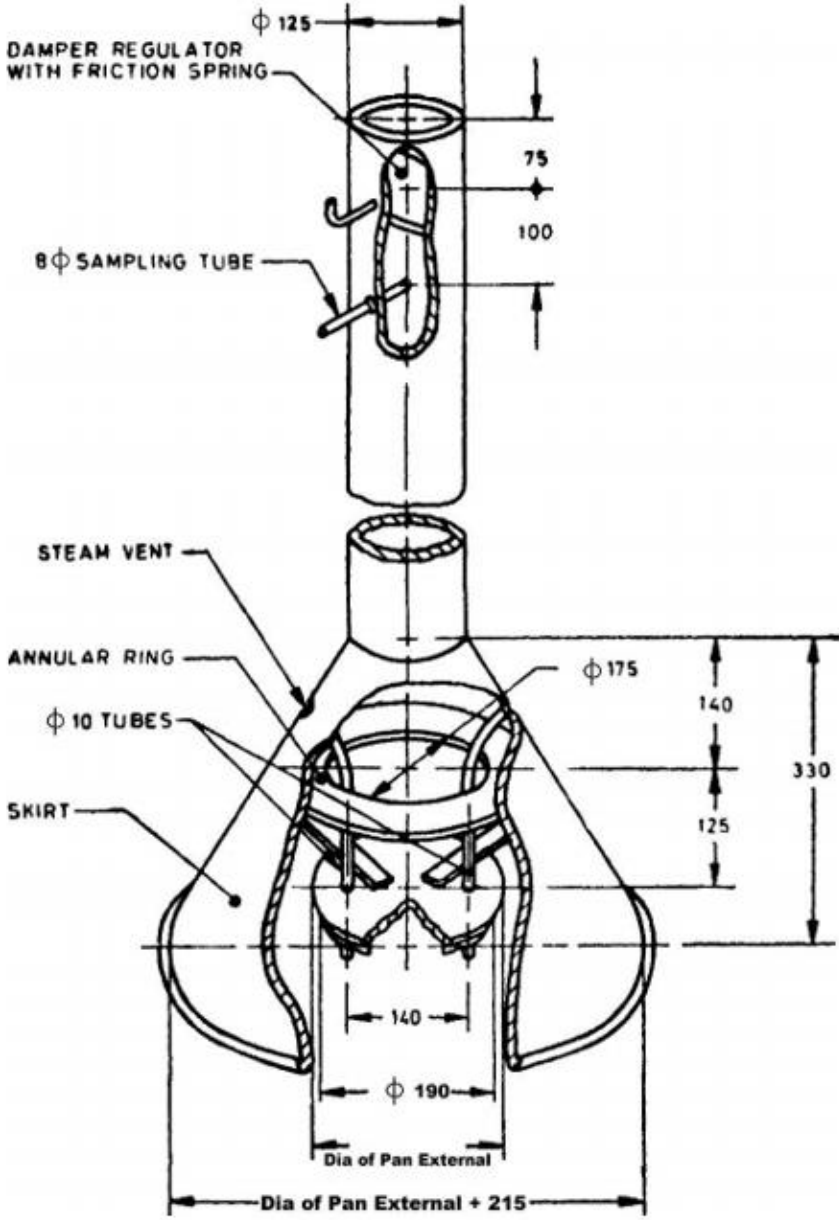

(All dimensions in millimetres)

FIG. 1 HOOD FOR BURNER (ROUND HEAD)





**ANNEX C**  
(Clause 35.1)

**METHOD FOR MEASUREMENT OF TOP SECTION THERMAL EFFICIENCY**

**C- 1 PROCEDURE**

**C-1.1** The test shall be carried out by weighing the gas used. The gas shall be taken from standard supply LPG cylinder for domestic or commercial use.

**C-1.2** The number of cylinders to be used for the test shall be equal the burner consumption rate in kg/h, to next higher integer. Where only one cylinder is required, an adaptor shall be fitted to the cylinder valve. An 'ON/OFF' valve shall be fitted downstream of the adaptor. This valve shall be positioned as near the adaptor as possible. A pressure regulator shall be fitted downstream of the valve. Where more than one cylinder is required a cylinder manifold shall be provided.

**C-1.3** The outlet pressure of the pressure regulator shall be equal to the manufacturer's recommended burner inlet pressure. Test shall be carried out for the gas burning rate at a gas pressure of 34.323 kN/m<sup>2</sup> (0.35 kgf/cm<sup>2</sup>). The burner to be tested shall be assembled in the test appliance according to the manufacturer's recommendations. Dimensions of this test appliance for 'M' and 'T' type burner shall conform to fig.3 the rounded off.

Manufacturer shall declare the dimensions of the pan supports and the distance between the top of the burner to top of the pan support (bottom of the vessel). Test appliance and other required details for 'V' type burners shall be declared by the manufacturer. A pressure gauge of suitable range shall be fitted between the regulator and the burner.

**C-1.4** The gas shall be passed through the burner for a few minutes to purge the system and to establish the gas pressure required. Only one burner shall be tested at a time and during the test, all gas delivered from the cylinder(s) shall flow through the jet(s) of the burner being tested. The pan shall be selected and filled with water in accordance with the requirements given in Table 1 and Table 2, and placed centrally over the burner being tested.

The water temperature (t) shall be noted and recorded as long as it remains constant. The cylinder shall be disconnected after closing the 'ON/OFF' valve and the initial weight of the cylinder (W) recorded. Then the cylinder shall be reconnected and the 'ON/OFF' valve reopened. The gas control tap shall then be switched on and the gas shall be ignited. Stirring shall be commenced when the water temperature reaches 80 °C and continued until the end of the test. When the water temperature reaches 90±1 °C, burner tap and 'ON/OFF' valve shall be switched off. The stirring shall be continued and temperature shall be recorded every 30s. Final temperature (r) shall be taken as the highest temperature recorded. The cylinder shall be disconnected and final weight of the cylinder (w<sub>2</sub>) shall be recorded. The thermal efficiency of the burner shall be calculated from the following formula:

$$e = \frac{100 [M + M' \times 0.214] \times [t_2 - t_1]}{[W_1 - W_2] \times 10\,900}$$

Where

- $e$  = thermal efficiency of the burner in percent,
- $M$  = quantity of water in the vessel in kg
- $M'$  = weight of the vessel in kg, complete with stirrer and lid,
- $t_1$  = initial temperature of the water in °C,
- $t_2$  = final temperature of the water in °C,
- $W_1$  = weight of cylinder in kg before the test, and
- $W_2$  = weight of cylinder in kg after the test.

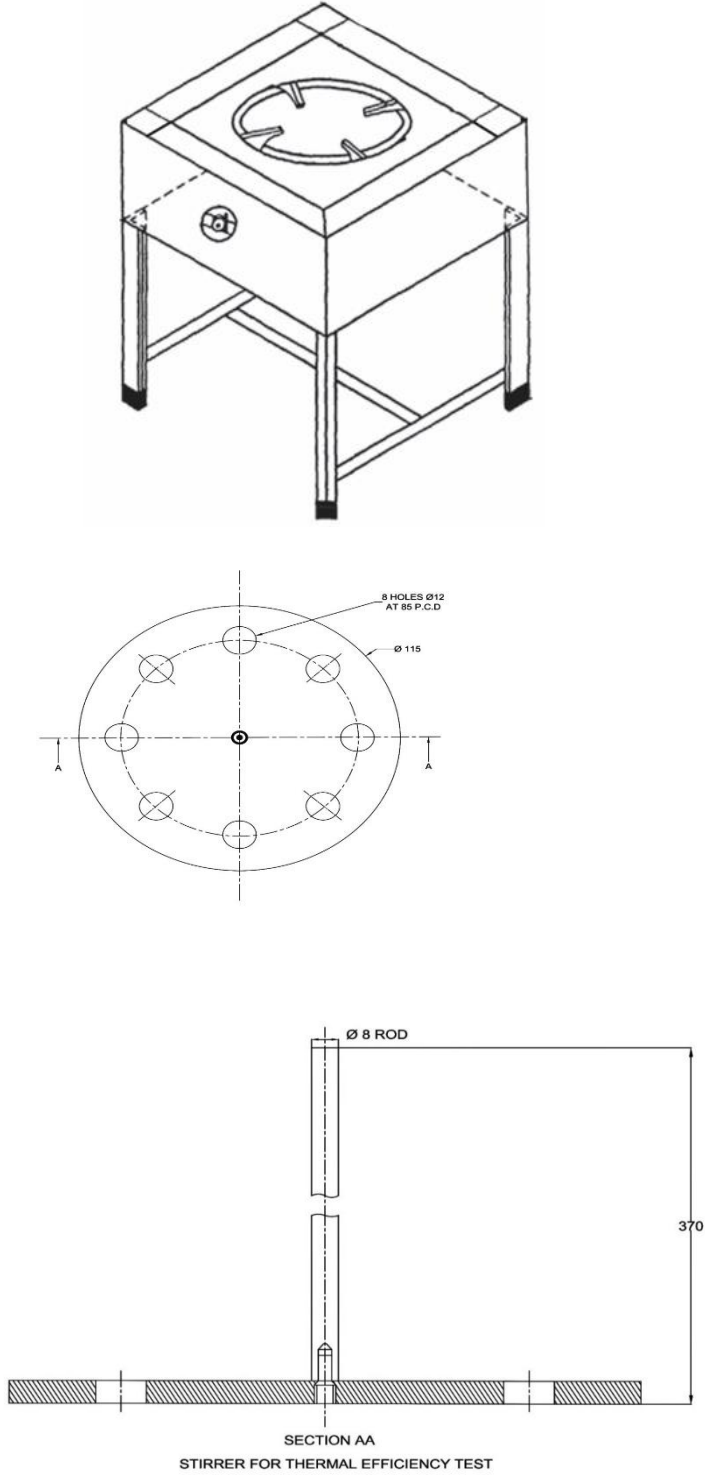

(All dimensions in millimetres)

FIG. 3 A TYPICAL TYPE OF COOKER RANGE. (MANUFACTURER CAN USE ANY SIZE AND SHAPE OF PAN SUPPORT)

**C-2** In performing the thermal efficiency test, the following shall be noted:

- a) The set-up shall be carefully checked for Teaks, before and after the test. If a leak is found after the tests, the results should be cancelled and the test repeated;
- b) The initial temperature of the room shall be between 20 to 30 °C. The water temperature shall be within  $\pm 2$  °C of the actual room temperature;
- c) The room shall be free from draught;
- d) At the start of the test, the burner shall be at room temperature;
- e) The temperature of the water shall be measured by means of a mercury-in-glass thermometer with an accuracy of 0.5 °C and the bulb of which is immersed to half the depth of the water in the vessel. Alternatively, any other temperature-measuring devices shall be permitted;
- f) For insertion of the thermometer, a hole of 8 mm dia shall be drilled into the pan lid at the centre and assembled with a suitable cork. The thermometer shall be inserted through a suitable hole drilled into the cork;
- g) Stirring shall be effected by means of two disc-type stirrers (see Fig. 3) fitted symmetrically and attached to an upright which passes through a 8 mm hole drilled in the lid. Stirring may be affected by mechanical means. The lid shall be clamped with a pan to avoid spillage;
- h) The least count of weighing balances used shall be 10 g or better;
- j) Specific heat of aluminium is 0.214; and
- k) If the net calorific value of gas used is not determined experimentally, the value may be taken as 10 900 kcal/kg for calculation.

**Table 1 Vessels for Thermal Efficiency Test**  
(Clause B-1.4)

Sl. No.	Gas Burning Rate Upto kg/h	External Diameter in (mm) $\pm 5\%$	External Height in (mm) $\pm 5\%$	Mass of reel and lid in kg $\pm 10\%$	Mass of water in kg
(1)	(2)	(3)	(4)	(5)	(6)
i)	1.000	380	205	2.560	16.50
ii)	1.500	420	220	3.070	24.00
iii)	2.250	495	265	4.520	37.00
iv)	3.500	595	320	8.450	58.00

NOTES

- 1) Distilled water (*see* IS 1070) shall be used for the test
- 2) The pan shall be cylindrical with a flat bottom.
- 3) The pan bottom shall have a bright finish from inside.
- 4) For burners having gas ratings above 3.5 kg/h, special pans shall be constructed to conform as far as possible with the principles used in formulating this table as given below:
- 5) For different LPG commercial burners of different burning rate, the criteria for selection of different vessel size and water quantity is based on identical testing time (approximately 17 min). The ratio of total water equivalent to gas burning rate shall be  $17 \pm 0.5$ .

**Table 2 Aluminum Pans for Thermal Efficiency Test (for Dosa /making cooking ranges)**  
(Clause B-1.4)

Length of Burner in (mm) 	300	600	900	1 200
Pan External Dimensions (mm)				
Length $L$ , mm $\pm 5\%$	450	750	1 050	1 350
Width $W$ , mm $\pm 5\%$	300	300	300	300
Height $H$ , mm $\pm 5\%$	225	135	100	75
The total mass of pan with Lid and Stirrer in kg $\pm 10\%$	3.530	4.210	5.110	5.960
Mass of water in kg	24.00	24.00	24.00	24.00

NOTES

- 1) Distilled water (*see* IS 1070) shall be used for test.
- 2) The pan bottom shall have a bright finish from inside.
- 3) The criteria for selection of different vessel size and water quantity is based on identical testing time (approximately 17 min). The ratio of total water equivalent to gas burning rate shall be  $17 \pm 0.5$ .
- 4) Calculation of the mass of pan, lid and stirrer is based on 2 mm thick aluminum sheet. Stainless steel sheet may be used for the fabrication of the pan, lid and stirred. Corresponding changes in mass and water equivalent shall be used for calculating the efficiency.

---

\*1 kcal/h = 1.163 J/s.

(Clause 36.1)

## **METHOD FOR MEASUREMENT OF OVEN HEATING CAPACITY**

### **D-1 PROCEDURE**

**D-1.1** The temperature of the oven shall be measured by an indicating or recording potentiometer and five parallel-connected thermocouples, one located at the centre and the other four equally spaced between the centre and the corners of the oven on the diagonals of a horizontal plane through the centre of the oven.

**D-1.2** The gas rate shall be adjusted at normal test pressure to within  $\pm 2$  percent of the manufacturer's hourly kcal input rating. On ranges equipped with thermostats, the dial shall be set at the maximum position.

**D-1.3** The gas shall be ignited with the oven at room temperature and the time required to reach 260 °C noted. The average heating rate shall be computed by means of the following formula and shall not be less than 9.5 degrees/minute.

$$\text{Average heating rate} = \frac{260 \text{ }^{\circ}\text{C} - \text{Room temperature}}{\text{Observed heating time}}$$

**ANNEX E**  
(Clause 37.1)

**METHOD FOR MEASUREMENT OF OVEN MAINTAINING RATE**

**E-1 PROCEDURE**

**E-1.1** The oven temperature shall be measured by an indicating or recording potentiometer and five parallel-connected thermocouples, one located at the centre and the other four equally spaced between the centre and corners of the oven on the diagonals of a horizontal plane through the centre of the oven. This test shall be conducted at normal test pressure.

**E-1.2** The oven temperature shall be brought to and maintained at 260 °C. The gas consumption shall then be measured over a period of 1 hour. The oven temperature shall be deemed constant if the potentiometer readings do not vary by more than 5.5 °C during this 1-hour period. The oven maintaining rate shall be determined by the following formula:

$$\text{Oven maintaining rate} = \frac{HFQK}{V}$$

Where

- H* = gross heating value of gas in kcal/l,
- F* = correction factor to reduce observed gas volume to standard conditions,
- Q* = volume of gas burned as recorded in l,
- K* = 1.0 for direct-fired ovens and 0.875 for indirect ovens, and
- V* = volume of oven in m<sup>3</sup>.

**ANNEX F**  
(Clause 38.1)

**METHOD FOR MEASUREMENT OF OVEN HEAT DISTRIBUTION**

**F-1 PROCEDURE**

**F-1.1** This test shall be conducted at normal test pressure. Five parallel connected thermocouples shall be inserted in the baking oven and shall be equally spaced on the diagonals of a horizontal plane through the centre of the oven. The oven shall be brought to a temperature of 190°C and maintained at approximately that temperature.

**F-1.2** The number of cakes baked shall be as specified by the manufacturer but not less than one per 0.093m<sup>2</sup> of rack area (fractional areas are not to be considered). Knockout bottom type 0.64 mm aluminium cake pans, 200 mm in diameter × 37 mm deep shall be used. Each cake pan shall contain 3.36 kg of cake batter.

**F-1.3** The cakes shall be baked on a rack in the position nearest the centre of the oven. The pans shall be symmetrically located and spaced as evenly as possible with respect to each other and the sides, front and rear of the oven.

**F-1.4** The time required to open the oven door, insert the cake pans, and close the oven door shall not exceed 30 seconds.

**F-1.5** The cakes shall be baked for 25 to 30 minutes unless otherwise specified by the manufacturer, removed from oven, cooled to room temperature and measured for reflectance.

The recipe for sufficient cake batter for five cakes is as follows:

230 g (1¼ cups)	Hydrogenated vegetable oil shortening
13 ml (2½ teaspoons)	Vanilla
500 g (2½ cups)	Granulated sugar
240 g (5 eggs)	Eggs
40 ml (1¾ cups)	Milk
530 g (5¼ cups)	Sifted soft wheat cake flour
20 g (5¼ teaspoons)	Retarded action baking powder
6 g (1¼ teaspoons)	Salt

**F-1.6** All ingredients shall be at room temperature. Ingredients shall be weighed and measured before mixing. Baking powder and salt shall be added to flour, sifted together 3 times, and divided into 3 portions. Milk shall be divided into 2 parts. Bottoms of pans shall be greased.

**F-1.7** A 3-speed mixer equipped with an off-centre flat beater shall be used in all mixing operations. High speed shall provide 600 rotations per minute; medium, 325 per minute; and low



speed, 250 per minute. Mixing of all ingredients shall be done in a mixing bowl 200 mm in diameter and 165 mm deep.

**F-1.8** Put shortening and vanilla in mixer bowl. With beater operating at high speed, add sugar gradually over a period of 1 minute. Stop mixer and scrape sides of bowl. Beat for 1 minute. Stop mixer and scrape sides of bowl. Beat 1 minute longer at high speed. Turn to medium speed, add unbeaten eggs gradually over a period of 1 minute. Stop mixer, and scrape bowl and beat 1 minute longer at medium speed. Stop the mixer and scrape the bowl. Turn mixer to low speed, adding 1/3 of the dry ingredients over a period of 1 minute, and 4 the milk over a period of 30 s. Stop the mixer at the end of the second addition of flour, scraping down the sides quickly. At the end of the third addition of flour, stop the mixer, scrape down the sides of the bowl, turn to medium speed and beat 10 seconds longer. Pour the batter quickly into the pans, smoothing evenly and rap each pan sharply 3 times on the table to remove air bubbles.

When removed from the oven, allow cakes to stand in pans for 3 minutes, then turn out on cake coolers.

#### **F-1.8.1** *Alternate Procedure and Recipe*

Add sugar and margarine and beat until light and fluffy. Add 2 to 3 eggs at a time and continue beating. Flour and baking powder to be sifted to and added to the mix. Use mixer at a very slow speed or incorporate it with a wooden spoon. Put into suitable size moulds/molds and bake at 190°C.

<i>Recipe</i>	<i>Amount</i>
Maida flour	500 g
Sugar	500 g
Eggs	500 g
Margarine (hydrogenated approximately 82% fat)	500 g
Vanilla essence	20 ml
Lemon essence	10 ml
Baking powder	15 g

**ANNEX G**  
(*Clause 39*)

**METHOD FOR MEASUREMENT OF BROILER TEMPERATURE**

**G-1 PROCEDURE**

**G 1.1 Broilers other than Open Top Broilers**

This test shall be conducted at normal test pressure. Broiler temperatures shall be determined by means of an indicating potentiometer and nine parallel-connected iron-constantan thermocouples, the junctions of which are copper plates 25 mm in diameter and 0.79 mm thick to which the thermocouples wires are silver-soldered 12 mm apart. These discs shall each be located at the centre of the top surface of an asbestos board 37 mm in diameter and 9.5 mm thick. The size of the iron-constantan wires shall be 0.50 mm. The surfaces of the copper discs and the asbestos board shall be finished in dull black.

**G-1.2** The asbestos boards bearing the thermocouples shall be located on rectangular racks in the following manner: one in each corner with its outer edges coinciding with the edges of the rack, one in the centre of the rack and four on the diagonals through the centre of the rack located respectively midway between the centre board and each of the four corner boards, When the corner of a rack is cut away to permit access to the broiler pan the board ordinarily placed on this corner shall occupy the same position as it would if the rack were not cut away.

**G-1.3** In the case of round broiler racks, the asbestos boards shall be placed as described in **F-1.2**, on a square which is circumscribed by the outer circumference of the rack, two sides of which are parallel to the front of the unit.

**G-1.4** The asbestos boards shall be positioned and supported so that the upper surfaces of the copper discs will be a vertical distance of 50 mm below the burner ports, except when the broiler compartment requires a lesser distance, in which case the maximum distance shall be utilized.

**G-1.4.1** Thermostats, if provided, shall be set at maximum temperature position. With the broiler at room temperature the gas shall be turned on and ignited and both the oven and broiler doors, if any, closed. The average broiler temperature shall be determined and shall have reached 330°C within 30 minutes.

**G-2 OPEN-TOP BROILERS**

**G-2.1** This test shall be conducted at normal test pressure. Broiler temperatures shall be determined by means of an indicating potentiometer and nine parallel-connected iron-constantan thermocouples, the junctions of which are copper plates 25 mm in diameter and 0.80 mm thick, to which the thermocouple wires are silver-soldered 12 mm apart. These discs shall be installed flush with the undersurface of a 9.5 mm thick asbestos board large enough to cover 75 percent of the grid area. This board shall be shaped so that when centrally positioned on the grid the uncovered area is a space of equal width around the perimeter of the board. The surface of the board shall be

divided into 9 sections of equal area and one thermocouple shall be installed at the centre of each section. The size of the iron constantan wires of the thermocouple junction shall be 0.50 mm. The surfaces of the copper discs and the asbestos board shall be finished in dull black.

**G-2.1.1** With the appliance at room temperature the gas to the broiler burner shall be turned on and ignited. The average broiler temperature shall be determined and shall have reached 330°C within 30 minutes.

**ANNEX H**  
(*Clause 40*)

**METHOD FOR MEASUREMENT OF BROILER HEAT DISTRIBUTION**

**H-1 PROCEDURE**

**H-1.1** This test shall be conducted at normal test pressure. The broiling area shall be centrally located with respect to the broiler pan or rack. It shall be marked off on the broiler pan or on the broiler rack when no pan is provided, by lines parallel to each edge and in from the edge 6.3 mm the distance to the centre.

**H-1.2** Five individually connected asbestos disc thermocouples shall be placed in the broiling area, located one in each corner with its outer edges coinciding with the boundary lines and one in the centre. The broiler pan then shall be placed in the broiler compartment in its highest position, but with its upper surface no closer to the burner ports than 5 mm. When a broiler door is provided, it shall be closed. The burner shall be placed in operation and temperatures measured with an indicating potentiometer.

When the average of the temperatures measured by the 5 thermocouples reaches 315.5°C, the individual temperature readings shall be recorded. The difference between the maximum and minimum temperature shall not exceed 83°C.