

**BUREAU OF INDIAN STANDARDS**

**DRAFT FOR COMMENTS ONLY**

*(Not to be reproduced without the permission of BIS or used as an Indian Standard)*

---

भारतीय मानक मसौदा

भेड़ और बकरियों का आवास - रीति संहिता

( आई एस 2733 का दूसरा पुनरीक्षण )

*Draft Indian Standard*

**HOUSING OF SHEEP AND GOATS – CODE OF PRACTICE**

*(Second Revision of IS 2733)*

**ICS 65.020.30**

---

Animal Husbandry and Equipment  
Sectional Committee, FAD 32

Last date of comment: **19 May 2024**

---

**FOREWORD**

*(Formal clause will be added later)*

Sheep and goats form an integral part of the country's rural economy for their multifaceted role in providing wool, meat, milk, skin, hair and manure. Sheep and goats have been raised for meat, milk and wool for thousands of years and were milked even prior to cows. As per the increasing demand of animal protein in the country it is necessary to augment meat production from sheep and goat besides other animal protein sources (milk, fish, egg, chicken, etc.). Apart from meat, natural fibres from sheep (wool) and goats (pashmina) are important products that cater to needs of country's woollen and carpet industries. This Indian Standard suggests suitable and economical structures for raising small flocks of these animals under different climatic zones as well as for different categories of farmers which serve as a guide to those farmers who would like to raise these animals as a part of their livelihood and job security besides model layout plan for different commercial unit flocks.

This standard was first published in 1964, and subsequently revised in 1985. In this second revision, various provisions of the standard have been reviewed thoroughly and made more comprehensive by updating terminology, including layouts of different sub structures with a view to keeping abreast with the changing rearing practices and the experience gained in due course of time by research findings of national research institutions (ICAR-CIRG, Mathura, ICAR-CSWRI, Avikanagar) as well as commercial sheep and goat farmers/entrepreneurs. Further, the standard has been brought out in the latest style and format of the Indian Standards, and references to Indian Standards wherever applicable have been updated.

For the purpose of deciding whether a particular requirement of this standard is complied with, the final value, observed or calculated, expressing the result of a test or analysis, shall be rounded off in accordance with IS 2 : 2022 'Rules for rounding off numerical values (*second revision*)'. The number of significant places retained in the rounded off value should be the same as that of the specified value in this standard.

## 1 SCOPE

This standard prescribes the general layout of the shelter and the methods of construction of the small, medium and large sized houses for sheep and goats in different agro-climatic regions of India.

## 2 REFERENCES

The following standards contain provisions which through reference in this text, constitute provision of this standard. At the time of publication, the editions indicated were valid. All standards are subject to revision and parties to agreements based on this standard are encouraged to investigate the possibility of applying the most recent editions of the standards indicated below:

<i>IS No.</i>	<i>Title</i>
IS 258 : 2000	Potash alum — Specification ( <i>second revision</i> )
IS 277 : 2018	Galvanized steel strips and sheets (Plain And Corrugated)—( <i>seventh revision</i> )
IS 712 : 1984	Specification for building limes ( <i>third revision</i> )
IS 737 : 2008	Wrought aluminium and aluminium alloy sheet and strip for general engineering purposes — Specification ( <i>fourth revision</i> )
IS 797 : 1982	Specification for common salt for chemical industries ( <i>third revision</i> )
IS 1077 : 1992	Common burnt clay building bricks — Specification ( <i>fifth revision</i> )
IS 1237 : 2012	Cement concrete flooring tiles — specification ( <i>second revision</i> )
IS 2212 : 1991	Brick works — Code of practice ( <i>first revision</i> )
IS 12894 : 2002	Pulverized fuel ash - Lime bricks – Specification
IS 13757 : 1993	Burnt Clay Fly Ash Building Bricks-specification
IS 16720 : 2018	Pulverized Fuel Ash-Cement Bricks- Specification

## 3 TERMINOLOGY

For the purpose of this code, the following definitions shall apply:

### 3.1 Sheep

**3.1.1 Ewe** — Adult female sheep of above 15 months age.

**3.1.2 Ram** Adult male sheep of above 15 months age.

**3.1.3 Lamb** – Young sheep up to 3 months of age.

**3.1.4 Weaner** – Young sheep from 4 to 6 months of age.

**3.1.5 Ram lamb** Young male sheep from 6 to 9 months of age.

**3.1.6 Ewe lamb-** Young male sheep from 6 to 9 months of age.

**3.1.7 Yearling** – Young sheep from 10 to 15 months of age of both sexes.

## **3.2 Goat**

**3.2.1 Doe** – Adult female goat of above 15 months age.

**3.2.2 Buck** – Adult male goat of above 15 months age.

**3.2.3 Kid** – Young goat up to 3 months of age.

**3.2.4 Weaner** – Young goat from 4 to 9 months of age.

**3.2.5 Buck kid** - Young male goat from 6 to 9 months of age

**3.2.6 Doe kid** - Young male goat from 6 to 9 months of age.

**3.1.7 Yearling** – Young goat from 10 to 15 months of age of both sexes.

## **4 LOCATION**

The housing for sheep and goats shall be located on a dry, elevated and well drained place, not exposed to strong winds, heat or cold. A place, where there is a longer period of shade in a day, should be preferred. Long axis of shed should be in East-West direction, in other words, longer walls should face the north-south direction.

NOTE – In case, the location for construction is within the municipal limits, the plan for construction shall follow the relevant by-laws prescribed by the municipal authorities of the place.

## **5 PLAN**

**5.1** Shelter with covered area under roof along with open paddocks for housing sheep and goats is considered as minimum facility in both welfare and production. Housing with different space and provision is recommended for different sheds like pregnant ewe/doe shed, lambing/kidding shed, lambs/kids shed, yearling sheep and goats shed, breeding rams/bucks shed, ewe/doe shed, sick animals shed, quarantine shed etc. The recommended minimum floor and ventilation space requirements for sheep and goats are given in Table 1 and Table 2. There should be separate space for shepherds, storage of feeds and fodder and other appliances. The number of sheds for each type to be provided in the shelter depends on the number of animals to be looked after/reared. The area of each shed depends upon the minimum floor space specified for each animal and the number of animals to be kept in each shed. The arrangement for pregnant animals, lactating females, young animals up to 3 months age should be adjacent to each other, the breeding males and dry females should be adjacent to each other in planning layout of sheep/goat shed.

**Table 1 Minimum floor space requirements for sheep and goats**  
(Clause 5.1)

Sl. No.	Age / Category of goats	Covered area (m <sup>2</sup> /animal)	Open paddock (m <sup>2</sup> / animal)
(1)	(2)	(3)	(4)
1	0 - 3 months	0.2-0.25	0.4 - 0.5
2	3 - 6 months	0.5 - 0.75	1.0 – 1.5
3	6 - 12 months	0.75 - 1.0	1.5 – 2.0
4	Yearling sheep and goats	1.00	2.00
5	Adult sheep and goats	1.5	3.0
6	Pregnant and lactating sheep and goats	1.5 - 2.0	3.0 - 4.0
7	Rams/Bucks	1.5 - 2.0	3.0 - 4.0

**Table 2 Minimum ventilation space requirements for sheep and goats**  
(Clause 5.1)

Sl. No.	Season	Ventilation space (% of floor area)
(1)	(2)	(3)
1	Hot dry	70%
2	Hot humid	100% (Longer sides be kept totally open)
3	Cool	2-10% or provide flexible ventilation. i.e. Maximum between 10 am to 4 pm, and closing the ventilation space between 4 pm to 10 am.
4	Comfortable	25%

The layout plan for sheep and goat shelter vary with sheep/goat keepers' resource availability, purpose of rearing, climatic conditions etc. However, the general plan is given in Fig. 1. and the recommended floor layout plan for common unit sizes of 10+1, 25+2, 50+3, 100+5, 500+25 along with followers are given in Fig.2, Fig.3, Fig.4, Fig.5, Fig. 6, respectively. The floor plan for 15 goats with followers for hill region is also given in Fig. 7.

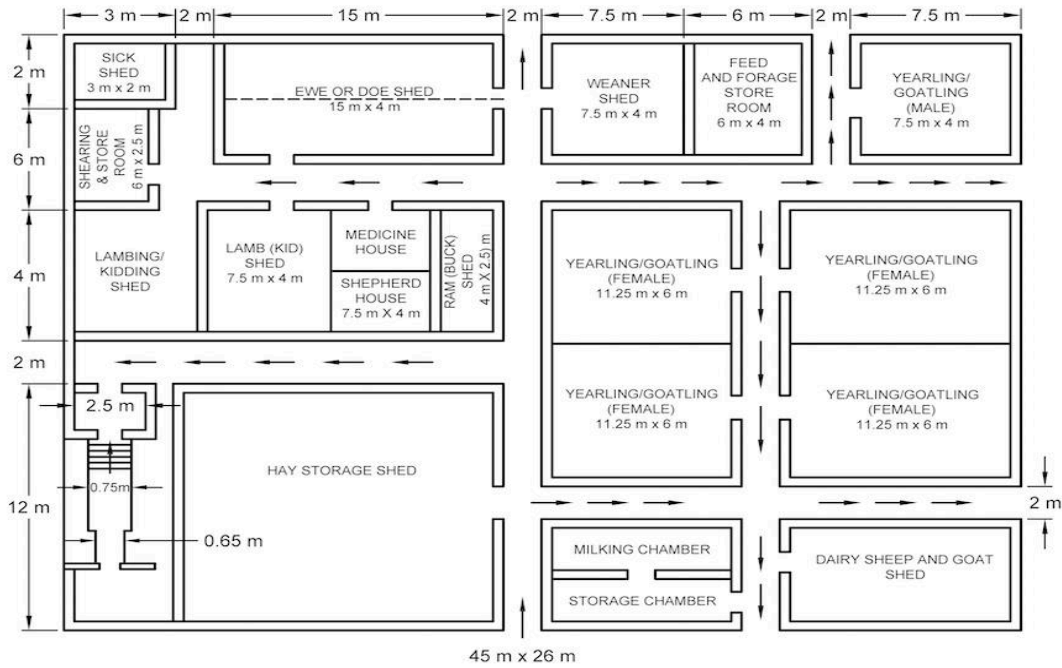
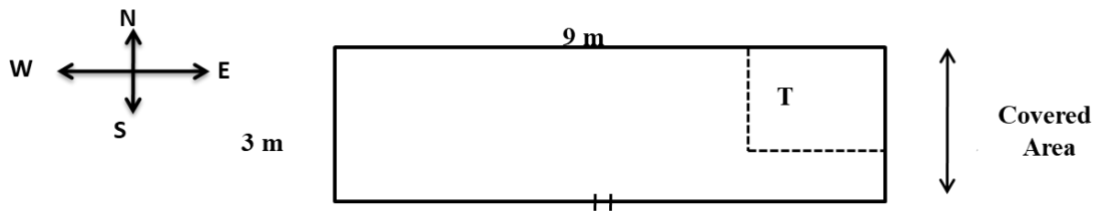
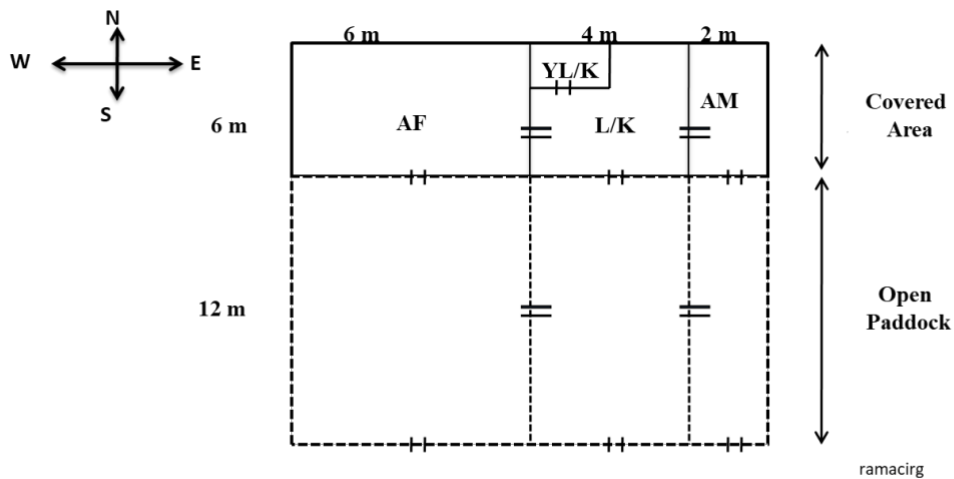

FIG. 1 GENERAL SKETCH OF SHEEP/GOAT SHED



Adult Females (10 Nos.); Adult Males (1 No.); Lambs/Kids (12 Nos.)  
 T – Temporary partition for young lambs/kids below 3 months

FIG. 2 FLOOR PLAN FOR 10+1 UNITS WITH FOLLOWERES



AF – Adult Females (25 Nos.); AM - Adult Males (3 Nos.);  
 L/K – Lambs/Kids (30 Nos.) YL/K – Small partition for  
 Lambs/kids below 3 months of age

FIG. 3 FLOOR PLAN FOR 25+2 UNITS WITH FOLLOWERES

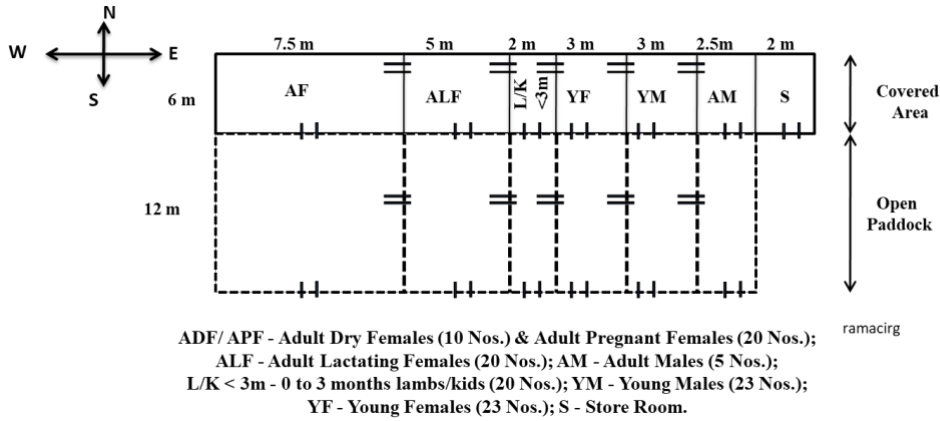

FIG. 4 FLOOR PLAN FOR 50+3 UNITS WITH FOLLOWERES

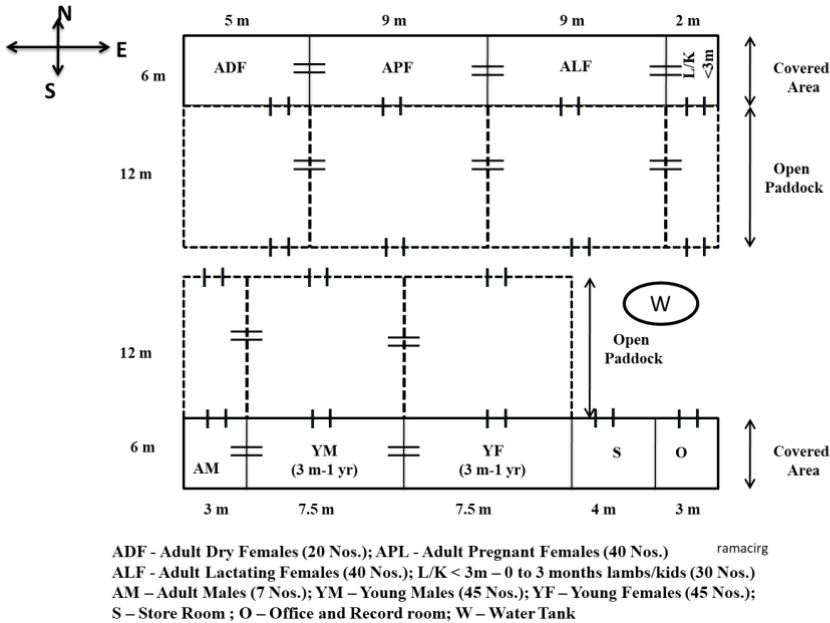
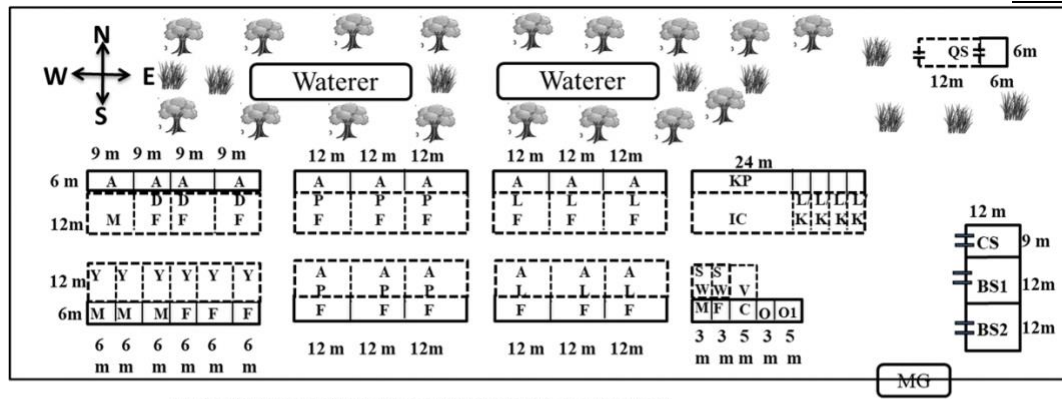
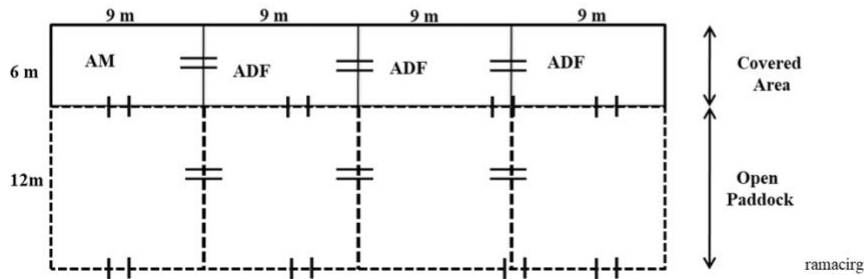

FIG. 5 FLOOR PLAN FOR 100+5 UNITS WITH FOLLOWERES



MAGNIFIED FLOOR PLAN OF FIRST SHED (AM AND ADF)



ALF-Adult Lactating Females (200 Nos. 35 in one paddock); L/K- kids < 3m: 0 to 3 months lambs/kids (300 Nos. 50 in one paddock); KPIC- Lambing/Kidding Pen with Individual Cages (40 No.); AM-Adult Males (25 Nos.); YM-Young Males (150 Nos. 50 in one paddock); YF-Young Females (150 Nos. 50 in one paddock); SWM-Sick Ward Male; SWF-Sick Ward Female; VC-Veterinary Clinic; O-Office for Supervisor and Records room; 01-Office for Manager; CS-Concentrate Store; BS1 and BS2-Bhusa Stores; QS Quarantine Shed; MG-Main Gate

FIG. 6 FLOOR PLAN FOR 500+25 UNITS WITH FOLLOWERES

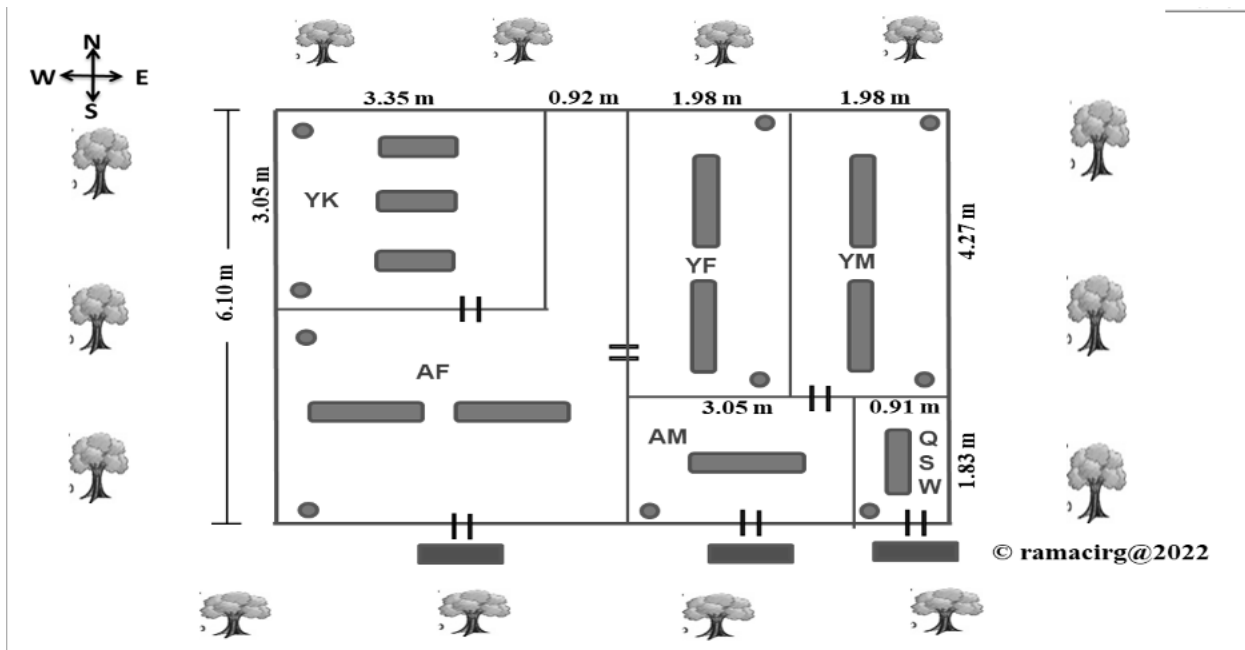

YK-Young Kids (0-3 m age, 20-25 Nos.), AF-Adult Females (>1 year age, 15 Nos), YF-Young Female kids (3-12 m age,, 11-12 Nos), YM-Young Male kids (3-12 m age, 11-12 Nos), AM-Adult Males (2-3 Nos), QSW- Quarantine/Sick/Weak ward (1-2 Nos).

FIG. 7 FLOOR PLAN FOR 15 GOATS WITH FOLLOWERES FOR HILL REGION



## **6 GENERAL CONSIDERATIONS IN HOUSING OF SHEEP AND GOATS**

### **6.1 General**

The sheep and goats reared in small flocks for nutritional and livelihood security needs minimal housing facilities following the scientific principles with low cost structures using locally available resources. After gaining practical experience of 2-3 years in rearing sheep and goats in a smaller scale, sheep and goat keepers should construct permanent shelters and expand their flock size for sustaining the existence of farms on a long run. Separate housing arrangements for different categories of animals viz. growers, pregnant females, lactating females, breeding males, etc. are to be ensured for rearing goats scientifically for harnessing maximum output sustainably. The housing structures required do vary for different flock sizes and even may vary for one type of flock size under different rearing systems. Therefore, before deciding the type of housing facilities required, one must know few basic facts in housing requirements for different age categories of goats, irrespective of flock size, rearing systems, agro-climatic regions etc. In semi-intensive rearing system, animals are generally let loose in the grazing area during morning and the open space facilitates with supply of drinking water for rest during the noon. Similarly, the animals under migratory management systems are grazed along the migratory routes in day time and housed in open fields during night hours using bamboo panels. However, sheep and goats reared under stall-fed/intensive rearing systems need permanent shelter structures.

In semi-migratory system, the animals are kept continuously on grazing for two days and kept at night in the open fields. Then they come back to their native village for watering. In grazing field, innovative low-cost 'YANGYA' type shed can be constructed for rest in semi-arid and arid regions, which facilitates heat dissipation and maintains relatively lower temperature at the ground level during grazing. Even portable light weight shade materials with supporting structures may also be tried in grazing field for young kids. Goat houses in hot weather environments with prevailing extensive production system are protected physically either with natural shade (trees) or artificial shade like temporary roof in open space using tent cloth or jute cloth materials in open paddocks that reduce radiant heat load on the animals resulting in improved feed intake and productivity. If the small flock is to be maintained on semi-intensive and intensive rearing in urban and peri-urban areas as a small scale livelihood model, the permanent shelter structures using iron, pillars, durable cemented sheet roof shall be tried. The ready to install permanent structures are also available in market for small goat farms.

### **6.2 Feeding and Watering**

The recommended ventilation space is adjusted to protect animals from cold stress using gunny bags/tarpaulin/thatch panels/sandwiched portable plastic panels having wool/polyurethane materials during cold weather conditions. The recommended feeding space of 0.30 m<sup>2</sup> to 0.35 m<sup>2</sup> and 0.40 m<sup>2</sup> to 0.50 m<sup>2</sup> for young and adult sheep/goats, respectively with watering space of one-tenth of feeding space per animal need to be provided for ensuring proper feed intake by avoiding aggressive behaviours while feeding in groups.

### **6.3 Basic Recommendations for Shelters**

**6.3.1** The recommended minimum shelter requirements as given in Table 3 need to be ensured while constructing shelters for sheep and goats as per flock size, season, or climatic zones. The orientation of shed should favour free air movement to remove moisture and ammonia odour inside the shelter. Considering the economics of shelter construction as well as structural stability,

general dimension of sheep and goat shelter should be 20 m × 6 m which will favour better group dynamics and normal expression of 30-40 sheep/goats per group in each partition.

**Table 3 Basic facts and Dimension of sheep and goat shelters**  
(Clause 6.3.1)

Sl. No.	Description	Scientific requirement/recommendation
(1)	(2)	(3)
1	Orientation of shed	Sheds with long axis running East-West with generous provision for ventilation/air movement to help dry up the shed will be most suitable.
2	Length of shed	No restriction on the length of shed.
3	Breadth of shed	Normally between 6 m to 8 m
4	Wall height	0.5-1.0 m above ground on long side of shed & up to roof on width side of shed.
5	Roof height	2.7 m at eaves & 3.5 m at centre.
6	Overhang of roof	0.75-1 m on both sides.
7	Gap between two sheds	6 m to 8m (Preferably not < 6 m).
8	Open paddocks	On one side of shed preferably south, if space constraints exits or on both side.
9	Partition within shed	The shed shall be partitioned lengthwise to form 2 or 3 or 4 equal compartments to accommodate 30-40 sheep/goats per group in each partition. Provision (gate) for crossing each partition in covered and open paddocks in all sheds should made available for efficient space utilization and time saving in farm operations.

**6.3.2** The dimension and types of sheds for each physiological stages like young animals, growing animals, adult animals, lactating animals, breeding animals vary with number of animals available in the farm, hence fixed dimensions for each shed is not recommended in the design and layout of sheep and goat shelter. However, the general diagram of low cost shed and side elevation is given in Fig.8. and the permanent shed and its side elevation is given in Fig.9., respectively.

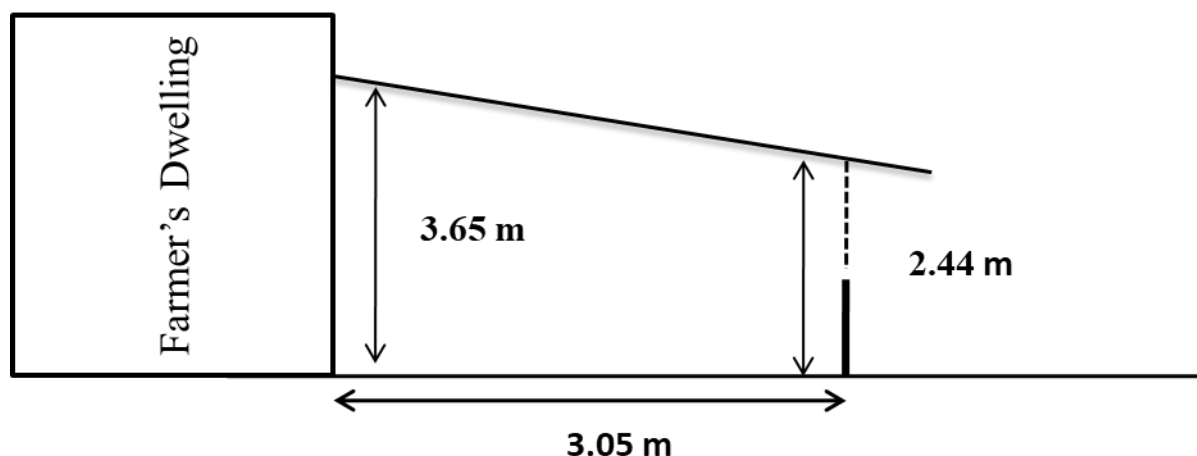

FIG. 8 GENERAL DIAGRAM OF LEAN TO TYPE LOW COST SHED

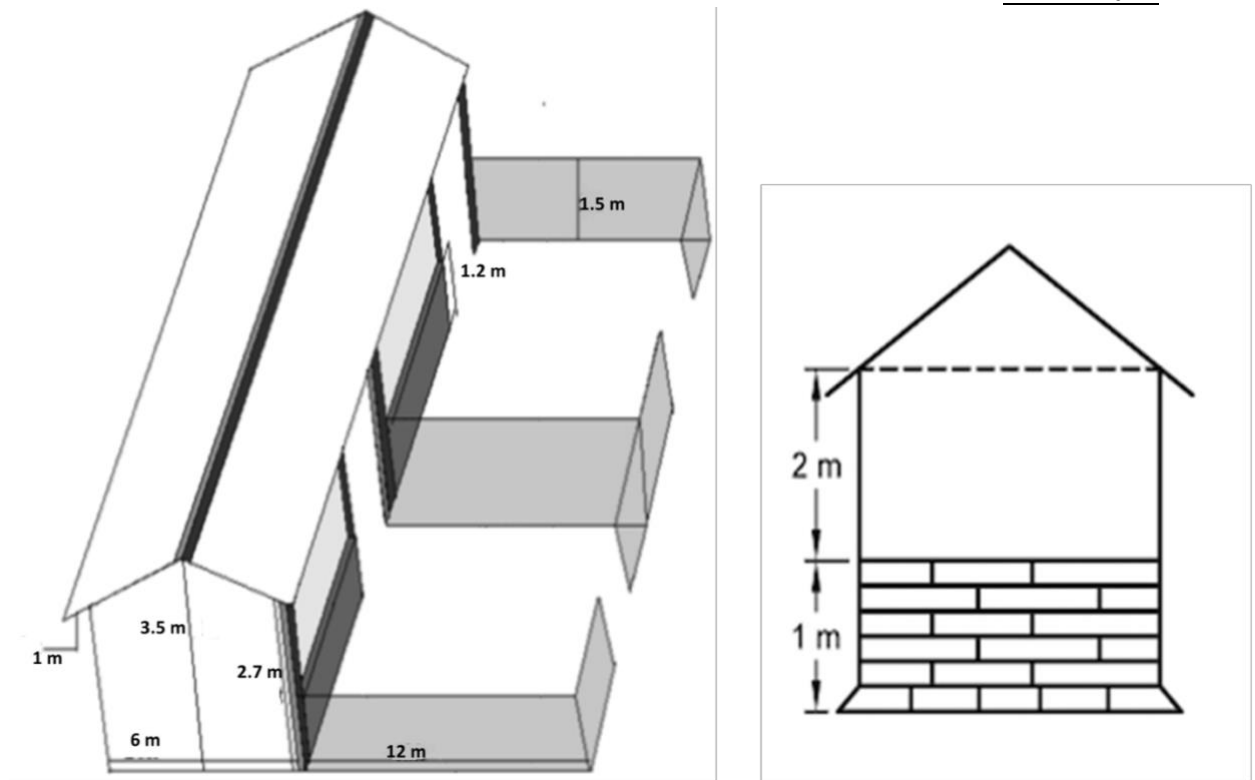

FIG. 9 GENERAL DIAGRAM OF PERMANENT SHED

#### 6.4 Recommendation for Lambing or Kidding Shed

Shed In lambing or kidding shed, individual cages of  $1.2\text{ m} \times 1.2\text{ m}$  should be fabricated in lengthwise of shed in two rows with the central passage of 2.6 m for providing individual care of young ones for first week after birth for suckling. The individual feeders should be hung in partition in cages. The waterers shall be arranged in central passage outside of individual cages. Lambs/kids are housed along with mothers for first week of life. Thereafter, kids/lambs are housed in groups of 30-40 animals in temporary enclosures having bedding materials in lambing/kidding shed itself as per the recommended floor space. After 3 months, again male and female animals are separated and reared in groups. The place of temporary enclosure in lambing/kidding shed are changed/rotated at monthly intervals to reduce coccidial load. In extensively or semi-intensively reared animals, lambs/kids are housed separately in enclosures and in some areas, kept in a dome made of bamboo or other locally available material during grazing hours. This prevents the young lambs/kids from straying or mixing with the flock, except during suckling. The dome is usually kept outdoors during the day if there is no rain.

In dairy sheep and goat shed, the shed shall consist of stalls for keeping milking doe. The stalls may be arranged in two rows with a passage in between them. The dimensions of each stall meant to keep a single milking doe may be 1.2 m wide and 1.4 m long.

#### 6.5 Recommendation for Storage of Wool, Feed and Fodder

**6.5.1** The shearing shed may consist of two compartments with a dividing wall. One should be open type for shearing the animals and the other for storing wool and shearing equipment. There shall be a wooden door one metre wide and two metres high in the front side of the room. It may also have two windows, one on each side of the long sides of the room. Each window may be 0.7 m wide and 1 m to 2 m high. The windows may be covered with wire-netting. One holding pen

for at least 30 sheep in front of the shearing shed and another holding pen behind the shearing shed may be provided to hold shorn sheep after shearing.

**6.5.2** The feed and fodder storage can be built separately in the vicinity of animal shed that facilitates ease of transportation to different units. The size may be different for different geographical regions aimed at storing the feed resources to feed during scarcity or concentrates and supplements to feed for maintain production.

## **6.6 Recommendation for Shepherd's House**

The shepherd's house may have two parts, one to accommodate storage facility for medicines and other appliances and the other for the caretaker, which shall be located at a convenient place in the shelter. There shall be a door one metre wide and two metres high on the long side of the shed facing the passage of the yard. The door leaf may be of wooden planks. There may be 4 windows; one of these facing the passage of the yard and the other three facing outside. Each window may be 0.7 m broad and 1.2 m high and covered with wire-netting

## **7 CONSTRUCTIONAL REQUIREMENTS OF UNITS**

Proper shelter design of sheep and goat units with recommended construction materials suitable to flock size, agro-climatic zones not only avert production loss but also optimises space utilisation and prevents diseases ensuring maximum production and welfare.

### **7.1 Floor**

**7.1.1** The floor type should favour hygiene with maximum comfort, lower dirt score on animals and worm load. Generally, soil or moorum (deep brown/red color soil mostly used in construction purposes) floor provides maximum comfort to sheep and goats, hence recommended normally in sheep and goat shelters. However, it varies with climatic zones. The soil/ sandy floor is recommended under hot dry conditions of arid or semi-arid areas and the floor level in covered area is kept 150- 300 mm above the farm road and the floor level in open paddocks is kept 150-300 mm down the covered area/main shed.

**7.1.2** A suitable drain should be provided at the end of the floor side. The depth of the drain should be 75 mm and width 300 to 400 mm.

**7.1.3** Lime dusting once in fortnight during rainy and peak winter season, loosening of hard soil once in three months, replacement of soil during summer months as per need preferably once in a year / two years after assessing the hardening of floor surface by dung cake formation is practicable economic measures to keep floor dry and control disease outbreak.

**7.1.4** The floor in lambing /kidding shed and lactating animals shed are to be provided with 100 mm thick bedding materials using locally available resources is recommended to protect them from cold stress and to prevent soil licking in new-born animals.

**7.1.5** The raised floor system (wooden/bamboo/customised plastic perforated flooring materials) is recommended in high rainfall and high humid areas to maintain the floor in dry conditions as far as possible, which is the thumb rule for proper shelter management in livestock farms. In the case of slatted flooring, the width of each wooden plank or slat shall vary from 50 to 100 mm and the thickness between 25 and 40 mm. The sides of the planks/slates shall be well rounded and the clearance (gap) between two planks shall range between 10 to 15 mm to facilitate the disposal of

dung and urine. The slatted flooring shall be constructed at a height of at least one metre above the ground level (one fourth of width of shed) to have easy cleaning but varies widely depending on the agro climatic conditions and production system. In this case, a suitable ramp or steps of bamboo/wooden/plastic planks shall be provided. If slatted floor materials are used at a height 150 mm from ground level, it can be used to replace conventional bedding materials in new-born, growing young and lactating animals sheds. The sheds with the raised slatted floors installed above 1.8-2.4 m ground level shall be easily used as two-tier vertical housing with animals housed in two floors for higher floor space use efficiency. The thin layer of fibre sheets are fixed in slanting position 150 mm below the slatted floor for easy removal of dung from outer side the shed. For hill regions of India, the wooden/bamboo/plastic slatted floor shall be fixed at 0.6 m above ground and would be installed as removable type so that slatted floor material shall be removed out for washing and drying in direct sunlight for disinfection purposes. This raised floor shall be used for storing dry fodders inside the shed as well as keeping sheep and goats.

**7.1.6** For the shearing room, store room, shepherd's room, office room, the flooring may be moorum or brick in cement mortar, and the floor shall be levelled properly. The floor in milking room, milk storage chamber, feed (concentrate/dry fodders) store should be made of cement concrete tiles (see IS 1237) with movable or immovable slatted wooden platform raised 450 mm above the ground. The floor shall have a slope of 25 mm for every 1 m. For each row of stalls, there shall be a brick masonry drain 300 to 400 mm wide and 75 mm deep.

## **7.2 Walls**

**7.2.1** The walls may be of brick in lime mortar up to two-third of their height from the floor level (*see* IS 1077 and IS 2212). The upper one-third portion of the walls may be of bird-proof netting especially for the lambing/kidding shed, newborn lamb/kid shed and sick animal shed. The chain-link netting may be supported by angle irons of size 50 mm × 50 mm × 6mm section and brick masonry columns placed alternatively at 1.5 m centre to centre. In the case of lamb or kid shed, the upper one-third part may be of wire netting supported by angle irons of size 50 mm × 50 mm × 6 mm at the four ends. The walls on the three sides of the shearing and store room may be of brick in cement mortar. The front wall (one of the broad sides of the room) may be of brick in cement mortar up to one-half the height from the ground level and the upper one-half portion may be of wooden battens or wire netting. However, in case of sheds with raised floor system, no side walls are constructed and raised floor is constructed with RCC pillars and only chain-link netting/wire mesh of different dimensions are supported by angle irons frame.

**7.2.2** The walls in milking room and storage chamber may be of brick in cement mortar up to 1.2 m in height and the rest of the portion shall be covered with wire-netting supported by angle irons of 50 mm × 50 mm × 6 mm section or wooden posts of suitable section. The walls of the stalls adjoining the passage shall be 1.5 m high and they shall be of brick in cement mortar.

**7.2.3** The walls in concentrate feed store shall be of brick in cement mortar up to roof without any gap between walls and roofing materials. The bird- and insect-proof wire mesh frames of 1.0 m x 0.5 m fixed at 1.0 m gap just 0.5 m below the roofing materials for free air movement inside feed store to avoid dampness.

**7.2.4** The walls in dry fodder (bhusa/crop residues) godown is similar to concentrate feed store except the front side wall is either not constructed or constructed in such a way that rain water entry is avoided inside the godown as well as large transport heavy vehicles carrying bhusa are entered inside godown and emptied easily.

**7.2.5** For hill regions of India, locally available stones shall be used for construction of walls instead of bricks up to two-third of their height from the floor level and upper one-third portion of the walls shall be made from strong angle iron railing on all four sides with gates to protect sheep and goats from predation. Bricks used in construction of walls shall be as per IS 12894, IS 13757, and IS 16720 based on the type of brick used.

### 7.3 Roof

**7.3.1** The different patterns of roof for livestock buildings are lean-to type, gable, monitar, semi-monitar, gothic arch, hip which suits the climatic conditions and type of roof ventilations desired.

**7.3.2** The common roof pattern in sheep and goat shelters are mostly lean-to or gabled type (see Fig. 10).

**7.3.3** The slope of the roof shall depend upon the rainfall and other climatic conditions of the region. Pitch is the degree of slope given to the sides of the roof. The pitch should be  $35^\circ$  for thatched roof,  $25-30^\circ$  for tiled roof and  $12-18^\circ$  for a sheet roof. The slope is generally kept steeper in heavy rainfall areas. The pitch should not exceed  $45^\circ$ . Pitch is calculated by dividing rise by double the run. In hot climates, rise should be smaller therefore lower the pitch that is desirable for tropical buildings to facilitate free ventilation. For cold climate, this should be vice versa.

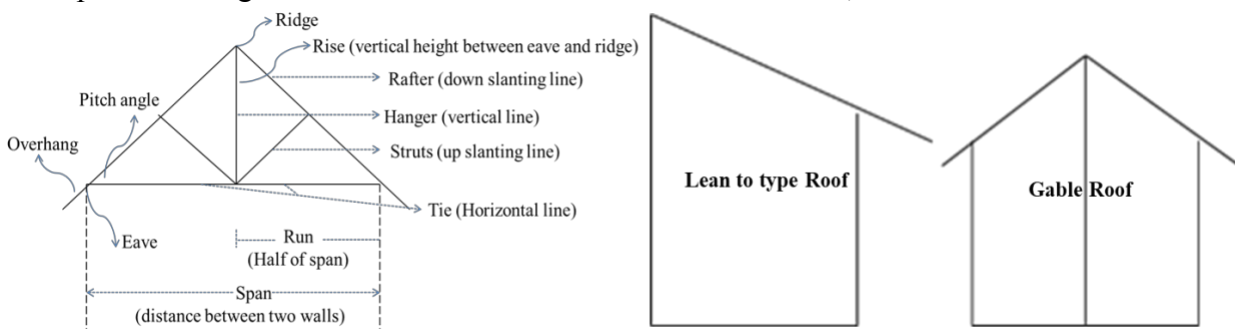

FIG. 10 ROOF TERMS AND COMMON ROOF TYPES

**7.3.4** The roof can be single sloped or double sloped. Single sloped roof can be used for small sheds up to a span of 3 meters, for houses where there won't be any day time accommodation of animals namely grazing sheep and goats. In single sloped roof, walls or supporting structures on one side is higher than the other and rafters are fixed directly on the opposite walls or posts. In this, roof ventilation is not possible.

**7.3.5** Double sloped roof is used in buildings having span of more than 3 meters. The rafters in this roof are fixed on roof truss/frames. The buildings having span of 4-6 m, up to 6 m, up to 9 m and more than 9 m, a collar beam truss, king-post truss, queen's truss and truss with multiple struts are respectively used. The type of trusses used depends upon the span of the buildings and weight of the roof coverings. The king-post truss has two rafters, one tie, one hanger and two struts. The queen's truss has two rafters, two ties, two hangers and two struts. Truss with multiple struts is usually made of steel having two rafters, one tie and multiple struts. Ridge ventilation is possible in double sloped roof in the form of continuous ridge opening and is an ideal roof pattern for tropical buildings for animals and for large buildings accommodating large number of animals. The double sloped roof having one slope overlapping the other at the ridge of the roof with a ventilating gap of 30 cm is called monitar roof. This is also suitable for tropical buildings and saves for the purpose of ventilation and lighting in the buildings. The hip roof or four-sided roof is more aerodynamic and inherently more resistant to uplift forces of high wind than gable end and other roof designs.

**7.3.6** The roof may be made of plain or corrugated galvanized iron sheets (*see* IS 277), aluminium sheets (*see* IS 737); asphalted corrugated, cemented corrugated, or plain light roofing material or thatch. In case the roof is thatched, the thatching shall be at least 150 mm in thickness and it shall be rain-proof and fire-proof. In heavy rainfall areas gunny sacks treated with cement-lime mixture (*see* 7.3.7) may be used with thatch. During summer, roofing structures are managed in such a way that it provides comfortable microclimate inside the shed. White painting of roof surface (outer side) and black in the inner side should be done in time to curtail radiation. The eaves of the roof shall project out sufficiently long to prevent the rain water entering into the shed.

#### **7.3.7 Preparation of Cement-Lime Mixture**

Stir thoroughly 12 parts by volume of cement and three parts by volume of lime (*see* IS 712) in 20 parts by volume of water. Add one part by volume of common salt (*see* IS 797) and one-half part by volume of alum (*see* IS 258) and stir until all ingredients are well mixed. Apply the mixture evenly with the help of a brush on the inner surface of the gunny sack. Give two coats of the mixture on the outer surface of the gunny sack. Stretch the gunny sack and dry in the sun until it becomes stiff.

### **7.4 Gate**

**7.4.1** Each shed as well as each partition may be provided with one or more gates both in covered area and open paddocks either on the long or broad sides of the sheds depending upon the dimensions (*see* Fig.1) of the shed. The dimensions of each gate may be 0.8 m broad and one metre high, however, the dimensions of gate may vary with the type of shed/room used for different purposes. Horizontally or vertically sliding gate in sheds shall also be used to avoid injury to workers, sheep/goats as well as to save space needed for opening and closing of hinged gates. The sliding gates are more preferred in lamb/kids shed, individual cages, sheds with smaller dimensions recommended for hill regions.

**7.4.2** The recommended minimum width of shed gates and farm gates are 1.2 m and 2.5 m with single and double hinges, respectively. Hinged gates are better in animal farms and is suspended to a hanging post by hinges and closed by shutting post by a hasp and staple. The dimension of gate should allow free movement of feeders, waterers, wheel barrows, carts, vehicles inside the shed/farm gates, farm roads, feed and *bhusa* godown for carrying out various farm operations efficiently. The gate leaf and frame may be made of wooden battens, iron wire mesh fitted in angle iron frame. It shall fit the entrance closely.

### **7.5 Feeders and Waterers**

**7.5.1** The sheds or partition in each shed for all animals in farm should have provision of feeders for feeding and waterers for watering at shoulder point height of animals. However, the waterers should be away from feeders to avoid water spillage over feeding materials leading to feed wastage as sheep and goats prefer dry form of feed over wet form.

**7.5.2** The feeder may be made of locally available resources like wood, cement concrete, iron, plastic materials for providing feed and fodders. The feeder may be of constructed along the side walls with iron railing inside shed as well as in open paddock as fixed type or feeders shall be of portable type. The dimensions and type of feeder required depends on space availability in shed, age, and sex of animals.

**7.5.3** The feeding rack in the feeder should be at the average shoulder point of animals in a group so that animals shall be able to consume feed comfortably without contamination and wastage. The feeder may be raised within the height ranging between 450 mm and 600 mm from the ground depending upon the shoulder point height of different breeds in farms.

**7.5.4** The feeder may also be constructed as a raised wooden frame with openings to fit galvanized steel pails for keeping feed and water for goats. It may be constructed in the partition walls and be supported on iron or wooden brackets. The place to keep hay and other greens may be in the form of a rack fixed in the front wall from where the animals could pull out the greens when they require.

**7.5.5** The water trough may be of cement concrete or galvanized steel pails or aluminium or plastic buckets and may be fixed or hung from a hook fixed to the walls. The waterers shall be kept away from feeders in shed for intensively reared animals. If animals raised on extensive or semi-intensive system, the waterer made of brick and cement wall of rectangular shape shall be constructed in farm premises near the gate, where animals are leaving for grazing.

## 7.6 Partitions

The partitions may be made from wooden planks, half-cut bamboo, galvanised iron wire mesh in angle iron frame fixed on brick in cement mortar wall, galvanized steel sheets etc. The partition shall be at least 150 mm above the floor level and not more than 1 m high from the floor. In the partition, there should be a gap of 100 mm to 150 mm between each bamboo or wooden plank or wire mesh to enable the animals to see one another

## 7.7 Dipping Tank

The dipping tank, to protect the animals from infection, may be made either of galvanized steel sheets or constructed of stone or brick in cement mortar, according to local conditions. The dimensions of a typical tank may be as given in Fig. 12. If a galvanized steel tank is used, it shall be well bedded down and the soil rammed tight against it to prevent the sides of the bath from bulging when it is filled. If the base of the solid is unstable, the tank may be bedded in cement concrete. The dipping tank may be at one side of the farm.

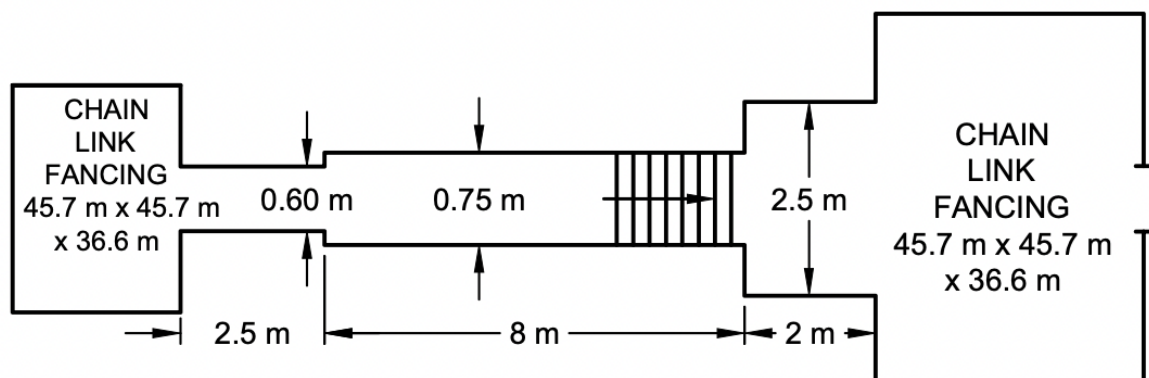

FIG. 12 DIPPING TANK

## 7.8 Foot-bath



Foot bath is a tank generally measuring 6 m × 3 m at the bottom, 12 m × 4 m on top, 0.3 m deep constructed near entrance of gate in shed or main entrance of the farm to protect the animals from contagious diseases like foot rot as well as pests. A foot-bath made of galvanized steel sheets, or brick in cement mortar shall be provided at the entrance to the yard. These baths may be embedded in the soil suitably and filled with germicidal solution. Animals, personnel, carts entering and leaving farm have to wade through this solution and in the process, personnel and animals' feet or wheels of the vehicles get disinfected.

### **7.9 Lighting**

Provision for lighting should be made. A 7 W LED for each 10 m<sup>2</sup> floor space or 15 W bulb for 25 m<sup>2</sup> space or equivalent fluorescent tube light should be provided.