

BUREAU OF INDIAN STANDARDS**DRAFT FOR COMMENTS ONLY**

(Not to be reproduced without the permission of BIS or used as an Indian Standard)

भारतीय मानक मसौदा
पराबैंगनी जल कीटाणुशोधन प्रणाली — विशिष्टि
(*आइ एस 14724 का पहला पुनरीक्षण*)

Draft Indian Standard

ULTRAVIOLET WATER DISINFECTION SYSTEM — SPECIFICATION

(*First Revision of IS 14724*)

ICS 11.080.99

Water Purification System Sectional
Committee, FAD 30

Last Date of Comments
1 /12/2024

FOREWORD

(*Formal Adoption clause would be added later*)

The quality of water available for human consumption has a bearing on health of the population/community. Water may have foul odour, colour, turbidity, taste and most seriously, pathogenic microorganisms, which are hazardous to health. Solids in suspension can cause both colour and turbidity. The presence of pathogenic microorganisms is most dangerous, both because they are not visible to the naked eye and can cause ailments, which can prove fatal.

For purifying water of its microbiological impurities, the traditional methods have been boiling, chlorination, filtration and ultraviolet disinfection. Of late, various other techniques such as ultrafiltration, reverse osmosis, ozonation, etc. are being used. Each method has its merits and demerits and the choice of method is based on different parameters, such as water source, turbidity, level of total dissolved solids, power supply, cost and so on. Use of ultra-violet emission for disinfection is one of the time-tested and effective-techniques for microbial inactivation. UV light does not necessarily kill pathogens; it damages DNA and RNA to prevent them from replicating.

This standard was first published in 1999. This revision is undertaken to update the standard in line with the latest technological developments. In this revision, the following major changes have been incorporated:

- a) In the terminology clause various new terms have been incorporated to bring out more clarity in the standard such as contaminant, disinfection, feed water, effluent, influent challenge water

and turbidity.

- b) LED based technology has been considered and suitably incorporated in the standard.
- c) Challenge organism *Sarcina lutea* (*Micrococcus luteus*) for evaluating microbiological reduction has been replaced with MS2 and Qbeta coliphages considering that MS2 coliphage is one of the more resistant microorganisms, suitable to be used for UV based systems operating at 254nm and for wavelengths other than 254nm, Qbeta coliphage is the bacteriophage of choice which gives a linear dose response reaction.
- d) The figures have been replaced with schematic representation of different systems.
- e) Method of test for microbiological reduction have been elaborated to incorporate details of influent challenge water preparation.

Though UV light is capable of inactivating large range of microbes, for efficient disinfection water should be free from suspended and colloidal substances causing turbidity. Also, water should not contain light absorbing substances such as phenols, alkyl benzene-sulphonate (ABS) and other atomic compounds.

It is important to note that water disinfection system will help in inactivating only the microbes, and will not filter any dissolved solids or chemicals.

For the purpose of deciding whether a particular requirement of this standard is complied with, the final value, observed or calculated, expressing the result of a test or analysis, shall be rounded off in accordance with IS 2: 2022 'Rules for rounding off numerical values (*second revision*).' The number of significant places retained in the rounded-off value should be the same as that of the specified value in this standard.

The draft revision of this standard was earlier issued into wide circulation (WC) on 27 Oct 2024 with 60 days commenting period. The committee in its 10th meeting agreed to the changes recommended in the draft considering the comments received on the draft. Accordingly, the following major changes have been incorporated in the draft and the draft is being issued into second wide circulation:

- (i) The scope of the standard has been modified to include systems upto a flow rate of 3 litres per minute.
- (ii) Electric supply for the system has been specified as 220V \pm 10%, 50Hz for single phase.
- (iii) The requirement of turbidity reduction and chlorine reduction has been removed considering that these are not applicable to test the performance of UV system.
- (iv) Turbidity of the test water is prescribed as the maximum operable turbidity declared by the manufacture considering the direct correlation of turbidity to UV efficiency. The marking clause has also been modified accordingly to include maximum operable turbidity.

ULTRAVIOLET WATER DISINFECTION SYSTEM — SPECIFICATION

1 SCOPE

1.1 This standard covers systems employing Point of Use (PoU) ultraviolet technology for disinfection of water systems up to a flow rate of 3 litres per minute (LPM). The system is expected to give water free from water borne pathogens, which is safe and suitable for human consumption.

1.2 The standard does not cover requirements for consumables, such as filters and treatment media.

2 REFERENCES

The standards listed below contain provisions, which, through reference in this text, constitute provision of this standard. At the time of publication, the editions indicated were valid. All standards are subject to revision, and parties to agreements based on this standard are encouraged to investigate the possibility of applying the most recent editions of the standards listed below:

<i>IS No.</i>	<i>Title</i>
IS 302 (Part 1): 2008	Safety of household and similar electrical appliances: Part 1 General requirement (<i>sixth revision</i>)
IS 3025	Methods of sampling and test (physical and chemical) for water and wastewater:
(Part 10): 2023	Turbidity (<i>second revision</i>)
(Part 25): 1986	Chlorine demand (<i>first revision</i>)
IS 4905: 2015/ ISO 24153 : 2009	Random sampling and randomization procedures (<i>first revision</i>)
IS 10500: 2012	Drinking water — Specification (<i>second revision</i>)
IS 16240: 2023	Reverse osmosis based point-of-use water treatment system for drinking purposes — Specification (<i>first revision</i>)

3 TERMINOLOGY

For the purpose of this standard, the following definitions shall apply.

3.1 Contaminant - Any undesirable physical, chemical, or microbiological substance or parameter in water that may have adverse effects on health or aesthetics, or both.

3.2 Drinking Water - Water from any source, which is intended for human consumption, both, drinking and cooking purposes (*See IS 10500*).

3.3 Disinfection - The act of eliminating disease causing microorganisms from contaminated water either by exclusion or by killing/inactivating them.

3.4 Feed Water - Water entering into the system, which is to be treated.

3.5 Effluent - The treated water at the outlet of a unit, system, component, or process.

3.6 Influent Challenge Water — The standard test water with specified contaminants entering a system for evaluation.

3.7 Microbiologically Unsafe Water - Water that is known to contain disease-causing bacteria, viruses, protozoa.

3.8 Operating Pressure

3.8.1 Minimum Operating Pressure

The minimum input feed water pressure required for the disinfection system to deliver the desired rate of flow as declared by the manufacturer.

3.8.2 Maximum Operating Pressure

The maximum input feed water pressure permissible for the disinfection system to work properly as declared by the manufacturer.

3.9 Point-of-Use (PoU) Drinking Water Treatment System — A plumbed-in or faucet mounted system used to treat the feed water for direct consumption or use, hereinafter referred to as ‘system’.

NOTE — PoU UV systems are not intended for distribution.

3.10 Turbidity - A condition caused by the presence of suspended and/or colloidal matter, which results in the scattering of light rays.

3.11 UV radiation – Ultraviolet (UV) radiation is a form of non-ionizing radiation that is emitted by UV source at the wavelength of full UV range or a specific wavelength, which will be used for disinfection.

3.12 UV Source – Which generates the Ultraviolet (UV) radiation when energized.

4 DESIGN AND CONSTRUCTIONAL REQUIREMENTS

4.1 Inlet Port - The system’s inlet port shall be so designed that it can be suitably connected to the feed water source.

4.2 Method of Mounting

The system shall facilitate wall mounting, tabletop mounting, under the counter or any other suitable mounting as prescribed by manufacturer in the user manual.

4.3 Main Components

4.3.1 The UV disinfection system shall have the following components:

- a) Sediment/ Pre-filter — A filter required to remove physical impurities in the form of suspended solids like dust, dirt, silt and other fine particles from the feed water.
- b) Carbon filter — Required for the removal of chlorine and organic matter from feed water.

- c) Optimal UV transmitting medium (Quartz, Specific UV transmitting Fluoro-Elastomeric Polymer, etc.)
- d) Indicator of proper functioning of UV lamp/ UV LED/ any other UV source
- e) UV lamp/ UV LED/ any other UV source
- f) UV chamber/ UV Module/ UV reactor
- g) Solenoid valve with auto-cut off/Shut off mechanism/No pass system

NOTE — Combination of Sediment & Carbon or any other filtration technology may also be used.

4.3.2 The UV Disinfection system may have the following additional components (non-exhaustive list):

- a) Ultrafiltration/ Microfiltration/Any other technology or combination of technologies
- b) Pump
- c) LPS or equivalent to detect the inlet pressure
- d) HPS or equivalent to detect the maximum pressure of the system
- e) Flow controller
- f) Storage tank
- g) Float switch or equivalent to auto shut off the system
- h) Voltage stabilization circuit, and
- j) Flow switch

NOTE- In case the feed water pressure exceeds the limit as declared by the manufacturer, a flow controller mechanism needs to be provided by the manufacturer as stated in the user manual.

4.4 The recommended UV dosage for disinfecting contaminated water is $40\,000\ \mu\text{W}\cdot\text{sec}/\text{cm}^2$ at the fail-safe point and for potable water it is $16\,000\ \mu\text{W}\cdot\text{sec}/\text{cm}^2$ at 50 percent of the UV lamp's normal output.

4.5 Materials of Construction

Those surfaces of the metal components of the disinfection system, which are expected to get wetted by the flow of water through the disinfection system, shall be made of corrosion-resistant materials or shall have a corrosion-resistant treatment or coating of food grade quality. The manufacturer shall ensure the same through a supplier's certificate or declaration.

4.6 Power Supply

The system shall work on electrical supply of $220\text{V} \pm 10\%$, 50Hz for single phase.

4.7 Maximum Rate of Flow

The system shall be designed to deliver disinfected water at the maximum flow rate of 2LPM or as declared by the manufacturer (whichever is higher).

4.8 Indications and Protections

4.8.1 An indicator should be provided to show the power supply being 'ON' and the same should be clearly mentioned in the user manual.

4.8.2 The system should be equipped with an ‘Alert’ and ‘No Pass’ mechanism to stop the water flow in case of any failures of the UV source as per the manufacturers recommendation in the user manual.

4.8.3 The system should be equipped with an indicator and a no pass mechanism to stop the water flow in case of any pre heating time required for effective functioning of UV source as per the manufacturers recommendation in the user manual.

5 PERFORMANCE AND SAFETY REQUIREMENTS

5.1 Type Pressure Test (Hydrostatic Test)

All the components of the UV system through which the water passes shall pass the hydrostatic test as prescribed in Annex A.

5.2 Routine Pressure Test (Pneumatic Test)

Compressed air at a pressure 0.2 MPa is fed through the inlet point of the device keeping all the outlets shut. After the pressure reaches the maximum as declared by the manufacturer, the airline is isolated by a manual valve and checked for a drop in pressure over 3 minutes. If the pressure is sustained, then this is found to be free from any leak.

5.3 Verification of Maximum Rate of Flow

5.3.1 The test for verifying the maximum rate of flow shall be conducted by collecting the effluent water from the disinfection system into a calibrated volumetric measure alongside a count of time using a timer.

5.3.2 The maximum rate of flow test shall be carried out at the maximum operating feed pressure as declared by the manufacturer in the user manual.

5.4 Test for Microbiological Reduction

The system shall meet the requirement given in Table 3 for microbiological reduction when tested as per the method prescribed in Annex B.

Table 3 Microbiological Reduction
(Clause 5.4)

Challenge Organism	Influent Challenge Level	Log Reduction Value (<i>min</i>)	Percent Reduction
MS2 coliphage (for UV systems operating at 254nm)	5.0 x 10 ⁴ to 5.0 x 10 ⁵ pfu/ml	4	99.99
Qbeta coliphage (for UV systems operating at wavelength other than 254 nm)	5.0 x 10 ⁴ to 5.0 x 10 ⁵ pfu/ml	3	99.9

5.5 Electrical Safety

5.5.1 The system shall not have excessive leakage current when tested in accordance with **13** of IS 302 (Part 1).

5.5.2 The system shall be able to withstand high voltage test when tested in accordance with **13** of IS 302 (Part 1).

5.5.3 The system shall have provision for earthing in accordance with **27.5** of IS 302 (Part 1). All parts of metallic construction shall be permanently and reliably connected to an earthing termination within the UV system and shall be free of rough or sharp edges or other hazards that may cause injury to persons adjusting, servicing, or using the system.

NOTE — Class II appliances and Class III appliances shall have no provision of earthing.

5.6 Safety Against UV Exposure

The UV chamber or the body of the disinfection system shall be such an enclosure, that the user does not get exposed to the UV light during the normal usage of the disinfection system as defined by the manufacturer.

6 SAMPLING AND CRITERIA FOR CONFORMITY

Representative samples of the material for ascertaining conformity to this standard shall be drawn according to the sampling plan prescribed in Annex C.

7 PACKING

The UV system shall be suitably packed in order to avoid damage during transit and storage.

8 MARKING

8.1 A suitable label shall be fixed on the body of the disinfection system, at a conspicuous location. The label shall be marked with the following details:

- a) Name and address of the manufacturer;
- b) Brand name;
- c) Production serial number;
- d) Model name or code;
- e) Minimum feed pressure;
- f) Maximum feed pressure;
- g) Maximum flow-rate in LPM;
- h) Maximum operable turbidity in NTU;
- i) Rating of UV source in watts or μ watts; and
- j) Life of UV source in hours

8.2 A user manual for the proper method of operation and maintenance of the disinfection system shall be provided in the form of physical or digital copy along with the disinfection system. It shall also include the life and specification of UV source.

8.3 BIS Certification Marking

8.3.1 The product may also be marked with the Standard Mark.

8.3.2 The use of the Standard Mark is governed by the provisions of the *Bureau of Indian Standards Act, 2016* and the Rules and Regulations made thereunder. The details of conditions under which the license for the use of Standard Mark may be granted to manufacturers or producers, may be obtained from the Bureau of Indian Standards.

ANNEX A

(Clause 5.1)

HYDROSTATIC PRESSURE TEST

A-1 Hydrostatic pressure test of the completely assembled UV system shall be conducted depending on the type of systems. Refer **Fig 1** Flow path of wall mounted/tabletop UV System without storage tank, **Fig 2** Flow path of wall mounted/tabletop UV System with storage tank, **Fig 3** Flow path of under-counter UV without tank and **Fig 4** Flow path of under-counter UV System with Hydropneumatic tank.

A-2 WALL MOUNTED/TABLETOP & UNDER COUNTER WITH OR WITHOUT STORAGE TANK UV SYSTEMS

A-2.1 The components of the UV system from the inlet port up to the tank/ tap will see similar pressure depending on the filter condition. The UV system shall be subjected to hydrostatic pressure at 1.5 times of the maximum input water pressure as recommended by the manufacturer.

A- 2.2 Before commencing the test, attach an open/close valve followed by a non-return valve (NRV) at a point before the end of the booster pump inlet. Connect the system to test water through using a manual pressurization pump.

A- 2.3 In case of systems with storage tank, flush the system initially with available tap water (<1 NTU turbidity), allowing at least 4 to 5 liters of purified water to flow or fill in the tank.

A-2.4 Isolate the tank with a ball valve just before the storage tank. Then close the open/close valve and slowly increase the pressure at a constant rate to reach 1.5 times of maximum recommended pressure in 5 minutes. Hold at this pressure for 15 min and observe the components and tubing at joints. There shall not be any leakage of water, water bubbles or hissing noise when the pressurization is held for 15 minutes. Release the pressure by opening the open/close valve and turning off the pressurization pump.

A-3 UNDER COUNTER (HYDROPNEUMATICS STORAGE TANK) UV SYSTEMS

A-3.1 The components of the UV system from the inlet port up to the tank/ tap will see similar pressure depending on the filter condition. The UV system shall be subjected to hydrostatic pressure at 1.5 times of the maximum input water pressure recommended by the manufacturer.

A-3.2 Before commencing the test, attach an open/close valve followed by a non-return valve (NRV) at a point before the end of the booster pump inlet. Connect the system to test water through using a manual pressurization pump.

A-3.3 Initially, flush the system with available tap water (<1 NTU turbidity), allowing at least 4 to 5 liters of purified water to fill in the hydropneumatic tank.

A-3.4 The testing requirement is 1.5 times of the pressure of the hydropneumatic tank declared by the manufacturer of maximum operating pressure of UV system or whichever is higher. The pressurization has to be done by closing the water faucet or tap emerging from the tank. The pressurization shall be increased slowly at a constant rate to reach the testing pressure in 5 min and

held at that pressure for 15 min. There shall not be any leakage of water, water bubbles or hissing noise, from the storage tank inlet when pressurization is held for 15 min. Release the pressure by opening the open/close valve and turn off the pressurization pump.

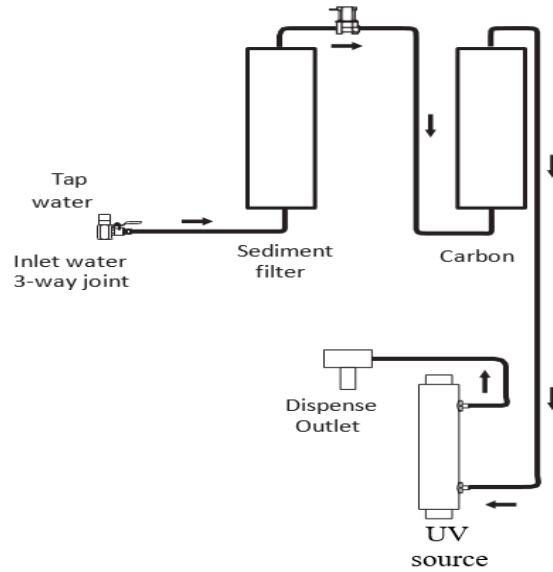

FIG. 1 WALL MOUNTED/TABLETOP UV SYSTEM WITHOUT STORAGE TANK

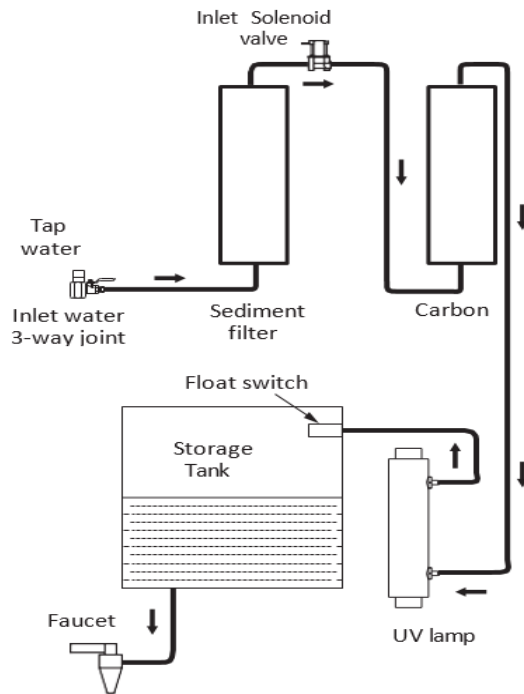

FIG. 2 WALL MOUNTED/TABLETOP UV SYSTEM WITH STORAGE TANK

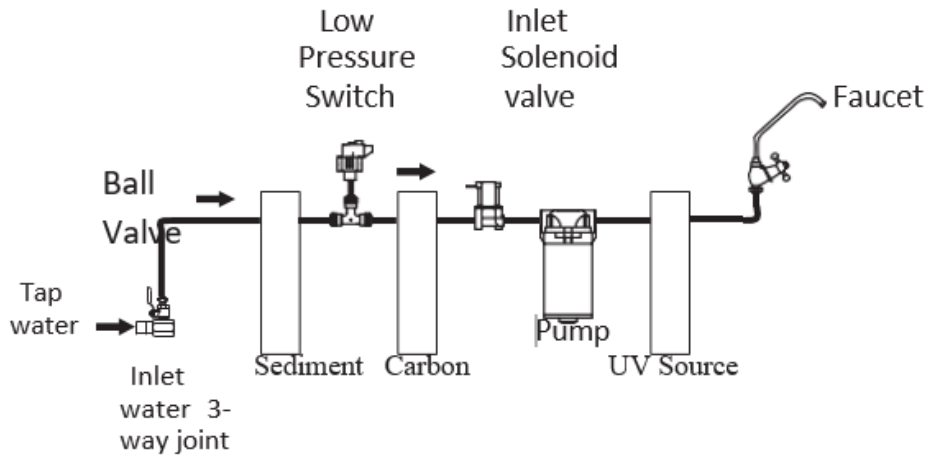

FIG. 3 UNDER THE COUNTER UV SYSTEM WITHOUT TANK

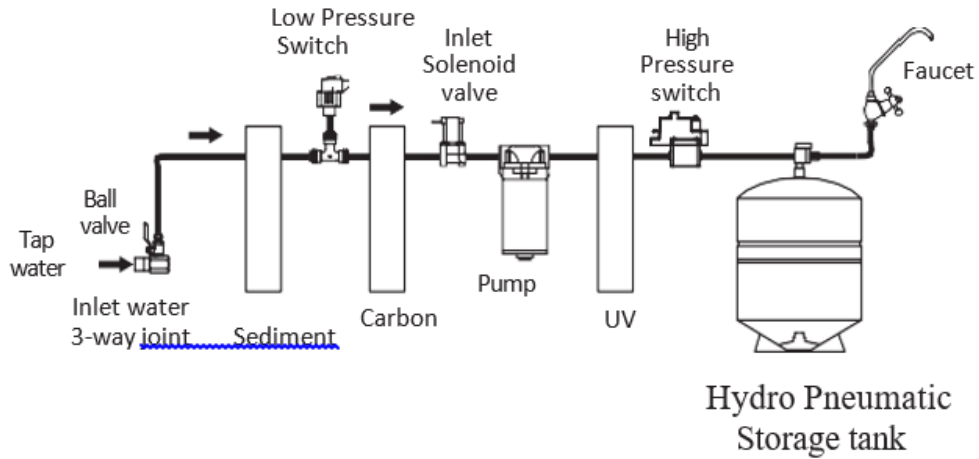

FIG. 4 UNDER THE COUNTER UV SYSTEM WITH HYDROPNEUMATIC TANK

NOTE: The above figures 1, 2, 3 & 4 are only for representation purpose, which may vary based on the configuration and technology.

ANNEX B

(Clause 5.4)

TEST FOR MICROBIOLOGICAL REDUCTION PERFORMANCE

B-1 EVALUATION OF MICROBIOLOGICAL REDUCTION

B-1.1 The disinfection system shall kill or inactivate all types of disease causing microorganisms from the water.

B-1.2 MS2 and Qbeta (Q β) coliphages shall be used as challenge cultures to evaluate the efficiency of the UV purification device based on the wavelength of UV being used in the system.

B-1.3 Two fresh UV purification systems shall be used for virus reduction testing.

B-2 GENERAL TEST WATER

Chlorine free general test water with the following characteristics shall be used:

Sl. No.	Test Parameter	Required value
1	pH	7.5 \pm 0.5
2	Temperature	25° \pm 2° C
3	Total Dissolved Solids (TDS)	200 – 500 mg/L
4	Turbidity	Maximum operable turbidity (as declared by manufacturer)
5	Free Available Chlorine (FAC)	\leq 0.1 mg/L

NOTES:

1 TDS may be adjusted by addition of NaCl (to raise TDS) or with RO treated/deionized water (to lower TDS). pH may be adjusted using dilute HCl or NaOH solution.

2 If there is high bacterial load in the tap water which may interfere with test organism, RO/DM/DI water may be used for test water preparation.

B-3 MICROORGANISMS

B-3.1 Viral Challenge for UV Mercury Lamp (wavelength 254nm)

- a) MS-2 coliphage (ATCC #15597-B1)
- b) *Escherichia coli* (ATCC #15597 host strain for MS-2)

B-3.2 Viral Challenge for UV LED and other than 254nm Range

- a) Q-beta coliphage (ATCC # 23631-BI/ DSM # 13768)
- b) *Escherichia coli* (ATCC # 23631/DSM 5210) host strain for Q-beta

B-4 EQUIPMENT AND ACCESSORIES

- a) Autoclave
- b) Incubator
- c) Laminar air flow/Biosafety Cabinet
- d) Vortex mixer
- e) Vacuum pump
- f) pH meter
- g) UV-Vis spectrophotometer
- h) Centrifuge
- j) Refrigerator
- k) Water bath
- m) Colony counter
- n) 0.45 μ membrane filters
- p) 0.22 μ sterile polycarbonate membrane filters
- q) Sterile filtration apparatus
- r) Sterile syringes and forceps
- s) Pipettes
- t) Petri dishes

B-5 REAGENTS AND MEDIA (for both phages and corresponding hosts)

- a) Sterile Phosphate buffer saline (pH 7.4)
- b) Tryptic Soy broth (TSB), pH 7.3
- c) Tryptic Soy agar (TSA), pH 7.3
- d) 1% Tryptic Soy Agar Medium (Soft TSA/Overlay agar), pH 7.3

All reagent ingredients, dehydrated media are to be dissolved by boiling, adjusted to final pH, and autoclaved at 120 °C and 15 psi for 20 min.

B-6 VIRAL INFLUENT CHALLENGE WATER

B-6.1 Based on the UV technology, between the two enlisted below, one phage will be selected for the test:

UV Light Wavelength	Test bacteriophage	Phage Count
254 nm (mercury lamp)	MS-2 <i>Coliphage</i> ATCC #15597-B	5×10^4 to 5×10^5 pfu/MI
Wavelengths other than 254nm (e.g 260-265nm, LED lamp)	Q- β <i>Coliphage</i> ATCC #23631-B1	5×10^4 to 5×10^5 pfu/mL

B-6.2 Viral Stock culture preparation

This section describes the propagation and harvesting methods for stock suspensions of MS2 & Qbeta coliphages for use as a challenge suspension. The stock preparation procedure may have to be repeated multiple times to achieve the required number of the said coliphage in the challenge water. Method to be followed is as below:

- a) One day prior to preparation of the phage MS2/Q β stock, thaw a cryogenically frozen corresponding *E. coli* host strain as provided in section D-3.1 & D-3.2. Inoculate one TSB tube with 0.1 ml of the stock suspension and incubate at 37°C for 15-18 h.
- b) For preparing MS2/Q β coliphage stock, liquefy 1% TSA and temper the media in a 45°C water bath. Prepare 1.5% TSA plates, which should be at room temperature prior to use.
- c) Prepare serial dilutions of MS2/Q β coliphage suspension in sterile PBS. Plate 10⁻⁵ to 10⁻¹² dilutions by plating in duplicate on 1.5% TSA plates. In a sterile tube, transfer 1 ml of diluted MS2/Q β coliphage. Then add 0.1 ml of the corresponding *E. coli* host, mix well, add ~ 5 ml of melted 1% TSA. Vortex to mix inoculum and media. Pour on the 1.5% TSA basal plates, with gentle rocking to spread the inoculum evenly. After the 1% TSA layer has solidified, the plates are inverted and incubated at 37°C for 15-18 h.
- d) Select the plates that show complete lysis of host bacterial cells by the respective phages. Flood the surface of each plate with 3 ml of TSB and remove the 1% TSA layer gently using a cell scraper. Pour the contents into two sterile 50 mL centrifuge tubes and make up the total volume to 40 mL with TSB. Add 0.2 g EDTA and 0.026 g lysozyme to each tube. Incubate at room temperature for 2 h, mixing every 15 min.
- e) After incubation, the tubes are centrifuged at 9280 x g for 5 min, or 2320 x g for 20 min, at 20°C. Collect the resulting supernatant taking care to avoid the pellet. A sterile 47 mm filtration assembly with a 0.22- μ m polycarbonate filter is aseptically constructed. Wash the filter with 10 ml of TSB broth just prior to the filtration to minimize the coliphage adsorption to the filter. Filter the supernatant.
- f) The MS2/Q β coliphage suspension is to be titrated as described in **C-6.3**. The concentration of the coliphage should be between 10¹⁰ and 10¹² pfu/ml.

B-6.3 Quantification of MS2/Qbeta Coliphage plaques

- a) Thaw cryogenically frozen *E. coli* host strain (respective strain for the two phages as provided in D-3.1 & 3.2) and inoculate 0.1 ml of the stock suspension in a TSB tube. Incubate the TSB tube at 37°C for 15-18 h.
- b) Liquefy 1% TSA and temper in a 45°C water bath. Prepare basal 1.5% TSA plates. All dilutions need to be plated in duplicate, thus number of basal plates and 5ml 1% TSA are to be made in accordance.
- c) Serially dilute MS2/Q β coliphage suspension using sterile PBS up to 10⁻¹² dilutions. Transfer 1 ml each from 10⁻⁷ to 10⁻¹² dilutions in sterile tubes, add 0.1 ml of respective *E. coli* host to each tube, mix well. Transfer ~ 5 ml of melted 1% TSA in each tube, mix well manually or using vortex and pour on basal TSA plates, with rocking plates to spread inoculum evenly. Allow the 1% TSA to solidify, invert and incubate at 37 °C for 15-18 h.

- d) After incubation, plates containing 20 – 200 distinct plaque forming units (pfu) are enumerated using a Colony Counter or manually. The MS2/Q β coliphage suspension titer is calculated by multiplying the number of pfu obtained by the inverse of the dilution factor.

B-6.4 Preparation of Challenge water

To prepare challenge water, use appropriate quantities of the viral suspension (as prepared in C-6.2) to the defined volume of test water such that the final viral count is between 5×10^4 to 5×10^5 pfu/ ml. This is the input water, of which the count is verified and the same is used in calculating the log reduction.

B-7 ENUMERATION OF MS2/Qbeta COLIPHAGE PLAQUES IN INFLUENT AND EFFLUENT WATER SAMPLES FOR VIRUS REDUCTION

B-7.1 Serial dilutions of the influent and effluent water samples (10^{-1} to 10^{-5}) are made using sterile PBS. In sterile tubes, 1 ml of diluted MS2/Q β coliphage is transferred from each of the 10^{-1} to 10^{-5} dilutions tubes. Add 0.1 ml of respective *E. coli* host to ~ 5 ml to each of the phage tube, mix, add ~5ml of melted 1%TSA. Manually mix or Vortex the inoculum and media and pour on 1.5% TSA base plates with rocking to spread the inoculum evenly. After the TSA layer has solidified, the plates are inverted and incubated at 37°C for 15-18 h.

B-7.2 After incubation, plates containing 20 – 200 distinct plaque forming units (pfu) are enumerated manually or using a Colony Counter. The coliphage suspension titer is calculated by multiplying the number of pfu obtained by the inverse of the dilution factor. Results are expressed as the number of pfu/ml.

B-8 CHALLENGE VERIFICATION

After the appropriate incubation period, the coliphage plaques are counted on plates showing plaques between 20 & 200 and determine the mean number per milliliter by multiplying the dilution factor. This count verifies that the challenge organism was present in the test water at the optimum concentration before conducting the challenge reduction test.

B-9 METHOD OF CHALLENGING UV TEST SYSTEMS AND DETERMINING THE LOG REDUCTION

B-9.1 Install and condition the new UV systems (two) as per the manufacturer's instructions. Flush the system as per manufacture specifications with general test water.

Water flow/route pipes, pump and UV chamber (of the device) shall be shock disinfected with a strong oxidizing agent like chlorine and thereafter flushed clean with sterile water in order to completely eliminate the traces of any residual effect of the disinfectant.

B-9.2 Ageing

B-9.2.1 Since maximum drop in initial UV intensity occurs during the first 24 h period, therefore the device shall be kept 'ON' for minimum 24 h (that is the UV lamp should have been on for 24 h) prior to subjecting it to the challenge test.

B-9.2.2 Connect the system to the microbiological influent challenge water feed at the maximum recommended inlet pressure and allow at least 10 L of product water to filter and drain away with the product water storage tank tap open.

B-9.2.3 Then close the storage tank faucet and allow the tank to fill until automatic cut-off. Collect water samples from the influent challenge water tank and the product water storage tank in duplicate and analyze for the microbiological contaminants.

B-9.2.4 In case of direct flow models (where no storage tank is provided), allow 10 L of product water to flow before collecting samples.

B-9.3 Determination of log₁₀ Reduction

The Viral log reduction is calculated as follows:

$$\frac{\text{PFU/ml in input} - \text{PFU/ml in output}}{\text{PFU/ml in input}}$$

B-10 SAFETY PRECAUTIONS AND HAZARDS

- a) Steam sterilized samples and equipment shall be handled with protective gloves when being removed from the autoclave.
- b) Cryogenic culture vials shall be handled with cryoprotective gloves.
- c) All microbiological samples and contaminated test supplies shall be steam-sterilized to 120 °C at 15 psi (103421 Pa) for a minimum of 20 min prior to being discarded.

ANNEX C
(Clause 6)

SAMPLING PLAN FOR UV SYSTEM

C-1 Four sample units of UV purification devices are randomly selected from the same batch, having the same capacity, produced under similar condition of manufacturing shall constitute a batch. To ensure the randomness of selection, methods given in IS 4905 may be followed.

C-2 Testing shall be done with 2 sets of sample units in duplicate as follows:

1. Set 1 – To be used for testing of Electrical, Hydrostatic pressure and Pneumatic test.
2. Set 2 – To be used for testing Virus reduction test.

C-3 Allow at least 10 litres of product water to pass before initiating any test

C-4 Allow at least 10 litres of product water after every sequence to wash out the previous set of contaminants.

C-5 All water samples shall be collected in triplicates, although only two of which may be subjected to analysis, with the other being retained for verification if required.

<i>Sl. No.</i>	<i>Parameters</i>	<i>No. of Units Tested</i>	<i>Day 1</i>	<i>Day 2</i>	<i>Day 3</i>	<i>Day 4</i>	<i>Day 5</i>
(1)	(2)	(3)	(4)	(5)	(6)	(7)	(8)
i)	Electrical	2 (new)	√	X	X	X	X
ii)	Hydrostatic		√	X	X	X	X
iii)	Pneumatic		√	X	X	X	X
iv)	Microbiological parameters	2 (new)					
	1) MS2 Coliphage or Q beta		√	√	√	√	√