

1 SCOPE

This standard specifies material, performance, constructional and other requirements of burr mill (see Fig. 1 and Fig. 2). It also prescribes the methods for test to evaluate the performance of burr mills.

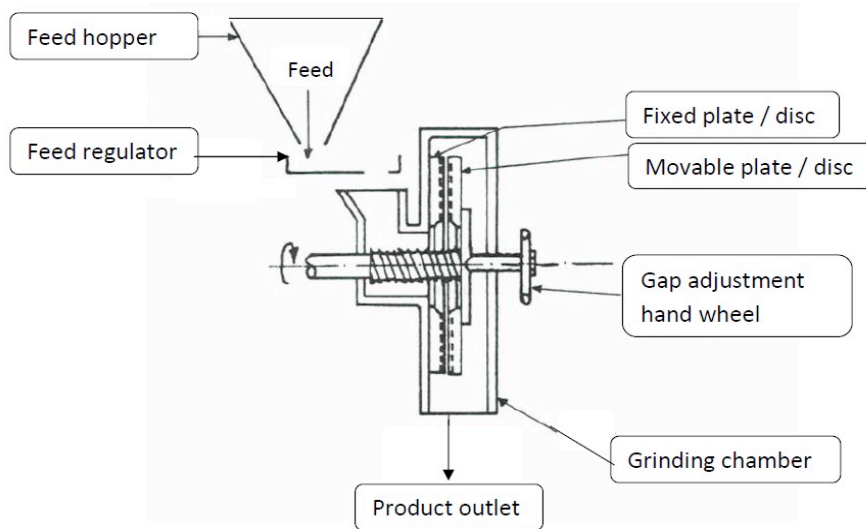

FIG. 1 SCHEMATICS OF VERTICLE TYPE BURR MILL

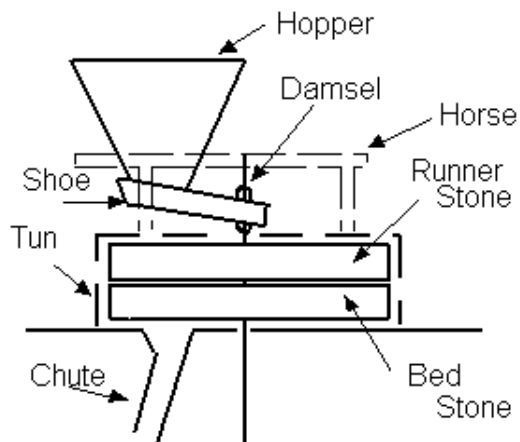

FIG. 2 SCHEMATICS OF HORIZONTAL TYPE BURR MILL

2 REFERENCES

The following standards contain provisions which through reference in this text, constitute provision of this standard. At the time of publication, the editions indicated were valid. All standards are subject to revision, and parties to agreements based on this standard are encouraged to investigate the possibility of applying the most recent editions of the standards indicated below:

<i>IS No.</i>	<i>Title</i>
IS 210: 2009	Grey iron castings — Specification (<i>fifth revision</i>)

IS 460 (Part 1): 2020	Test Sieves — Specification Part 1 Wire Cloth Test Sieves (<i>fourth revision</i>).
IS 816: 1969	Code of practice for use of metal arc welding for general construction in mild steel (<i>first revision</i>)
IS 2062: 2011	Hot rolled medium and high tensile structural steel — Specification (<i>seventh revision</i>)
IS 4333 (Part 2): 2017 / ISO 712: 2009	Methods of analysis for food grains: Part 2 Determination of moisture content (<i>second revision</i>)
IS 4454 (Part 4) : 2001	Steel wires for mechanical springs : Part 4 Stainless steel wire (<i>second revision</i>)
IS 6911 : 2017	Stainless steel plate, sheet and strip — Specification (<i>second revision</i>)
IS 9981: 2020	Agricultural produce processing equipment — Glossary of terms (<i>second revision</i>)
IS 10520 : 1989	Agricultural produce milling machinery — Emery stones for burr flour mills — Specification (<i>first revision</i>)

3 TERMINOLOGIES

For the purpose of this standard, the following definitions in addition to those given in IS 9981 shall apply.

3.1 Attrition — The action of undergoing compression and shear of the feed material between two flat abrasive surfaces. The equipment work on this principal is known as attrition mill.

3.2 Burr Mill — A type of size reduction equipment also known as plate mill and attrition mill as it works on the principles of attrition.

3.3 Capacity — The quantity of the grains ground into the product per unit time.

3.4 Clearance — The gap between the plates/stones/discs in an attrition mill.

3.5 Feed — The material fed for size reduction.

3.6 Feed Inlet — The hopper/delivery through which the feed material is let into the grinding/size reduction chamber for size reduction.

3.7 Grinding — A unit operation for size reduction of grains or its parts with some dissociation of the anatomical parts of the grain from one another.

3.8 Grinding Stone — A set of abrasive surfaces made of metal or emery to give attrition to the feed material when flown through the clearance.

3.9 Particle Size Distribution — The graphical relationship showing the fraction of each size of the separated materials in a sieve analysis with the average opening of sieve size. This is given on differential or cumulative basis.

3.10 Product — The material delivered after size reduction.

3.11 Product Outlet — The outlet from which the product after size reduction is delivered.

3.12 Sieve Analysis — Assessing the fraction of each size of the given material to the total quantity retained on each sieve when separated in a set of Taylor Series Sieves.

4 TYPES

4.1 Classification Based Laying of Grinding Surface

- a) Horizontal Type Burr Mill
- b) Vertical Type Burr Mill

4.2 Classification Based on the Number of Running Discs

- a) Single-runner Burr Mill
- b) Double-runner Burr Mill

5 MATERIALS

The material of construction of various components of the burr mill shall be as given in column 3 of Table 1. The material should conform to the relevant Indian Standards given in col 4 of Table 1. However, the use of stainless steel in place of cast iron or mild steel wherever found suitable is preferred.

Table 1 Material of Construction of Burr mill
(Clause 5.1)

Sl. No.	Component	Material/Grade of Material	Reference to Indian Standard
(1)	(2)	(3)	(4)
i.	Feed hopper	Stainless steel grade X04Cr19Ni9	IS 6911
ii.	Cam	High carbon steel	-
iii.	Cover of grinding chamber	Stainless steel grade X04Cr19Ni9	IS 6911
iv.	Product outlet	Stainless steel grade X04Cr19Ni9	IS 6911
v.	Eccentric	Cast iron	IS 210
vi.	Frame	Mild steel	IS 2062
		Cast iron	IS 210
vii.	Gears	High carbon steel	IS 7226
viii.	Hand wheels/adjustment levers	Cast iron	IS 210
		Mild steel	IS 2062
		Stainless steel grade X04Cr19Ni9	IS 6911
ix.	Pullies	Cast iron	IS 210
		Mild steel	IS 2062
x.	Shafts	Mild steel	IS 2062
xi.	Springs	Spring steel	IS 4454 (Part 4)
xii.	Vibrator (optional)	Electromagnetic	-

6 CONSTRUCTIONAL REQUIREMENTS

6.1 Clearance Adjustment — The clearance or gap between the discs shall be adjustable continuously in the range of 0 to 5 mm, by moving the discs, either the rotating or stationary disc using the hand wheel provided, according to size of product and locked at set position.

6.2 Frame — The main frame shall be fabricated using suitable size of mild steel with channel/angle sections or cast iron and shall be covered wherever required with mild steel sheet/galvanized sheet/stainless steel sheet of adequate thickness, not less than 0.70 mm, depending on the requirements.

6.3 Grinding Chamber — The grinding chamber shall house the grinding discs/plates and shall be provided with cover. The feed inlet and product outlet shall be placed on the chamber in such a way that there is no leakage. For cooling the chamber, the cover may be provided with a jacket for circulating cooling water or brine.

6.4 Grinding Disc — The emery type grinding disc/stone used in the burr mill shall confirm to IS 10520. The grinding disc/plates made of steel shall be reconditioned by re-forming the grooves. These discs or stones or plates shall be fixed firmly with a locking arrangement and shall be easily removed and fitted for maintenance/replacement.

6.5 Hopper — The hopper shall be made of metal sheet with minimum thickness of 1.0 mm. The hopper shall be provided with a feed regulating device with provision to deliver the feed into the grinding chamber. The hopper shall be placed at appropriate height for feeding manually or provided with a bucket elevator.

6.6 Power Transmission

6.6.1 Suitable system for transmitting the power shall be provided through belt system with provision to adjust the belt tension.

6.6.2 Transmission guards shall be provided to prevent accidental contact of persons or parts of clothing being caught in the transmission system, unless the system is so constructed or placed as to be safe without guards.

6.6.3 The guards shall be so designed as not to hinder in easy adjustment, servicing and operation of separator.

6.6.4 It is preferable that all guards shall be either permanently attached or firmly secured to prevent their removal without the aid of tools. The servicing and adjustments should be possible without complete removal of the guards.

6.6.5 The guards shall have sufficient strength to support load of 600 N applied at any point over an area of 0.1 m² without permanent set.

NOTE — Depending upon space available, the area and load may be correspondingly increased or decreased for testing purposes.

6.6.6 The axle shaft shall be finished and within tolerance band of the bearings and shall be properly aligned.

6.6.7 Provision shall be made for lubrication of bearings, and these shall be dust proof.

6.7 Workmanship and Finish

6.7.1 The components of the burr mill shall be free from cracks, pits, holes and other visual defects which may be detrimental for their use.

6.7.2 The welding, if done, shall not be porous and shall be smooth (*see* IS 816).

6.7.3 A rust preventive coating shall be provided to the steel components and a preventive coating for the wooden components.

7 PERFORMANCE REQUIREMENTS

7.1 The burr mill shall be operated at no load in accordance with **9.4.2**. During the no load run, the visual observation shall not show the following abnormalities:

- a) Presence of any marked vibrations during operation;
- b) Presence of undue knocking or rattling sound;
- c) Frequent slippage of belts/chains;
- d) Non-smooth running of shafts in the bearing housings;
- e) Any marked wear or slackness in any components;
- f) Any marked rise in temperature of operational bearings and its housing;
- g) No mechanical damage to any components of cleaner cum grader.

7.2 During and after the test at load (*see* **9.4.3** and **9.4.4**), the visual observation shall not indicate the following:

- a) Observations given under **7.1 (a) to (g)**;
- b) Frequent clogging of screen perforations;
- c) Non-smooth flowing of material through different components;
- d) Frequent clogging of aspiration unit;
- e) Any marked wear, deformation and breakdown;
- f) Frequent loosening of fasteners; and
- g) Leakage of grains from the cleaner, while in operation.

7.3 When tested in accordance with **9.4.2**, **9.4.3** and **9.4.4**, no breakdown shall occur in any units of the burr mill.

7.4 The input capacity of the mill shall be not less than 10 kg/kWh. The capacity shall be declared by the manufacturer.

7.5 The noise level of the burr mill shall not exceed 75 dB(A) when tested as per **9.4.2.4**.

7.6 The rise in temperature between the feed and product shall not be more than 20°C when no cooling provision is there in the grinding chamber. If provided with cooling arrangements it shall be less than 10°C.

8 OTHER REQUIREMENTS

8.1 Various controls shall be accessible easily and capable of being locked at selected position and accessed by the operator.

8.2 Operation and maintenance manual along with safety instructions shall be supplied by the manufacturer.

8.3 Provision for changing/adjusting the feed rate shall be available.

8.4 The burr mill shall be suitable for grinding various grains, spices, and other dry materials, as required.

8.5 Magnets shall be provided to arrest iron contaminants flowing into grinding chamber to prevent damage to the grinding stones/plates.

8.6 There shall be a provision for easily clearing the jam of the feed material.

8.7 The grinding stones shall be easily removed for cleaning/washing.

9 TESTS

9.1 Test Material

9.1.1 Raw Material

The test material shall be cleaned seed or kernels. Wheat, sorghum, dehusked splits of chickpea and coriander shall be preferred. Also any material specific to the end user preferably of the same variety/type shall be taken for all the runs. The quantity shall be sufficient to work the burr mill for a period of 90 minutes after reaching the normal working condition. Also test materials shall be graded and free from foreign materials such as, chaff, stone, pieces of metal, mud and other crop grains.

9.1.2 Moisture Content

The material for test should have a moisture content of 8 to 10 percent (w.b.).

9.1.3 Average Size

The mean diameter of particles in the feed shall be determined by standard sieve analysis (*see 9.4.3.2*) and shall be reported in mm or in μm units. If the feed material is adequately large and uniform in size, the diameter will be measured using vernier caliper or screw gauge or any suitable measuring device with appropriate least count, taking 25 numbers of samples and reporting the mean.

9.2 Machinery Selection and Installation

9.2.1 The selection of burr mill for testing shall be done in accordance with the manufacturer.

9.2.2 The burr mill shall be installed on a level and preferably on a hard surface with anti-vibration mount/concrete foundation.

9.3 Running in and Preliminary Adjustments

9.3.1 After installation, all the adjustments in the burr mill shall be made in accordance with the recommendations of the manufacturer/supplier.

9.3.2 The burr mill shall be attached with a suitable prime mover preferably with an electric motor of capacity recommended by the manufacturer and auto voltage stabilizer. A suitable size wattmeter or energy meter shall be fitted. The power delivered to the burr mill may be supplied in the following ways:

- a) Direct coupling the prime mover with the main shaft of the burr mill, or
- b) Connecting the prime mover with the help of flat or V- belt and pulleys with the main shaft of the burr mill.

9.3.3 The burr mill shall be run-in without load before commencing of the tests. The running-in shall be carried out in accordance with the recommendations of the manufacturer/supplier. In the absence of the recommendations, the running-in shall be carried out for 30 min. During the period of run-in, adjustment for various functional components may be done. All the adjustments shall be done in accordance with the instructions manual supplied by the manufacturer/supplier.

9.4 Type Tests

9.4.1 General Tests

9.4.1.1 *Checking of specifications* — The specifications given by the manufacturer shall be checked and reported in the proforma as given in Annex A.

9.4.1.2 *Checking of material* — The material of construction of all the components of the burr mill shall be reported in the data sheet given in Annex B.

9.4.1.3 *Visual observations and checking of provision for adjustments* — The observations and adjustments given in data sheet in Annex C shall be made and reported.

9.4.2 Test at No-load

9.4.2.1 *Visual observations* — After the running-in is over, the burr mill shall be run at no load for 30 min at the specified speed. During and after the no-load run, the visual observation of the burr mill shall not show the failures as given in 7.1 and shall be reported in Annex C.

9.4.2.2 *Power consumption* — The average power required to run the burr mill at no load conditions will be reported in Annex D as observed from the wattmeter at 5 min. interval or from the energy meter observed for 5 min. at 10 min. interval.

NOTE — In case of energy meter if it is not possible to measure the reading in the specified time, the number of revolution of disc may be counted and converted into the number of units consumed.

9.4.2.3 *Speed of operation* — The speed of operation of the main shaft and the feed agitator (if any) shall be measured using a contact type/contact less tachometer and reported (rev/min.) with 5 rpm accuracy in Annex D.

9.4.2.4 Noise— The level of noise produced by the machine should preferably be recorded using a noise level meter and shall be reported in dB (A). The measurements should be done at radius of 2 m and 4 m from centre of the machine at 30 degrees interval radially in 5 min. time interval. The average noise level will be reported in dB (A) in Annex D.

9.4.3 Short Run Test

9.4.3.1 Operation and collection of data

The burr mill shall be operated at its specified speed and at appropriate clearance (between grinding surfaces) after achieving the normal steady state operation for 30 minutes at a feed rate slightly below 90 percent of its specified capacity. During the run period, collect the following samples and data in the format given in Annex E.

- a) Three sets of samples of the test material (feed/raw material) and flour (product) at an interval of 10 min each;
- b) The power requirement (*see* 9.4.2.2);
- c) The speed of-main shaft (*see* 9.4.2.3);
- d) Noise level (*see* 9.4.4.4); and
- e) Temperature of the feed, and the flour (product) using a suitable thermometer/temperature measuring device of 1°C, at an interval of 5 min each.

At the end of 30 minutes feeding, run the burr mill for some time (2 to 5 min.) so that practically no more material already fed comes out. In case the mill has a large casing, this should be opened to clear all the ground material resting inside. It should be weighed and recorded.

This test shall be repeated for minimum of two times at 100 and 110 percent of the capacity declared by the manufacturer.

9.4.3.2 Analysis of samples

Standard IS test sieves [*see* IS 460 (Part I)] shall be used for sample analysis and the particle size distribution be expressed in the following forms (*see* Annex E).

- i) Average particle size of product,
- ii) Fineness Modulus, and
- iii) Uniformity Index.

According to the particle size of the product the sieves shall be selected from the Taylor's Sieve Series in ISS No. Minimum of 100 g of product (flour) shall be taken for the sieve analysis. The set of sieves will be run for 10 minutes and the weight of product retained on each sieve. The data will be recorded in the format given in Annex F.

9.4.3.3 Specific energy consumption

Energy consumption for milling by the testing machine be specified in the form of specific energy for milling as follows:

$$S_p = \frac{[(P_{\text{load}} \times n_{\text{load}}) - (P_{\text{no load}} \times n_{\text{no load}})]}{\text{Weight of product milled}}$$

Q

where,

S_p = specific energy for milling, W h/kg;

P_{load} = Wattmeter reading (average) at load, W;

$P_{no\ load}$ = Wattmeter reading (average) at no load, W,

n_{load} = efficiency of prime mover at load (assume 0.90, if not specified);

$\eta_{no\ load}$ = efficiency of prime mover at no load (assume 0.50, if not specified); and

Q = throughout of the machine, kg/h

9.4.3.4 Rise in temperature of the product

The rise in the temperature of the product at an interval of 5 min from start till 30 minutes of operation shall be measured with thermometer and recorded. The temperature rise would be calculated as:

Temperature rise (°C) = [Temperature of flour (°C) – Temperature of feed (°C)]

Lesser the rise in temperature measured after 30 min of continuous operation shall be preferred.

9.4.3.5 Rated capacity

Select the feed rate (among 90, 100 and 110% of the specified capacity) at which specific energy for milling (*see 9.4.3.3*) of machine is minimum.

9.4.4 Long Run Test

The burr mill shall be operated for a minimum period of 24 hours at load. This period shall be covered in a maximum of 6 continuous runs of 4 hours each. During and after the operation, record of breakdowns, defects developed and repairing made shall be recorded in the format given in Annex G. The quality of the end product shall be analyzed.

10 SUMMARY REPORT

For the guidance of the user, a summary report shall be recorded in the proforma as given in Annex J.

11 MARKING AND PACKING

11.1 Marking

Each polisher shall be marked with the following particulars:

- a) Manufacturer's name and his recognized trade-mark, if any;
- b) Batch or code number;
- c) Power rating and capacity;

- d) Type;
- e) Model No.;
- f) Year of manufacturing; and
- g) Direction of rotating parts and rated speed.

A minimum cautionary notice worded as follows shall be written in vernacular language legibly and prominently on the main body of the polisher:

- a) Do not wear loose dress, bangles, watch, etc, while working;
- b) Do not work under the influence of intoxicants like liquor, opium, etc;
- c) Children and aged persons should be discouraged from working in burr mill;
- d) Do not cross over moving belts;
- e) Do not operate the burr mill without guards and safety devices;
- f) Do not make adjustment when burr mill is working; and
- g) Do not put or take-off belt while pulley is running.

11.2 Packing

The burr mill shall be packed as agreed to between the purchaser and the supplier for safe handling in transit.

11.3 BIS Certification Marking

The product(s) conforming to the requirements of this standard may be certified as per the conformity assessment schemes under the provisions of the Bureau of Indian Standards Act, 2016 and the Rules and Regulations framed there under, and the products may be marked with the Standard Mark.

ANNEX A *(Clause 9.4.1.1)*

SPECIFICATION SHEET

To Be Filled By

A-1 General

Manufacturer

Testing Station

- a) Make
- b) Model
- c) Serial number
- d) Year of manufacture
- e) Recommended seeds/kernels for grinding
- f) Rated capacity, kg/h
- g) Rated speed of operation, rev/min
- h) Suitability of crops or materials

2 Power Unit

- a) Type of prime mover
- b) Recommended power, kW
- c) Type of drive

3 Milling Chamber

- a) Diameter, mm
- b) Width, mm
- c) Speed of main shaft, rev./min.
- d) Provision for cooling the chamber

4 Hopper

- a) Capacity of hopper, kg or litres
- b) Position of hopper from ground, m
- c) Provision to control the feed rate
- d) Provision of elevator, if any

5 Milling Surfaces

- a) Material
- b) Diameter, mm
- c) Width, mm
- d) Type of grooves

6 Overall Dimensions

- a) Length, mm
- b) Width, mm
- c) Height, mm
- d) Total mass, kg

Testing Personnel

ANNEX B
(Clause 9.4.1.2)

DATA SHEET FOR MATERIAL OF CONSTRUCTION

Sl. No.	Component	Material	Confirming to IS
i.	Feed hopper		
ii.	Cam		
iii.	Cover of grinding chamber		
iv.	Discharge spout		
v.	Eccentric		
vi.	Frame		
vii.	Gears		
viii.	Hand wheels/adjustment levers		
ix.	Pullies		
x.	Shafts		
xi.	Springs		
xii.	Vibrator		
xiii.	Others, if any		

Testing Personnel

ANNEX C
(Clauses 9.4.1.3 and 9.4.2.1)

**DATA SHEET FOR VISUAL OBSERVATIONS AND PROVISIONS
FOR ADJUSTMENTS**

C-1 Observations:

- a) Adequacy of markings of direction of rotation
- b) Adequacy of protection of bearings against ingress of dust
- c) Adequacy of safety arrangements at moving parts
- d) Provision for lubrication of moving parts
- e) Provision for easy changing of components requiring replacements
- f) Tightness of belts, nuts/bolts, etc
- g) Adequacy of marking of inlet and outlets
- h) Provision for anti-corrosive coatings
- j) Welding of seams
- k) Other observations

C-2 Provisions for Adjustments of

- a) Feed-rate
- b) Speed of main shaft
- c) Clearance between grinding surfaces

Testing Personnel

ANNEX D
(Clauses 9.4.2.2, 9.4.2.3, and 9.4.2.4)

DATA SHEET FOR TEST AT NO-LOAD

D-1 Test Data

Sl. No.	Item	Readings						Avg.
		1	2	3	4	5	6	
1.	Speed of operation, rev/min							
2.	Power requirement (W)/Energy consumption (Wh)							
3.	Noise level, dB							

D-2 Observations

- a) Presence of any undue knocking or rattling sound
- b) Frequent slippage of belts/chains
- c) Smooth running of shafts in respective bearings
- d) Any marked rise in bearing temperature
- e) Presence of any marked vibration during the operation
- f) Any marked unusual wear or slackness in any component
- g) Any breakdown of major components
- h) Other observations.

Testing Personnel

ANNEX E
(Clause 9.4.3.1)

DATA SHEET FOR TEST AT LOAD

E-1 Source of Power

E-2 Power Rating, Kw

E-3 Type of Drive

E-4 Type and Variety of Feed Material

E-5 Moisture Content, % w.b.

E-6 Percentage of Foreign Matter in The Feed, %

E-7 Clearance Between The Plates/Discs, Mm

E-8 Maximum Input Capacity, kg/h

E-9 Test Data

S l. N o.	D a t e	S t a r t i n g t i m e	S t o p p i n g t i m e	D u r a t i o n o f o p e r a t i o n	S p e e d o f m a i n s h a f t (r p m)	F e e d r a t e (q / h)	P o w e r r e q u i r e d (k W)	C l e a r a n c e, m m	F u e l c o n s u m e d (1/ h)	N o i s e l e v e l d B (A)	T e m p e r a t u r e (° C)		N o. o f s a m p l e s	T o t a l q u a n t i t y o f f e e d d e l i v e r e d (q)	T o t a l q u a n t i t y o f p r o d u c t o b t a i n e d (q)
											F e e d	P r o d u c t			
(1)	(2)	(3)	(4)	(5)	(6)	(7)	(8)	(9)	(1 0)	(1 1)	(1 2)	(1 3)	(1 4)	(1 5)	(1 6)

E-10 Observation:

- a) Presence of any marked vibration during operation
- b) Presence of undue knocking or rattling sound
- c) Frequent slippage of belts

- d) Smooth running of shafts in their respective bearings
- e) Frequent clogging during grinding/size reduction
- f) Smooth flowing of material through different components
- g) Vibration free operation
- h) Any marked rise in bearing temperature
- j) Any marked wear, deformation and breakdown
- k) Frequent loosening of fasteners
- m) Other observations (if any)

Testing Personnel

ANNEX F
(Clause 9.4.3.2)

**DATA SHEET FOR ESTIMATION OF FINENESS MODULUS,
UNIFORMITY INDEX AND PARTICLE SIZE**

F-1 Data

Sl.No.	Indian Sieve No.	Clear opening, mm	Average particle size, mm	Weight of product retained, g	Percent material retained
--------	------------------	-------------------	---------------------------	-------------------------------	---------------------------

Pan

F-2 Determination of Fineness modulus

Fineness modulus of flour would be determined through analysis of the observations obtained through sieve analysis. Indian Standard Sieves No.: 100, 70, 50, 40, 30, 20 and 15 would be used. However the selection of the sieves will be based on the size of the product.

$$\text{Fineness modulus (FM)} = \frac{\text{sum of cumulative percent of material weight retained by the sieves}}{100}$$

F-2 Determination of Uniformity Index

Uniformity index shall be expressed in a ratio form specifically, the ratio of course : medium : fine particles in the product, where:

- a) Coarse aggregate — Rounded off weight of material retained by ISS 100, 70, and 50 mesh sieves
- b) Medium aggregate — Rounded off weight of material retained by ISS 40 and 30 mesh sieves
- c) Fine aggregate — The remaining part.

F-3 Determination of Average particle size

$$\text{Average particle size of product, mm} = 0.135 (1.366)^{\text{FM}}$$

Testing Personnel

ANNEX G
(Clause 9.4.4)

LONG RUN TEST DATA SHEET

- H-1** Total Running Time, h
- H-2** Continuous Running Time, h
- H-3** Breakdowns, if any
- H-4** Any Major Repairs Conducted
- H-5** Any Other Observation

Testing Personnel

ANNEX H
(Clause 10)

SUMMARY REPORT

J-1 Name of Manufacturer

J-2 Model Number

J-3 Name of Testing Station

J-4 Brief Description of The Burr Mill

J-5 Type and Variety of Feed Material Used

J-6 Percentage of Foreign Matter Present in The Feed

J-7 Moisture Content of Raw Material, % (w.b.)

J-8 Provisions for Adjustment of:

- a) Feed rate
- b) Speed of main shaft
- c) Clearance between the plates

J-9 Power Requirement, kW:

J-10 Recommended Power:

- a) Observed power at no-load
- b) Observed power at load at rated input capacity
- c) Observed power at maximum input capacity

J-11 Rated Input Capacity

J-12 Specific energy consumption, Wh/q

J-13 Any Marked Observation Affecting Performance

J-14 Any Marked Breakdowns

J-15 Other Observations

Testing Personnel

BUREAU OF INDIAN STANDARD**DRAFT FOR COMMENTS ONLY**

(Not to be reproduced without the permission of BIS or used as an Indian Standard)

भारतीय मानक मसौदा

कृषि उत्पाद मिलिंग मशीनरी — बर मिल —
विशिष्टि और परीक्षण संहिता
(आई एस 14442 का पहला पुनरीक्षण)

Draft Indian Standard

**AGRICULTURAL PRODUCE MILLING MACHINERY — BURR MILL —
SPECIFICATIONS AND TEST CODE**
(First Revision of IS 14442)

ICS 65.060

Agriculture and Food Processing Equipment Sectional Committee, FAD 20	Last date of comments: 24 June 2024
--------------------------------------------------------------------------	--------------------------------------------

FOREWORD

(Formal clause will be added later)

Milling of agriculture produce to grits and flours is an essential unit operation towards making them suitable for human consumption and for feed. One of the main equipment used in the process is burr mill.

This standard was originally published in 1997, to provide uniformity in reporting of test result of different burr mills and stipulated the methods of test of burr mill only. In this revision, the material, constructional, performance, and other requirements of burr mills in addition to the existing test methods have been incorporated apart from updation with respect to latest technological developments and best manufacturing practices.

For the purpose of deciding whether a particular requirement of this standard is complied with, the final value observed or calculated, expressing the result of a test or analysis, shall be rounded off in accordance with IS 2: 2022 'Rules for rounding off numerical values (*second revision*)'. The number of significant places retained in the rounded off value should be the same as that of the specified value in this standard.