

BUREAU OF INDIAN STANDARDS
DRAFT FOR COMMENTS ONLY

(Not to be reproduced without the permission of BIS or used as a standard)

Draft Indian Standard

Drums for Covered Winding Wires and Strips for Electrical Purposes — Specification

Winding Wires Sectional
Committee, ETD 33

Last date for comments- 5/12/2024

FOREWORD

Formal clause of the draft will be added later.

This standard was first published in 1962. First revision of this standard was undertaken in 1981 and second revision in 1991 to bring it in line with the practice followed and experience gained through its implementation.

The third revision has been undertaken in order to update mainly the dimensions of drums.

This standard is intended to cover the technical provisions relating to drums of covered winding wires and strips as supplied. It does not include the provisions of reeling and wrapping which shall be in accordance with the product specification.

Winding wires used in electrical equipment are typically packaged with a focus on protection and ease of use. Some of the common methods of packaging are drums, reels and spools. Reels are often made of wood, plastic, or metal and hold the wire in a neat coil. Reel sizes vary greatly depending on the wire's length and gauge. Flanges on the sides help prevent the wire from unwinding during transport. Spools are like reels, but generally smaller and with a cylindrical core. They're suitable for shorter lengths of wire and are often used for finer gauges. IS 14841/IEC 60264 series covers these packaging.

Drums are a popular choice for packaging winding wires, especially for larger gauges and longer lengths in India. Hence indigenous standardization is of immense value to the industry and users alike. It reduces wastage of raw material and avoids confusion. Drums can be made from wood or metallic materials. Earlier version had limited sizes and types. This version broadens the sizes, and types of materials.

For the purpose of deciding whether a particular requirement of this standard is complied with, the final value, observed or calculated, expressing the result of a test or analysis, shall be rounded off in accordance with IS 2: 2022 'Rules for rounding off numerical values (*second revision*)'. The number of significant places retained in the rounded off value should be the same as that of the specified value in this standard.

Draft Indian Standard

DRUMS FOR COVERED WINDING WIRES AND STRIPS FOR ELECTRICAL PURPOSES — SPECIFICATION

(Third Revision of IS 2089)

1 SCOPE

This standard specifies the dimensional requirements for drums for covered winding wires and strips for electrical purposes. It includes essential requirements for materials, construction and marking.

2 NOMENCLATURE

For the purpose of this standard the names of the various component parts of drums as shown in Fig.1 shall apply.

3 MATERIAL AND CONSTRUCTION

3.1 The drums shall be so constructed and made from such materials that they satisfy the conditions laid down in this standard. The flanges and barrel shall be free from protruding material capable of damaging the wire, strip or the hands of the operator during handling of the drum.

- a) For Plastic Spools: The material requirements are to be stated in purchaser's order.
- b) For Wooden Spools: The flanges shall be made of wood only.

3.2 All wooden components shall be manufactured from reasonably good quality soft wood or multiply strong plywood. The barrel may be made from thin plywood or veneer bent in a barrel form. The wood used in the construction shall be sound and free from defects that materially weaken the component parts of the drums. Wood preservative, which shall have no deleterious effect on the covering of the wire or strip, shall be used at the points where the barrel and flange components meet. If required by the purchaser the preservative treatment shall be applied to the entire drum.

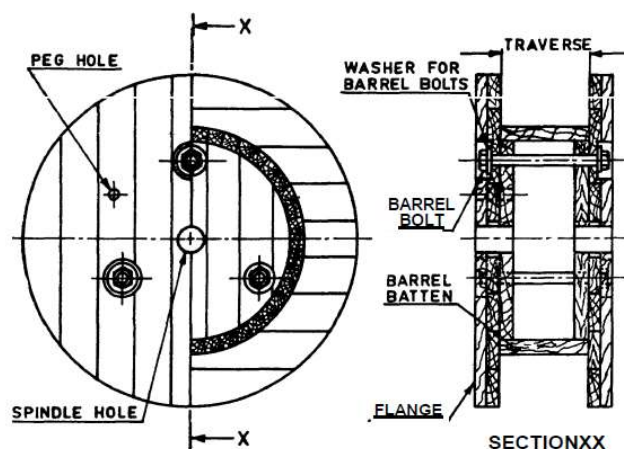

NOTE — The number of barrel bolts may be increased in case of larger drums.

FIG.1 DRUM NOMENCLATURE (DRUM SHOWN WITH WOODEN FLANGES)

3.2.1 For ply flanges, the barrel base shall be made of iron tubes and its ends shall be rivetted on the outside of the flanges and barrel shall be made by covering with tough flexible ply board or similar materials.

3.2.2 Other materials mentioned in Table 1 are also covered in the standard.

3.3 Flanges

3.3.1 Flanges, if made of plank, shall be constructed with two thicknesses of plank, at right angle to each other, nailed and clenched together. Nails shall be driven from the inside face of the flange, punched and then clenched on the outer face. Flange boards shall not be less than the nominal thickness by more than 2 mm. There shall be not less than two nails per board in each ring.

Thin veneer or plywood shall be glued with suitable waterproof adhesive on inside of the flanges, and between. The barrel, to protect the delicately covered material from the rough surface of the flange. Block wood construction for flange, that is, single layer of wooden planks sandwiched between two layers of plywood shall not be used for the construction of the flange.

3.3.1.1 All nuts, bolts, screws and other fasteners shall be flushed or countersunk below the surface of the flange except for ply flanges.

3.2.2 A suitable circular recessed space shall be provided on the flange for the label, if used, so that the label is below the flange surface and shall not be torn out in transit.

3.3.3 The flange shall be provided with a peg hole to take a braking device and for tensioning during unwinding. This shall be 16 mm in diameter and sufficiently deep and shall be drilled at a radius of 120 mm from the centre of the bore.

3.3.4 If required by the purchaser corrugated fasteners shall be applied at regular intervals on the circumference of the flange.

4 DIMENSIONS

The important dimensions of drums shall be in accordance with Table 1. Drum sizes shall be denoted by the reference numbers shown in Table 1.

5 MARKING

The flange of each drum may be marked with the reference number given in col 2 of Table 1.

Drums may also be marked with the Standard Mark.

Table 1 Dimensions of Drums
(Clauses 4.1, 4.2 and 5.1)

(All dimensions in millimetres.)

Sl No.	Ref No.	Flange Dia	Traverse	Barrel Dia	Flange Thickness, Max	Overall Width	Bore Dia	Capacity (Approz.) kg
(1)	(2)	(3)	(4)	(5)	(6)	(7)	(8)	(9)
i)	320(AL-P)	320±3.0	172±2.0	114±1.0	17.0±1.0	206±4.0	39±1.0	15
ii)	K355(CU-P)	353±3.0	156±2.0	200±3.0	17.0±1.0	190±4.0	22±1.0	15
iii)	D355(P)	355±3.0	160±2.0	224±2.0	28±1.0	216±4.0	40±1.0	40
iv)	400(P)	395±3.0	210±2.0	195±2.0	28±1.0	257±4.0	40±1.0	85
v)	400B(P)	395±3.0	230±2.0	250±3.0	28±1.0	257±4.0	40±1.0	70
vi)	400B(P)	395±3.0	230±2.0	300±3.0	28±1.0	257±4.0	40±1.0	35
vii)	450(P)	450±5.0	230±2.0	250±3.0	28±1.0	286±4.0	40±1.0	120
viii)	450(P)	450±5.0	230±2.0	300±3.0	28±1.0	286±4.0	40±1.0	85
ix)	D500(P)	500±5.0	230±2.0	250±3.0	28±1.0	286±4.0	40±1.0	180
x)	560M(P)	560±5.0	230±2.0	300±3.0	28±1.0	286±4.0	40±1.0	215
xi)	710(P)	710±5.0	230±2.0	250±1.0	28±1.0	286±4.0	40±1.0	475
xii)	710(P)	710±5.0	230±2.0	500±5.0	28±1.0	286±4.0	40±1.0	235
xiii)	310(W)	310±3.0	150±2.0	150±1.0	16.0±1.0	182±4.0	39±1.0	35
xiv)	350(W)	350±3.0	195±2.0	200±2.0	17.0±1.0	229±4.0	39±1.0	55
xv)	355(W)	355±5.0	200±2.0	300±3.0	28.0±1.0	256±4.0	40±1.0	50
xvi)	400(W)	402±5.0	145±2.0	200±2.0	17.0±1.0	179±4.0	39±1.0	80
xvii)	450(W)	438±5.0	195±2.0	278±3.0	17.0±1.0	229±4.0	39±1.0	80
xviii)	450(AL-W)	438±5.0	238±3.0	189±2.0	17.0±1.0	272±5.0	39±1.0	40
xix)	452(W)	450±5.0	200±3.0	300±3.0	28.0±1.0	256±4.0	39±1.0	80
xx)	482(W)	482±5.0	200±3.0	325±5.0	28.0±1.0	256±4.0	39±1.0	90
xxi)	500(AL-W)	500±5.0	235±3.0	200±2.0	19.0±1.0	273±5.0	39±1.0	65
xxii)	500(W)	495±5.0	235±3.0	199±2.0	19.0±1.0	273±5.0	39±1.0	180
xxiii)	500(W)	500±5.0	220±2.0	325±5.0	28.0±1.0	276±4.0	39±1.0	90
xxiv)	560(W)	560±5.0	235±3.0	245±3.0	19.0±1.0	273±5.0	39±1.0	90
xxv)	560(W)	560±5.0	235±3.0	245±3.0	19.0±1.0	273±5.0	39±1.0	100
xxvi)	560(W)	560±5.0	220±3.0	400±5.0	28.0±1.0	276±4.0	39±1.0	100
xxvii)	605(W)	605±5.0	220±3.0	455±5.0	28.0±1.0	276±4.0	39±1.0	110
xxviii)	610(W)	610±5.0	235±3.0	245±3.0	19.0±1.0	273±5.0	39±1.0	110
xxix)	630(W)	633±5.0	280±3.0	300±3.0	19.0±1.0	318±5.0	39±1.0	130
xxx)	635(W)	635±5.0	280±3.0	300±3.0	19.0±1.0	318±5.0	39±1.0	130
xxxi)	710(W)	710±5.0	240±3.0	460±5.0	38.0±1.0	376±4.0	40±1.0	250
xxxii)	900(W)	900±5.0	300±3.0	560±5.0	38.0±1.0	376±4.0	40±1.0	400
xxxiii)	1000(W)	1000±5.0	300±3.0	660±5.0	38.0±1.0	376±4.0	40±1.0	500

Note: AL-Aluminium W- wooden D- DIN P- Plastic CU-Copper AL-Aluminium W- wooden

