

**BUREAU OF INDIAN STANDARDS**  
**DRAFT FOR COMMENTS ONLY**

*(Not to be reproduced without the permission of BIS or used as a standard)*

---

*Draft Indian Standard*

**Self-Ballasted LED Lamps for General Lighting Services**  
**Part 1 Safety Requirements**

*First Revision of IS 16102 (Part 1)*

---

Lamps and Related Equipments  
Sectional Committee, ETD-23

Last date of comments: 09/02/2025

---

FOREWORD

(Formal clauses of the draft will be added later)

This draft Indian Standard (Part 1) (first revision) will be adopted by the Bureau of Indian Standards, after the draft finalized by the Lamps and Related Equipment Sectional Committee had been approved by the Electrotechnical Division Council.

This standard specifies the general and safety requirements for self-ballasted lamps for general lighting services for supply voltage range from  $> 50$  V ac up to 250 V ac at 50 Hz and a d.c. voltage up to 1000V. A proposal for a safety standard for LED lamps with voltages  $\leq 50$  V may follow in due course of time.

This standard was first published in 2012. The first revision has been undertaken to bring it in line with the latest IEC.

The significant technical changes with respect to the previous editions are as follows:

- a) Rated input power of lamps has been covered up to 60 W;
- b) Test requirements for photobiological safety have been added;
- c) LED lamps with rechargeable batteries have been covered;
- d) LED lamps with communication technology have been covered;
- e) Test requirements for abnormal operating conditions have been added;
- f) Test requirements for ingress protection have been added; and
- g) Sampling and passing criteria had been modified.

This standard is published in two parts. The other part in this series is:

## Part 2 Performance Requirements

This standard is based on IEC 62560: 2015 (Edition 1.1) ‘Self-ballasted LED-lamps for general lighting services by voltage > 50 V – Safety Specifications’, issued by the International Electrotechnical Commission (IEC).

For the purpose of deciding whether a particular requirement of this standard is complied with, the final value, observed or calculated expressing the result of a test or analysis, shall be rounded off in accordance with IS 2: 2022 ‘Rules for rounding off numerical values (*second revision*)’. The number of significant places retained in the rounded off value should be the same as that of the specified value in this standard.

*Draft Indian Standard*

**SELF-BALLASTED LED LAMPS FOR GENERAL LIGHTING SERVICES  
PART 1 SAFETY REQUIREMENTS**

*(First Revision)*

## **1 SCOPE**

This draft standard (Part 1) (First Revision) specifies the safety and interchangeability requirements, together with the test methods and conditions required to show compliance of LED-lamps with integrated means for stable operation (self-ballasted LED-lamps), intended for domestic and similar general lighting purposes, having:

- a) a rated power up to 60 W;
- b) a rated voltage above 50 V ac up to and including 250 V ac at 50 Hz and a d.c. voltage up to 1 000 V; and
- c) edison screw caps E14, E27 and Bayonet caps B22d and B15d.

Recommendations for whole product testing or batch testing are identical to those given in Annex C of IS 16103 (Part 1).

### NOTES

1. Where in this standard the term “lamp(s)” is used, it is understood to stand for “self-ballasted LED-lamp(s)”, except where it is obviously assigned to other types of lamps.
2. This standard includes photobiological safety.
3. This standard also includes lamp(s) incorporated with rechargeable batteries (replaceable and non-replaceable). Refer Annex A.
4. This standard applies also to lamps which incorporate additional functions, like but not limited to: communication technologies and/or sensors, and/or speakers, and/or energy storage (battery charging)

## **2 REFERENCES**

The standards listed below contain provisions which, through reference in this text, constitute provisions of this standard. At the time of publication, the editions indicated were valid. All standards are subject to revision, and parties to agreements based on this standard are encouraged to investigate the possibility of applying the most recent editions of the standards listed below:

<i>IS/IEC/ISO Number</i>	<i>Title</i>
IS 8913: 1978	Method of Measurement of Lamp Cap Temperature Rise
IS 9206: 1979	Dimensions of Caps for Tungsten Filament General Service Electric Lamps
IS 10322 (Part 1): 2014	Luminaires: Part 1 General Requirements and Tests (First Revision)
IS 1401: 2008	Protection Of Persons and Equipment by Enclosures - Probes for Verification (Second Revision)
IS 15518 (Part 1): 2004	Safety Requirements for Incandescent Lamps: Part 1 Tungsten Filament Lamps for Domestic and Similar General Lighting Purposes
IS 15885 (Part 1): 2011	Safety of Lamp Controlgear: Part 1 General Requirements
IS 16102 (Part 1): 2012	Self - Ballasted Led Lamps for General Lighting Services: Part 1 Safety Requirements
IS 16108: 2012	Photobiological Safety of Lamps and Lamp Systems
IS 16661: 2019	Application of IS 16108/IEC 62471 for the Assessment of Blue Light Hazard to Light Sources And Luminaires
IS/IEC 60529: 2001	Degrees Of Protection Provided by Enclosures (IP Code)
IS/IEC 60695-2-10: 2021	Fire Hazard Testing Part 2: Glowing Hot-Wire Based Test Methods Section 10: Glow-Wire Apparatus and Common Test Procedure
IS/IEC 60695-2-11: 2021	Fire Hazard Testing Part 2: Glowing Hot-Wire Based Test Methods Section 11: Glow-Wire Flammability Test Method for End Products GWEPT
IS/IEC 60695-2-12: 2021	Fire Hazard Testing Part 2: Glowing Hot-Wire Based Test Methods Section 12: Glow-Wire Flammability Index GWFI Test Method for Materials
IS/IEC 60695-2-13: 2021	Fire Hazard Testing Part 2 Glowing Hot Wire Based Test Methods Section 13 Glow-Wire Ignition Temperature GWIT Test Method for Materials

IEC 60061-3	Lamp Caps and Holders Together with Gauges for the Control of Interchangeability and Safety – Part 3: Gauge
IEC 61347-1:2015/AMD1:2017	Lamp Controlgear - Part 1: General and Safety Requirements
ISO 4046-4:2016	Paper, board, pulp and related terms – Vocabulary – Part 4: Paper and board grades and converted products

### 3 TERMINOLOGY

For the purposes of this standard, the terms and definitions of IS 16101, IS 16103 (Part 1) and the following shall apply:

**3.1 Self-Ballasted LED-Lamp** — Unit which cannot be dismantled without being permanently damaged, provided with a lamp cap and incorporating a LED light source and any additional elements necessary for stable operation of the light source.

NOTE — Lamp caps are given in IS 9206.

**3.2 Rated Voltage** — Voltage or voltage range marked on the lamp.

**3.3 Rated Wattage** — Wattage marked on the lamp.

**3.4 Rated Frequency** — Frequency marked on the lamp.

**3.5 Cap Temperature Rise ( $\Delta t_s$ )** — Surface temperature rise (above ambient) of a standard test lampholder fitted to the lamp, when measured in accordance with the standard method, in case of an Edison screw cap or a bayonet cap.

NOTE — The standard method of lamp temperature rise of Edison screw cap or bayonet cap is that given in IS 8913.

**3.6 Live Part** — Conductive part which may cause an electric shock in normal use.

**3.7 Type** — Lamps that have an identical electrical rating and a similar cap.

**3.8 Type Test** — Test or series of tests made on a type test sample for the purpose of checking compliance of the design of a given product with the requirements of the relevant standard.

**3.9 Type Test Sample** — Sample consisting of one or more similar units submitted by the manufacturer or responsible vendor for the purpose of the type test.

**3.10 Acceptance Test** — Tests carried out on samples taken from a lot for the acceptance of the lot.

**3.11 Batch** — All the lamps of one type put forward at one time for acceptance test.

**3.12 Ultraviolet Hazard Efficacy of Luminous Radiation ( $K_{S,v}$ )**— Quotient of an ultraviolet hazard quantity to the corresponding photometric quantity.

#### NOTES

1. Ultraviolet hazard efficacy of luminous radiation is expressed in mW/klm.
2. The ultraviolet hazard efficacy of luminous radiation is obtained by weighting the spectral power distribution of the lamp with the UV hazard function  $S_{UV}(\lambda)$ . Information about the relevant UV hazard function is given in IS 16108. It only relates to possible hazards regarding UV exposure of human beings. It does not deal with the possible influence of optical radiation on materials, such as mechanical damage or discoloration.

## 4 GENERAL REQUIREMENTS AND GENERAL TEST REQUIREMENTS

**4.1** The lamps shall be so designed and constructed that in normal use they function reliably and cause no danger to the user or surroundings.

In general, compliance is checked by carrying out all the tests specified.

**4.2** Self-ballasted LED-lamps are non-repairable, factory-sealed units. They shall normally not be opened for any tests. In the case of doubt based on the inspection of the lamp and the examination of the circuit diagram, and in agreement with the manufacturer or responsible vendor, either the output terminals shall be short-circuited or, in agreement with the manufacturer, lamps specially prepared so that a fault condition can be simulated shall be submitted for testing (*see 13*).

**4.3** In general, all tests are carried out on each type of lamp or, where a range of similar lamps is involved, for each wattage in the range or on a representative selection from the range, as agreed with the manufacturer.

**4.4** When the lamp fails safely during one of the tests, it is replaced, provided that no fire, smoke or flammable gas is produced. Further requirements on failing safe are given in **12**.

## 5 MARKING

**5.1** Lamps shall be clearly and durably marked with the following mandatory markings:

- a) Mark of origin (this may take the form of a trademark, the manufacturer's name or the name of the responsible vendor);

- b) Rated voltage or voltage range (marked 'V' or 'volts');
- c) Rated wattage (marked 'W' or 'watts');
- d) Rated frequency (marked in 'Hz');
- e) Rated lumen; and
- f) Country of manufacture.

**5.2** In addition, the following information shall be given by the lamp manufacturer on the lamp or immediate lamp wrapping or container or in installation instructions:

- a) Burning position, if restricted, shall be marked with the appropriate symbol. Symbol examples are shown in Annex B;
- b) Rated current (marked 'A' or 'ampere');
- c) For lamps with a weight significantly higher than that of the lamps for which they are a replacement, attention should be drawn to the fact that the increased weight may reduce the mechanical stability of certain luminaires and lamp-holders and may impair contact making and lamp retention.”;
- d) Special conditions or restrictions which shall be observed for lamp operation, for example operation in dimming circuits. Where lamps are not suitable for dimming, the following symbol in Fig. 1 may be used:



**Fig. 1 Dimming Not Allowed**

- e) Lamps with bulbs not suitable for water contact shall be marked with the symbol according to Fig. 2. The marking shall be provided on the packaging or accompanying information. The height of the graphical symbol shall be at least 5 mm. The symbol is not needed if a written cautionary notice is provided such as 'Use in Dry Locations only'; and



**Fig. 2 Lamp Not Suitable for Use under Moisture**

- f) Photo biological safety marking if applicable as per IS 16661.

**5.3** Compliance is checked by the following:

Presence and legibility of the marking required in **5.1** – by visual inspection.

The durability of the marking is checked by trying to remove it by rubbing lightly for 15 s with a piece of cloth soaked with water and, after drying, for a further 15 s with a piece of cloth soaked with hexane. The marking shall be legible after the test.

Availability of information required in **5.2** – by visual inspection.

**5.4 BIS Certification Marking**

The LED lamp(s) conforming to the requirements of this standard may be certified as per the conformity assessment schemes under the provisions of the *Bureau of Indian Standards Act, 2016* and the Rules and Regulations framed thereunder, and the LED lamp(s) may be marked with the Standard Mark.

**6 INTERCHANGEABILITY**

**6.1 Cap Interchangeability**

Interchangeability shall be ensured by the use of caps in accordance with IS 9206 and gauges in accordance with IS 9206, *see* Table 1.

Compliance is checked by the use of the relevant gauges.

**Table 1 Interchangeability Gauges and Lamp Cap Dimensions**  
(Clauses 1 and 6.1)

Sl. No.	Lamp Cap	Cap Sheet No. From IS 9206	Cap Dimensions To Be Checked By The Gauge	Gauge Sheet No. From IS 9206
(1)	(2)	(3)	(4)	(5)
i)	B15d	7004-11	<i>A Max</i> and <i>A Min</i> <i>D1 Max</i> <i>N Min</i>	} 7006-10 and 7006-11
ii)	B22d	7004-10	Diametrical position of the pins Insertion in lampholder Retention in lampholder	7006-4A 7006-4B
iii)	E14	7004-23	<i>Max</i> dimensions of the screw thread <i>Min</i> major diameter of the screw thread	7006-27F 7006-28B



		Dimension S1	7006-27G
		Contact making	7006-54
iv) E27	7004-21	<i>Max</i> dimensions of the screw thread	7006-27B
		<i>Min</i> major diameter of the screw thread	7006-28A
		Dimension S1	7006-27C
		Contact making	7006-50

## 6.2 Bending Moment and Mass Imparted by the Lamp at the Lamp Holder

The value of the bending moment and mass, imparted by the lamp at the lampholder shall not exceed the value given in Table 2.

The bending moment shall be determined by measuring the weight of the lamp (*for example* by means of a balance) at the tip of the bulb of the horizontally held lamp and multiplying this force by the distance between the tip of the bulb and the pivot line. The pivot line shall lie at the bottom end of the cylindrical part (for Edison and bayonet caps) or at the end of the contact pins (for pin caps). It shall be supported by an upright held thin metal sheet or a similar means.

**Table 2 – Bending Moments and Masses**  
(*Clause 6.2*)

Sl. No.	Cap	Bending Moment (Nm)	Mass (Kg)
(1)	(2)	(3)	(4)
i)	B15d	1	a)
ii)	B22d	2	1
iii)	E14	1	a)
iv)	E27	2	1

<sup>a)</sup> under consideration

### NOTES

1. For lamps with caps different to those in Table 2, the effect of the bending moment should be regarded and limited. A measurement method for these lamps with these caps is under consideration.

2. It should be taken care that the luminaire surface where the lampholder is fixed to can withstand the bending moment. For the calculation of this bending moment, the length of the lampholder needs to be taken into account when measuring the overall length. This should be made sure for the elevated temperature during operation in order to check the possible softening of the surface material.
3. Requirement for lamps with additional mechanical fixation e.g. rim mounted lamps is under consideration.

## **7 PROTECTION AGAINST ACCIDENTAL CONTACT WITH LIVE PARTS**

The lamps shall be so constructed that, without any additional enclosure in the form of a luminaire, no internal metal parts, basic insulated external metal parts or live metal parts of the lamp cap or of the lamp itself are accessible when the lamp is installed in a lampholder according to the relevant lampholder data sheet given in IS 9206.

Compliance is checked by means of the test finger specified in Fig. 3, if necessary, with a force of 10 N.

Lamps with Edison screw caps shall be so designed that they comply with the requirements for inaccessibility of live parts for general lighting service (GLS) lamps.

Compliance is checked with the aid of a gauge in accordance with the IS 9206.

Lamps with B22 and B15 caps are subject to the same requirements as normal incandescent lamps with this cap.

External metal parts other than current-carrying metal parts of the cap shall not be or become live. For testing, any movable conductive material shall be placed in the most onerous position without using a tool.

Compliance is checked by means of the insulation resistance and electric strength test (*see 8*).

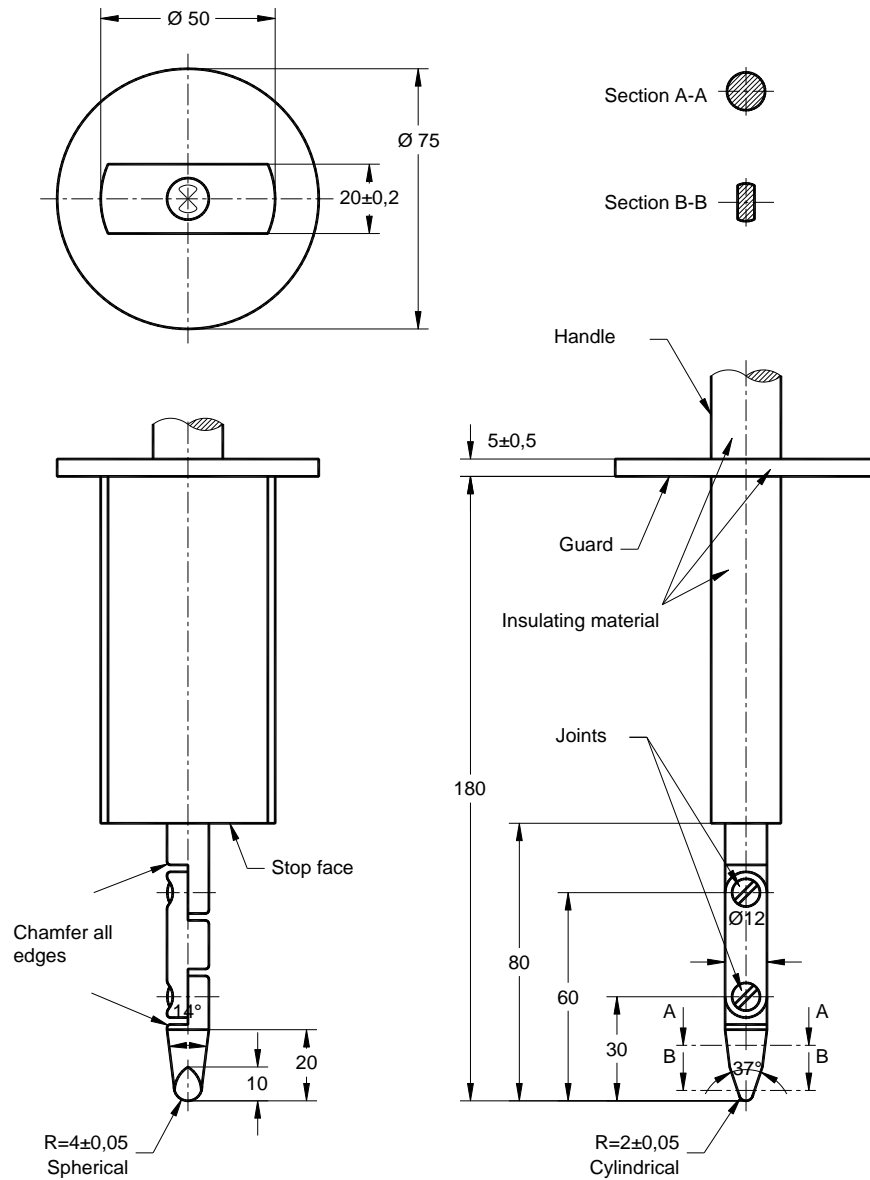

*Linear dimensions in millimetres*

Material: metal, except where otherwise specified

Tolerances on dimensions without specific tolerance:

- a) on angles:  $\begin{matrix} +0 \\ -10' \end{matrix}$
- b) on linear dimensions:
  - i) up to 25 mm:  $\begin{matrix} +0 \\ -0.05 \end{matrix}$
  - ii) over 25 mm :  $\pm 0.2$  mm

Both joints shall permit movement in the same plane and the same direction through an angle of  $90^\circ$  with a  $0^\circ$  to  $+10^\circ$  tolerance.

**Fig. 3 Standard Test Finger (According to IS/IEC 60529)**

## **8 INSULATION RESISTANCE AND ELECTRIC STRENGTH AFTER HUMIDITY TREATMENT**

### **8.1 General**

Insulation resistance and electric strength shall be adequate between live parts of the lamp and accessible parts of the lamp.

### **8.2 Insulation Resistance**

The lamp shall be conditioned for 48 h in a cabinet containing air with a relative humidity between 91 percent and 95 percent. The temperature of the air is maintained within 1 °C of any convenient value between 25 °C and 35 °C.

Insulation resistance shall be measured in the humidity cabinet with a d.c. voltage of approximately 500 V, 1 min after application of the voltage.

The insulation resistance between live parts of the cap and accessible parts of the lamp (accessible parts of insulating material are covered with metal foil) shall be not less than 4 MΩ.

NOTE — The insulation resistance of bayonet caps between shell and contacts is under consideration.

### **8.3 Electric Strength**

Immediately after the insulation resistance test, the same parts as specified above shall withstand a voltage test for 1 min with an ac. voltage or a d.c. voltage equal to the peak voltage of the prescribed ac. voltage as follows.

NOTE — The use of either ac. or dc. voltage is advised by the manufacturer.

During the test, the supply contacts of the cap are short-circuited. Accessible parts of insulating material of the lamp are covered with metal foil. Initially, no more than half the voltage as prescribed in Table 10.2 of IS 10322 (Part 1) for double and reinforced insulation is applied between the contacts and the metal foil. It is then gradually raised to the full value. Care shall be taken that the metal foil is so placed that no flashover occurs at the edges of the insulation.

No flashover or breakdown shall occur during the test. Measurements shall be carried out in the humidity cabinet.

## **9 MECHANICAL STRENGTH**

### **9.1 Requirements**

Lamps shall be able to withstand the relevant mechanical strength tests as given in **9.2**.

## 9.2 Tests

### 9.2.1 Torsion Resistance of Unused Lamps

In order to test the connection of the cap to the lamp shell the torsion resistance of unused lamps is tested as follows:

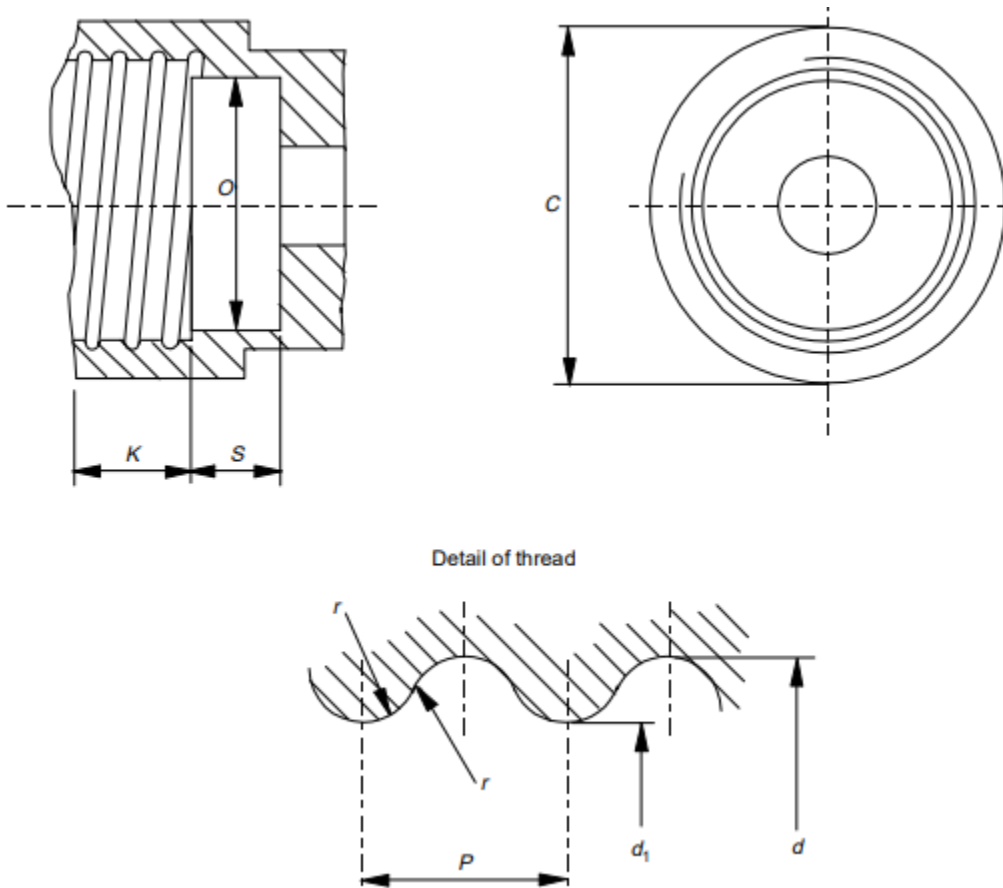

Surface finish of screw thread  $R_a = 0.4 \mu\text{m}$  Min (see note).

NOTE — A smoother surface might result in mechanical overloading of the cap - see also C-1.2 of IS 15518.

Dimensions in millimetres

Dimension	E14	E27	Tolerance
$C$	20.0	32.0	Min.
$K$	11.5	13.5	$0.0$ $-0.3$
$O$	12.0	23.0	$+0.1$ $-0.1$
$S$	7.0	12.0	Min.

$d$	13.89	26.45	$\begin{matrix} +0.1 \\ 0.0 \end{matrix}$
$d_1$	12.29	24.26	$\begin{matrix} +0.1 \\ 0.0 \end{matrix}$
$P$	2.822	3.629	—
$r$	0.822	1.025	—
NOTE — The drawing illustrates the essential dimensions of the holder which need only be checked if doubt arises from the application of the test.			

**Fig. 4 Holder for Torque Test on Lamps with Screw Caps**  
[from IS 15518 (Part 1)]

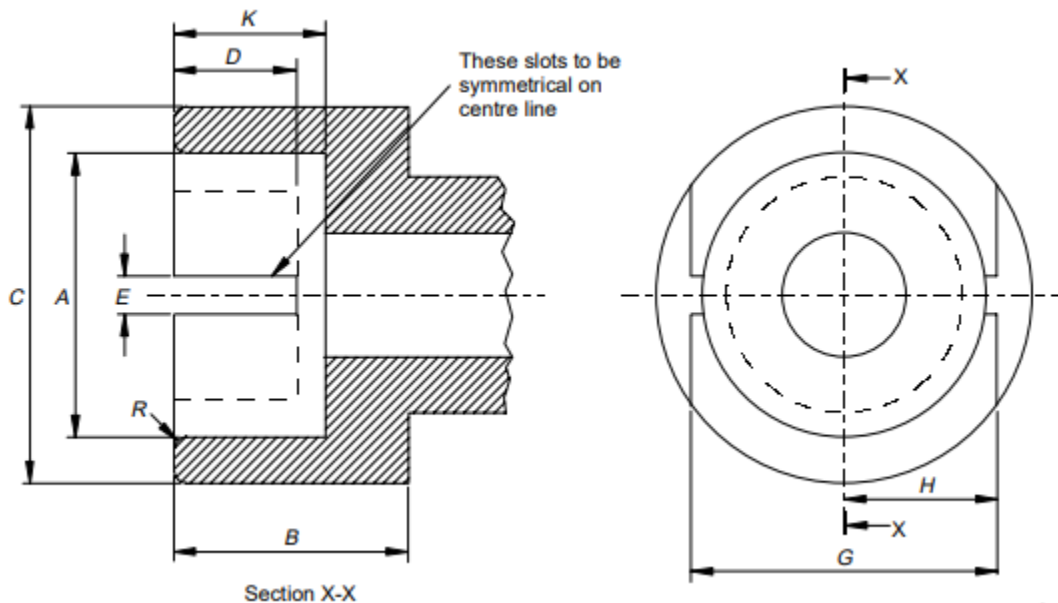

Dimension	B15 mm	B22 mm	Tolerance mm
$A$	15.27	22.27	+0.03
$B$	19.0	19.0	Min.
$C$	21.0	28.0	Min.
$D$	9.5	9.5	Min.

<i>E</i>	3.0	3.0	+0.17
<i>G</i>	18.3	24.6	±0.3
<i>H</i>	9.0	12.15	Min.
<i>K</i>	12.7	12.7	±0.3
<i>R</i>	1.5	1.5	Approximate
NOTE — The drawing illustrates the essential dimensions of the holder which need only be checked if doubt arises from the application of the test.			

**Fig. 5 Holder for Torque Test on Lamps with Bayonet Caps**  
(from IS 15518 (Part 1), Figure C.1)

**Table 3 – Torque Test Values for Unused Lamps**  
(Clause 9.2.1)

Sl. No	Cap	Torsion Moment (Nm)
(1)	(2)	(3)
i)	B15d	1.15
ii)	B22d	3
iii)	E14	1.15
iv)	E27	3

Before each use, the test holder for screw caps shall be checked to ensure that it is clean and completely free of lubricants and grease.

The cap of the test lamp shall be placed in the appropriate holder shown in Fig. 4 and 5. Either the cap or the part of the lamp which is used for inserting or removing the lamp may be mechanically clamped.

Torque shall be applied steadily to the appropriate lamp component, so that no jerk occurs. The application of the torque may follow either of the following schemes.

- a) The required torque shall be applied, according to the limits given in Table 3; and
- b) Higher torque values than the relevant limit shall be applied so that the value of torque for failure is obtained. In this case, the equipment is to be provided with suitable means for measuring torque over a wide range of failure levels.

*Compliance:*

The cap shall remain firmly attached to the bulb or that part of the lamp which is used for inserting or removing the lamp when subjected to the torque levels listed in Table 3.

Some lamps are made with parts designed to be moved after insertion (for example a light sensor or decorative ring). Movement of these parts does not constitute non-compliance.

In the case of un-cemented caps, relative movement between cap and bulb is permitted provided it does not exceed 10°.

### **9.2.2** *Torsion resistance of lamps after a defined time of usage*

The torsion resistance of used lamps is under consideration.

### **9.2.3** *Externally Applied Axial Pull and Bending Moment*

The lamp construction shall withstand externally applied axial pull and bending moment.

The bending shall be applied by holding in a uniform manner that part of the material closest to the cap. The pivot point lies at the cap reference plane (mating plane with the lamp holder). The pulling force and bending moment shall not be applied suddenly but shall be increased gradually from zero to the specified value.

Values are under consideration.

### *Compliance criteria:*

After the mechanical strength test of **9.2**, the sample shall comply with the requirements of **8**.

## **9.3 Axial Strength of Edison Caps**

The lamps shall be screwed into gauge of Table 4. After full insertion an axial force of Table 4 is applied to the central contact. *see* Fig. 6.

In case axial strength of the cap does not decrease when the unmounted cap was assembled to the finished lamp, test results on the unmounted cap can be applied.

NOTE — The gauges are used to hold the lamp. Calibration is not required.

### *Compliance:*

After this test the insulation around the central contact shall remain intact. The application of the torque test in **9.2.1** shall not lead to impressing the bottom part of the cap into the shell.



**Table 4 Values for Axial Force**

(Clause 9.3)

Sl. No	Cap	Gauge Sheet No. From IEC 60061-3	Axial Force (N)
(1)	(2)	(3)	(4)
i)	E14	7006-27F-1	80
ii)	E27	7006-27B-1	120

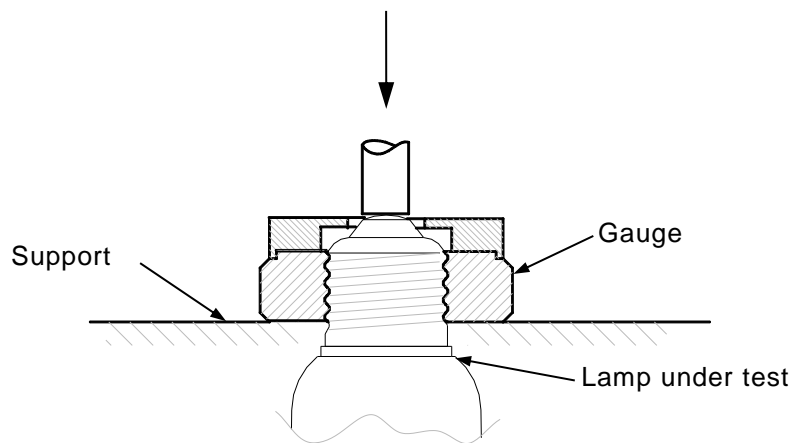

**Fig. 6 Test Equipment for Applying an Axial Force**

## 10 CAP TEMPERATURE RISE

The surface temperature rise (above ambient) of a lampholder fitted to the lamp shall not be higher than that of the lamp type which is being replaced by the lamp.

The cap temperature rise  $\Delta t_s$  of the complete lamp shall not exceed 120 K. The value of  $\Delta t_s$  corresponds to a incandescent lamp of 60 W *Max* The operating position and ambient temperature are detailed in IS 8913.

Measurement shall be carried out at rated voltage. If the lamp is marked with a voltage range, it shall be measured at the *Max* voltage of that range.

## 11 RESISTANCE TO HEAT

The lamp shall be sufficiently resistant to heat. External parts of insulating material providing protection against electric shock, and parts of insulating material retaining live parts in position shall be sufficiently resistant to heat.

Compliance is checked by subjecting the parts to a ball-pressure test by means of the apparatus shown in Fig. 7.

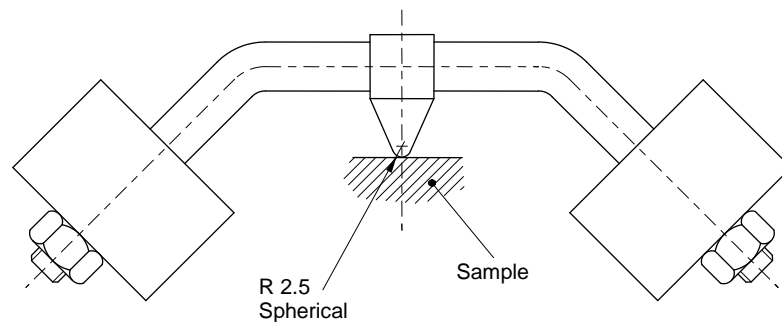

*Dimensions in millimetres*

**Fig. 7 Ball-Pressure Test Apparatus**

The test is made in a heating cabinet at a temperature of  $(25 \pm 5) ^\circ\text{C}$  in excess of the operating temperature of the relevant part according to Clause 10, with a *Min* of  $125 ^\circ\text{C}$  for parts retaining live parts in position and  $80^\circ\text{C}$  (value  $80^\circ\text{C}$  under consideration) for other parts. The surface of the part to be tested is placed in the horizontal position and a steel ball of 5 mm diameter pressed against this surface with a force of 20 N.

The test load and the supporting means are placed within the heating cabinet for a sufficient time to ensure that they have attained the stabilized testing temperature before the test commences.

The part to be tested is placed in the heating cabinet, for a period of 10 min, before the test load is applied.

The surface where the ball presses should not bend, if necessary the surface shall be supported. For this purpose, if the test cannot be made on the complete specimen, a suitable part may be cut from it.

The specimen shall be at least 2.5 mm thick, but if such a thickness is not available on the specimen, then two or more pieces are placed together.

After 1 hour the ball is removed from the specimen, which is then immersed for 10 s in cold water for cooling down to approximately room temperature. The diameter of the impression is measured, and shall not exceed 2 mm.

In the event of curved surfaces, the shorter axis is measured if the indent is elliptical.

In case of doubt, the depth of the impression is measured and the diameter calculated using the formula:

$$\phi = 2\sqrt{p(5 - p)}$$

in which  $p$  is the depth of impression.

The test is not made on parts of ceramic material.

## 12 RESISTANCE TO FLAME AND IGNITION

Parts of insulating material retaining live parts in position and external parts of insulating material providing protection against electric shock are subjected to the glow-wire test in accordance with IS/IEC 60695-2-10, IS/IEC 60695-2-11, IS/IEC 60695-2-12 and IS/IEC 60695-2-13, subject to the following details:

- a) The test specimen is a complete lamp. It may be necessary to take away parts of the lamp to perform the test, but care is taken to ensure that the test conditions are not significantly different from those occurring in normal use; and
- b) The test specimen is mounted on the carriage and pressed against the glow-wire tip with a force of 1 N, preferably 15 mm, or more, from the upper edge, into the centre of the surface to be tested. The penetration of the glow-wire into the specimen is mechanically limited to 7 mm.

If it is not possible to make the test on a specimen as described above because the specimen is too small, the above test is made on a separate specimen of the same material, 30 mm square and with a thickness equal to the smallest thickness of the specimen.

The temperature of the tip of the glow-wire is 650 °C. After 30 s, the specimen is withdrawn from contact with the glow-wire tip.

The glow-wire temperature and heating current are constant for 1 min prior to commencing the test. Care is taken to ensure that heat radiation does not influence the specimen during this period. The glow-wire tip temperature is measured by means of a sheathed fine-wire thermocouple constructed and calibrated as described in IS/IEC 60695-2-10.

Any flame or glowing of the specimen shall extinguish within 30 s of withdrawing the glow-wire, and any flaming drop shall not ignite a piece of the tissue paper, spread out horizontally  $200 \pm 5$  mm below the specimen. The tissue paper is specified in 4.187 of ISO 4046-4.

The test is not made on parts of ceramic material.

## 13 FAULT CONDITIONS

### 13.1 General Requirements

The lamps shall not impair safety when operated under fault conditions, which may occur during the intended use. The following fault conditions is applied in turn, as well as any other associated fault conditions that may arise from it as logical consequences.

### 13.2 Test Conditions

Only one component at a time is subjected to a fault condition.

Opening or bridging component in the circuit where the diagram or construction indicates that such a fault condition may impair safety.

Examination of the lamp and its circuit diagram will generally show the fault conditions which should be applied. These are applied in sequence in the order that is most convenient.

Components or devices in which a short-circuit does not occur shall not be bridged. Similarly, components or devices in which an open circuit cannot occur shall not be interrupted.

Manufacturers or responsible vendors shall produce evidence that the components behave in a way that does not impair safety, for instance, by showing compliance with the relevant specification.

Compliance is checked by operating the sample free burning, vertical cap up position at room temperature and at the most critical test voltage between 90 percent and 110 percent of the rated voltage.

In case a rated voltage range is declared, the test has to be carried out at the most critical test voltage between 90 percent and 110 percent of the mean voltage of that declared range or at the most critical test voltage within the declared voltage range, whatever range is greater.

In case of alternative rated voltage the test shall be performed separately for each rated voltage.

Example 1:

Declared voltage range: 220 V to 240 V: → Test voltage within 207 V to 253 V.

(90 percent to 110 percent of 230 V is wider than declared range)

Example 2:

Declared voltage range: 170 V to 280 V: → Test voltage within 170 V to 280 V.

(Declared range is wider than 90 percent to 110 percent of 225 V.)

*Compliance:*

Compliance is checked by operating the sample free burning at room temperature and at the most critical test voltage until stable conditions have been reached, then introducing the fault condition.

The sample is then tested for a further 8 h. During this test it shall not catch fire, or produce flammable gases and live parts shall not become accessible.

To check if accessible parts have become live, a test in accordance with clause 7 is made. The insulation resistance (*see 8.1*) is checked with a d.c. voltage of approximately 1 000 V.

#### **14 CREEPAGE DISTANCES AND CLEARANCES**

The requirements of IS 15885 (Part 1) apply except that for conductive accessible parts, relevant provisions of IS 10322 (Part 1) is applicable.

#### **15 ABNORMAL OPERATION**

Self-ballasted lamps shall not create hazard under abnormal operating conditions.

Self-ballasted lamps shall be constructed so that as a result of abnormal or careless operation, the risk of fire and mechanical damage impairing safety of protection against electric shock is obviated.

*Test procedure:*

Test non-dimmable lamp in test circuit shown in Fig. 8.

Determine R1 and S1 setting at which the  $Max I_{r.m.s.}$  occurs.

Test at this situation, and if the lamp passively fails within 60 min, repeat the test at 10 percent lower  $I_{r.m.s.}$ . The lower  $I_{r.m.s.}$  shall be set in the decreasing potentiometer resistance direction.

Repeat this procedure until stable operation is achieved for *Min* 60 min.

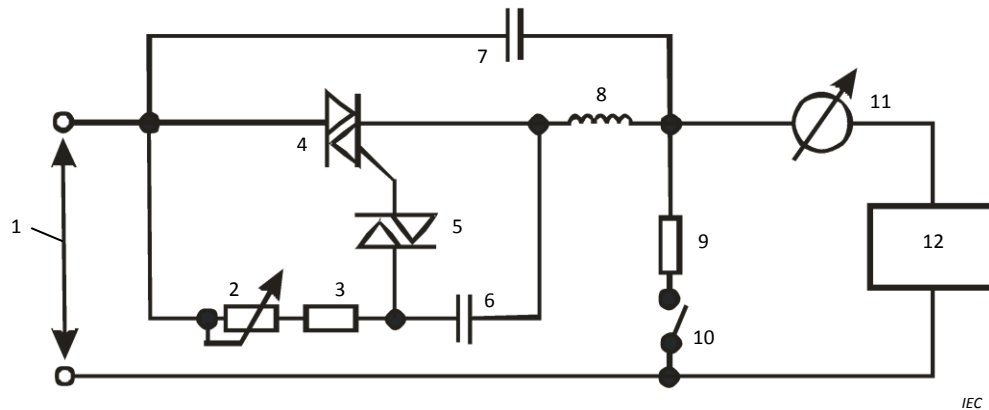

**Key**

- |                             |  |
|-----------------------------|--|
| 1 mains                     | 7 capacitor C2 = 68 nF to 150 nF         |
| 2 potentiometer R1 = 470 kΩ | 8 induction L1 = 3 mH                    |
| 3 resistor R = 3,3 kΩ       | 9 basic load, incandescent lamp P = 60 W |
| 4 Triac BTA16/700           | 10 switch S1                             |
| 5 Diac DB3                  | 11 $I_{r.m.s.}$ Ammeter                  |
| 6 capacitor C1 = 100 nF     | 12 device under test (DUT) (lamp)        |

NOTE — The most onerous situation for possible safety implication occurs at the  $Max I_{r.m.s.}$  that does not cause an immediate (passive) failure.

**Fig. 8 Test Circuit for Testing a Non-Dimmable Lamp at a Dimmer or Electronic Switch**

Operate the lamp for 8 h at the above most onerous dimming level (potentiometer adjustment).

*Compliance:*

Compliance is checked by operating the sample free burning, vertical cap up position or in the burning position indicated on the packaging at room temperature and at the rated voltage.

In case a voltage range is declared, the test has to be carried out at the mean voltage of that declared range.

In case of alternative rated voltages, the test shall be performed separately for each rated voltage.

During this test the lamp shall not catch fire, or produce flammable gases and live parts shall not become accessible with the standard test finger.

## 16 TEST CONDITIONS FOR DIMMABLE LAMPS

Test shall be carried out at *Max* power setting for Clause 10 and Clause 17. Test conditions for Clause 13 are under consideration.

## 17 PHOTOBIOLOGICAL SAFETY

### 17.1 UV Radiation

The ultraviolet hazard efficacy of luminous radiation of an LED lamp shall not exceed 2 mW/klm.

Compliance is checked by measurement of the spectral power distribution and subsequent calculation of the ultraviolet hazard efficacy of luminous radiation.

NOTE — LED lamps not relying on the conversion of UV radiation are not expected to exceed the *Max* allowed ultraviolet hazard efficacy of luminous radiation. They do not require measurement.

### 17.2 Blue Light Hazard

The blue light hazard shall be assessed according to IS 16661, which shall be regarded as normative when testing LED lamps to this standard. LED lamps shall be classified as risk group 0 unlimited or risk group 1 unlimited.

#### NOTES

1. LED lamps utilizing LED packages classified as RG0 unlimited or RG1 unlimited according to IEC 62471 are deemed compliant with the blue light hazard compliance criteria as per IEC TR 62778:2014 (IS 16661) and do not require further assessment or testing.

2. Clause C.2 of IS 16661 gives a method to classify lamps where full spectral data is not available.

### 17.3 Infrared Radiation

LED lamps are not expected to reach a level of infrared radiation where marking or other safety measurements are required.

## 18 INGRESS PROTECTION

### 18.1 Requirements

Lamps shall be suitable for water contact unless marked with Fig. 2.

## 18.2 Tests

Suitability for water contact is tested as follows.

The lamp is subjected to an IPX4 test according to the relevant provisions of IS 10322 (Part 1). During this test, lampholders sealing to the diameter of the lamp ends and providing protection to the contact area of IPX4 shall be fitted.

### NOTES

1. For more information about ingress protection (IP), *see* IS 10322 (Part 1), Annex J.
2. For higher IP rated lamps, testing shall be done as per the declared IP rating and marking shall be done accordingly.

A lamp constructed so that it is sealed (e.g. lamp designs having one piece homogeneous glass or plastic bulb penetrating the lamp holder sealing) to exclude water need not be subjected to this test.

## 19 INFORMATION FOR LUMINAIRE DESIGN

For information for luminaire design, Annex B applies.

## 20 SCHEDULE OF TESTS

### 20.1 Type Tests

The *Min* sampling size for type testing and the acceptance criteria shall be as given in Table 5. The sample shall be representative of a manufacturer's production:



**Table 5 Sample Sizes for Type Tests**  
(Clause 20.1)

Sl.No	Clause Or Sub- Clause	Test	Minimum Number of Units in a Sample	Maximum Number of Units That are Allowed to Fail
(1)	(2)	(3)	(4)	(5)
i)	<b>5</b>	Marking		
ii)	<b>6.1</b>	Cap Interchangeability		
iii)	<b>6.2</b>	Bending moment and mass imparted by the lamp at the lamp holder		
iv)	<b>7</b>	Protection against accidental contact with live parts		
v)	<b>8.2</b>	Insulation resistance		
vi)	<b>8.3</b>	Electric strength	5	0
vii)	<b>9.2.1</b>	Torsion resistance of unused lamps		
viii)	<b>9.2.2</b>	Torsion resistance of lamps after a defined time of usage		
ix)	<b>9.2.3</b>	Externally applied axial pull and bending moment		
x)	<b>9.3</b>	Axial strength of Edison caps		
xi)	<b>10</b>	Cap temperature rise		
xii)	<b>11</b>	Resistance to heat		
xiii)	<b>12</b>	Resistance to flame and ignition	1	0
xiv)	<b>13</b>	Fault conditions	5	0
xv)	<b>14</b>	Creepage distances and clearances	1	0
xvi)	<b>15</b>	Abnormal operation#	—	—
xvii)	<b>17.1</b>	UV radiation#	—	—
xviii)	<b>17.2</b>	Blue light hazard#	—	—
xix)	<b>18</b>	Ingress protection#	—	—
		# under consideration		

## 20.2 Acceptance Tests

The *Min* sampling size for acceptance testing and the acceptance criteria shall be as given in Table 6:

**Table 6 Sample Sizes for Acceptance Tests**  
(*Clause 20.2*)

Sl No.	Clause or Sub-Clause	Test	Minimum Number of Units in a Sample	Maximum Number of Units That are Allowed to Fail
(1)	(2)	(3)	(4)	(5)
i)	<b>5</b>	Marking	5	0
ii)	<b>6.1</b>	Cap Interchangeability		
iii)	<b>6.2</b>	Bending moment and mass imparted by the lamp at the lamp holder		
iv)	<b>7</b>	Protection against accidental contact with live parts		
v)	<b>8.2</b>	Insulation resistance		
vi)	<b>8.3</b>	Electric strength		
vii)	<b>9.2.1</b>	Torsion resistance of unused lamps		
viii)	<b>9.2.2</b>	Torsion resistance of lamps after a defined time of usage		
ix)	<b>9.2.3</b>	Externally applied axial pull and bending moment		
x)	<b>9.3</b>	Axial strength of Edison caps		
xi)	<b>10</b>	Cap temperature rise	1	0
xii)	<b>11</b>	Resistance to heat		
xiii)	<b>12</b>	Resistance to flame and ignition		
xiv)	<b>13</b>	Fault conditions	5	0
xv)	<b>14</b>	Creepage distances and clearances	1	0
xvi)	<b>15</b>	Abnormal operation	—	—
xvii)	<b>17.1</b>	UV radiation	—	—

---

viii)	<b>17.2</b>	Blue light hazard	—	—
xix)	<b>18</b>	Ingress protection	—	—

---

### 20.3 Accidentally Broken Lamps

Lamps which are accidentally broken before any test is started shall be replaced to ensure that the required number of test lamps completes the test.

NOTE — In order to avoid delay, it is recommended that spare lamps be available through the tests.

## 21 TESTS

### 21.1 Classification of Tests

#### 21.1.1 *Type Tests*

The following shall constitute the type tests to be carried out on selected sample of self ballasted lamps, sample being drawn preferably from regular production lot:

- a) Marking (*see 5*);
- b) Interchangeability (*see 6*);
- c) Protection against accidental contact with live parts (*see 7*);
- d) Insulation resistance and electric strength after humidity treatment (*see 8*);
- e) Mechanical strength (*see 9*);
- f) Cap temperature rise (*see 10*);
- g) Resistance to heat (*see 11*);
- h) Resistance to flame and ignition (*see 12*);
- j) Fault conditions (*see 13*);
- k) Creepage distances and clearances (*see 14*);
- m) Abnormal operation (*see 15*);
- n) Photobiological Safety (*see 17*); and
- p) Ingress protection (*see 18*).

#### 21.1.2 *Acceptance Tests*

The following shall constitute as acceptance tests:

- a) Marking (*see 5*);
- b) Interchangeability (*see 6*);
- c) Protection against accidental contact with live parts (*see 7*);
- d) Insulation resistance and electric strength after humidity treatment (*see 8*);
- e) Mechanical strength (*see 9*);
- f) Cap temperature rise (*see 10*);
- g) Resistance to heat (*see 11*);
- h) Resistance to flame and ignition (*see 12*);

- j) Fault conditions (*see 13*);
- k) Creepage distances and clearances (*see 14*);
- m) Abnormal operation (*see 15*);
- n) Photobiological Safety (*see 17*); and
- p) Ingress protection (*see 18*).

**Annex A**  
**(Normative)**  
*(Clause 1)*

**Battery Operated Lamps**

**A.1 GENERAL**

This annex specifies requirements for lamps containing or operating from batteries which are non-replaceable. Lamps designed with replaceable or non-user replaceable battery are not allowed to be manufactured as the same contradicts with the definition of “Self-Ballasted LED lamp” as per **3.1**.

This annex is applicable to lamps using:

Non-replaceable batteries, rechargeable and non-rechargeable batteries.

**A.2 MARKING**

Lamps with non-replaceable battery

Lamps using non-replaceable battery shall carry the substance of the following sentence in the instructions:

"The battery of this Lamp is not replaceable; when the battery reaches its end of life the whole Lamp shall be taken out of service".

**A.3 CONSTRUCTION**

**A.3.1 General**

For battery-operated Lamps with non-replaceable batteries, it shall not be possible to replace and/or to give access to the battery without breaking the Lamp or its parts.

**A.3.2 Short Circuit Protection**

The battery-operated Lamp is tested with the battery connected, under the following fault conditions applied one at a time:

Charging terminals of the battery-operated Lamp that are simultaneously accessible with the test probe 13 of IS 1401 are short circuited so as to produce the most unfavorable result. This test should be done after BMS IC (Charging /discharging / over voltage protection /short circuit protection) circuit which is mounted on driver PCB.

The battery-operated Lamp is switched on and no additional mechanical load is applied. The tests are conducted until the test sample achieves a steady condition, including returning to room temperature or, until a time period of at least 3 h has elapsed. The resistance of the short circuit shall not exceed 10 mΩ.

During the tests, the appliance shall not emit flames, molten metal, or ignitable gas in hazardous amount. No explosion or ignition of the battery shall occur during or after the test. Venting of the cells is permitted provided that they have not vented by any means other than through their vents.

### **A. 3.3 Electrical Parameters of the Batteries Operation**

#### **A. 3.3.1 General Conditions for Testing Lithium-Ion Battery Charging**

Measurements of cell voltages during the tests of lithium-ion systems shall be made using a single pole resistive-capacitive low pass filter with a cut-off frequency of 5 KHz  $\pm$  500 Hz. If charging voltage limits have been exceeded, the peak value of the voltage measured after this network shall be used. The measurement shall have measurement tolerance within  $\pm$ 1 percent.

The location of thermocouples for lithium-ion cell temperature measurements shall be on the temperature.

Currents measured during battery charging shall be average currents with an averaging period of 1 s to 5 s.

When a battery comprising of a single cell is employed, instructions in this document referring to special preparations of a cell in a series configuration shall be ignored.

For battery designs where there is a series arrangement of parallel clusters of cells, the cluster shall be treated as a single cell for those tests that require altering the amount of charge on a for battery designs where there is a series arrangement of parallel clusters of cells, the cluster single cell prior to conducting the test.

This standard does not apply to Lamps that are intended to charge general purpose cells or batteries installed by the user.

#### **A. 3.3.2 Normal Charging of Lithium-Ion Systems**

Charging a lithium-ion battery under normal conditions shall not exceed the specified operating region for charging of the cell Compliance is checked by the following tests.

The battery is charged in accordance with the charging system instructions starting with a ambient temperature of (20  $\pm$ 5) °C and if the battery-operated Lamp is recommended to be charged at a *Min* temperature lower than 4 °C, the test is also conducted at that *Min* temperature + 0 /-5 K;

If the battery-operated Lamp is recommended to be charged at a *Max* temperature greater than 40 °C, the test is also conducted at that *Max* temperature + 0 / +5 K

For all individual cells, the voltage, the temperature measured in accordance with A.3.3.1 and the charging current are monitored. In the case of parallel configurations, analysis may be used to avoid measuring the individual branch currents. The result shall not exceed their specified operating region for charging (e.g. limits of voltage and current dependent on the temperature).

NOTE — Following is an example result of such analysis: the charging current for each branch of a parallel connection would not need to be monitored, if the *Max* deliverable current of the charger did not exceed the *Max* charging current of a single cell.

For batteries employing series configurations, the test is repeated with a deliberately imbalanced battery. The imbalance is introduced into a discharged battery by charging one cell to approximately 50 percent of full charge

If it can be demonstrated through testing and/or design evaluation that an imbalance less than 50 percent would actually occur in normal use, then this lower imbalance may be used.

#### NOTES

1. Examples are those designs that employ circuitry intended for maintaining balance between cells in the battery pack. Systems with a small number of cells in series may be shown to exhibit limited imbalance in practice, if the product ceases to operate with a battery prepared with a smaller initial imbalance.
2. An example for a testing is repeated charging and discharging a battery in accordance with the manufacturer's instructions until its capacity has decreased to 80 percent of the rated capacity, using the imbalance at the end of the test.

### A. 3.4 Protection against Overpressure for Li-Ion Batteries Used in Lamps

The enclosure or compartment of a battery-operated Lamp that contains a battery that uses Li-ion chemistry with a single cell capacity of 0.2 Ah or greater, shall withstand the pressure generated when a cell vents during failure.

Compliance is checked by inspection and measurement in the case of a) or by the test of b).

- a) The total area of the unobstructed openings in the enclosure allowing gasses to pass shall be not less than the value specified in Table A.1; or
- b) A volume of air of the amount specified in Table A.2 shall be injected through a  $(2.85 \pm 0.05)$  mm diameter orifice into the enclosure at an initial overpressure of  $2\ 070\ \text{kPa} \pm 10$  percent. Test fittings used for the test shall not increase the enclosure volume by more than 3 ml. The overpressure within the enclosure shall drop below 70 kPa within 30 s without any unintended rupturing damage to the enclosure.

**Table A.1 Total Area of Openings for Li-ion Cells**

(Clause A.3.4)

Sl. No	Capacity of The Single Li-Ion Cell with The Highest Capacity (Ah)	Min. Total Area of Openings (mm <sup>2</sup> )
(1)	(2)	(3)
i)	$0.2 \leq Ah < 5$	20
ii)	$5 \leq Ah < 25$	30
iii)	$25 \leq Ah < 100$	50
iv)	$Ah \geq 100$	100

**Table A. 2 – Volume of Air Injected at 2 070 kPa**

(Clause A.3.4)

Sl. No	Capacity of The Single Li-Ion Cell with The Highest Capacity (Ah)	Volume of Air ( $\pm 10$ percent) (ml)
(1)	(2)	(3)
i)	$0.2 \leq Ah < 5$	20
ii)	$5 \leq Ah < 25$	30
iii)	$25 \leq Ah < 100$	50
iv)	$Ah \geq 100$	100

### A.3.5 Protection against the Consequence of Failure of Cells

Vents of cells shall not be obstructed in such a way as to defeat their operation if venting is relied upon for compliance with this standard.

Compliance is checked by inspection and by the tests of this standard.

### A.3.6 Thermal Test (Normal Operation)

For battery-operated Lamps, the temperature measured on surface of batteries shall not exceed the specified values.

During the charging mode, the surface temperatures have to be monitored starting from a discharged battery (level where the light source extinguishes), during the charging phase and where the battery is completely charged for a period suitable to reach steady state conditions unless otherwise specified below.



The following temperature limits are applicable unless otherwise specified by the battery manufacturer. The location of thermocouples cell temperature measurements shall be on the outer surface, half way along the longest dimension, of the cell that results in the highest temperature. It is important to determine the position of the *Max* surface temperature of the battery, particularly with respect to multi-cell battery packs.

Of the hottest point of the battery shall be detected. The temperature of the battery pack in the Lamp shall be assessed, whilst the Lamp is charging, to confirm the position of the hottest point on the battery pack. The hottest point of the battery pack when installed within a Lamp, when supplied as a control gear component, may be different to that already specified on the battery pack.

- a) For sealed nickel cadmium batteries, the *Max* surface temperature of the battery shall be:
  - i) 40 °C for designated T type cells;
  - ii) 50 °C for designated U type cells.

The *Max* surface temperature of the battery within the Lamp shall be measured after 48 h from start of recharge.

- b) For sealed nickel metal-hydride batteries, the *Max* surface temperature of the battery shall be:
  - i) 40 °C for designated T type cells;
  - ii) 50 °C for designated U type cells.

The *Max* surface temperature of the battery within the Lamp shall be measured after 48 h from start of recharge.

- c) For Li batteries, the temperature of the hottest point shall comply with the temperature limit as specified by the battery manufacturer.

The surface temperature of the battery is measured continuously from the start of charge for a period of 48 hours and at no time the temperature shall exceed limits.

### **A.3.7 Lithium-Ion Charging Systems – Fault Conditions**

This subclause applies only to Lamp using lithium-ion batteries.

The charging system and battery of a lithium-ion system shall be so designed that the risk of

- a) Fire and explosion as a result of fault condition during charging is obviated as far as is practical. Compliance is checked by the following test:
- b) A sample containing the battery and the associated assemblies of the charging system are placed on a soft wood surface covered by two layers of tissue paper (as defined in 4.187 of ISO 4046-4); the sample is covered by one layer of untreated 100 percent cotton medical gauze.

The Lamp is charged in accordance with the user instruction manual with all of the categories of fault conditions listed below in i) to iii).

- i) Electronic components in the charging system of the Lamp are subjected to the fault condition test according to clause 14 of IEC 61347-1:2015 + A1:2017, if the outcome of such a fault is uncertain based upon analysis. For each fault condition introduced, the state of the battery before charging is as follows:
  - A series configured battery shall have a deliberate imbalance. The imbalance is introduced into a discharged battery (level where the light source extinguishes) by charging one cell to approximately 50 percent of full charge; or
  - The test of **A.3.3.2** is conducted with an imbalance of less than 50 percent, a series configured battery shall have a deliberate imbalance as established in **A.3.3.2**; or
  - A single cell or parallel only configuration battery shall be discharged (level where the light source extinguishes).
- ii) If the test of **A.3.3.2** is conducted with an imbalance of less than 50 percent due to the function of circuit(s), and if a single fault of any component within that circuit(s) is shown to result in the loss of that function, then a series configured battery shall be charged with a deliberate imbalance. The imbalance is introduced into a discharged battery by charging one cell to approximately 50 percent of full charge.
- iii) For a battery with a series configuration, all cells are at approximately 50 percent charge, except for one which is shorted. The battery is then charged.

During the tests, each cell voltage is continuously monitored. Venting of the cells is permitted.

The ambient temperature or, if neither of these, until at least 7 h or twice the normal charge

Tests are considered passed if all of the following are true:

- a) There has been no explosion during the test.
- b) No charring or burning of the gauze or tissue paper has resulted. Charring is defined as a blackening of the gauze caused by combustion. Discoloration of the gauze caused by smoke is acceptable. Charring or igniting of the tissue paper or gauze from the shorting means is not considered a failure.
- c) The cells shall not have exceeded the upper limit charging voltage by more than 150 mV or, if they have, then the charging system shall be permanently disabled from recharging the battery. To determine if recharging is disabled, the battery shall be discharged by using the battery-operated Lamp tested (in the case of an integral system) or by using a new sample of the battery-operated Lamp (in the case of a detachable battery system) to approximately 50 percent charge, followed by an attempt to recharge the battery normally. There shall be no charging current after 10 min or after 25 percent of the nominal capacity has been delivered, whichever

occurs first.

- d) There shall be no evidence of damage to any cell vent.
- e) Live parts shall not become accessible to the standard test finger (IS 1401 test probe B)

**ANNEX B**  
(Informative) (Clause 5.2, 19)

**INFORMATION FOR LUMINAIRE DESIGN**

**B.1** Lamps marked with the symbol according to Fig. 2 should be protected from direct water contact, e.g. by drips, splashing etc., by the luminaire if rated at IPX1 or higher.

NOTE—The X in the IP number indicates a missing numeral but both of the appropriate numerals are marked on the luminaire.

Any IPX1 or better protection of the lamp contact area can only be achieved in luminaires having lampholder with proper IP rating also for the sealing to the diameter of the lamp end and providing protection to the lamp end components containing the contact areas.

**ANNEX C**  
(Clause 1)

**OVERVIEW OF SYSTEMS COMPOSED OF LED MODULES AND CONTROL GEAR**

**C.1** An overview of systems composed of LED system and control gear is given below:

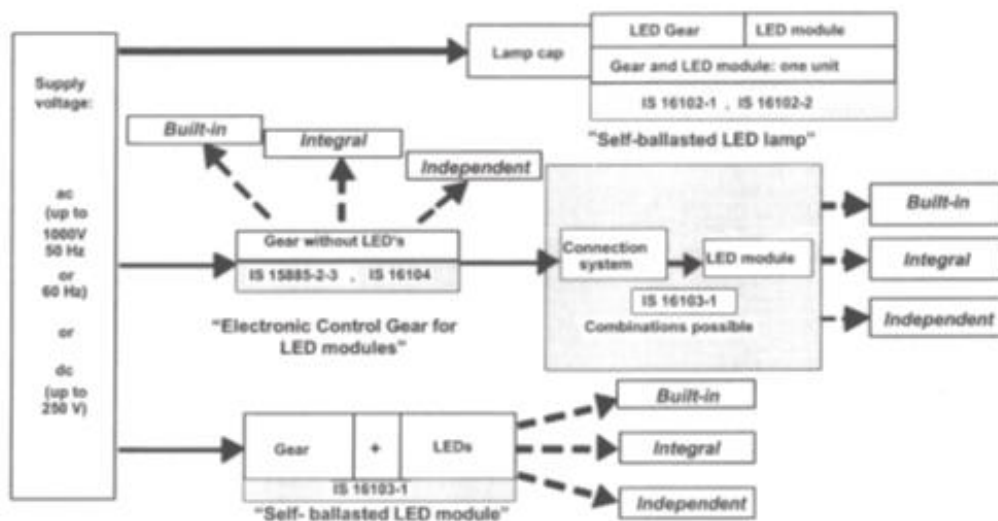

**ANNEX D**

*(Clause 5)*

**LAMPS WITH OPERATING POSITION LIMITATIONS**

**D.1** These symbols are to indicate the only cap down to horizontal operations is permitted of possible overheating.

There shall be text in the vicinity of the symbol in order to avoid it being read upside down.

The symbol for candle and round bulb lamps shown in Figure gives as examples.

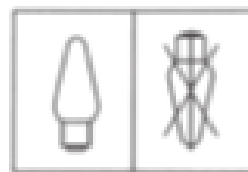

Candle lamps

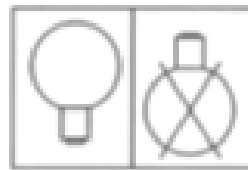

Round bulb lamps

Bulb Lamps

**Fig D.1 Operating and Non-Operating Positions**